

87/88 Series

Masoneilan* Spring Diaphragm Actuators Instruction Manual

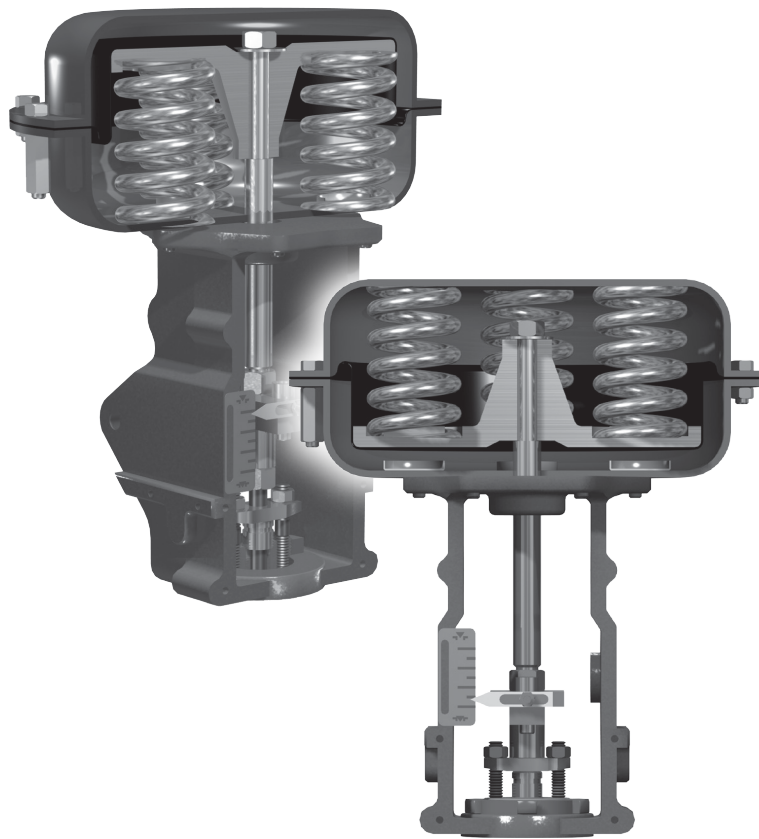

THESE INSTRUCTIONS PROVIDE THE CUSTOMER/OPERATOR WITH IMPORTANT PROJECT-SPECIFIC REFERENCE INFORMATION IN ADDITION TO THE CUSTOMER/OPERATOR'S NORMAL OPERATION AND MAINTENANCE PROCEDURES. SINCE OPERATION AND MAINTENANCE PHILOSOPHIES VARY, GE (GENERAL ELECTRIC COMPANY AND ITS SUBSIDIARIES AND AFFILIATES) DOES NOT ATTEMPT TO DICTATE SPECIFIC PROCEDURES, BUT TO PROVIDE BASIC LIMITATIONS AND REQUIREMENTS CREATED BY THE TYPE OF EQUIPMENT PROVIDED.

THESE INSTRUCTIONS ASSUME THAT OPERATORS ALREADY HAVE A GENERAL UNDERSTANDING OF THE REQUIREMENTS FOR SAFE OPERATION OF MECHANICAL AND ELECTRICAL EQUIPMENT IN POTENTIALLY HAZARDOUS ENVIRONMENTS. THEREFORE, THESE INSTRUCTIONS SHOULD BE INTERPRETED AND APPLIED IN CONJUNCTION WITH THE SAFETY RULES AND REGULATIONS APPLICABLE AT THE SITE AND THE PARTICULAR REQUIREMENTS FOR OPERATION OF OTHER EQUIPMENT AT THE SITE.

THESE INSTRUCTIONS DO NOT PURPORT TO COVER ALL DETAILS OR VARIATIONS IN EQUIPMENT NOR TO PROVIDE FOR EVERY POSSIBLE CONTINGENCY TO BE MET IN CONNECTION WITH INSTALLATION, OPERATION OR MAINTENANCE. SHOULD FURTHER INFORMATION BE DESIRED OR SHOULD PARTICULAR PROBLEMS ARISE WHICH ARE NOT COVERED SUFFICIENTLY FOR THE CUSTOMER/OPERATOR'S PURPOSES THE MATTER SHOULD BE REFERRED TO GE.

THE RIGHTS, OBLIGATIONS AND LIABILITIES OF GE AND THE CUSTOMER/OPERATOR ARE STRICTLY LIMITED TO THOSE EXPRESSLY PROVIDED IN THE CONTRACT RELATING TO THE SUPPLY OF THE EQUIPMENT. NO ADDITIONAL REPRESENTATIONS OR WARRANTIES BY GE REGARDING THE EQUIPMENT OR ITS USE ARE GIVEN OR IMPLIED BY THE ISSUE OF THESE INSTRUCTIONS.

THESE INSTRUCTIONS ARE FURNISHED TO THE CUSTOMER/OPERATOR SOLELY TO ASSIST IN THE INSTALLATION, TESTING, OPERATION, AND/OR MAINTENANCE OF THE EQUIPMENT DESCRIBED. THIS DOCUMENT SHALL NOT BE REPRODUCED IN WHOLE OR IN PART TO ANY THIRD PARTY WITHOUT THE WRITTEN APPROVAL OF GE.

Contents

- 1. Introduction.....2**
- 2. General Numbering System.....2**
- 3. Actuator Description.....2**
- 4. Unpacking.....2**
- 5. Air Piping.....2**
- 6. Actuator Removal.....2**
 - 6.1 Air to close (Model 87), size 3 (Figure 9), and size 6 (Figure 2), with or without handwheel..... 3
 - 6.2 Air to open (Model 88), size 3 and size 6, with handwheel..... 3
 - 6.3 Air to open (Model 88), size 3 (Figure 10) and size 6 (Figure 4) without handwheel..... 3
 - 6.4 Air to close (Model 87), sizes 10, 16, and 23, with and without handwheel..... 4
 - 6.5 Air to open (Model 88), size 10, 16, and 23, with or without handwheel..... 4
- 7. Maintenance.....5**
 - 7.1 Replacing diaphragm air to open actuators (Model 88) with or without handwheel..... 5
 - 7.2 Replacing diaphragm air to close actuator (Model 87), with handwheel..... 6
 - 7.3 Replacing diaphragm air to close actuator (Model 87), size 3 without handwheel..... 7
 - 7.4 Replacing diaphragm air to close actuator (Model 87), size 6, 10, 16 and 23 without handwheel..... 7
 - 7.5 Replace or repack handwheel bearing, size 3 actuators..... 8
 - 7.6 Replace or repack handwheel bearing, size 6 and 10 actuators..... 8
 - 7.7 Replace or repack handwheel bearing size 16 and 23 actuators..... 9
 - 7.8 Replace diaphragm seal and stem seal, air to open actuators (Model 88), size 3..... 9
 - 7.9 Replace diaphragm seal and stem seal, air to open (Model 88) actuators..... 10
- 8. Actuator Range.....11**
 - 8.1 Actuator range change, air to open (Model 88)..... 11
 - 8.2 Actuator range change, air to close (Model 87), size 6,10,16 and 23..... 12
 - 8.3 Actuator range change, air to close (Model 87), size 3..... 15
- 9. Air Action Changes.....16**
 - 9.1 Air to open to air to close (Model 88 to Model 87), size 6,10,16 and 23..... 16
 - 9.2 Air to close to air to open (Model 87 to Model 88), size 6,10,16 and 23 with handwheel..... 17
 - 9.3 Air to close to air to open (Model 87 to Model 88), size 6,10,16 and 23 without handwheel..... 17
 - 9.4 Air to open to air to close (Model 88 to Model 87), size 3..... 18
 - 9.5 Air to close to air to open (Model 87 to Model 88), size 3 with handwheel..... 19
 - 9.6 Air to close to air to open (Model 87 to Model 88), size 3 without handwheel..... 20
- 10. Valve Mounting.....20**
 - 10.1 Air to open (Model 88)..... 21
 - 10.2 Air to close (Model 87)..... 21

Safety Information

Important - Please Read Before Installation

Masoneilan 87/88 Series actuator instructions contain DANGER, WARNING, and CAUTION labels, where necessary, to alert you to safety related or other important information. Read the instructions carefully before installing and maintaining your control valve. DANGER and WARNING hazards are related to personal injury. CAUTION hazards involve equipment or property damage. Operation of damaged equipment can, under certain operational conditions, result in degraded process system performance that can lead to injury or death. Total compliance with all DANGER, WARNING, and CAUTION notices is required for safe operation.



This is the safety alert symbol. It alerts you to potential personal injury hazards. Obey all safety messages that follow this symbol to avoid possible injury or death.



Indicates a potentially hazardous situation which, if not avoided, could result in death or serious injury.



Indicates a potentially hazardous situation which, if not avoided, could result in serious injury.



Indicates a potentially hazardous situation which, if not avoided, could result in minor or moderate injury.



When used without the safety alert symbol indicates a potentially hazardous situation which, if not avoided, could result in property damage.

Note: Indicates important facts and conditions.

About this Manual

- The information in this manual is subject to change without prior notice.
- The information contained in this manual, in whole or part, shall not be transcribed or copied without GE's written permission.
- Please report any errors or questions about the information in this manual to your local supplier.
- These instructions are written specifically for the 87-88 Series actuators, and do not apply for other actuators outside of this product line.

Life Period

The current estimated useful life period for the Masoneilan 87-88 Series Actuator is 25+ years. To enhance the useful life of the product it is essential to conduct annual inspections, routine maintenance and ensure proper installation to avoid any unintended stresses on the product. The specific operating conditions will also impact the useful life of the product. Consult the factory for guidance on specific applications if required prior to installation.

Warranty

Items sold by General Electric are warranted to be free from defects in materials and workmanship for a period of one year from the date of shipment provided said items are used according to GE recommended usages. GE reserves the right to discontinue manufacture of any product or change product materials, design or specifications without notice.

This instruction manual applies to the Masoneilan 87/88 Series actuator.

The Control Valve MUST BE:

- Installed, put into service and maintained by qualified and competent professionals who have undergone suitable training.
- Under certain operating conditions, the use of damaged equipment could cause a degradation of the performance of the system which may lead to personal injury or death.
- Changes to specifications, structure, and components used may not lead to the revision of this manual unless such changes affect the function and performance of the product.
- All surrounding pipe lines must be thoroughly flushed to ensure all entrained debris has been removed from the system.

1. Introduction

The following instructions are designed to assist maintenance personnel in performing most of the maintenance required on the Model 87/88 actuator. GE has highly skilled service engineers available for start-up, maintenance and repair of our actuators and component parts. In addition, a regularly scheduled training program is conducted at the Training Center to train customer service and instrumentation personnel in the operation, maintenance and application of our control valves and instruments. Arrangements for these services can be made through your GE Representative or Sales Office. When performing maintenance, use only replacement parts. Parts are obtainable through your local GE Representative or Sales Office. When ordering parts, always include Model and Serial Number of the unit being repaired.

2. General

These installation and maintenance instructions apply to the Masoneilan Model 87/88 actuator regardless of the valve body on which it is used. Actuator part numbers and recommended spare parts required for maintenance are listed in the Part Reference Table on page 21 and 22. The model number and action of the actuator are shown as part of the model number listed on the identification tag located on the actuator.

Numbering System

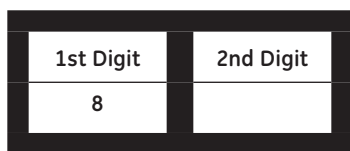

Actuator Type		
87	Air to Close	(Extend Stem)
88	Air to Open	(Retract Stem)

3. Actuator Description

The 87/88 Series is a pneumatic spring diaphragm actuator. The multiple spring design configuration provides four standard spring ranges are achieved by varying spring quantity and placement. A molded rolling diaphragm and deep cases reduce area change, resulting resulting in a linear relationship between travel and air pressure.

CAUTION

For full automatic operation, the handwheel must be placed in the neutral position. Travel will be limited if the handwheel is not in the neutral position.

4. Unpacking

Care must be exercised when unpacking the equipment to prevent damage to the accessories and component parts. Should any problems arise, contact your GE Masoneilan Representative or District Office.

5. Air Piping

The Model 87/88 actuator is designed to accept 1/4" NPT air supply connections. Accessories supplied with the actuator are mounted and connected at the factory.

CAUTION

Do not exceed pressure indicated on identification tag.

6. Actuator Removal

Maintenance on the valve body normally requires removal of the valve actuator. The steps in removal of the actuator are different depending on whether the actuator is air to close or air to open.

Note: Actuator action may be checked by referring to the valve identification tag. Model 87 indicates unit is air to close and Model 88 indicates unit is air to open.

6.1 Air to close (Model 87), size 3 (Figure 9), and size 6 (Figure 2), with or without handwheel

- A. Shut off air supply to actuator and rotate handwheel to the neutral position. [No force exerted on the stem flange.]
- B. Disconnect air piping from diaphragm case.
- C. Check the stem position against the travel scale to ensure that the plug is up (off the seat).
Note: No air pressure is required to the actuator since the spring force acts to open the valve.
- D. Loosen stem lock nuts (1).
- E. Re-tighten lock nuts (1) against each other so they will lock at a point that is not against the stem flange (2).

CAUTION

At this time provisions must be made to support and lift the actuator off the body using recommended lift supports and procedures.

- F. Loosen and remove drive nut.

CAUTION

Depending on stem length, it may be required to raise the actuator off the body slightly to enable the plug stem to disengage from the actuator stem. The actuator must be raised straight off the body to prevent side loading on the plug stem.

- G. Turn the stem lock nut (1), counterclockwise and loosen the plug stem until it disengages from the actuator stem (10).

Note: Do not allow the valve plug to drop or turn against the seat ring, as this could damage the seat and plug.

- H. Remove actuator from the valve body.

CAUTION

Care should be taken in handling the actuator to prevent damage to gauges, tubing, and component parts.

6.2 Air to open (Model 88), size 3 and size 6, with handwheel

CAUTION

The stem flange (2) on these size are not fixed to the actuator stem and are loose parts with the plug stem removed. For safety, the handwheel must be in a free position and the actuator removed from the valve using procedure 6.3 Air to Open without handwheel.

6.3 Air to open (Model 88), size 3 (Figure 10) and size 6 (Figure 4) without handwheel

Since removal of the valve plug stem from the actuator stem connector requires that the valve plug be off the seat, special provisions are necessary to assure that the valve is in the opened position. Proceed as follows for an actuator without a handwheel.

Note: Since air supply piping connected to the actuator is normally rigid, it is required that a manual loading panel with suitable flex tubing be used or some suitable type of flex connections be made between the supply piping and the actuator connection to accommodate movement of the *actuator*.

CAUTION

High stress placed on rigid piping could cause breaking of the air supply line. A flex connector is required.

- A. Shut off air supply to the actuator.
- B. Disconnect air supply piping to the actuator.
- C. Connect manual loading panel tubing to the lower diaphragm case or yoke (size 3) tubing connector.
- D. Apply required air pressure through the manual loading panel to open the valve as is indicated by the stem position relative to the travel scale (9).

CAUTION

Do not exceed pressure indicated on the tag (63) on the diaphragm case.

- E. Loosen stem lock nuts (1).
- F. Re-tighten stem lock nuts (1) against each other so they will lock at a point that is not against the actuator stem flange (2).

CAUTION

At this time provisions must be made to support and lift the actuator off the body using recommended lift supports and procedures.

- G. Loosen and remove drive nut.

CAUTION

Depending on stem length, it may be required to raise the actuator off the body slightly to enable the plug stem to disengage from the actuator stem. The actuator must be raised straight off the body to prevent side loading on the plug stem.

- H. Turn the upper stem lock nut (1) counterclockwise and unscrew the valve plug stem until disengaged from the actuator stem (10).

Note: Do not allow the plug to drop or turn against the seat ring, as this could damage the seat and plug.

- I. Remove actuator from the valve body and shut off air supply pressure.

CAUTION

Care should be taken in handling the actuator to prevent damage to gauges, tubing, and component parts. In addition, since a flex connection is made between the actuator and air piping, care must be taken not to exert pressure on the flex tubing or air piping.

6.4 Air to close (Model 87), sizes 10, 16, and 23, with and without handwheel

(Figure 3)

- A. Shut off air supply to actuator and rotate handwheel to the neutral position.
- B. Disconnect air piping from diaphragm case.
- C. Check the travel indicator (7) against the travel scale (9) to ensure that the plug is up (off the seat).

Note: No air pressure is required to the actuator since the spring pressure tends to open the valve.

- D. Loosen stem lock nut (1).
- E. Remove cap screws (5) from stem connector (2, 4).

Note: Do not allow the valve plug to drop or turn against the seat ring, as this could damage the seat and plug.

CAUTION

At this time provisions must be made to support and lift the actuator off the body using recommended lift supports and procedures.

- F. Loosen and remove drive nut.

CAUTION

Progressively raise actuator off the body to enable the top stem connector (4) to disengage the bottom stem connector (2). The actuator must be raised straight off the body to prevent stress on the plug stem.

- G. Remove bottom stem connector parts (1, 2, 6) from plug stem.
- H. Remove actuator from the valve.

6.5 Air to open (Model 88), size 10, 16, and 23, with or without handwheel

(Figure 5)

Since removal of the valve plug stem from the actuator stem connector requires that the valve plug be off the seat, special provisions are necessary to assure that the valve is in the opened position. Proceed as follows:

Note: Since air supply piping connected to the actuator is normally rigid and the actuator will be moved, it is required that a manual loading panel with suitable flex tubing be used or some suitable type of flex connections be made between the supply piping and the actuator connection.

CAUTION

Unreasonably high stress placed on rigid piping could cause breaking of the air supply line. A flex connector is required.

- A. Shut off air supply to the actuator and rotate handwheel to the neutral position.
- B. Disconnect air supply piping to the actuator.
- C. Connect manual loading panel tubing to the lower diaphragm case tubing connector.

- D. Apply required air pressure through the manual loading panel to open the valve as is indicated by the travel indicator (7) and travel scale (9).

CAUTION

Do not exceed pressure indicated on the tag (63) on the diaphragm case.

- E. Loosen stem lock nuts (1).
- F. Remove cap screws (5) from stem connector (2, 4).

Note: Do not allow the valve plug to drop or turn against the seat ring, as this could damage the seat and plug.

CAUTION

At this time provisions must be made to support and lift the actuator off the body using recommended lift supports and procedures.

- G. Loosen and remove drive nut.

CAUTION

Progressively raise actuator off the body to enable the top stem connector (4) to disengage the bottom stem connector (2). The actuator must be raised straight off the body to prevent stress on the plug stem.

Spring under Load. Before removing the Actuator, ensure that the valve plug is off the seat by pressurizing the diaphragm case. It is now safe to disconnect the valve stem and clamp nut.

- H. Remove bottom stem connector parts (1, 2, 6) from plug stem.
- I. Remove actuator from the valve and shut off air supply pressure.

7. Maintenance

CAUTION

It is recommended that the actuators are placed in an upright position for all disassembly or assembly

CAUTION

Do not use the silicone grease for the silicone rubber of high and low temperature option.

Use fluorine grease of NIPPON KOYU LTD. "LOGENEST LAMBDA" [or equal] as substitute for Dow Corning "Valve Lubricant and Sealant Compound III" [or equal].



Standard "NBR [Black]"



High and low temperature option "Silicone Rubber [Orange]"

7.1 Replacing diaphragm air to open actuators (Model 88) with or without handwheel

(Figure 4, 5 and 10)

- A. Shut off air supply to the actuator, isolate the control valve process pressure to eliminate the valve from moving with spring tension removed.
- B. If valve is equipped with a handwheel, rotate handwheel to a neutral position.
- C. Remove diaphragm case cap screws and nuts (20 and 19). Tension bolts (27 and 28) must be removed last.

Note: Size 3 actuator – remove four diaphragm case cap screws and nuts (27 and 28) leaving the other four tension bolts equally spaced around the case.

CAUTION

Diaphragm case is under spring tension and is equipped with tension bolts which must be removed last.

- D. Remove tension bolts (27 and 28) in multiple steps to relieve spring tension gradually. Remove upper diaphragm case (24).

- E. Note position of springs (21) and spring spacers (18) [if equipped] in the diaphragm plate (26), before you remove these parts.
- F. Remove hex nut (23) [size 3] or jam nut (23) [all other sizes]. Also remove spacer (22) [size 3] and diaphragm washer (22) [all sizes].
- G. Remove diaphragm plate (26) and diaphragm (25).

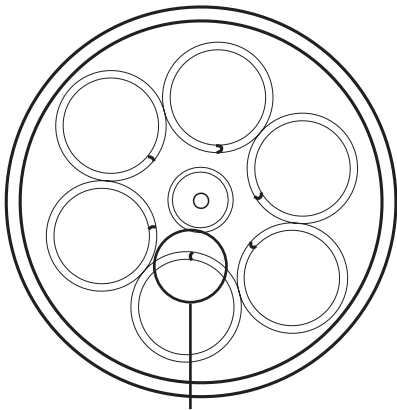

Spring coil ends pointed towards actuator stem

Figure 1

- H. Replace the new diaphragm (25) on the diaphragm plate (26).
- I. Size 3 actuator, coat the threads of hex nut (23) and the surfaces of spacer (22) with Chesterton 725 nickel compound or equivalent. All other sizes, coat the actuator stem threads (10) and the surfaces of washer (22) with Dow Corning Sealant Compound III or equal.
- J. Check placement of spacer (14 and 22), reassemble diaphragm (25), diaphragm plate (26), and washer (22) then tighten fastener (23) in proper locations.
- K. Position springs (21) and spring spacers (18) [if used] in the diaphragm plate.

Note: Arrange springs so that the coil ends are pointed toward the actuator stem as shown in Figure 1. This step assures best actuator performance.
- L. Replace upper diaphragm case (24) and tension bolts.

Note: Tension bolts should be spaced equally around the bolt circle of the case.
- M. Tighten the tension bolts in equal steps until the cases meet. Replace the remaining cap screws and nuts.

CAUTION

Tighten cap screws and nuts evenly. Do not over tighten as this could possibly warp the diaphragm cases. See Table 3 for torque values.

- N. If so equipped, rotate handwheel to the desired position.

7.2 Replacing diaphragm air to close actuator (Model 87), with handwheel

(Figures 2, 3, 8, 9, 11 and 12)

CAUTION

The handwheel assembly can hold spring tension in the actuator when the diaphragm case is removed. To prevent possible injury, remove handwheel per the following procedure.

- A. Shut off air supply to the actuator, isolate the control process pressure to eliminate the valve plug from moving with spring tension removed.
- B. Rotate the handwheel (41) to a neutral position.
- C. For size 3 actuator, remove one of the two retaining rings (46) which are mounted on lever pin (45).

CAUTION

Removing the lever pin (45) will disconnect the handwheel assembly from the actuator. Support the handwheel assembly to avoid possible injury.

For all other sizes, remove two cap screw (93) and washer (94), and remove two handwheel pivot pins (33) which are mounted through the yoke and secure the handwheel pivot (36) in place, (see Figure 8).

- D. For size 3 actuator, remove lever pin (45) and secure the handwheel holder (40) in place (see Figures 11 and 12).

For all other sizes, let the complete handwheel assembly swing down and out of the way of the top stem connector (4) [stem flange (2) on size 6 actuator].

- E. Proceed with the instructions for air to close actuators without handwheel (7.3).

7.3 Replacing diaphragm air to close actuator (Model 87), size 3 without handwheel

(Figures 9, 11 and 12)

- A. Shut off air supply to the actuator and remove air piping from the upper diaphragm case (24).
- B. Check the travel indicator on stem flange (2) against the travel scale (9) to ensure that the plug is up (off the seat).
Note: No air pressure is required to the actuator since the spring pressure tends to open the valve.
- C. Loosen stem lock nuts (1).
- D. Re-tighten lock nuts (1) against each other so they will lock at a point that is not against the stem flange (2).
- E. Turn the stem lock nut (1) counterclockwise and loosen the plug stem until it disengages from the actuator stem (10).
Note: Depending on stem length, it may be required to separate the size 3 actuator off the valve body, as indicated in Section 6.1.
Note: Do not allow the plug to drop or turn against the seat ring, as this could damage the seat and plug.
- F. Remove four diaphragm case cap screws and nuts (27 and 28) leaving the other four installed on the case equally spaced.

CAUTION

Diaphragm case is under spring tension. The remaining four screws and nuts are tension bolts.

- G. Remove tension bolts (four remaining 27 and 28) in multiple steps to relieve spring tension gradually. Remove upper diaphragm case (24).
- H. Remove hex nut (23) and spacer (14).
- I. Replace the new diaphragm (25) on the diaphragm plate (26).
- J. Coat the threads of hex nut (23) and the surfaces of spacer (14) with Chesterton 725 nickel compound or equivalent. Install spacer (14) and tighten hex nut (23) per Table 3.
- K. Replace upper diaphragm case (24) and tension bolts (four cap screws and nuts 27 and 28).

Note: Tension bolts should be spaced equally around the bolt circle of the case.

- L. Tighten the tension bolts (27 and 28) in equal steps until the cases meet. Replace the remaining cap screws (27) and nuts (28).

CAUTION

Tighten cap screws and nuts evenly. Do not over tighten as this could possibly warp the diaphragm cases. See Table 3 for torque values.

- M. Screw the plug stem back into the actuator stem (10) thru the stem flange (2) and recalibrate the seated position of the valve.
Note: If the actuator has been removed from the valve body, reinstall it as indicated in Section 10.2.
Note: If the actuator has a handwheel (Section 7.2), continue with the following steps:
- N. Hold the handwheel holder (40) in position between the yoke legs and slide the lever pin (45) through the hole in the yoke and lever. Be sure that levers (44) are above the stem flange (2).
- O. Secure the lever pin (45) with the second retaining ring (46).

7.4 Replacing diaphragm air to close actuator (Model 87), size 6, 10, 16 and 23 without handwheel

(Figures 2, 3 and 8)

- A. Shut off air supply to the actuator and remove air piping from the upper diaphragm case (24).
- B. Remove the two socket head cap screws (5) which hold the top and bottom stem connector (2 and 4) together.
Note: The size 6 actuator only has a stem flange. For diaphragm replacement, the stem lock nuts (1) must be loosened. The plug stem is turned out at the actuator stem (10) in order to allow the actuator stem to rise with release of spring tension. Depending on stem length, it may be required to separate the size 6 actuator off the valve body, as indicated in Section 6.1.
- C. Remove diaphragm case cap screws and nuts (20 and 19).

CAUTION

Diaphragm case is under spring tension and is equipped with tension bolts (27 and 28) which must be removed last.

- D. Remove tension bolts (27 and 28) in multiple steps to relieve spring tension gradually. Remove upper diaphragm case (24).
- E. Remove jam nut (23) and diaphragm washer (22).
- F. Replace new diaphragm (25) on the diaphragm plate (26).
- G. Coat the actuator stem threads (10) and the surfaces of washer (22) with Dow Corning Sealant Compound III or its equivalent. Install washer (22) and tighten fastener (23).
- H. Replace upper diaphragm case (24) and tension bolts (27 and 28).
Note: Tension bolts should be spaced equally around the bolt circle of the case.
- I. Tighten the tension bolts (27 and 28) in equal steps until the cases meet. Replace the remaining cap screws (20) and nuts (19).

CAUTION

Tighten cap screws and nuts evenly. Do not over tighten as this could possibly warp the diaphragm cases. See Table 3 for torque values.

- J. Position top and bottom stem connectors (2 and 4) and replace the two socket head cap screws (5) and recalibrate the seated position of the valve, (Section 10.2).
Note: Size 6 actuator - Screw the plug stem back into the actuator stem (10) thru the stem flange and recalibrate the seated position of the valve. If the actuator has been removed from the valve body, re-install it as indicated in Section 10.2).
Note: If the actuator has a handwheel (Section 7.2), continue with the following steps:
- K. Swing handwheel assembly back up into place.
- L. Install the two pivot pins (33) in the yoke and engage them into the handwheel pivot (36). And install the two washer (94) and cap screw (93) through the handwheel cover (57).

7.5 Replace or repack handwheel bearing, size 3 actuators

(Figures 11,12 and 13)

- A. Rotate handwheel to a free position.
- B. Remove handwheel cap screw (20) and washer (42).
- C. Remove handwheel (41) and key (47).
- D. Remove one of the two retaining rings (46) which are mounted on lever pin (45).

CAUTION

Removing the lever pin (45) will disconnect the handwheel assembly from the actuator. Support the handwheel assembly to avoid possible injury.

- E. Remove lever pin (45) and secure the handwheel holder (40) in place.
- F. Remove the complete handwheel assembly from the actuator.
- G. Remove both cover cap screw (20) and handwheel cover (57).
- H. Remove retaining ring (35), handwheel pivot (36) and bushing (37) to release the bearing.
- I. Remove single row ball and shaft ring bearing (34) from handwheel stem (39) and bearing ball housing ring from the handwheel pivot (36).
- J. Replace or clean to repack bearing (34) with new grease.
- K. Bearing should be packed with Mobilux No. 2 grease or equivalent.
Note: It is important that bearing is packed with grease, and not just coated.
- L. To reassemble, reverse removal procedures from step (I) through (B).

7.6 Replace or repack handwheel bearing, size 6 and 10 actuators

(Figure 6)

- A. Rotate handwheel to a free position.
- B. Remove handwheel cap screw (20) and washer (42).
- C. Remove handwheel (41) and lock nut (43).

- D. Remove lock pin (91), cap screw (93), and washer (94) to release handwheel cover (57). Remove cover.
- E. Remove pivot pins (33) from the yoke which hold the handwheel pivot (36).
- F. Remove snap rings (46) and remove lever pin (45) to release handwheel assembly.
- G. Turn handwheel stem (39) until it clears traveling nut (40).
- H. Remove snap ring (38) and bearing ring (37) to release the handwheel stem (39) from the bearing.
- I. Remove snap ring (35) to release bearing (34).
- J. Replace or clean to repack bearing (34) with new grease.
- K. Bearing should be packed with Mobilux No. 2 grease or equal.
Note: It is important that bearing is packed with grease, and not just coated.
- L. To reassemble, reverse removal procedures from step (I) through (B).

7.7 Replace or repack handwheel bearing size 16 and 23 actuators

(Figures 7 & 8)

- A. Rotate handwheel to a free position.
- B. Remove lock pin (91), cap screw (93), and washer (94) to release handwheel cover (57).
- C. Remove pivot pins (33) which engage the handwheel pivot (36) thru the yoke.
- D. Remove snap rings (46) and remove lever pin (45) to release complete handwheel assembly.
- E. Remove cap screw (97) and end flange (96) to release the handwheel stem (39) from the bearing.
- F. Remove snap ring (35) to release bearing (34).
- G. Replace or clean to repack the bearing with new grease.
- H. Pack bearing (34) with Mobilux No. 2 grease or equal.
Note: It is important that bearing is packed with grease, and not just coated.
- I. For remounting, reverse removal procedures from step (F) through (B).

7.8 Replace diaphragm seal and stem seal, air to open actuators (Model 88), size 3

(Figure 10)

- A. Shut off air supply to the actuator, isolate the control valve process pressure to eliminate the valve from moving with spring tension removed.
- B. If valve is equipped with a handwheel, rotate handwheel to a free position.
- C. Remove four diaphragm case cap screws and nuts (27 and 28) leaving the other four installed on the case equally spaced

CAUTION

Diaphragm case is under spring tension. The remaining four screws and nuts are tension bolts.

- D. Remove tension bolts (four remaining 27 and 28) in multiple steps to relieve spring tension gradually. Remove upper diaphragm case (24).
- E. Note position of springs (21) and spring spacers (18) [if equipped] in the diaphragm plate (26), before you remove these parts.
- F. Remove springs (21) and spring spacers (18) if used.
- G. Loosen lock nuts (1). Re-tighten lock nuts against each other so they will lock at a point that is not against the stem flange (2). By means of a wrench, hold the nuts (1) and plug stem. Turn the actuator stem (10) subassembly until it disengages from the plug stem and remove completely from actuator.
- H. Remove case cap screws (16) and spring guide (29).
- I. Remove lower diaphragm case (17) to gain access to O-ring (13).
Note: Mark orientation of the case to the yoke.
Note: If diaphragm case O-ring (13) replacement is the only maintenance, proceed to Step N.
- J. Remove stem wiper (11) and O-rings (12).
- K. Clean stem wiper and O-ring grooves of the yoke (31).
- L. Apply a generous coating of Dow Corning Compound III (or equivalent) to a new O-ring (12) and insert it into the yoke (31).
- M. Insert a new stem wiper (11) into the lower groove of the yoke (31).

- N. Clean cap screws (16) and their threaded holes on the yoke (31).
- O. Coat a new O-ring and the stem bushing (30) and O-ring (12) in the yoke with Dow Corning Compound III (or equivalent).
- P. Insert a new O-ring (12) in the yoke groove.
- Q. Place the diaphragm case (17) on the yoke.
- R. Apply Never-Seez (anti-seize compound or equivalent) to cap screw threads (16).
- S. Assemble spring guides (29) and cap screws (16).
- T. Re-install the actuator stem (10) sub-assembly into the yoke bushing. Turn actuator stem on the plug stem after installing the stem flange (2). Turn until stem spacer (14) contacts the lower diaphragm case (17).
- U. Lock the stem flange (2) and the two lock nuts (1) against the lower part of actuator stem.
- V. Position springs (21) and spring spacers (18) [if used] in the diaphragm plate.

Note: Arrange springs so that the coil ends are pointed toward the actuator stem as shown in Figure 1. This step assures best actuator performance.

- W. Replace upper diaphragm case (24) and the tension bolts (four cap screws 27 and 28).
- Note:** Tension bolts should be spaced equally around the bolt circle of the case.
- X. Tighten the tension bolts (27 and 28) in equal steps until the cases meet. Replace the remaining cap screws (27) and nuts (28).

CAUTION

Tighten cap screws and nuts evenly. Do not over tighten as this could possibly warp the diaphragm cases. See Table 3 for torque values.

- Y. If necessary, recalibrate the seated position of the valve (Section 10.1).

7.9 Replace diaphragm seal and stem seal, air to open (Model 88) actuators

(Figure 4 and 5)

- A. Shut off air supply to the actuator, isolate the control valve process pressure to eliminate the valve from moving with spring tension removed.

- B. If valve is equipped with a handwheel, rotate handwheel to a free position.
- C. Remove diaphragm case cap screws and nuts (20 and 19).

CAUTION

Diaphragm case is under spring tension and is equipped with tension bolts (27 and 28) which must be removed last.

- D. Remove tension bolts (27 and 28) in multiple steps to relieve spring tension gradually. Remove upper diaphragm case (24).
- E. Note position of springs (21) and spring spacers (18) [if equipped] in the diaphragm plate (26).
- F. Remove springs (21) and spring spacers (18) if used.

On size 6 actuator:

- G. Loosen lock nuts (1). Re-tighten lock nuts against each other so they will lock at a point that is not against the stem flange (2). By means of a wrench, hold the lock nuts (1) and plug stem. Turn the actuator stem (10) subassembly until it disengages from the plug stem and remove completely from actuator.

On size 10,16 and 23 actuators:

- G. Loosen lock nut (32) on actuator stem (10). Hold the connector device (2, 4, 6). Turn the actuator stem(10) sub-assembly and remove it when it clears the connector insert (6), (on size 10), or the top stem connector (4), (on sizes 16 & 23).

On size 6,10,16 and 23

- H. Remove case cap screws (16) to gain access to seal washers (15).

Note: If seal washers (15) replacement is the only maintenance, proceed to Step M.

- I. Remove lower diaphragm case (17).
- Note:** Mark orientation of the case to the yoke.
- J. Replace stem wiper (11) and O-rings (12 and 13).
- K. Coat O-rings (12 and 13) and inside of yoke O-ring groove (31) with Dow Corning Compound III (or equivalent).
- L. Place the diaphragm case (17) on the yoke.
- M. Coat the surface of the spring guides (29) in contact with the diaphragm case with Dow Corning Sealant

Compound III or equivalent. Assemble spring guides (29), new seal washers (15), and cap screws (16) in this order.

- N. Re-install the actuator stem (10) sub-assembly into the yoke bushing. Turn actuator stem into insert (6), (size 10), or into the top stem connector (4), (size 16 & 23). In case of size 6 actuator, turn actuator stem on the plug stem after installing the stem connector(2). Turn until stem spacer (14) contacts the lower diaphragm case (17).
- O. Tighten lock nut (32) against connector insert (6), (size 10), or against the top stem connector (4), (on sizes 16 & 23). In case of size 6 actuator, lock the stem flange (2) and the two lock nuts (1) against the lower part of actuator stem.
- P. Position springs (21) and spring spacers (18) [if used] in the diaphragm plate.
Note: Arrange springs so that the coil ends are pointed toward the actuator stem as shown in Figure 1. This step assures best actuator performance.
- Q. Replace upper diaphragm case (24) and the tension bolts (27 and 28).
Note: Tension bolts should be spaced equally around the bolt circle of the case.
- R. Tighten the tension bolts (27 and 28) in equal steps until the cases meet. Replace the remaining cap screws (20) and nuts (19).

CAUTION

Tighten cap screws and nuts evenly. Do not over tighten as this could possibly warp the diaphragm cases. See Table 3 for torque values.

- S. If necessary, recalibrate the seated position of the valve (Section 10.1).

8. Actuator Range

CAUTION

Do not use the silicone grease for the silicone rubber of high and low temperature option.

Use fluorine grease of NIPPON KOYU LTD. "LOGENEST LAMBDA" [or equal] as substitute for Dow Corning "Valve Lubricant and Sealant Compound III" [or equal].



Standard "NBR [Black]"



High and low temperature option
"Silicone Rubber [Orange]"

8.1 Actuator range change, air to open (Model 88).

- A. Shut off air supply to the actuator, isolate the control valve process pressure to eliminate the valve from moving with spring tension removed.
- B. If valve is equipped with a handwheel, rotate handwheel to a free position.
- C. Remove diaphragm case cap screws and nuts (20 and 19). Tension bolts (27 and 28) must be removed last.

Note: Size 3 actuator – Remove four diaphragm case cap screw and nuts (27 and 28) leaving the other four tension bolts equally spaced around the case.

CAUTION

Diaphragm case is under spring tension and is equipped with tension bolts which must be removed last.

- D. Remove tension bolts (27 and 28) in multiple steps to relieve spring tension gradually. Remove upper diaphragm case (24).
- E. Position springs (21) [and spring spacers (18) if new range use them] in the diaphragm plate.
- F. Refer to Tables 1, 2 and 4 for spring information:
 - a. For 11 and 21 psi (0,759 and 1,448bar) initials, the springs are placed directly on the upper pedestals in the diaphragm plate (26).

Size 3 actuator - For 11 and 21 psi (0,759 and 1,448bar) initials, the springs are installed with spring spacers (18). The spring spacers (18) are placed as shown in the cross sectional view, Figure 10.

- b. For 3 and 6 psi (0,207 and 0,414bar) initials, the springs are placed in the bottom cavity in the diaphragm plate.
Size 3 actuator - For 3 and 6 psi (0,207 and 0,414bar) initials, the springs are installed without spring spacers.
- c. For 11 and 21 psi (0,759 and 1,448bar) initials and travel ranges larger than 0.8" (20mm), the spring spacers (18) are placed as shown in the cross sectional view, Figure 5.

Note: Spring spacers (18) are not required for the No.6 actuator.

Note: Arrange springs so that the coil ends are pointed toward the actuator stem as shown in Figure 1. This step assures best actuator performance.

- G. Replace upper diaphragm case (24) and tension bolts (27, and 28).

Note: Tension bolts should be spaced equally around the bolt circle of the case.

- H. Tighten the tension bolts (27 and 28) in equal steps until the cases meet. Replace the remaining cap screws (20) and nuts (19) [Screw (27) and nuts (28) for size 3].

CAUTION

Tighten cap screws and nuts evenly. Do not over tighten as this could possibly warp the diaphragm cases. See Table 3 for torque values.

- I. If so equipped, rotate handwheel to the desired position.

8.2 Actuator range change, air to close (Model 87), size 6,10,16 and 23

Note: If actuator is equipped with a handwheel, please follow steps 7.2 A, B, C and D to disengage this assembly.

- A. Shut off air supply to the actuator and remove air piping from the upper diaphragm case (24).
- B. Remove the two socket head cap screws (5) which hold the top and bottom stem connector (2 and 4) together.

Note: The size 6 actuator only has a stem flange (2). For access to springs, the stem lock nuts (1) must be loosened. **The plug stem is turned out at the actuator stem (10)** to allow the actuator stem to rise with release of spring tension. Depending on

stem length, it may be required to separate the size 6 actuator off the valve body, as indicated in Section 6.1.

- C. Remove diaphragm case cap screws and nuts (20 and 19).

CAUTION

Diaphragm case is under spring tension and is equipped with tension bolts (27 and 28) which must be removed last.

- D. Remove tension bolts (27 and 28) and compression nuts (28) in multiple steps to relieve spring tension gradually. Remove upper diaphragm case (24).
- E. Remove jam nut (23) and diaphragm washer (22).
- F. Remove diaphragm plate (26) and diaphragm (25).
- G. Place springs (21) over the spring guides (29).
- H. Refer to Tables 1, 2 and 4 for spring information:
 - a. For 11 and 21 psi (0,759 and 1,448bar) initials, the springs are placed directly on the upper pedestals in the diaphragm plate (26).
 - b. For 3 and 6 psi (0,207 and 0,414bar) initials, the springs are placed in the bottom cavity in the diaphragm plate.
 - c. For 11 and 21 psi (0,759 and 1,448bar) initials and travel ranges larger than 0.8" (20mm), the spring spacers (18) are placed as shown in the cross sectional view, Figure 5.

Note: Spring spacers (18) are not required for 0.8" (20mm) travel ranges.

Note: Arrange springs so that the coil ends are pointed toward the actuator stem as shown in Figure 1. This step assures best actuator performance.

- I. Replace the diaphragm plate (26) on the actuator stem (10) and over the springs. To ensure the springs are properly located, check the view hole in the diaphragm plate. A spring should be visible.
- J. Install the diaphragm (25).
- K. Coat the actuator stem threads (10) and the surfaces of washer (22) with Dow Corning Sealant Compound III or equivalent.
- L. Replace upper diaphragm case (24) and the tension bolts (27 and 28).

Note: Tension bolts should be spaced equally around the bolt circle of the case.

- M. Tighten the tension bolts (27 and 28) in equal steps until the cases meet. Replace the remaining cap screws (20) and nuts (19).

CAUTION

Tighten cap screws and nuts evenly. Do not over tighten as this could possibly warp the diaphragm cases. See Table 3 for torque values.

- N. Position top and bottom stem connectors (2 and 4) and replace the two socket head cap screws (5) and

recalibrate the seated position of the valve (Section 10.2).

Note: Size 6 actuator-Screw the plug stem back into the actuator stem (10) thru the stem flange (2) and recalibrate the seated position of the valve. If the actuator has been removed from the valve body, re-install it as indicated in Section 10.2).

Note: If the actuator has a handwheel (Section 7.2), continue with the following steps:

Table 1

Actuator Travel in. (mm)	Spring Color
0.8 (20)	Red
1.5 (38)	Blue
2.0 (51)	Green
2.5 (64)	Yellow

Table 2

Spring Range psi (bar)	No. of Springs Required	Spring Spacer (18) Required
3-15 (0.207-1.034)	3	No
6-30 (0.414-2.069)	6	No
11-23 (0.759-1.586)	3	Yes ⁽¹⁾
21-45 (1.448-3.103)	6	Yes ⁽¹⁾

⁽¹⁾A spring spacer (18) is required on Size 10 for 1.5 in. (38mm) travel only, and on Size 16 and 23, for 1.5 in. (38mm), 2.0 in. (51mm) and 2.5 in. (64mm) travels.

Table 3 – Actuator Assembly Torques

Ref. No.	Description	Actuator Size									
		3		6		10		16		23	
		ft-lbs	N-m	ft-lbs	N-m	ft-lbs	N-m	ft-lbs	N-m	ft-lbs	N-m
1	Hex Nut .500 - 20 UNF	25	34	25	34	25	34	25	34	25	34
	Hex Nut .625 - 18 UNF					55	74	55	74	55	74
	Hex Nut .750 - 16 UNF					95	129	95	129	95	129
	Hex Nut 1.00 - 14 UNS							150	203	150	203
5	Connector Cap Screw			35 ⁽¹⁾	47 ⁽¹⁾	35	47	125	169	125	169
16	Yoke Cap Screw	22	30	37	50	37	50	59	80	59	80
19,20,27,28	Case Bolting or Tension Bolting	22	30	21	28	25	34	30	40	31	42
23	Jam Nut, Hex Nut	48	65	37	50	66	90	95	129	150	203
32	Stem Lock Nut					55	74	95	129	150	203
33	Pivot Pin			60	81	60	81	80	108	80	108
20	Handwheel Cap Screw	53 ⁽²⁾	6	25	34	25	34	66	90	66	90
97	Handwheel Stem Cap Screw							300	407	300	407

⁽¹⁾ Torque shown is for size 6 actuator with Bellows Seal design requiring Stem Connector Option.

⁽²⁾ Torque value in units of in-lbs.

Listed values are nominal torques. Tolerance is +/- 10%.

Actuator No.	Travel & Color Code	Range (psi)	Qty.	Springs Position
3	0.8" (20mm) Red	3-15	3	A
		6-30	6	B
		11-23	3	E
		21-45	6	F
6	0.8" (20mm) Red	3-15	3	A
		6-30	6	B
		11-23	3	C
		21-45	6	D
10	0.8" (20mm) Red	3-15	3	A
		6-30	6	B
		11-23	3	C
	1.5" (38mm) Blue	3-15	3	A
		6-30	6	B
		11-23	3	E
16	0.8" (20mm) Red	3-15	3	A
		6-30	6	B
		11-23	3	C
		21-45	6	D
	1.5" (38mm) Blue	3-15	3	A
		6-30	6	B
		11-23	3	E
		21-45	6	F
	2.0" (51mm) Green	3-15	3	A
		6-30	6	B
		11-23	3	E
		21-45	6	F
2.5" (64mm) Yellow	3-15	3	A	
	6-30	6	B	
	11-23	3	E	
	21-45	6	F	
23	0.8" (20mm) Red	3-15	3	A
		6-30	6	B
		11-23	3	C
		21-45	6	D
	1.5" (38mm) Blue	3-15	3	A
		6-30	6	B
		11-23	3	E
		21-45	6	F
	2.0" (51mm) Green	3-15	3	A
		6-30	6	B
		11-23	3	E
		21-45	6	F
2.5" (64mm) Yellow	3-15	3	A	
	6-30	6	B	
	11-23	3	E	
	21-45	6	F	

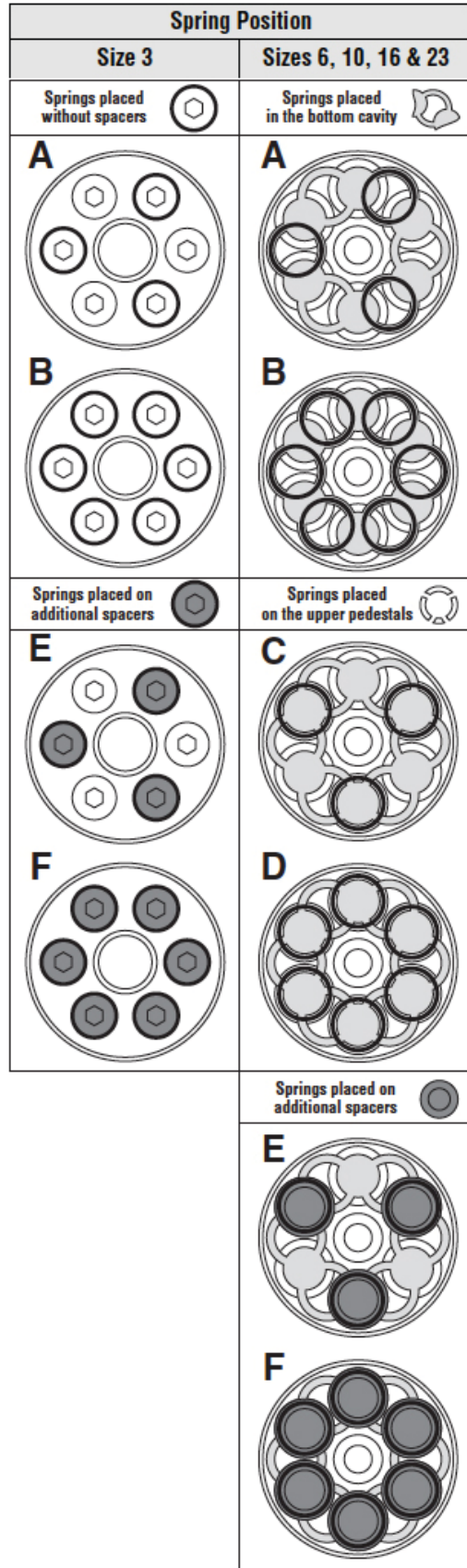

Table 4
Diaphragm plate spring arrangement

8.3 Actuator range change, air to close (Model 87), size 3

Note: If actuator is equipped with a handwheel, please follow steps 7.2 A, B, C and D to disengage this assembly.

- A. Shut off air supply to the actuator and remove air piping from the upper diaphragm case (24).
- B. Check the travel indicator on stem flange (2) against the travel scale (9) to ensure that the plug is up (off the seat).
Note: No air pressure is required to the actuator since the spring pressure tends to open the valve.
- C. Loosen stem lock nuts (1).
- D. Re-tighten lock nuts (1) against each other so they will lock at a point that is not against the stem flange (2).
- E. Turn the stem lock nut (1) counterclockwise and loosen the plug stem until it disengages from the actuator stem (10).

Note: Depending on stem length, it may be required to separate the size 3 actuator off the valve body, as indicated in Section 6.1.

Note: Do not allow the plug to drop or turn against the seat ring, as this could damage the seat and plug.

- F. Remove four diaphragm case cap screws and nuts (27 and 28) leaving the other four installed on the case equally spaced.

CAUTION

Diaphragm case is under spring tension. The remaining four screws and nuts are tension bolts.

- G. Remove tension bolts (four remaining 27 and 28) in multiple steps to relieve spring tension gradually. Remove upper diaphragm case (24).
- H. Remove hex nut (23) and spacer (14).
- I. Remove diaphragm (25) and diaphragm plate (26).
- J. Place springs (21) over the spring guides (29).
- K. Refer to Tables 1, 2 and 4 for spring information:
 - a. For 11 and 21 psi (0,759 and 1,448bar) initials, the springs are installed with spring spacers (18). The spring spacers (18) are placed as shown in the cross sectional view, Figure 9.

- b. For 3 and 6 psi (0,207 and 0,414bar) initials, the springs are installed without spring spacers.

Note: Arrange springs so that the coil ends are pointed toward the actuator stem as shown in Figure 1. This step assures best actuator performance.

- L. Replace the diaphragm plate (26) on the actuator stem (10) and over the springs.
- M. Install the diaphragm (25).
- N. Coat the threads of hex nut (23) and the surfaces of spacer (14) with Chesterton 725 nickel compound or equivalent. Install spacer (14) and tighten hex nut (23) per Table 3.
- O. Replace upper diaphragm case (24) and tension bolts (four cap screws and nuts 27 and 28).
Note: Tension bolts should be spaced equally around the bolt circle of the case.
- P. Tighten the tension bolts (27 and 28) per Table 3 in equal steps until the cases meet. Replace the remaining cap screws (27) and nuts (28) and tighten per Table 3.

CAUTION

Tighten cap screws and nuts evenly. Do not over tighten as this could possibly warp the diaphragm cases. See Table 3 for torque values.

- Q. Screw the plug stem back into the actuator stem (10) thru the stem flange and recalibrate the seated position of the valve.
Note: If the actuator has been removed from the valve body, reinstall it as indicated in Section 10.2.
Note: If the actuator has a handwheel (Section 7.2), continue with the following steps:
- R. Hold the handwheel holder (40) in position between the yoke legs and slide the lever pin (45) through the hole in the yoke and lever. Be sure that levers (44) are above the stem flange (2).
- S. Secure the lever pin (45) with the second retaining ring (46).

9. Air Action Changes

CAUTION

Do not use the silicone grease for the silicone rubber of high and low temperature option.

Use fluorine grease of NIPPON KOYU LTD. "LOGENEST LAMBDA" [or equal] as substitute for Dow Corning "Valve Lubricant and Sealant Compound III" [or equal].



Standard "NBR [Black]"



High and low temperature option
"Silicone Rubber [Orange]"

9.1 Air to open to air to close (Model 88 to Model 87), size 6,10,16 and 23

- Shut off air supply to the actuator, isolate the control valve process pressure to eliminate the valve from moving with spring tension removed.
- If valve is equipped with a handwheel, rotate handwheel to a neutral position.
- Remove snap rings (46) and remove lever pin (45) to allow handwheel assembly to swing away from the stem connector (2-4).
- Remove the two socket head cap screws (5) which hold the top and bottom stem connector (2 and 4) together.

Note: The size 6 actuator only has a stem flange (2). For changing of action, the stem lock nuts (1) must be loosened. The plug stem is turned out at the actuator stem (10) in order to allow the actuator stem to rise with springs installed in Model 87. Depending on stem length, it may be required to separate the size 6 actuator off the valve body, as indicated in Section 6.3.

- Remove diaphragm case cap screws and nuts (20 and 19) and vent cap (59).

CAUTION

Diaphragm case is under spring tension and is equipped with tension bolts (27 and 28) which must be removed last.

- Remove tension bolts (27 and 28) in multiple steps to relieve spring tension gradually. Remove upper diaphragm case (24). Remove springs (21) and spacer (18) [if equipped].
- Remove jam nut (23) and diaphragm washer (22) and travel stop (71) [if equipped].
- Remove diaphragm plate (26) and diaphragm (25).
- Place springs (21) over the spring guides (29).
- Refer to Tables 1, 2 and 4 for spring information. Refer also to Section 8.2 H

Note: Spring spacers (18) are not required for 0.8" (20mm) travel ranges

Note: Arrange springs so that the coil ends are pointed toward the actuator as shown in Figure 1. This step assures best actuator performance.

- Invert and replace the diaphragm plate (26) on the actuator stem (10) and over the springs.
Note: To ensure the springs are properly located, check the view hole in the diaphragm plate. A spring should be visible.
- Install the diaphragm (25).
- Coat the actuator stem threads (10) and the surfaces of washer (22) with Dow Corning Sealant Compound III or equivalent. Then place and tighten the jam nut (23).
- Replace upper diaphragm case (24) and tension bolts (27 and 28).
Note: Tension bolts should be spaced equally around the bolt circle of the case.
- Tighten the tension bolts (27 and 28) in equal steps until the cases meet. Replace the remaining cap screws (20) and nuts (19).

CAUTION

Tighten cap screws and nuts evenly. Do not over tighten as this could possibly warp the diaphragm cases. See Table 3 for torque values.

- P. Position top and bottom stem connectors (2 and 4) and replace the two socket head cap screws (5) and recalibrate the seated position of the valve (Section 10.2).

Note Size 6 actuator – Screw the plug stem back into the actuator stem (10) thru the stem flange (2) and recalibrate the seated position of the valve. If the actuator has been removed from the valve body, reinstall it as indicated in Section 10.2.

Note: If the actuator has a handwheel, continue with the following steps:

- Q. Swing handwheel assembly back up into place. The handwheel (41) may have to be turned in order to position the lower pivot pins (33).
- R. With the pivot pins positioned on top of the stem connector (2 and 4), replace the lever pin (45) and snap rings (46).

9.2 Air to close to air to open (Model 87 to Model 88), size 6,10,16 and 23 with handwheel

CAUTION

The handwheel assembly can hold spring tension in the actuator when the diaphragm case is removed. To prevent possible injury, remove handwheel per the following procedure.

- A. Shut off air supply to the actuator, isolate the control valve process pressure to eliminate the valve from moving with spring tension removed.
- B. Rotate the handwheel (41) to a neutral position.
- C. Remove snap rings (46) and lever pins (45).
- D. The complete handwheel assembly can now swing out of the way of the top stem connector (2 and 4) [stem flange (2) on the size 6 actuator].
- E. Proceed with the instructions for actuators without handwheel (9.3 Step B).

9.3 Air to close to air to open (Model 87 to Model 88), size 6,10,16 and 23 without handwheel

- A. Shut off air supply to the actuator and remove air piping from the upper diaphragm case (24).
- B. Remove the two socket head cap screws (5) which hold the top and bottom stem connector (2 and 4) together.

Note: The size 6 actuator only has a stem flange (2). For changing of action, the stem lock nuts (1) must be loosened. The plug stem is disconnected from the actuator stem (10) in order to allow the actuator stem to rise with release of spring tension during disassembly.

Depending on stem length, it may be required to separate the size 6 actuator off the valve body, as indicated in Section 6.1.

- C. Remove diaphragm case cap screws and nuts (20 and 19).

CAUTION

Diaphragm case is under spring tension and is equipped with tension bolts (27 and 28) which must be removed last.

- D. Remove tension bolts (27 and 28) in multiple steps to relieve spring tension gradually. Remove upper diaphragm case (24).
- E. Remove jam nut (23) and diaphragm washer (22).
- F. Remove the diaphragm (25), diaphragm plate (26), spring (21) and spring spacers (18) [if used].
- G. Invert the diaphragm (25) and diaphragm plate (26).
- H. Coat the actuator stem threads (10) and the surfaces of washer (22) with Dow Corning Sealant Compound III or equivalent.
- I. Checking placement of spacer (14) reassemble diaphragm (25), diaphragm plate (26), washer (22), jam nut (23) or travel stop (71) [see Note] in proper locations.

Note: The maximum stroke of each actuator size for model 88 uses Jam nut (23).

For other stroke, the travel stop (71) is used to replace the Jam nut (23).

Note: The model 88 size 10, 20.32mm [0.8"] stroke only uses Jam nut (23) and Travel stop (71).

Actuator Size	Stroke	Air to open Model 88	Air to close Model 87
6	20.32 mm [0.8"]	Jam nut (23)	Jam nut (23)
10	20.32 mm [0.8"]	Jam nut (23) and Travel stop (71)	
	38.1 mm [1.5"]	Jam nut (23)	
16	20.32 mm [0.8"]	Travel stop (71)	
	38.1 mm [1.5"]		
	50.8 mm [2.0"]		
23	63.5 mm [2.5"]	Jam nut (23)	
	20.32 mm [0.8"]	Travel stop (71)	
	38.1 mm [1.5"]		
	50.8 mm [2.0"]		
	63.5 mm [2.5"]	Jam nut (23)	

- J. Position springs (21) and spring spacers (18) [if used] in the diaphragm plate.
- K. Refer to Tables 1, 2 and 4 for spring information. Refer also to Section 8.1 F.
Note: Spring spacers (18) are not required for 0.8" (20mm) travel ranges.
Note: Arrange springs so that the coil ends are pointed toward the actuator stem as shown in Figure1. This step assures best actuator performance.
- L. Replace upper diaphragm case (24) and tension bolts (27 and 28).
Note: Tension bolts should be spaced equally around the bolt circle of the case.
- M. Tighten the tension bolts (27 and 28) in equal steps until the cases meet. Replace the remaining cap screws (20) and nuts (19).

CAUTION

Tighten cap screws and nuts evenly. Do not over tighten as this could possibly warp the diaphragm cases. See Table 3 for torque values.

- N. Position top and bottom stem connectors (2 and 4) and replace the two socket head cap screws (5) and recalibrate the seated position of the valve, (Section 10.1).
Note Size 6 actuator – Screw the plug stem back into the actuator stem (10) thru the stem flange (2) and recalibrate the seated position of the valve. If the actuator has been removed from the valve body, re-install it as indicated in Section 10.1).
Note: If the actuator has a handwheel, continue with the following steps.
- O. Swing the handwheel assembly back into place.
- P. It may require turning the handwheel (41) to position the lower pivot pins (33) under the stem connector (2-4), [stem flange (2) on the size 6 actuator].
- Q. Install the lever pin (45) and snap rings (46).
- R. Add the vent cap (59) to the top of upper diaphragm case.

9.4 Air to open to air to close (Model 88 to Model 87), size 3

- A. Shut off air supply to the actuator, isolate the control valve process pressure to eliminate the valve from moving with spring tension removed.
- B. If valve is equipped with a handwheel, please follow steps 7.2 B, C and D to disengage this assembly.
- C. Check the travel indicator on stem flange (2) against the travel scale (9) to ensure that the plug is up (off the seat).
- D. Loosen stem lock nuts (1).
- E. Re-tighten lock nuts (1) against each other so they will lock at a point that is not against the stem flange (2).
- F. Turn the stem lock nut (1) counterclockwise and loosen the plug stem until it disengages from the actuator stem (10).
Note: Depending on stem length, it may be required to separate the size 3 actuator off the valve body, as indicated in Section 6.1.
Note: Do not allow the plug to drop or turn against the seat ring, as this could damage the seat and plug.

- G. Remove four diaphragm case cap screws and nuts (27 and 28) leaving the other four installed on the case equally spaced.

CAUTION

Diaphragm case is under spring tension. The remaining four screws and nuts are tension bolts.

- H. Remove tension bolts (four remaining 27 and 28) in multiple steps to relieve spring tension gradually. Remove upper diaphragm case (24).
- I. Remove hex nut (23) and spacer (22), Figure 10.
- J. Remove diaphragm plate (26), diaphragm (25), and spacer (14), Figure 10.
- K. Place springs (21) [and spring spacers (18) if new range uses them] over the spring guides (29), Figure 9.
- L. Refer to Tables 1, 2 and 4 for spring information. Refer also to Section 8.3 K.
Note: Spring spacers (18) are not required for 0.8" (20mm) travel ranges
Note: Arrange springs so that the coil ends are pointed toward the actuator as shown in Figure 1. This step assures best actuator performance.
- M. Install spacer (22) on the actuator stem (10).
- N. Invert and replace the diaphragm plate (26) on the actuator stem (10) and over the springs.
- O. Install the diaphragm (25).
- P. Coat the threads of hex nut (23) and the surfaces of spacer (14) with Chesterton 725 nickel compound or equivalent. Install spacer (14) and tighten hex nut (23) per Table 3.
- Q. Replace upper diaphragm case (24) and tension bolts (four cap screws and nuts 27 and 28), and tighten per Table 3.
Note: Tension bolts should be spaced equally around the bolt circle of the case.
- R. Tighten the tension bolts (27 and 28) per Table 3 in equal steps until the cases meet. Replace the remaining cap screws (27) and nuts (28) and tighten per Table 3.

CAUTION

Tighten cap screws and nuts evenly. Do not over tighten as this could possibly warp the diaphragm cases. See Table 3 for torque values.

- S. Screw the plug stem back into the actuator stem (10) thru the stem flange and recalibrate the seated position of the valve.

Note: If the actuator has been removed from the valve body, reinstall it as indicated in Section 10.2.

Note: If the actuator has a handwheel, continue with the following steps:

- T. Hold the handwheel holder (40) in position between the yoke legs as shown in Figure 12 and slide the lever pin (45) through the hole in the yoke and lever. Be sure that levers (44) are above the stem flange (2).
- U. Secure the lever pin (45) with the second retaining ring (46).

9.5 Air to close to air to open (Model 87 to Model 88), size 3 with handwheel

CAUTION

The handwheel assembly can hold spring tension in the actuator when the diaphragm case is removed. To prevent possible injury, remove handwheel per the following procedure.

- A. Shut off air supply to the actuator, isolate the control valve process pressure to eliminate the valve from moving with spring tension removed.
- B. Rotate the handwheel (41) to a neutral position.
- C. Remove one of the two retaining rings (46) which are mounted on lever pin (45), Figure 12.

CAUTION

Removing the lever pin (45) will disconnect the handwheel assembly from the actuator. Support the handwheel assembly to avoid possible injury.

- D. Remove lever pin (45) and secure the handwheel holder (40) in place (see Figures 11 and 12). The handwheel assembly will be disconnected from the actuator.
- E. Proceed with the instructions for actuators without handwheel (9.6 Step B).

9.6 Air to close to air to open (Model 87 to Model 88), size 3 without handwheel

- A. Shut off air supply to the actuator and remove air piping from the upper diaphragm case (24).
- B. Check the travel indicator on stem flange (2) against the travel scale (9) to ensure that the plug is up (off the seat).
- C. Loosen stem lock nuts (1).
- D. Re-tighten lock nuts (1) against each other so they will lock at a point that is not against the stem flange (2).
- E. Turn the stem lock nut (1) counterclockwise and loosen the plug stem until it disengages from the actuator stem (10).

Note: Depending on stem length, it may be required to separate the size 3 actuator off the valve body, as indicated in Section 6.1.

Note: Do not allow the plug to drop or turn against the seat ring, as this could damage the seat and plug.

- F. Remove four diaphragm case cap screws and nuts (27 and 28) leaving the other four installed on the case equally spaced.

CAUTION

Diaphragm case is under spring tension. The remaining four screws and nuts are tension bolts.

- G. Remove tension bolts (four remaining 27 and 28) in multiple steps to relieve spring tension gradually. Remove upper diaphragm case (24).
- H. Remove hex nut (23) and spacer (14), Figure 9.
- I. Remove the diaphragm (25), diaphragm plate (26), spacer (22), spring (21) and spring spacers (18) [if used], Figure 9.
- J. Install spacer (14) on the actuator stem (10), Figure 10.
- K. Invert the diaphragm (25) and diaphragm plate (26), Figure 10.
- L. Coat the threads of hex nut (23) and the surfaces of spacer (22) with Chesterton 725 nickel compound or equivalent.
- M. Check placement of spacers (14 and 22), reassemble diaphragm (25), diaphragm plate (26), and spacer (22) then tighten hex nut (23) per Table 3.

- N. Position springs (21) and spring spacers (18) [if used] in the diaphragm plate.
- O. Refer to Tables 1, 2 and 4 for spring information. Refer also to Section 8.1.

Note: Arrange springs so that the coil ends are pointed toward the actuator as shown in Figure 1. This step assures best actuator performance.

- P. Replace upper diaphragm case (24) and tension bolts (four cap screws and nuts 27 and 28).

Note: Tension bolts should be spaced equally around the bolt circle of the case.

- Q. Tighten the tension bolts (27 and 28) in equal steps until the cases meet. Replace the remaining cap screws (27) and nuts (28).

CAUTION

Tighten cap screws and nuts evenly. Do not over tighten as this could possibly warp the diaphragm cases. See Table 3 for torque values.

- R. Screw the plug stem back into the actuator stem (10) thru the stem flange and recalibrate the seated position of the valve.

Note: If the actuator has been removed from the valve body, reinstall it as indicated in Section 10.1.

Note: If the actuator has a handwheel, continue with the following steps:

- S. Hold the handwheel holder (40) in position between the yoke legs as shown in Figure 12 and slide the lever pin (45) through the hole in the yoke and lever. Be sure that levers (44) are below the stem flange (2).
- T. Secure the lever pin (45) with the second retaining ring (46).

10. Valve Mounting

These installation and plug stem adjustment procedures are for mounting of the 87/88 Actuators on most metal seated reciprocating valves. Refer to the specific valve instructions for other trim types, such as pilot operated valves (41405) and soft seat designs.

CAUTION

The stem flange (2) on the size 3 and 6 is not fixed to the actuator stem and is a loose part with the stem nuts (1) backed off. For safety reasons, adjustments should only be made pneumatically.

10.1 Air to open (Model 88)

- A. Connect manual loading panel tubing to the lower diaphragm case or yoke connection (size 3).
- B. Apply required air pressure through the manual loading panel to completely retract the actuator stem (10).
- C. Install actuator on the valve body with drive nut. Tighten the drive nut.

Note: Size 3 and Size 6 actuator – Screw the plug stem into the actuator stem (10) thru the stem flange (2). Depending on stem length, it may be required to progressively lower the actuator forwards the body while screwing the plug stem into the actuator stem.

- D. On size 10, 16 and 23 actuators:

Apply initial air pressure and position top stem connector (4). Refer to Figure 14 and 16 for stem connector positioning.

On size 3 and 6 actuators:

Apply initial air pressure. Adjust the plug stem to position of stem flange (2) as shown in Figure 14.

CAUTION

DO NOT TURN the plug against the seat as damage to the parts can occur.

- E. Release air pressure.
- F. Using the stem lock nuts (1), unscrew the plug stem until the plug touches the seat.
- G. Pneumatically or with the handwheel, stroke the actuator to raise the plug off the seat. Unscrew the plug stem one full turn and lock the stem in place with the lock nut(s) (1) against the stem connector or flange (2 or 6).
- H. Line up the travel scale (9) with the pointer and check actuator for proper operation.

10.2 Air to close (Model 87)

- A. Install actuator on the valve body with drive nut. Tighten the drive nut.
- B. Position top and bottom stem connectors (2 and 4) and replace the two socket head cap screws (5). Turn the plug stem as far as possible into lower part of the stem connector (2 or 6). Refer to Figure 15 and Figure 16 for stem connector positioning.

Note: Size 3 and Size 6 actuator – Screw the plug stem into the actuator stem (10) thru the stem flange (2). Depending on stem length, it may be required to progressively lower the actuator forwards the body while screwing the plug stem into the actuator stem. Refer to Figure 15 for size 6 stem connector positioning.

- C. Pneumatically or with the handwheel, stroke the actuator to the rated spring range or stroke (if using the handwheel).
- D. Using the stem lock nuts (1) unscrew the plug stem until the plug touches the seat.

CAUTION

DO NOT TURN the plug against the seat as damage to the parts can occur.

- E. Release the pressure in the actuator or back off the handwheel to raise the stem.
- F. Unscrew the stem 1/2 turn and lock the stem in place by tightening the lock nuts (1) against the stem connector (2 or 6).

Note: Size 3 and Size 6 actuator – Lock the plug stem in place by tightening the lock nut (1) against the stem flange (2).

- H. Line up the travel scale (9) with the pointer and check actuator for proper operation.

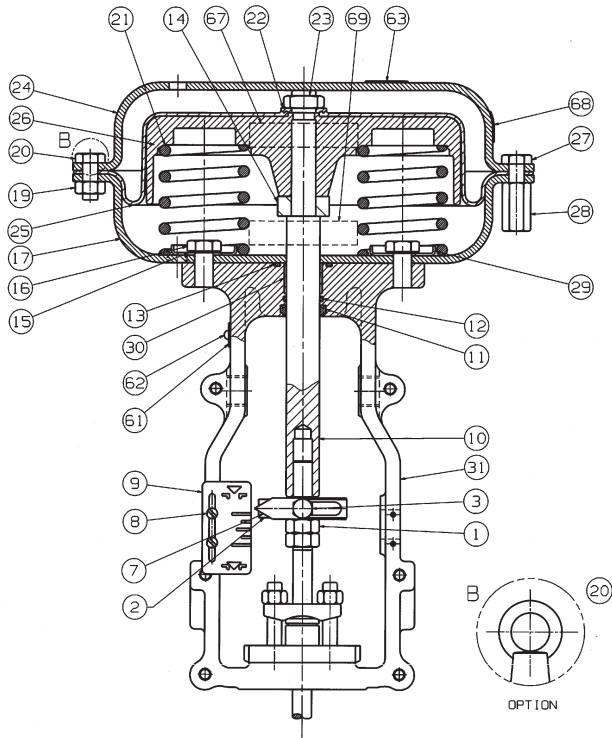

Figure 2. Size 6 Actuator
Air to Close (Model 87)

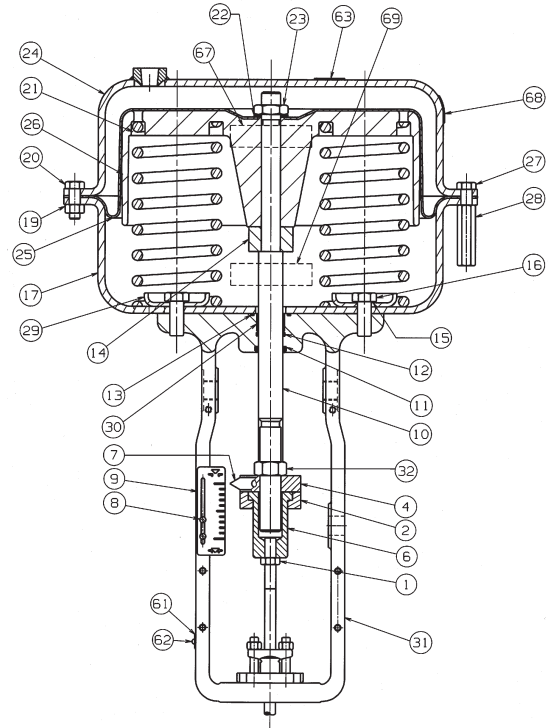

Figure 3. Size 10, 16 and 23 Actuator
Air to Close (Model 87)

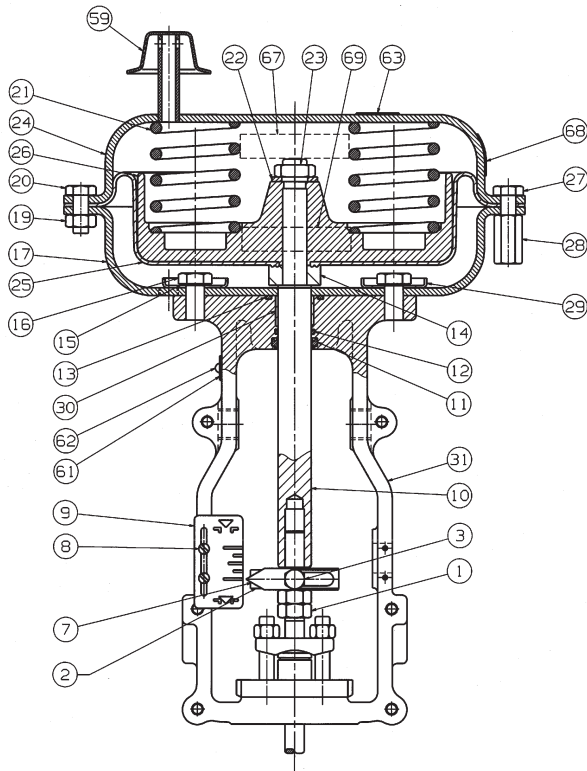

Figure 4. Size 6 Actuator
Air to Open (Model 88)

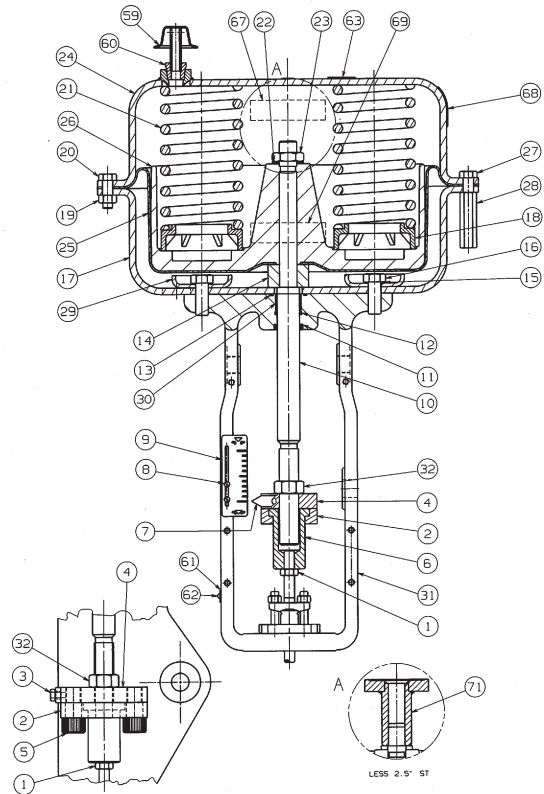

Figure 5. Size 10, 16 and 23 Actuator
Air to Open (Model 88)

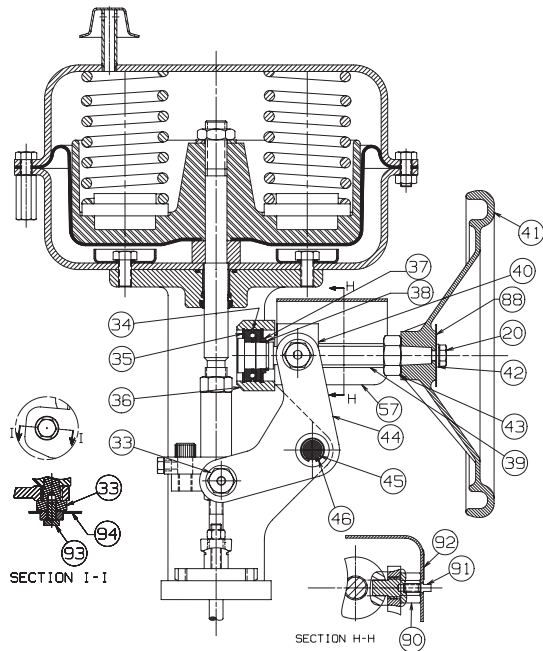

Figure 6. Size 6 and 10 Actuator with optional Handwheel

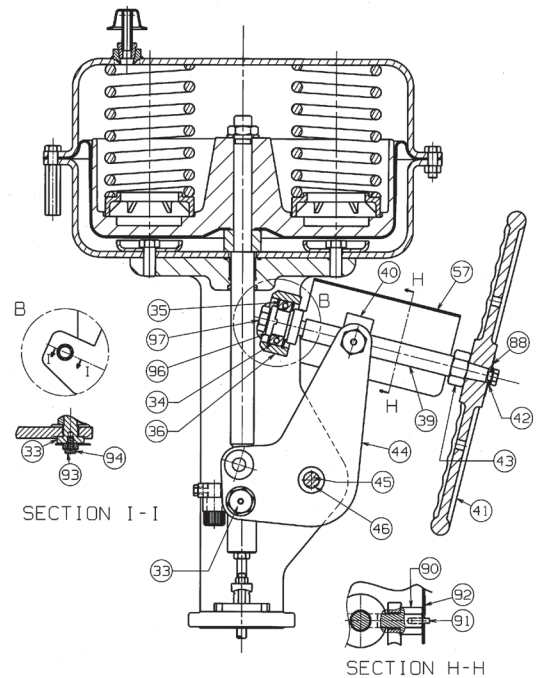

Figure 7. Size 16 and 23 Actuator with optional Handwheel

Parts Reference Table

Ref.No	Description	Ref.No	Description	Ref.No	Description
1	Lock Nut	22	Washer-Flat	43	HW Limitation Nut
■2	Stem Connector-Bottom	23	Nut-Jam	44	HW Lever
3	Cap Screw-Pointer	24	Upper Diaphragm Case	45	Lever Pin
★4	Stem Connector-Top	●25	Diaphragm	46	Retaining Ring-Lever Pin
★5	Cap Screw-Connector	26	Diaphragm Plate	57	HW Cover
★6	Connector Insert	27	Cap Screw-Comp	59	Vent Plug
7	Pointer	28	Compression Nut	▲60	Pipe Fitting
8	Screw-Pan Head	29	Spring Guide	63	Information Seal
9	Travel Scale	30	Bushing	67	Warning Seal
10	Actuator Stem	31	Yoke	68	Warning Seal - Arrow
●11	Stem Wiper	★32	Lock Nut	69	Warning Seal
●12	Oring	33	Pivot Pin	88	Plate-Rotation Arrow
●13	Oring	34	Thrust Bearing	90	Pivot Pin-HW Lock
14	Spacer	35	Retaining Ring	91	Handwheel Lock Pin
●15	Seal Washer	36	HW Pivot	92	Information Plate-HW
16	Cap Screw-Yoke	▲37	Bearing Ring	93	Cap Screw-Hex Head
17	Lower Diaphragm Case	▲38	Retaining Ring	94	Washer-Flat
18	Spring Spacer	39	HW Stem	96	End Flange
19	Hex Nut	40	Traveling Nut	97	Cap Screw-HW Stem
20	Cap Screw-Hex Head	41	Handwheel		
21	Spring	42	Washer-Flat		

- Recommended Spare Parts
- ★ Not provided for Size 6
- Stem Flange on Size 6 Actuator

▲ Not provided for Size 16 and 23

▲ Not provided for Size 6 and 10

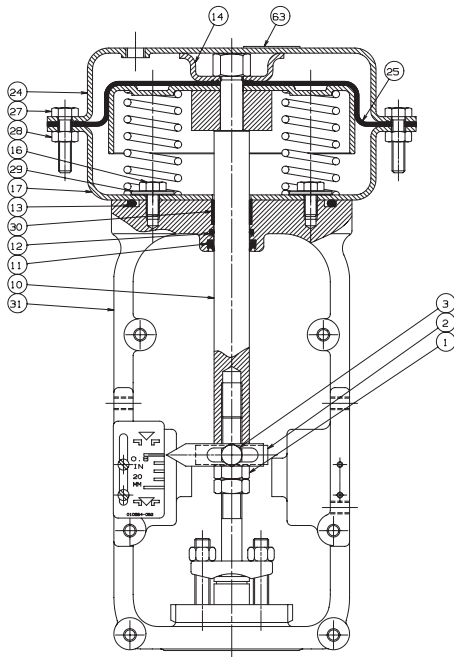

**Figure 9. Size 3 Actuator
Air to Close
(Model 87)**

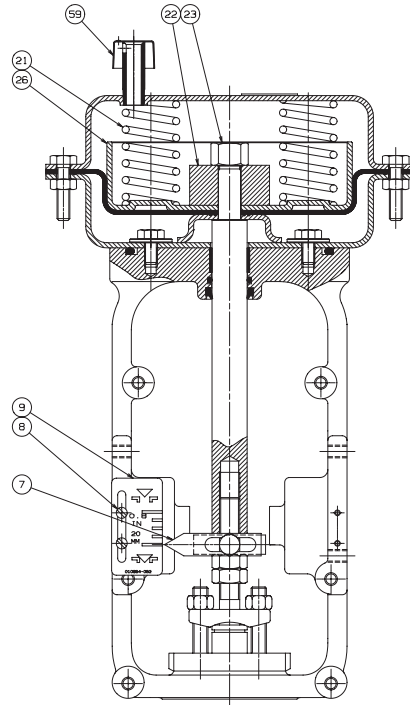

**Figure 10. Size 3 Actuator
Air to Open
(Model 88)**

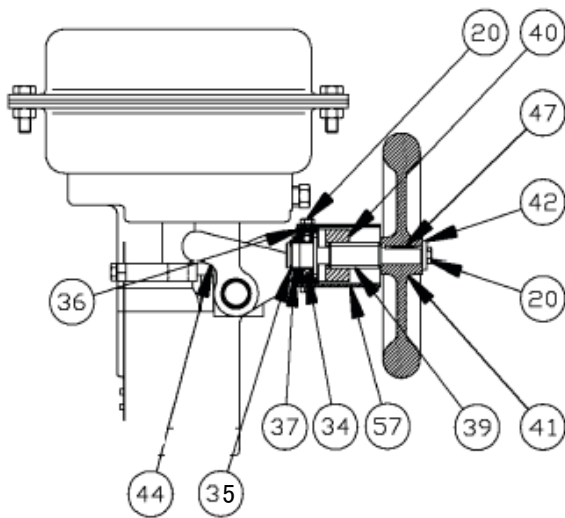

**Figure 11. Size 3 Actuator
Air to Close
With optional Handwheel**

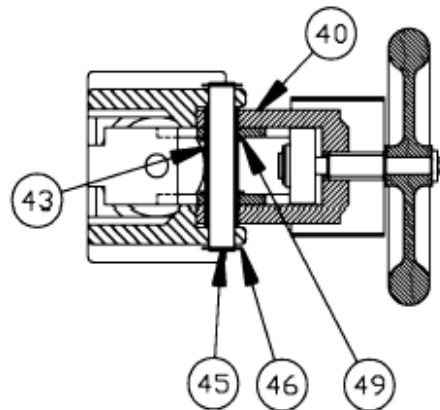

**Figure 12. Size 3 Actuator
Handwheel
sectional view**

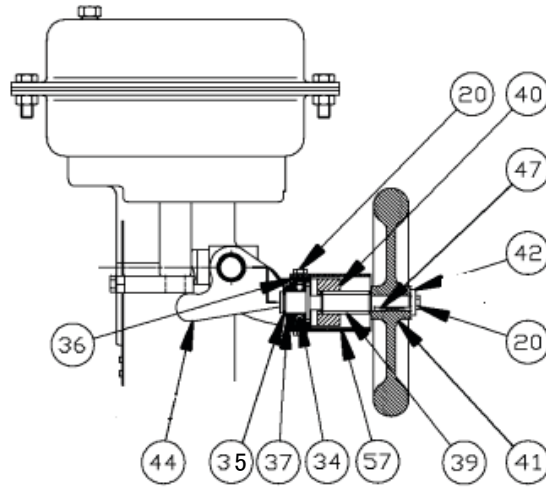

Figure 13. Size 3 Actuator Air to Open With optional Handwheel

Parts Reference Table – Size 3

Ref. No	Description	Ref. No	Description	Ref. No	Description	Ref. No	Description
2	Stem Flange	27	Cap Screw, Hex head	37	<u>Bushing</u>	44	<u>Handwheel Lever</u>
20	<u>Cap Screw, Hex head</u>	28	Hex Nut	40	<u>Handwheel Holder</u>	47	Key
22	Spacer	30	D.U. Bushing	43	Lever Assembly	49	Retaining Ring
23	Hex Nut	35	Retaining Ring				

Underlined: Optional Handwheel Only.

Note: All other Ref. Numbers and Descriptions are the same as listed for other sizes.

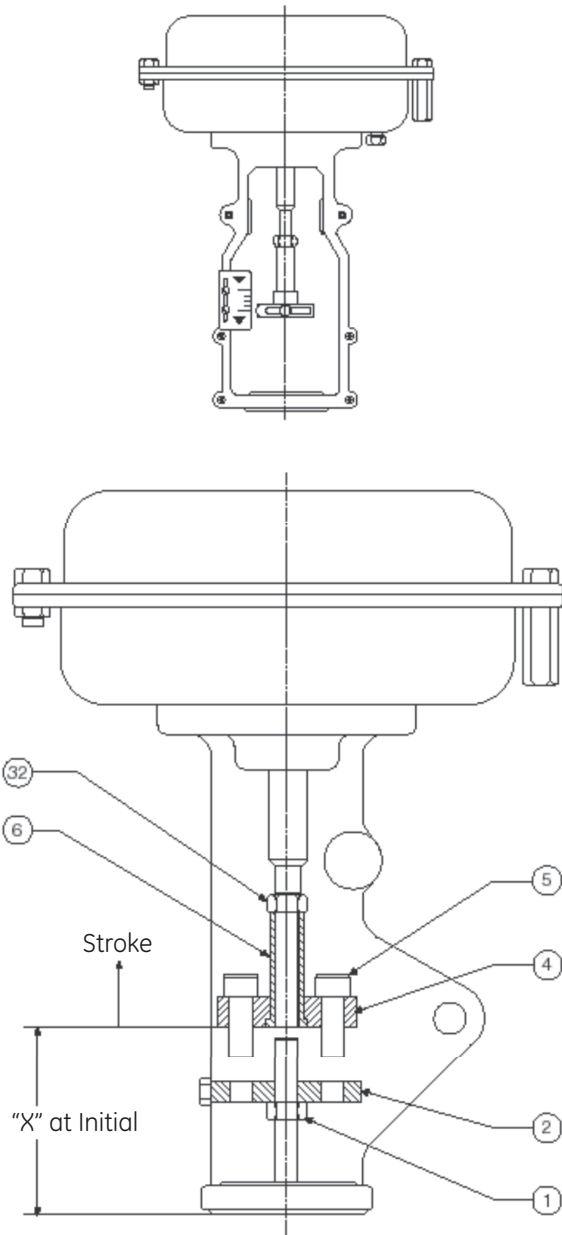

**Figure 14. Model 88 Actuator
Air to Open Actuator**

Actuator Size	Stroke	"X" at Initial PSI
3	0.8" (20mm)	3.55" (90.2mm)
6	0.8" (20mm)	3.54" (89.9mm)
10	0.8"-1.5" (20-38mm)	4.62" (117.4mm)

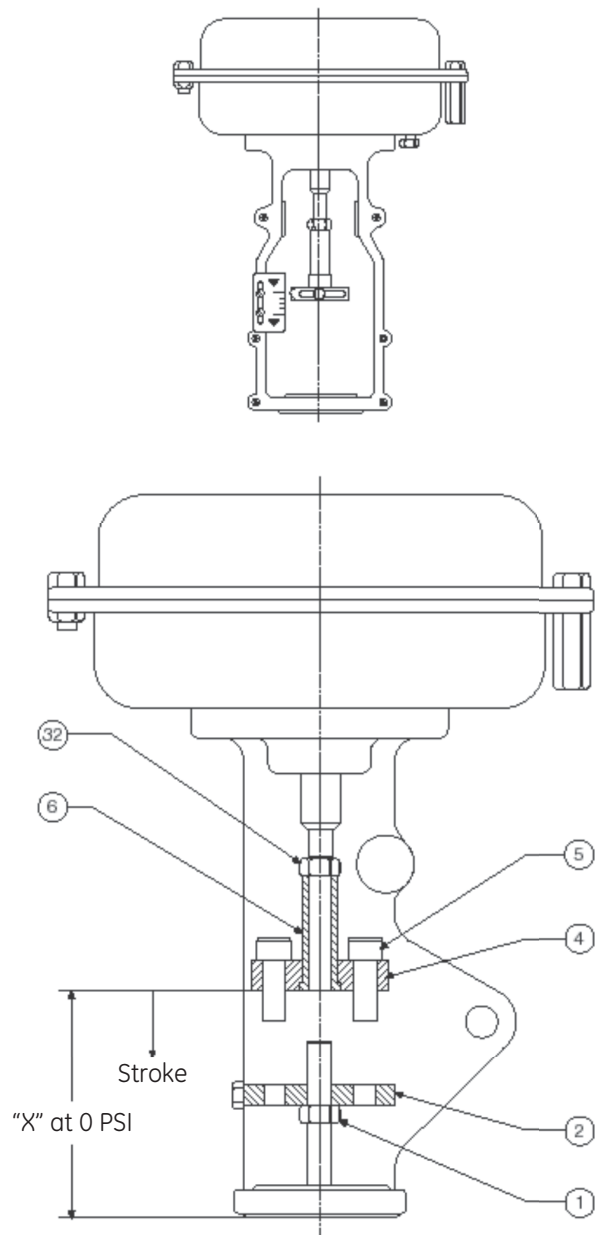

**Figure 15. Model 87 Actuator
Air to Close Actuator**

Actuator Size	Stroke	"X" at 0l PSI
3	0.8" (20mm)	4.56" (115.7mm)
6	0.8" (20mm)	4.48" (113.9mm)
10	0.8" (20mm)	5.12" (130.0mm)
	1.5" (38mm)	5.44" (138.2mm)

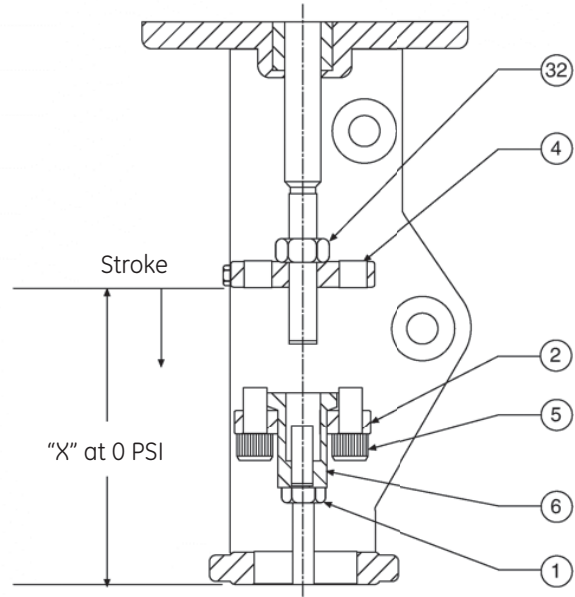
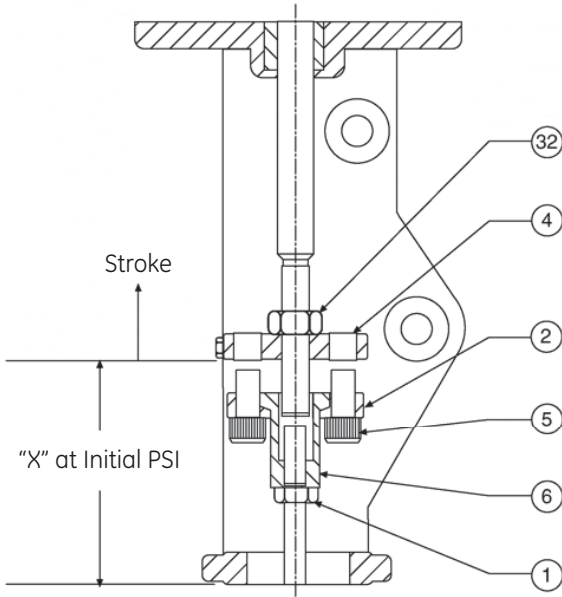
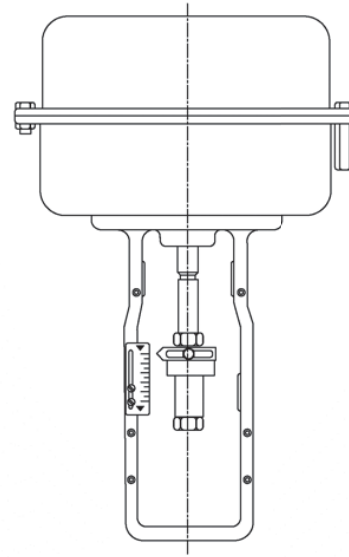
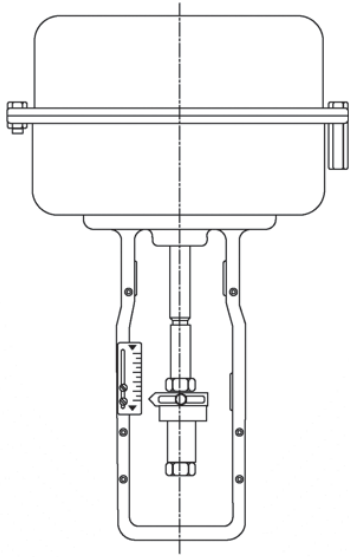

**Figure 16. Model 88 Actuator
Air to Open**

**Figure 17. Model 87 Actuator
Air to Close**

Actuator Size	Stroke	"X" at Initial PSI
16 & 23	0.8"-2.5 (20-64mm)	7.02" (178.3mm)

Actuator Size	Stroke	"X" at 0 PSI
16	0.8" (20mm)	8.00" (203.2mm)
	1.5" (38mm)	8.50" (215.9mm)
	2.0" (51mm)	9.28" (235.7mm)
	2.5" (64mm)	9.50" (241.3mm)
23	0.8" (20mm)	8.25" (209.6mm)
	1.5" (38mm)	8.62" (218.9mm)
	2.0" (51mm)	9.12" (231.6mm)
	2.5" (64mm)	9.59" (243.6mm)

Notes

DIRECT SALES OFFICE LOCATIONS

AUSTRALIA

Brisbane:
Phone: +61-7-3001-4319
Fax: +61-7-3001-4399

Perth:
Phone: +61-8-6595-7018
Fax: +61 8 6595-7299

Melbourne:
Phone: +61-3-8807-6002
Fax: +61-3-8807-6577

BELGIUM

Phone: +32-2-344-0970
Fax: +32-2-344-1123

BRAZIL

Phone: +55-11-2146-3600
Fax: +55-11-2146-3610

CHINA

Phone: +86-10-5689-3600
Fax: +86-10-5689-3800

FRANCE

Courbevoie
Phone: +33-1-4904-9000
Fax: +33-1-4904-9010

GERMANY

Ratingen
Phone: +49-2102-108-0
Fax: +49-2102-108-111

INDIA

Mumbai
Phone: +91-22-8354790
Fax: +91-22-8354791

New Delhi

Phone: +91-11-2-6164175
Fax: +91-11-5-1659635

ITALY

Phone: +39-081-7892-111
Fax: +39-081-7892-208

JAPAN

Chiba
Phone: +81-43-297-9222
Fax: +81-43-299-1115

KOREA

Phone: +82-2-2274-0748
Fax: +82-2-2274-0794

MALAYSIA

Phone: +60-3-2161-0322
Fax: +60-3-2163-6312

MEXICO

Phone: +52-55-3640-5060

THE NETHERLANDS

Phone: +0031-15-3808666
Fax: +0031-18-1641438

RUSSIA

Veliky Novgorod
Phone: +7-8162-55-7898
Fax: +7-8162-55-7921

Moscow

Phone: +7 495-585-1276
Fax: +7 495-585-1279

SAUDI ARABIA

Phone: +966-3-341-0278
Fax: +966-3-341-7624

SINGAPORE

Phone: +65-6861-6100
Fax: +65-6861-7172

SOUTH AFRICA

Phone: +27-11-452-1550
Fax: +27-11-452-6542

SOUTH & CENTRAL AMERICA AND THE CARIBBEAN

Phone: +55-12-2134-1201
Fax: +55-12-2134-1238

SPAIN

Phone: +34-93-652-6430
Fax: +34-93-652-6444

UNITED ARAB EMIRATES

Phone: +971-4-8991-777
Fax: +971-4-8991-778

UNITED KINGDOM

Bracknell
Phone: +44-1344-460-500
Fax: +44-1344-460-537

Skelmersdale

Phone: +44-1695-526-00
Fax: +44-1695-526-01

UNITED STATES

Massachusetts
Phone: +1-508-586-4600
Fax: +1-508-427-8971

Corpus Christi, Texas

Phone: +1-361-881-8182
Fax: +1-361-881-8246

Deer Park, Texas

Phone: +1-281-884-1000
Fax: +1-281-884-1010

Houston, Texas

Phone: +1-281-671-1640
Fax: +1-281-671-1735



* Denotes a registered trademark of the General Electric Company.

Other company names and product names used in this document are the registered trademarks or trademarks of their respective owners.

© 2015 General Electric Company. All rights reserved.

GEA19530B 07/2015