

Consolidated* Valves

2900 MPV Series

Pilot-Operated Safety Relief Valve

A unique design that combines top performance, capabilities and features within an economical, modular assembly.



Table of Contents

Conversion Table	3
2900 Flanged Series Overview	4-9
2900 Series Conventional Type Main Valve (Metal Seat).....	10-11
2900 Series Bellows Type Main Valve.....	12-13
2900 Series Soft Seats (DA).....	14-15
How the Double Seal Works.....	16
2900 Series Steam Trim (TD) Valves	17
2900 Series Special Material Options	18-28
Soft Goods Selection	29-30
Pilot Designs	31-32
Pilot Materials (PV).....	33-39
Pilot Special Materials (PV)	40-42
Pilot Materials (MV).....	43-45
Pilot Special Materials (MV)	46-58
Pilot Design Options.....	59-65
Piping Configurations	66-80
Valve Installation	81
Dimensions & Weights	82-90
Pressure/Temperature.....	91-108
Capacities.....	109-114
Valve Configuration Code	115-119
Ordering BHGE's 2900 MPV Series Safety Relief Valve	120

BHGE provides a full range of Consolidated* pressure relief valve styles, sizes, options and configurations for multiple industries, applications, environments, and media. From spring-actuated to pilot-operated, each pressure relief valve is configured to offer safer process flow control in harsh environments.

Conversion Table

All the USCS values are converted to metric values using the following conversion factors:

Metric values using the following conversion factors:	Conversion Factor	Metric Unit
in.	25.4	mm
lb.	0.4535924	kg
in ²	6.4516	cm ²
ft ³ /min	0.02831685	m ³ /min
gal/min	3.785412	L/min
lb/hr	0.4535924	kg/hr
psig	0.06894757	barg
ft lb	1.3558181	Nm
°F	5/9 (°F-32)	°C

Scope of Design

2900 Flanged Series Valve Overview

The Consolidated 2900 series pilot-operated safety relief valve is supplied with the same non-flowing pilot valve used on the 3900 series POSRV. This single-pilot design is suitable for both incompressible and compressible applications and performs equally well on liquid, vapor or two-phase flow services.. The set pressure will not require adjustment if the service condition changes. A metal seat on the main valve is standard, and an O-ring option is available.

Product types			
Product Type	Pilot Type	Service	Description
2900	39PV	gas/liquid	pop action - non flowing
2900	39MV	gas/liquid	modulating - non flowing
2900	39PVSS	steam	pop action - non flowing
2900	39MVSS	steam	modulating - non flowing

Because of its modular design, the 39PV07 (pop pilot) can be converted to a 39MV07 (modulator pilot). However, the 39PV37 pop-action pilot is not convertible to a 39MV22 modulating pilot. Adding a heat exchanger expands the range of the 2900 to meet high and low temperature requirements. That makes it one of the most versatile pilot-operated safety relief valves available. (The scope of the 2900 series is outlined in this section.)

Standard Valve Connection - D Orifice						
Orifice Area	API			ASME		
	in ²	0.110	in ²	0.128		
	cm ²	0.710	cm ²	0.825		
Valve Type	Inlet			Outlet		
	Size		ANSI Std. Class	Size		ANSI Std. Class
	in.	mm		in.	mm	
2905	1.00	25.4	150	2.00	50.8	150
2906	1.00	25.4	300	2.00	50.8	150
2910	1.00	25.4	300	2.00	50.8	150
2912	1.00	25.4	600	2.00	50.8	150
2914	1.50	38.1	900	2.00	50.8	300
2916	1.50	38.1	1500	2.00	50.8	300
2918	1.50	38.1	2500	3.00	76.2	300
2920	1.00	25.4	300	2.00	50.8	150
2922	1.00	25.4	600	2.00	50.8	150
2924	1.50	38.1	900	2.00	50.8	300
2926	1.50	38.1	1500	2.00	50.8	300
2928	1.50	38.1	2500	3.00	76.2	300

Standard Valve Connection - E Orifice						
Orifice Area	API			ASME		
	in ²	0.196	in ²	0.228		
	cm ²	1.265	cm ²	1.470		
Valve Type	Inlet			Outlet		
	Size		ANSI Std. Class	Size		ANSI Std. Class
	in.	mm		in.	mm	
2905	1.00	25.4	150	2.00	50.8	150
2906	1.00	25.4	300	2.00	50.8	150
2910	1.00	25.4	300	2.00	50.8	150
2912	1.00	25.4	600	2.00	50.8	150
2914	1.50	38.1	900	2.00	50.8	300
2916	1.50	38.1	1500	2.00	50.8	300
2918	1.50	38.1	2500	3.00	76.2	300
2920	1.00	25.4	300	2.00	50.8	150
2922	1.00	25.4	600	2.00	50.8	150
2924	1.50	38.1	900	2.00	50.8	300
2926	1.50	38.1	1500	2.00	50.8	300
2928	1.50	38.1	2500	3.00	76.2	300

Scope of Design

2900 Flanged Series Valve Overview

Standard Valve Connection - F Orifice						
Orifice Area	API			ASME		
	in ²	0.307		in ²	0.357	
	cm ²	1.981		cm ²	2.302	
Valve Type	Inlet			Outlet		
	Size		ANSI Std. Class	Size		ANSI Std. Class
	in.	mm		in.	mm	
2905	1.50	38.1	150	2.00	50.8	150
2906	1.50	38.1	300	2.00	50.8	150
2910	1.50	38.1	300	2.00	50.8	150
2912	1.50	38.1	600	2.00	50.8	150
2914	1.50	38.1	900	3.00	76.2	300
2916	1.50	38.1	1500	3.00	76.2	300
2918	1.50	38.1	2500	3.00	76.2	300
2920	1.50	38.1	300	2.00	50.8	150
2922	1.50	38.1	600	2.00	50.8	150
2924	1.50	38.1	900	3.00	76.2	300
2926	1.50	38.1	1500	3.00	76.2	300
2928	1.50	38.1	2500	3.00	76.2	300

Standard Valve Connection - G Orifice						
Orifice Area	API			ASME		
	in ²	0.503		in ²	0.585	
	cm ²	3.245		cm ²	3.774	
Valve Type	Inlet			Outlet		
	Size		ANSI Std. Class	Size		ANSI Std. Class
	in.	mm		in.	mm	
2905	1.50	38.1	150	3.00	76.2	150
2906	1.50	38.1	300	3.00	76.2	150
2910	1.50	38.1	300	3.00	76.2	150
2912	1.50	38.1	600	3.00	76.2	150
2914	1.50	38.1	900	3.00	76.2	300
2916	2.00	50.8	1500	3.00	76.2	300
2918	2.00	50.8	2500	3.00	76.2	300
2920	1.50	38.1	300	3.00	76.2	150
2922	1.50	38.1	600	3.00	76.2	150
2924	1.50	38.1	900	3.00	76.2	300
2926	2.00	50.8	1500	3.00	76.2	300
2928	2.00	50.8	2500	3.00	76.2	300

Standard Valve Connection - H Orifice						
Orifice Area	API			ASME		
	in ²	0.785		in ²	0.913	
	cm ²	5.065		cm ²	5.888	
Valve Type	Inlet			Outlet		
	Size		ANSI Std. Class	Size		ANSI Std. Class
	in.	mm		in.	mm	
2905	1.50	38.1	150	3.00	76.2	150
2906	1.50	38.1	300	3.00	76.2	150
2910	2.00	50.8	300	3.00	76.2	150
2912	2.00	50.8	600	3.00	76.2	150
2914	2.00	50.8	900	3.00	76.2	150
2916	2.00	50.8	1500	3.00	76.2	300
2920	2.00	50.8	300	3.00	76.2	150
2922	2.00	50.8	600	3.00	76.2	150
2924	2.00	50.8	900	3.00	76.2	150
2926	2.00	50.8	1500	3.00	76.2	300

Standard Valve Connection - J Orifice						
Orifice Area	API			ASME		
	in ²	1.287		in ²	1.496	
	cm ²	8.303		cm ²	9.652	
Valve Type	Inlet			Outlet		
	Size		ANSI Std. Class	Size		ANSI Std. Class
	in.	mm		in.	mm	
2905	2.00	50.8	150	3.00	76.2	150
2906	2.00	50.8	300	3.00	76.2	150
2910	3.00	76.2	300	4.00	101.6	150
2912	3.00	76.2	600	4.00	101.6	150
2914	3.00	76.2	900	4.00	101.6	150
2916	3.00	76.2	1500	4.00	101.6	300
2920	3.00	76.2	300	4.00	101.6	150
2922	3.00	76.2	600	4.00	101.6	150
2924	3.00	76.2	900	4.00	101.6	150
2926	3.00	76.2	1500	4.00	101.6	300

Scope of Design

2900 Flanged Series Valve Overview

Standard Valve Connection - K Orifice						
Orifice Area	API			ASME		
	in ²	1.838		in ²	2.138	
	cm ²	11.858		cm ²	13.794	
Valve Type	Inlet			Outlet		
	Size		ANSI Std. Class	Size		ANSI Std. Class
	in.	mm		in.	mm	
2905	3.00	76.2	150	4.00	101.6	150
2906	3.00	76.2	300	4.00	101.6	150
2910	3.00	76.2	300	4.00	101.6	150
2912	3.00	76.2	600	4.00	101.6	150
2914	3.00	76.2	900	6.00	152.4	150
2916	3.00	76.2	1500	6.00	152.4	300
2920	3.00	76.2	300	4.00	101.6	150
2922	3.00	76.2	600	4.00	101.6	150
2924	3.00	76.2	900	6.00	152.4	150
2926	3.00	76.2	1500	6.00	152.4	300

Standard Valve Connection - L Orifice						
Orifice Area	API			ASME		
	in ²	2.853		in ²	3.317	
	cm ²	18.406		cm ²	21.400	
Valve Type	Inlet			Outlet		
	Size		ANSI Std. Class	Size		ANSI Std. Class
	in.	mm		in.	mm	
2905	3.00	76.2	150	4.00	101.6	150
2906	3.00	76.2	300	4.00	101.6	150
2910	4.00	101.6	300	6.00	152.4	150
2912	4.00	101.6	600	6.00	152.4	150
2914	4.00	101.6	900	6.00	152.4	150
2916	4.00	101.6	1500	6.00	152.4	150
2920	4.00	101.6	300	6.00	152.4	150
2922	4.00	101.6	600	6.00	152.4	150
2924	4.00	101.6	900	6.00	152.4	150
2926	4.00	101.6	1500	6.00	152.4	150

Standard Valve Connection - M Orifice						
Orifice Area	API			ASME		
	in ²	3.600		in ²	4.186	
	cm ²	23.226		cm ²	27.006	
Valve Type	Inlet			Outlet		
	Size		ANSI Std. Class	Size		ANSI Std. Class
	in.	mm		in.	mm	
2905	4.00	101.6	150	6.00	152.4	150
2906	4.00	101.6	300	6.00	152.4	150
2910	4.00	101.6	300	6.00	152.4	150
2912	4.00	101.6	600	6.00	152.4	150
2914	4.00	101.6	900	6.00	152.4	150
2920	4.00	101.6	300	6.00	152.4	150
2922	4.00	101.6	600	6.00	152.4	150
2924	4.00	101.6	900	6.00	152.4	150

Standard Valve Connection - N Orifice						
Orifice Area	API			ASME		
	in ²	4.340		in ²	5.047	
	cm ²	28.000		cm ²	32.561	
Valve Type	Inlet			Outlet		
	Size		ANSI Std. Class	Size		ANSI Std. Class
	in.	mm		in.	mm	
2905	4.00	101.6	150	6.00	152.4	150
2906	4.00	101.6	300	6.00	152.4	150
2910	4.00	101.6	300	6.00	152.4	150
2912	4.00	101.6	600	6.00	152.4	150
2914	4.00	101.6	900	6.00	152.4	150
2920	4.00	101.6	300	6.00	152.4	150
2922	4.00	101.6	600	6.00	152.4	150
2924	4.00	101.6	900	6.00	152.4	150

Standard Valve Connection - P Orifice						
Orifice Area	API			ASME		
	in ²	6.380		in ²	7.417	
	cm ²	41.161		cm ²	47.852	
Valve Type	Inlet			Outlet		
	Size		ANSI Std. Class	Size		ANSI Std. Class
	in.	mm		in.	mm	
2905	4.00	101.6	150	6.00	152.4	150
2906	4.00	101.6	300	6.00	152.4	150
2910	4.00	101.6	300	6.00	152.4	150
2912	4.00	101.6	600	6.00	152.4	150
2914	4.00	101.6	900	6.00	152.4	150
2920	4.00	101.6	300	6.00	152.4	150
2923	4.00	101.6	600	6.00	152.4	150
2924	4.00	101.6	900	6.00	152.4	150

Standard Valve Connection - Q Orifice						
Orifice Area	API			ASME		
	in ²	11.050		in ²	12.850	
	cm ²	71.290		cm ²	82.903	
Valve Type	Inlet			Outlet		
	Size		ANSI Std. Class	Size		ANSI Std. Class
	in.	mm		in.	mm	
2905	6.00	152.40	150	8.00	203.2	150
2906	6.00	152.40	300	8.00	203.2	150
2910	6.00	152.40	300	8.00	203.2	150
2912	6.00	152.40	600	8.00	203.2	150
2920	6.00	152.40	300	8.00	203.2	150
2922	6.00	152.40	600	8.00	203.2	150

Scope of Design

2900 Flanged Series Valve Overview

Standard Valve Connection - R Orifice						
Orifice Area	API			ASME		
	in ²	16.000		in ²	18.600	
	cm ²	103.226		cm ²	120.000	
Valve Type	Inlet			Outlet		
	Size		ANSI Std. Class	Size		ANSI Std. Class
	in.	mm		in.	mm	
2905	6.00	152.4	150	8.00	203.2	150
2906	6.00	152.4	300	8.00	203.2	150
2910	6.00	152.4	300	10.00	254.0	150
2912	6.00	152.4	600	10.00	254.0	150
2920	6.00	152.4	300	10.00	254.0	150
2922	6.00	152.4	600	10.00	254.0	150

Standard Valve Connection - T Orifice						
Orifice Area	API			ASME		
	in ²	26.000		in ²	30.210	
	cm ²	167.740		cm ²	194.900	
Valve Type	Inlet			Outlet		
	Size		ANSI Std. Class	Size		ANSI Std. Class
	in.	mm		in.	mm	
2905	8.00	203.2	150	10.00	254.0	150
2906	8.00	203.2	300	10.00	254.0	150
2910	8.00	203.2	300	10.00	254.0	150
2912	8.00	203.2	600	10.00	254.0	150
2920	8.00	203.2	300	10.00	254.0	150
2922	8.00	203.2	600	10.00	254.0	150

Standard Valve Connection - U Orifice						
Orifice Area	API			ASME		
	in ²	N/A		in ²	35.000	
	cm ²	N/A		cm ²	225.806	
Valve Type	Inlet			Outlet		
	Size		ANSI Std. Class	Size		ANSI Std. Class
	in.	mm		in.	mm	
2905	8.00	203.2	150	10.00	254.0	150
2906	8.00	203.2	300	10.00	254.0	150
2910	8.00	203.2	300	10.00	254.0	150
2912	8.00	203.2	600	10.00	254.0	150
2920	8.00	203.2	300	10.00	254.0	150
2922	8.00	203.2	600	10.00	254.0	150

Standard Valve Connection - V Orifice						
Orifice Area	API			ASME		
	in ²	N/A		in ²	50.260	
	cm ²	N/A		cm ²	324.257	
Valve Type	Inlet			Outlet		
	Size		ANSI Std. Class	Size		ANSI Std. Class
	in.	mm		in.	mm	
2905	10.00	254.0	150	14.00	355.6	150
2906	10.00	254.0	300	14.00	355.6	150
2910	10.00	254.0	300	14.00	355.6	150
2920	10.00	254.0	300	14.00	355.6	150

Standard Valve Connection - W Orifice						
Orifice Area	API			ASME		
	in ²	N/A		in ²	78.996	
	cm ²	N/A		cm ²	509.651	
Valve Type	Inlet			Outlet		
	Size		ANSI Std. Class	Size		ANSI Std. Class
	in.	mm		in.	mm	
2905	12.00	304.8	150	16.00	406.4	150
2906	12.00	304.8	300	16.00	406.4	150
2910	12.00	304.8	300	16.00	406.4	150
2920	12.00	304.8	300	16.00	406.4	150

Scope of Design

2900 Flanged Series Valve Overview

Pressure Limits ^{1,2 & 5}						
Product Type	Pilot Type	Minimum		Maximum		Service
		psig	barg	psig	barg	
2900	39PV	15	1.03	3750	258.55	gas/liquid
2900	39MV	15	1.03	6250	430.92	gas/liquid
2900 w/ heat exchanger	39PV	15	1.03	3750	258.55	gas/liquid
2900 w/ heat exchanger	39MV	15	1.03	6250	430.92	gas/liquid
2900	39PVSS	15	1.03	750	398.9	steam
2900	39MVSS	15	1.03	750	398.9	steam
2900 w/ heat exchanger	39PVSS	15	1.03	2903	1595.0	steam
2900 w/ heat exchanger	39MVSS	15	1.03	2903	1595.0	steam

Temperature Limits ^{1,2 & 5}						
Product Type	Pilot Type	Minimum		Maximum		Service
		(°F)	(°C)	(°F)	(°C)	
2900	39PV	-40	-40.0	505	262.8	gas/liquid
2900	39MV	-40	-40.0	505	262.8	gas/liquid
2900 w/ heat exchanger	39PV	-450	-267.8	1200	648.9	gas/liquid
2900 w/ heat exchanger	39MV	-450	-267.8	1200	648.9	gas/liquid
2900	39PVSS	212	100.0	505	262.8	steam
2900	39MVSS	212	100.0	505	262.8	steam
2900 w/ heat exchanger	39PVSS	212	100.0	1200	648.9	steam
2900 w/ heat exchanger	39MVSS	212	100.0	1200	648.9	steam

Soft Goods Guide ^{3,4 & 5}																	
Service	Material	Pilot Valve and Modulator								Main Valve							
		Temperature Range				Pressure Range				Temperature Range				Pressure Range			
		min.		max.		min.		max.		min.		max.		min.		max.	
		(°F)	(°C)	(°F)	(°C)	psig	barg	psig	barg	(°F)	(°C)	(°F)	(°C)	psig	barg	psig	barg
liquid/gas	Nitrile (Buna N)	-40	-40.0	250	121.1	15	1.03	6250	430.92	-40	-40.0	250	121.1	15	1.03	3750	258.55
liquid/gas	Fluorocarbon (Viton®)	-15	-26.1	400	204.4	15	1.03	6250	430.92	-15	-26.1	400	204.4	15	1.03	3750	258.55
liquid/gas	Ethylene Propylene	-40	-40.0	500	260.0	15	1.03	3750	258.55	-40	-40.0	250	121.1	15	1.03	3750	258.55
liquid/gas	Kalrez®	-40	-40.0	505	262.8	15	1.03	6250	430.92	-4	-20.0	601	316.1	15	1.03	3750	258.55
liquid/gas	Teflon®	-40	-40.0	505	262.8	50	3.45	6250	430.92	-40	-40.0	505	262.8	50	3.45	6250	430.92
liquid/gas	Neoprene	N/A	N/A	N/A	N/A	N/A	N/A	N/A	N/A	-45	-42.8	300	148.9	15	1.03	800	55.16
liquid/gas	Silicone	N/A	N/A	N/A	N/A	N/A	N/A	N/A	N/A	-40	-40.0	437	225.0	15	1.03	800	55.16
liquid/gas	Chemraz®	N/A	N/A	N/A	N/A	N/A	N/A	N/A	N/A	-20	-28.9	500	260.0	-20	-1.38	3750	258.55
steam	Ethylene Propylene	212	100.0	500	260.0	15	1.03	49	3.38	212	100.0	500	260.0	15	1.03	49	3.38
steam	Teflon®	212	100.0	505	262.8	50	3.45	3750	258.55	212	100.0	505	262.8	50	3.45	3750	258.55

Notes:

1. The above table is general in nature and is to be used as a guideline only.
2. Refer to the Pressure/Temperature Tables beginning on page 2900.91 for actual pressure limits at a given temperature by orifice and materials of construction.
3. Refer to the Soft Goods Selection Table on page 2900.29 for material selection for a given pressure, temperature, fluid type, durometer hardness and orifice size.
4. When the pressure/temperature limits of the soft goods in the pilot valve and main valve are exceeded, the heat exchanger must be used to condition the media to within an acceptable range. A standard metal seat is used on the main base with the heat exchanger.
5. Sizing of the heat exchanger is required and may not be suitable for all applications.

Scope of Design

2900 Flanged Series Valve Overview

Applications		
Applications	Pilot Type	
	39PV	39MV
Type		
Pop Action - Non Flowing	Yes	No
Modulating - Non Flowing	No	Yes
Media		
Air, Gas	Yes	Yes
Vapor	Yes	Yes
Dirty Vapor (filter required)	Yes	Yes
Steam	Yes	Yes
Liquid	Yes	Yes
Operational Conditions		
Icing	Yes	Yes
Pulsations	Yes	Yes
Reduces Water Hammer (when valve closes)	Yes	Yes
Operational Performance ^{1,2,4}		
Pressure Range:		
15-3750 psig (1.03-258.55 barg) (Gas/Liquid/Vapor)	Yes	Yes
15-6250 psig (1.03-430.92 barg) (Gas/Liquid/Vapor)	No	Yes
15-3750 psig (1.03-258.55 barg) (Steam)	Yes	Yes
Blowdown: 2% to 7% adjustable	Yes	Yes
Main Valve Seat Tightness (% of set pressure):		
Metal Seat - Per API 527	98%	98%
Soft Seat - Bubble Tight	98%	98%
Back Pressure (with pilot vented to body bowl):⁵		
Variable - % of Set Pressure	15%	65%
Constant - % of Set Pressure	65% ³	65%
Back Pressure (with pilot vented to atmosphere):⁵		
Variable - % of Set Pressure	97%	97%
Constant - % of Set Pressure	97%	97%
Temperature: Without Heat Exchanger	-40°F to 505°F (-40.0°C to 262.8°C)	-40°F to 505°F (-40.0°C to 262.8°C)
With Heat Exchanger ⁴	-450° F to 1200°F (-267.8°C to 648.9°C)	-450°F to 1200°F (-267.8°C to 648.9°C)

Notes:

1. Review Pressure/Temperature tables.
2. Review Outlet Flange Ratings and Capacity Correction Factor.
3. A Cold Differential Test Pressure (CDTP) must be applied for a 39PV when the constant back pressure is over 15% of set pressure.
4. Use of a Heat Exchanger is subject to sizing and may not be suitable for all applications.
5. If backflow preventer is installed, total backpressure is limited to 65%.

Options		
Options	Pilot Type	
	39PV	39MV
Backflow Preventer	Yes	Yes
Bonnet (vented) ²	Yes	Yes
Dirty Service	Yes	Yes
Dual Filters	Yes	Yes
Dual Pilots	Yes	Yes
Heat Exchanger ³	Yes	Yes
High Capacity Line Filter (with flush valve)	Yes	Yes
Optional Sensing Line Filter (standard for steam service)	Yes	Yes
Pilot Discharge to Body Bowl	Yes	Yes
Pressure Differential Switch	Yes	Yes
Remote Actuated Blowdown	Yes	Yes
Remote Pilot Mounting	Yes	Yes
Remote Sense (Standard) ¹	Yes	Yes
Sensing Ring	Yes	Yes

Notes:

1. The standard product is supplied with the remote sense connection. It must be piped to the system pressure or the sensing ring option must be used.
2. When vented bonnet option is selected for steam service, an Inconel X750 spring id supplied.
3. Use of a Heat Exchanger is subject to sizing and may not be suitable for all applications.

Main Valve Materials

2900 Conventional Type Main Valve (Metal Seat)

Main Valve - Metal Seat (D-U Orifices)

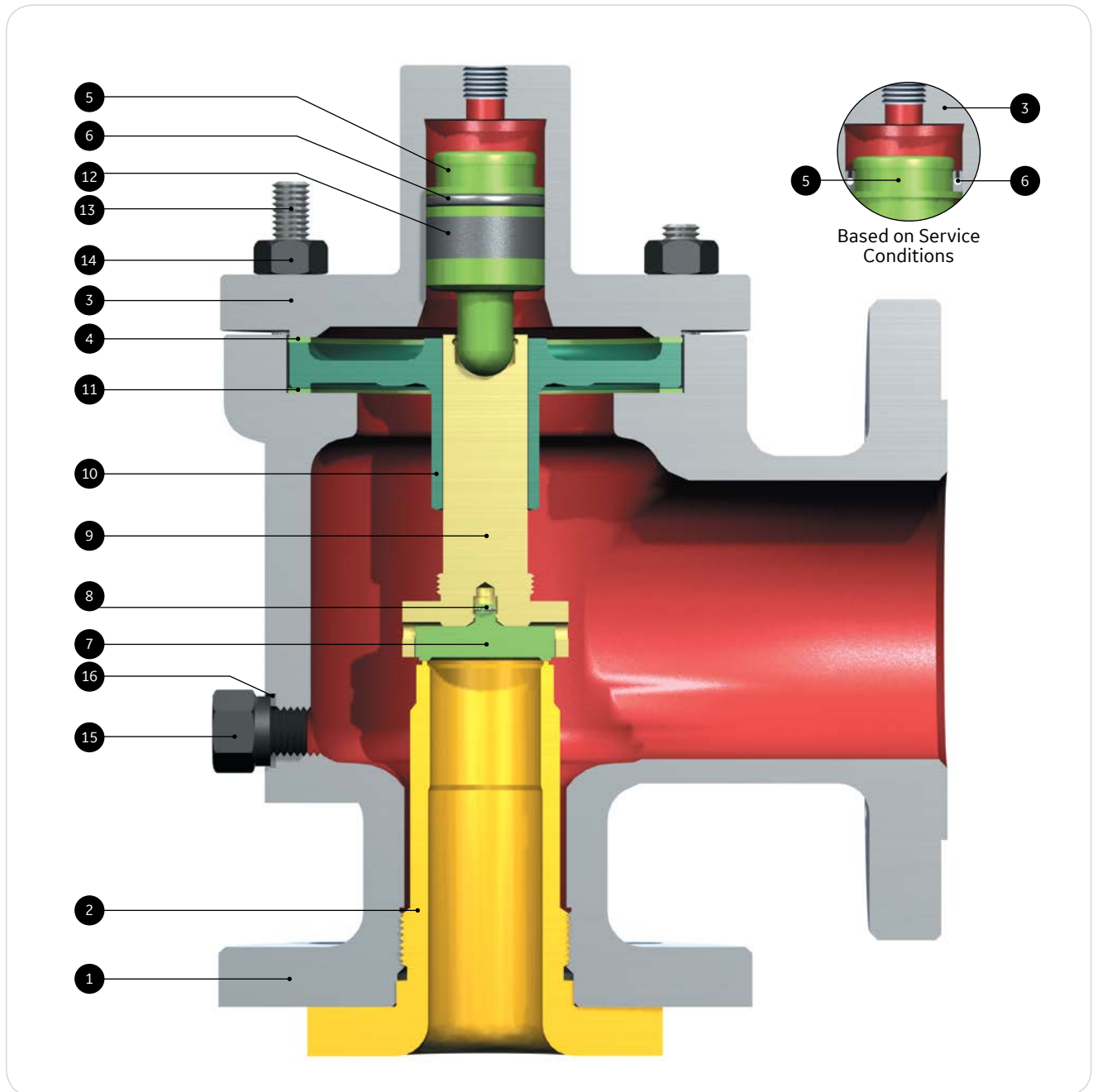

Main Valve Materials

2900 Conventional Type Main Valve (Metal Seat)

Standard Material for 2900 Main Valve D-U Orifices (-00)		
Ref. No.	Nomenclature	Standard Material (-CC)
1	Base	
	2905-2918	ASME SA216 Grade WCC CS
	2920-2928	ASME SA217 Grade WC6 AS
1A	Base Plug (Not Shown)	
	2905-2918	Carbon Steel
	2920-2928	316 Stainless Steel
2	Nozzle	316 Stainless Steel
3	Coverplate	ASME SA351 Grade CF8M St. St.
4	Coverplate Gasket	Soft Iron
5	Main Valve Piston	316 Stainless Steel
6	Main Valve Piston O-ring ¹	Select
7	Disc	
	Metal Seat	316 Stainless Steel
	Thermodisc (Optional)	616 Stainless Steel
8	Disc Retainer	Inconel X-750
9	Disc Holder	316 Stainless Steel
10	Guide	316 Stainless Steel
11	Guide Gasket	Soft Iron
12	Guide Ring(s)	Teflon
13	Stud (Base)	B7 Alloy Steel
14	Nut (Base)	2H Carbon Steel
15	Plug Adaptor	316 Stainless Steel
16	Plug Adaptor Gasket	Soft Iron
	Pilot Mount Bracket	Carbon Steel
	Lifting Eye Bolt	Carbon Steel
	Sensing Ring (Optional)	316 Stainless Steel
	Sensing Tube (Optional)	316 Stainless Steel
	Vent Adaptor (Optional)	316 Stainless Steel
	Heat Exchanger (Optional)	316 Stainless Steel
	39PV & 39MV Pilot Material	Material Option - CC2

Notes:

1. When main valve is equipped with O-ring seat, O-ring for seat and piston shall be of the same material and durometer. When Teflon material is selected, piston shall be equipped with a Teflon energized seal instead of an O-ring.
2. Refer Page no. 2900.33, 2900.44 & 2900.45.

Standard Material for 2900 Main Valve V&W Orifices (-00)		
Ref. No.	Nomenclature	Standard Material (-CC)
1	Base	
	2905-2910	ASME SA216 Grade WCC CS
	2920	ASME SA217 Grade WC6 AS
1A	Base Plug (Not Shown)	
	2905-2910	Carbon Steel
	2920	316 Stainless Steel
2	Nozzle	316 Stainless Steel
3	Coverplate	ASME SA351 Grade CF8M St. St.
4	Coverplate Gasket	Soft Iron
5	Main Valve Piston	316 Stainless Steel
6	Main Valve Piston O-ring ¹	Select
7	Disc	
	Metal Seat	316 Stainless Steel
	Thermodisc (Optional)	Nitronic - 60
8A	Disc Retainer Screws	316 Stainless Steel
8B	Disc Retainer Lockwasher	316 Stainless Steel
9	Disc Holder	
	2905-2910	316 Stainless Steel
	2920	316 St. St. (Glide-Alloy Coated)
10	Guide	
	2905-2910	410 Stainless Steel
	2920	316 St. St. (Glide-Alloy Coated)
11	Guide Gasket	Soft Iron
12	Guide Ring(s)	Teflon
13	Stud (Base)	B7 Alloy Steel
14	Nut (Base)	2H Carbon Steel
15	Plug Adaptor	316 Stainless Steel
16	Plug Adaptor Gasket	Soft Iron
24	Guide Rings (Guide)	Teflon
	Pilot Mount Bracket	Carbon Steel
	Lifting Eye Bolt	Carbon Steel
	Sensing Ring (Optional)	316 Stainless Steel
	Sensing Tube (Optional)	316 Stainless Steel
	Vent Adaptor (Optional)	316 Stainless Steel
	Heat Exchanger (Optional)	316 Stainless Steel
	39PV & 39MV Pilot Material	Material Option - CC2

Main Valve Materials

2900 Bellows Type Main Valve

A bellows option is available on the 2900 MPV series. Its primary use is to isolate and protect the guiding surfaces between the disc holder and guide from particulates or a corrosive media. It can also be used when the temperature on superimposed or built-up backpressure is less than -40°F (-40.0°C) or greater than 505°F (262.8°C). In this event, a factory engineer should be consulted to review the application to determine if the bellows option is a suitable solution.

The bellows is not required for variable or built-up backpressure on a 2900 MPV series as it is on a 1900 safety relief valve. For backpressure operational performance, review the Applications Table on page 2900.9.

Main Valve - Bellows Type (D-U Orifices)

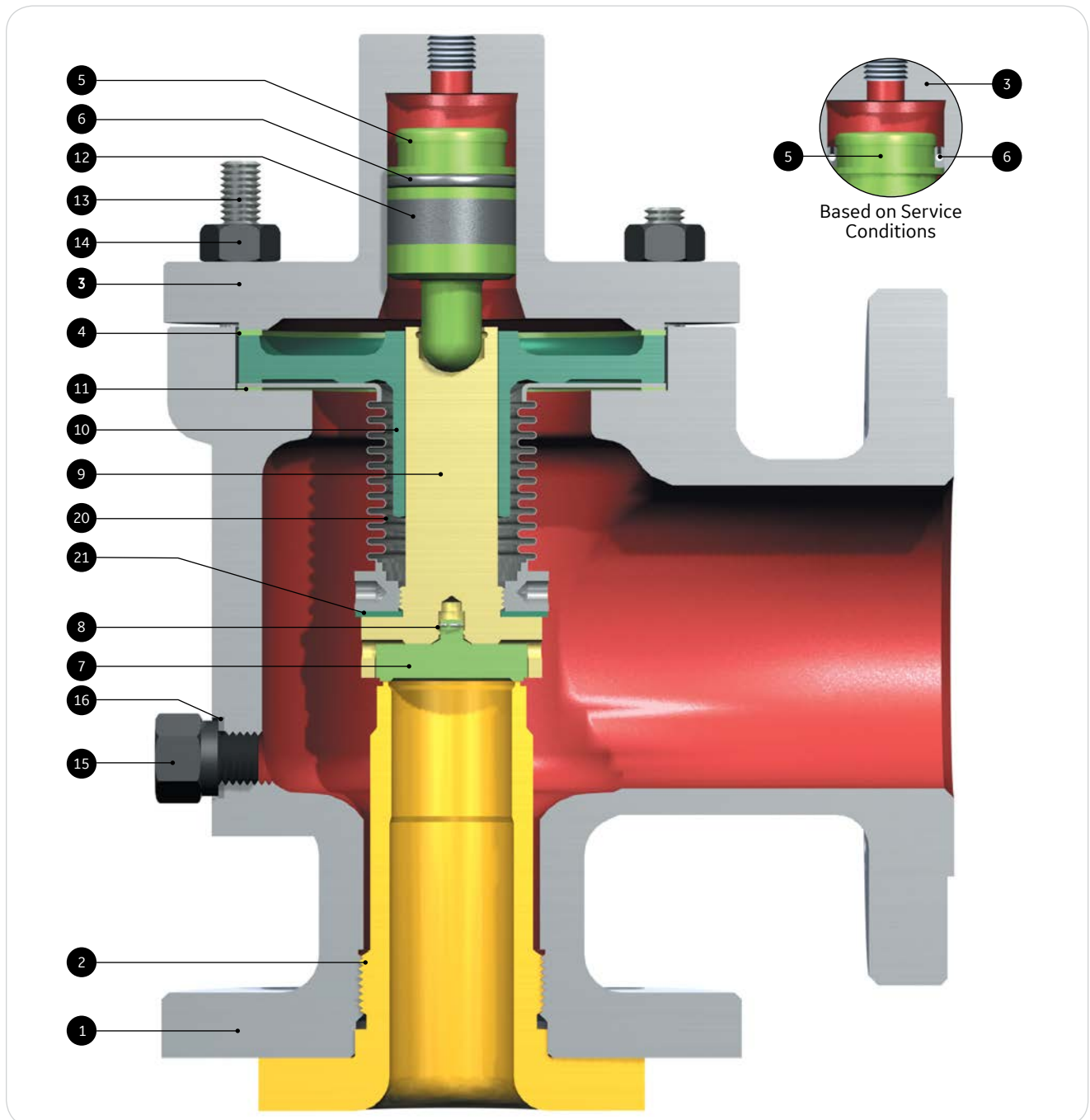

Main Valve Materials

2900 Bellows Type Main Valve

Bellows Material for 2900 Main Valve D-U Orifices (-30)		
Ref. No.	Nomenclature	Bellows Material (-CC)
1	Base	
	2905-2918	ASME SA216 Grade WCC CS
	2920-2928	ASME SA217 Grade WC6 AS
1A	Base Plug	
	2905-2918	Carbon Steel
	2920-2928	316 Stainless Steel
2	Nozzle	316 Stainless Steel
3	Coverplate	ASME SA351 Grade CF8M St. St.
4	Coverplate Gasket	Soft Iron
5	Main Valve Piston	316 Stainless Steel
6	Main Valve Piston O-ring ¹	Select
7	Disc	
	Metal Seat	316 Stainless Steel
	Thermodisc (Optional)	616 Stainless Steel
8	Disc Retainer	Inconel X-750
9	Disc Holder	316 Stainless Steel
10	Guide	316 Stainless Steel
11	Guide Gasket	Soft Iron
12	Guide Ring(s)	Teflon
13	Stud (Base)	B7 Alloy Steel
14	Nut (Base)	2H Carbon Steel
15	Plug Adaptor	316 Stainless Steel
16	Plug Adaptor Gasket	Soft Iron
20	Bellows Assembly	
	Bellows	Inconel 625 LCF
	Bellows Nut	316L Stainless Steel
	Bellows Flange	316L Stainless Steel
21	Bellows Gasket	Soft Iron
	Pilot Mount Bracket	Carbon Steel
	Lifting Eye Bolt	Carbon Steel
	Sensing Ring (Optional)	316 Stainless Steel
	Sensing Tube (Optional)	316 Stainless Steel
	Vent Adaptor (Optional)	316 Stainless Steel
	Heat Exchanger (Optional)	316 Stainless Steel
	39PV & 39MV Pilot Material	Material Option - CC2

Notes:

- When main valve is equipped with O-ring seat, O-ring for seat and piston shall be of the same material and durometer. When Teflon material is selected, piston shall be equipped with a Teflon energized seal instead of an O-ring.
- Refer Page no. 2900.33, 2900.44 & 2900.45.

Bellows Material for 2900 Main Valve V&W Orifices (-30)		
Ref. No.	Nomenclature	Bellows Material (-CC)
1	Base	
	2905-2910	ASME SA216 Grade WCC CS
	2920	ASME SA217 Grade WC6 AS
1A	Base Plug	
	2905-291	Carbon Steel
	2920	316 Stainless Steel
2	Nozzle	316 Stainless Steel
3	Coverplate	ASME SA351 Grade CF8M St. St.
4	Coverplate Gasket	Soft Iron
5	Main Valve Piston	316 Stainless Steel
6	Main Valve Piston O-ring ¹	Select
7	Disc	
	Metal Seat	316 Stainless Steel
	Thermodisc (Optional)	Nitronic - 60
8	Disc Retainer	
8	Disc Retainer Screws	316 Stainless Steel
8A	Disc Retainer Lockwasher	316 Stainless Steel
9	Disc Holder	
	2905-2910	316 Stainless Steel
	2920	316 Stainless Steel (Glide-Aloy Coated)
10	Guide	
	2905-2910	410 Stainless Steel
	2920	316 Stainless Steel (Glide-Aloy Coated)
11	Guide Gasket	Soft Iron
12	Guide Ring(s)	Teflon
13	Stud (Base)	B7 Alloy Steel
14	Nut (Base)	2H Carbon Steel
15	Plug Adaptor	316 Stainless Steel
16	Plug Adaptor Gasket	Soft Iron
20	Bellows Assembly	
	Bellows	Inconel 625 LCF
	Bellows Nut	316L Stainless Steel
	Bellows Flange	316L Stainless Steel
21	Bellows Gasket	Soft Iron
22	Bellows Bolts	316 Stainless Steel
23	Bellows Bolts Lock Washers	316 Stainless Steel
24	Guide Rings (Guide)	Teflon
	Pilot Mount Bracket	Carbon Steel
	Lifting Eye Bolt	Carbon Steel
	Sensing Ring (Optional)	316 Stainless Steel
	Sensing Tube (Optional)	316 Stainless Steel
	Vent Adaptor (Optional)	316 Stainless Steel
	Heat Exchanger (Optional)	316 Stainless Steel
	39PV & 39MV Pilot Material	Material Option - CC2

Main Valve Materials

2900 Series Valve Soft Seats (DA)

The Double Seal Soft Seat

The double seal design incorporates the merits of both a soft seat and a metal seat design valve. The 45° metal seat provides the load bearing surface to transmit piston pressure force, while the slotted O-ring retainer allows the O-ring to be pressurized and accomplish the primary sealing function. For pressure/temperature ratings of the seal, refer to Soft Goods Selection beginning on page 2900.29.

BHGE's O-ring seat seal valves are bubble tight at 98 percent. They provide positive closure for continuous, trouble-free service and complete valve tightness after numerous "pops".

Notes:

The Consolidated 2900 series valve's O-ring design features a secondary metal-to-metal seat which becomes effective if O-ring integrity is lost due to external fire or other causes. The retainer is lapped to the nozzle at assembly assuring seat tightness.

2900 Conventional Type Main Valve - Soft Seat

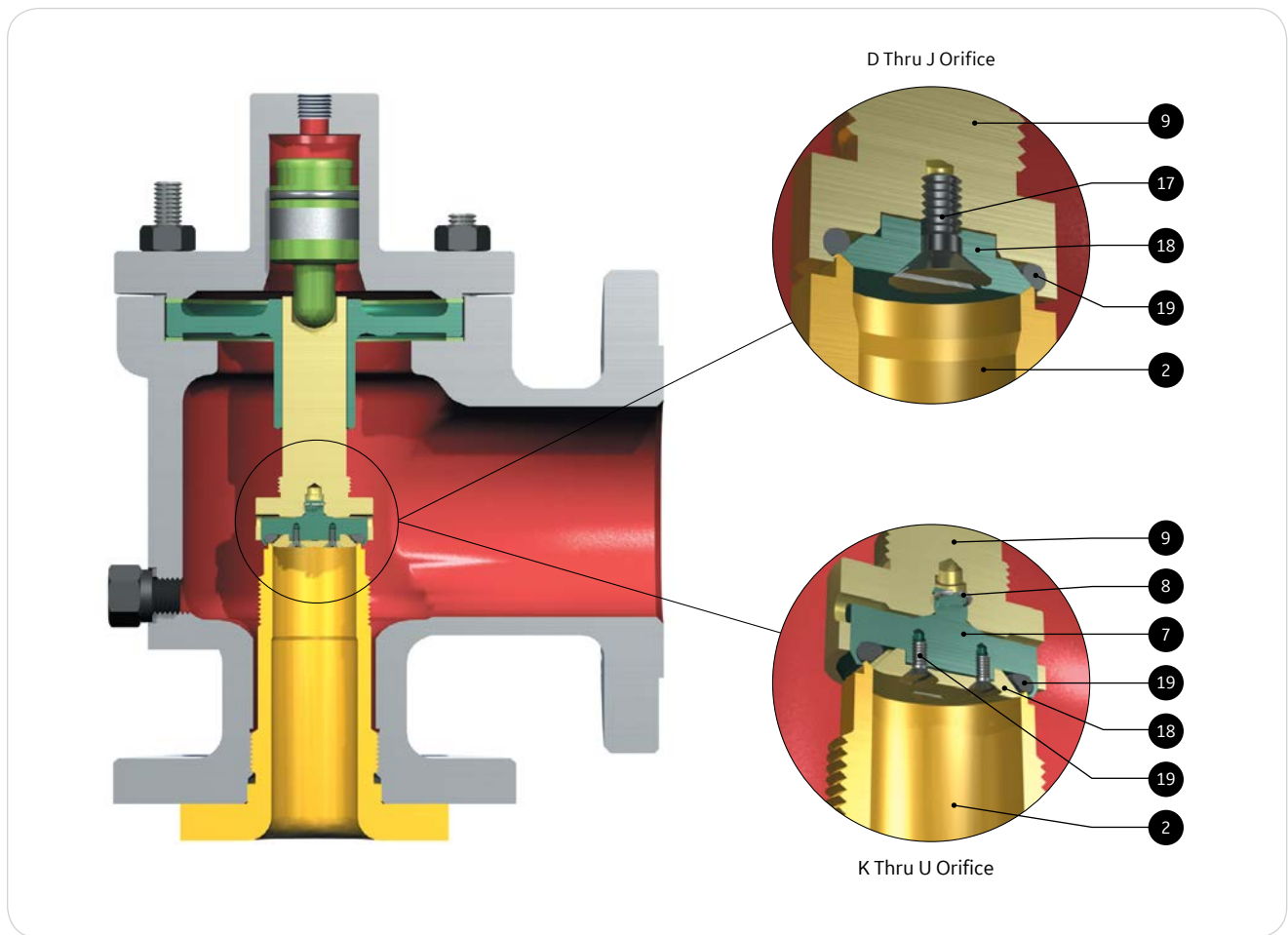

Main Valve Materials

2900 Series Valve Soft Seats (DA)

Standard Material for 2900 Main Valve - Soft Seat D-U Orifices (-CC)			
Ref. No.	Nomenclature	Material (-CC)	
		Conventional Valve Material (-00)	Bellows Valve Material (-30)
1	Base		
	2905-2918	ASME SA216 Grade WCC Carbon Steel	ASME SA216 Grade WCC Carbon Steel
	2920-2928	ASME SA217 Grade WC6 Alloy Steel	ASME SA217 Grade WC6 Alloy Steel
1A	Base Plug		
	2905-2918	Carbon Steel	Carbon Steel
	2920-2928	316 Stainless Steel	316 Stainless Steel
2	Nozzle	316 Stainless Steel	316 Stainless Steel
3	Coverplate	ASME SA351 Grade CF8M Stainless Steel	ASME SA351 Grade CF8M Stainless Steel
4	Coverplate Gasket	Soft Iron	Soft Iron
5	Main Valve Piston	316 Stainless Steel	316 Stainless Steel
6	Main Valve Piston O-ring ¹	Select	Select
7	Disc (K-U)	316 Stainless Steel	316 Stainless Steel
8	Disc Retainer (K-U)	Inconel X-750	Inconel X-750
9	Disc Holder		
	(D-J Orifices) ³	316 Stainless Steel	316 Stainless Steel
	(K-U Orifice)	316 Stainless Steel	316 Stainless Steel
10	Guide	316 Stainless Steel	316 Stainless Steel
11	Guide Gasket	Soft Iron	Soft Iron
12	Guide Ring(s)	Teflon	Teflon
13	Stud (Base)	B7 Alloy Steel	B7 Alloy Steel
14	Nut (Base)	2H Carbon Steel	2H Carbon Steel
15	Plug Adaptor	316 Stainless Steel	316 Stainless Steel
16	Plug Adaptor Gasket	Soft Iron	Soft Iron
17	O-ring Retainer Lock Screw ²	316 Stainless Steel	316 Stainless Steel
18	O-ring Retainer ²	316 Stainless Steel	316 Stainless Steel
19	O-ring Seat Seal ¹	Select	Select
20	Bellows Assembly		
	Bellows	N/A	Inconel 625 LCF
	Bellows Nut	N/A	316L Stainless Steel
	Bellows Flange	N/A	316L Stainless Steel
21	Bellows Gasket	N/A	Soft Iron
	Pilot Mount Bracket	Carbon Steel	Carbon Steel
	Lifting Eye Bolt	Carbon Steel	Carbon Steel
	Sensing Ring (Optional)	316 Stainless Steel	316 Stainless Steel
	Sensing Tube (Optional)	316 Stainless Steel	316 Stainless Steel
	Vent Adaptor (Optional)	316 Stainless Steel	316 Stainless Steel
	Heat Exchanger (Optional)	316 Stainless Steel	316 Stainless Steel
	39PV & 39MV Pilot Material	Material Option - CC4	Material Option - CC4

Notes:

- When main valve is equipped with O-ring seat, O-ring for seat and piston shall be of the same material and durometer. When Teflon material is selected, piston shall be equipped with a Teflon energized seal instead of an O-ring.
- O-ring Retainer material will be Monel for "M" variations and Hastelloy C for "H" variations. The retainer lock screw will be Monel with Nylon locking feature in the "M" variations and Hastelloy C with Nylon locking feature in the "H" variations.
- Disc Holder material for D-J orifice, will be Monel for "M" variations and Hastelloy C for "H" variations.
- Refer Page no. 2900.33, 2900.44 & 2900.45.

Main Valve Materials

How the Double Seal Works

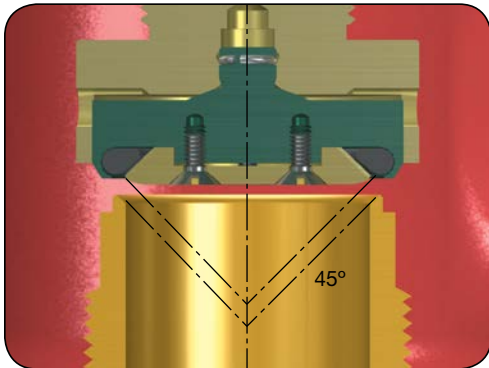

Double Seal

Two unique features distinguish BHGE's Consolidated O-ring seat seal safety valve from other designs. These are the 45° metal-to-metal load-bearing seats and the slotted O-ring retainer.

Three Essentials to Tighter and More Secure Seal

1. Concentric Alignment

The nozzle bore and O-ring retainer are both machined to an angle of 45°. This ensures that as the valve disc opens and closes, the O-ring is aligned concentrically against the lip of the nozzle. Close tolerance between the nozzle and the body, or the body and the disc guide and disc holder, also help to ensure a tight seal when the valve is closed. Accurate alignment, coupled with the load-bearing function of the O-ring retainer, virtually eliminates O-ring abrasion from valve action.

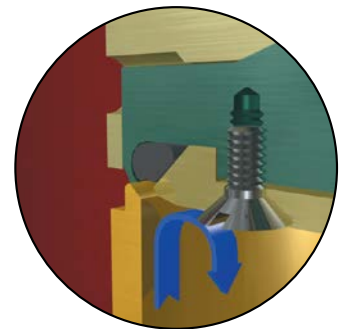

2. Maximum Sealing Force

On the back side of the O-ring retainer there are two small slots. When the valve is closed, process media enters between the machined seat of the nozzle and the O-ring retainer and proceeds up the slots behind the O-ring. This pressure forces the O-ring against the lip of the nozzle and the curved recess of the disc holder. As the pressure within the valve rises to set point, the O-ring is pressed tightly against the nozzle to maintain maximum sealing force until break-away pressure is reached.

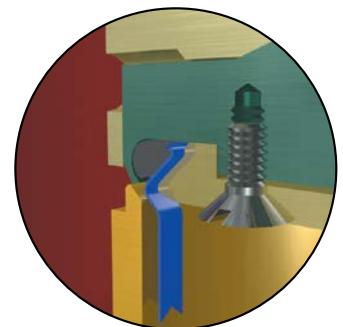

3. O-ring Retention

When the valve opens, the pressure behind the O-ring escapes from the same two slots on the O-ring retainer. This prevents the O-ring from being ejected. Additionally, the O-ring encapsulating retainer prevents the O-ring from being pulled from its setting by the high-velocity, low-pressure discharge inside the upper valve body.

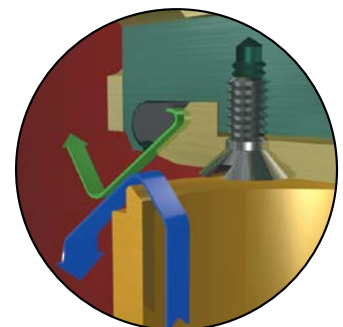

Main Valve Materials

2900 Series Steam Trim (TD) Valves

The Consolidated 2900 Series Valve Steam Trim (TD) option is specifically designed for steam service and organic heat transfer media and is certified to ASME Code Section VIII .

For consistent performance on these medias, specify the “TD” design which utilizes the exclusive Thermodisc™ design.

Designed for use on high-temperature fluids, Thermodisc has more than 40 years of field-proven performance.

A Thermodisc is required for steam service.

The martensitic stainless steel disc construction allows for high strength and toughness. As the set point of the valve is approached, the pressure sealing effect of the Thermodisc helps to tighten the seat, as does the rapid thermal equalization that occurs due to the thin sealing section.

Steam Trim Valve Internals

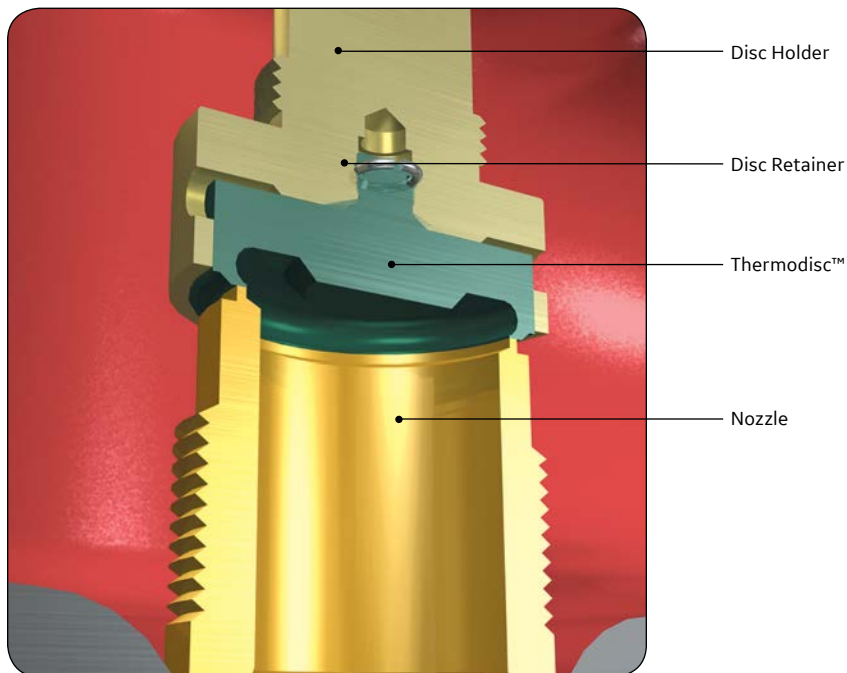

Special Materials

2900 Series Valve Special Material Options

The 2900 series valve requires various material options to satisfy customer needs and API standards. The most common options are listed in this section. For options not listed here, contact the factory. Specify the material construction classification using the construction variations, such as S2 or H4.

Options included are:	Page Number
A1 - Alloy 20 - Wetted Parts when valve is in closed position	19
A2 - Alloy 20 - Internal Parts	19
A4 - Alloy 20 - Complete Valve	19
C1 - LCC Carbon Steel - Ambient Temperatures to -50°F (-45.6°C)	20
D1 - Duplex - Wetted Parts when valve is in closed position	21
D2 - Duplex - Internal Parts	21
D4 - Duplex - Complete Valve	21
H1 - Hastelloy C - Wetted Parts when valve is in closed position	22
H2 - Hastelloy C - Internal Parts	22
H4 - Hastelloy C - Complete Valve	22
L1 - Low Temperature Service (-21 to -75°F) (-29.4 to -59.4°C)	23
L2 - Low Temperature Service (-76 to -150°F) (-60 to -101.1°C)	23
L3 - Low Temperature Service (-151 to -450°F) (-101.7 to -267.8°C)	23
M1 - Monel - Wetted Parts when valve is in closed position	24
MB - (M1 1/2) - Wetted Parts when valve is in closed position plus disc holder	24
M2 - Monel - Internal Parts	24
M4 - Monel - Complete Valve	24
S2 - Stainless Steel - Internal Parts	25
S4 - Stainless Steel - Complete Valve	26
SG - Sour Gas Service	27
T1 - High Temperature Service - (1001°F to 1200°F) (538.3°C to 648.9°C)	28

Many other special options are available not necessarily of a material nature. These include, but are not limited to, special facings on connections or special connections. Contact the factory for special requirements.

Special Materials

Alloy 20

Corrosive Service, Alloy Materials ^{1,2}			
Component	Construction Variation		
	A1	A2	A4
Common Components (-00 & -30)			
Base: 2905-2918	ASME SA216 Grade WCC CS	ASME SA216 Grade WCC CS	ASME SA351 Grade CN7M AS
Base: 2920-2928	ASME SA217 Grade WC6 AS	ASME SA217 Grade WC6 AS	ASME SA351 Grade CN7M AS
Base Plug: 2905-2918	Carbon Steel	Carbon Steel	Alloy 20
Base Plug: 2920-2928	316 Stainless Steel	316 Stainless Steel	Alloy 20
Nozzle	Alloy 20	Alloy 20	Alloy 20
Coverplate	ASME SA351 Grade CN7M AS	ASME SA351 Grade CN7M AS	ASME SA351 Grade CN7M AS
Main Valve Piston	Alloy 20	Alloy 20	Alloy 20
Main Valve Piston O-ring ³	Select	Select	Select
Disc: Metal Seat	Alloy 20	Alloy 20	Alloy 20
Disc: Thermodisc (Optional)	Inconel X-750	Inconel X-750	Inconel X-750
Disc Retainer	Inconel X-750	Inconel X-750	Inconel X-750
Disc Holder	316 Stainless Steel	Alloy 20	Alloy 20
Guide Gasket	Soft Iron	Monel	Monel
Guide Ring(s)	Teflon	Teflon	Teflon
Stud (Base)	B7 Alloy Steel	B7 Alloy Steel	ASTM B473 UNS N08020 (Alloy 20)
Nut (Base)	2H Carbon Steel	2H Carbon Steel	ASTM B473 UNS N08020 (Alloy 20)
Plug Adaptor	316 Stainless Steel	Alloy 20	Alloy 20
Plug Adaptor Gasket	Soft Iron	Monel	Monel
Pilot Mount Bracket	Carbon Steel	Carbon Steel	316 Stainless Steel
Lifting Eye Bolt	Carbon Steel	Carbon Steel	316 Stainless Steel
Sensing Ring (Optional)	Alloy 20	Alloy 20	Alloy 20
Sensing Tube (Optional)	Alloy 20	Alloy 20	Alloy 20
Vent Adaptor (Optional)	316 Stainless Steel	Alloy 20	Alloy 20
Heat Exchanger (Optional)	Alloy 20	Alloy 20	Alloy 20
39PV & 39MV Pilot Material	Material Option - A1 ⁴	Material Option - A1 ⁴	Material Option - A4 ⁴
Conventional (Standard) Components (-00)			
Coverplate Gasket	Soft Iron	Monel	Monel
Guide	316 Stainless Steel	Alloy 20	Alloy 20
Bellows Components (-30)			
Coverplate Gasket	Soft Iron	Soft Iron	Monel
Guide	316 Stainless Steel	316 Stainless Steel	Alloy 20
Bellows Assembly			
Bellows	Inconel 625 LCF	Inconel 625 LCF	Inconel 625 LCF
Bellows Nut, Bellows Flange	316L Stainless Steel	316L Stainless Steel	316L Stainless Steel
Bellows Gasket	Soft Iron	Monel	Monel

Notes:

1. The materials in red denote variation from standard material construction.
2. To specify valves, add material designation to the valve type, 2910L/A4 or 2910-30L/A4.
3. When main valve is equipped with O-ring seat, O-ring for seat and piston shall be of the same material and durometer. When Teflon material is selected, piston shall be equipped with a Teflon energized seal instead of an O-ring.
4. Refer Page no. 2900.35, 2900.46 & 2900.54.

Special Materials

Low Temperatures (C1)

Special Materials for Low Ambient Temperatures [to -50°F (-45.6°C)] ^{1,2}	
Component	Construction Variation - LCC Carbon Steel
	C1 ³
Common Components (-00 & -30)	
Base: 2905-2918	ASME SA352 Grade LCC Carbon Steel
Base Plug: 2905-2918	316 Stainless Steel
Nozzle	316 Stainless Steel
Coverplate	ASME SA351 Grade CF8M Stainless Steel
Coverplate Gasket	Soft Iron
Main Valve Piston	316 Stainless Steel
Main Valve Piston O-ring ⁴	Select
Disc: Metal Seat	316 Stainless Steel
Disc: Thermodisc (Optional)	616 Stainless Steel
Disc Retainer	Inconel X-750
Disc Holder	316 Stainless Steel
Guide	316 Stainless Steel
Guide Gasket	Soft Iron
Guide Ring(s)	Teflon
Stud (Base)	ASME SA193 Grade B8M Stainless Steel
Nut (Base)	ASME SA194 Grade 8M Stainless Steel
Plug Adaptor	316 Stainless Steel
Plug Adaptor Gasket	Soft Iron
Pilot Mount Bracket	316 Stainless Steel
Lifting Eye Bolt	316 Stainless Steel
Sensing Ring (Optional)	316 Stainless Steel
Sensing Tube (Optional)	316 Stainless Steel
Vent Adaptor (Optional)	316 Stainless Steel
Heat Exchanger (Optional)	316 Stainless Steel
39PV & 39MV Pilot Material	Material Option - CC ⁵
Bellows Components (-30)	
Bellows Assembly	
Bellows	Inconel 625 LCF
Bellows Nut	316L Stainless Steel
Bellows Flange	316L Stainless Steel
Bellows Gasket	Soft Iron

Notes:

1. The materials in red denote variation from standard material construction.
2. Material substitution for standard valve configuration. Not for low temperature fluid service. For use primarily by Canada. In low ambient temperature environments [to -50°F (-45.6°C)]. Media temperature may impact valve temperature. Consult factory for assistance.
3. To specify valves, add material designation to the valve type, 2910L/C1 or 2910-30L/C1.
4. When main valve is equipped with O-ring seat, O-ring for seat and piston shall be of the same material and durometer. When Teflon material is selected, piston shall be equipped with a Teflon energized seal instead of an O-ring.
5. Refer Page no. 2900.33, 2900.44 & 2900.45.

Special Materials

Duplex

Corrosive Service, Duplex Materials ^{1,2,3}			
Component	Construction Variation		
	D1	D2	D4
Common Components (-00 & -30)			
Base: 2905-2918	ASME SA216 Grade WCC CS	ASME SA216 Grade WCC CS	ASME SA995 Grade CE8MN4
Base: 2920-2928	ASME SA217 Grade WC6 AS	ASME SA217 Grade WC6 AS	ASME SA995 Grade CE8MN4
Base Plug: 2905-2918	Carbon Steel	Carbon Steel	Duplex
Base Plug: 2920-2928	316 Stainless Steel	316 Stainless Steel	Duplex
Nozzle, Main Valve Piston	Duplex	Duplex	Duplex
Coverplate	ASME SA995 Grade CE8MN4	ASME SA995 Grade CE8MN4	ASME SA995 Grade CE8MN4
Main Valve Piston O-ring ⁵	Select	Select	Select
Disc: Metal Seat	Duplex	Duplex	Duplex
Disc: Thermodisc (Optional)	Inconel X-750	Inconel X-750	Inconel X-750
Disc Retainer	Inconel X-750	Inconel X-750	Inconel X-750
Disc Holder	316 Stainless Steel	Duplex	Duplex
Guide	316 Stainless Steel	Duplex	Duplex
Guide Gasket	Soft Iron	Monel	Monel
Guide Ring(s)	Teflon	Teflon	Teflon
Stud (Base)	B7 Alloy Steel	B7 Alloy Steel	ASME SA193 B8M Stainless Steel
Nut (Base)	2H Carbon Steel	2H Carbon Steel	ASME SA194 8M Stainless Steel
Plug Adaptor	316 Stainless Steel	Duplex	Duplex
Plug Adaptor Gasket	Soft Iron	Monel	Monel
Sensing Ring (Optional)	Duplex	Duplex	Duplex
Sensing Tube (Optional)	Duplex	Duplex	Duplex
Vent Adaptor (Optional)	316 Stainless Steel	316 Stainless Steel	Duplex
Heat Exchanger (Optional)	Duplex	Duplex	Duplex
39PV & 39MV Pilot Material	Material Option - D16	Material Option - D16	Material Option - D46
Standard (Conventional) Components (-00)			
Coverplate Gasket	Soft Iron	Monel	Monel
Pilot Mount Bracket	Carbon Steel	Carbon Steel	316 Stainless Steel
Lifting Eye Bolt	Carbon Steel	Carbon Steel	316 Stainless Steel
Bellows Components (-30)			
Coverplate Gasket	Soft Iron	Soft Iron	Monel
Pilot Mount Bracket	Carbon Steel	Carbon Steel	Carbon Steel
Lifting Eye Bolt	Carbon Steel	Carbon Steel	Carbon Steel
Bellows Assembly			
Bellows	Inconel 625 LCF	Inconel 625 LCF	Inconel 625
Bellows Nut, Bellows Flange	316L Stainless Steel	316L Stainless Steel	Inconel 625
Bellows Gasket	Soft Iron	Monel	Monel

Notes:

- The materials in red denote variation from standard material construction.
- To specify valves, add material designation to the valve type, 2910L/D4 or 2910-30L/D4.
- Parts made from castings shall be constructed from ASME SA995 Grade CE8MN Duplex. Parts made from barstock shall be constructed from ASME SA479 UNS 31803 Duplex.
- (UNS J93345.)
- When main valve is equipped with O-ring seat, O-ring for seat and piston shall be of the same material and durometer. When Teflon material is selected, piston shall be equipped with a Teflon energized seal instead of an O-ring.
- Refer Page no. 2900.36, 2900.47 & 2900.55.

Special Materials

Hastelloy™ C

Corrosive Service, Hastelloy Materials ^{1,2}			
Component	Construction Variation		
	H1	H2	H4
Common Components (-00 & -30)			
Base: 2905-2918	ASME SA216 Grade WCC CS	ASME SA216 Grade WCC CS	ASME SA494 CW12MW Nickel Alloy
Base: 2920-2928	ASME SA217 Grade WC6 AS	ASME SA217 Grade WC6 AS	ASME SA494 CW12MW Nickel Alloy
Base Plug: 2905-2918	Carbon Steel	Carbon Steel	Hastelloy C
Base Plug: 2920-2928	316 Stainless Steel	316 Stainless Steel	Hastelloy C
Nozzle	Hastelloy C	Hastelloy C	Hastelloy C
Coverplate	ASME SA494 CW12MW Nickel Alloy	ASME SA494 CW12MW Nickel Alloy	ASME SA494 CW12MW Nickel Alloy
Main Valve Piston	Hastelloy C	Hastelloy C	Hastelloy C
Main Valve Piston O-ring ³	Select	Select	Select
Disc: Metal Seat	Hastelloy C	Hastelloy C	Hastelloy C
Disc: Thermodisc (Optional)	Inconel X-750	Inconel X-750	Inconel X-750
Disc Retainer	Inconel X-750	Inconel X-750	Inconel X-750
Disc Holder	316 Stainless Steel	Hastelloy C	Hastelloy C
Guide	316 Stainless Steel	Hastelloy C	Hastelloy C
Guide Gasket	Soft Iron	Monel	Monel
Guide Ring(s)	Teflon	Teflon	Teflon
Stud (Base)	B7 Alloy Steel	B7 Alloy Steel	Hastelloy C
Nut (Base)	2H Carbon Steel	2H Carbon Steel	Hastelloy C
Plug Adaptor	316 Stainless Steel	Hastelloy C	Hastelloy C
Plug Adaptor Gasket	Soft Iron	Monel	Monel
Pilot Mount Bracket	Carbon Steel	Carbon Steel	316 Stainless Steel
Lifting Eye Bolt	Carbon Steel	Carbon Steel	316 Stainless Steel
Sensing Ring (Optional)	Hastelloy C	Hastelloy C	Hastelloy C
Sensing Tube (Optional)	Hastelloy C	Hastelloy C	Hastelloy C
Vent Adaptor (Optional)	316 Stainless Steel	Hastelloy C	Hastelloy C
Heat Exchanger (Optional)	Hastelloy C	Hastelloy C	Hastelloy C
39PV & 39MV Pilot Material	Material Option - H1 ⁴	Material Option - H1 ⁴	Material Option - H4 ⁴
Standard (Conventional) Components (-00)			
Coverplate Gasket	Soft Iron	Monel	Monel
Bellows Components (-30)			
Coverplate Gasket	Soft Iron	Soft Iron	Monel
Bellows Assembly			
Bellows	Inconel 625 LCF	Inconel 625 LCF	Monel
Bellows Nut, Bellows Flange	316L Stainless Steel	316L Stainless Steel	Monel
Bellows Gasket	Soft Iron	Monel	Monel

Notes:

1. The materials in red denote variation from standard material construction.
2. To specify valves, add material designation to the valve type, 2910L/H4 or 2910-30L/H4.
3. When main valve is equipped with O-ring seat, O-ring for seat and piston shall be of the same material and durometer. When Teflon material is selected, piston shall be equipped with a Teflon energized seal instead of an O-ring.
4. Refer Page no. 2900.37, 2900.48 & 2900.56.

Special Materials

Low Temperatures

Special Materials for Low Process Fluid Temperature ^{1,2}			
Component	Construction Variation- Low Temperature Service		
	-21 to -75°F (-29 to -59°C)	-76 to -150°F (-60 to -101°C)	-151 to -450°F (-102 to -268°C)
	L13	L2	L3
Common Components (-00 & -30)			
Base: 2905-2918	ASME SA351 Grade CF8M St. St.	ASME SA351 Grade CF8M St. St.	ASME SA351 Grade CF8M St. St.
Base: 2920-2928	ASME SA351 Grade CF8M St. St.	ASME SA351 Grade CF8M St. St.	ASME SA351 Grade CF8M St. St.
Base Plug: 2905-2918	316 Stainless Steel	316 Stainless Steel	316 Stainless Steel
Base Plug: 2920-2928	316 Stainless Steel	316 Stainless Steel	316 Stainless Steel
Nozzle	316 Stainless Steel	316 Stainless Steel	316 Stainless Steel
Coverplate	ASME SA351 Grade CF8M St. St.	ASME SA351 Grade CF8M St. St.	ASME SA351 Grade CF8M St. St.
Coverplate Gasket	Monel	Monel	Monel
Main Valve Piston	316 Stainless Steel	316 Stainless Steel	316 Stainless Steel
Main Valve Piston O-ring ⁴	Select	Select	Select
Disc: Metal Seat	316 Stainless Steel	316 Stainless Steel	316 Stainless Steel
Disc: Thermodisc (Optional)	Inconel X-750	Inconel X-750	Inconel X-750
Disc Retainer	Inconel X-750	Inconel X-750	Inconel X-750
Disc Holder	316 Stainless Steel	316 Stainless Steel	316 Stainless Steel
Guide	316 Stainless Steel	316 Stainless Steel	316 Stainless Steel
Guide Gasket	Monel	Monel	Monel
Guide Ring(s)	Teflon	Teflon	Teflon
Stud (Base)	ASME SA193 Grade B8M St. St.	ASME SA193 Grade B8M St. St.	ASME SA193 Grade B8M St. St.
Nut (Base)	ASME SA194 8M Stainless Steel	ASME SA194 8M Stainless Steel	ASME SA194 8M Stainless Steel
Plug Adaptor	316 Stainless Steel	316 Stainless Steel	316 Stainless Steel
Plug Adaptor Gasket	Monel	Monel	Monel
Pilot Mount Bracket	Carbon Steel	Carbon Steel	316 Stainless Steel
Lifting Eye Bolt	Carbon Steel	Carbon Steel	316 Stainless Steel
Sensing Ring (Optional)	316 Stainless Steel	316 Stainless Steel	316 Stainless Steel
Sensing Tube (Optional)	316 Stainless Steel	316 Stainless Steel	316 Stainless Steel
Vent Adaptor (Optional)	316 Stainless Steel	316 Stainless Steel	316 Stainless Steel
Heat Exchanger (Optional)	316 Stainless Steel	316 Stainless Steel	316 Stainless Steel
39PV & 39MV Pilot Material	Material Option - CC ⁵	Material Option - CC ⁵	Material Option - CC ⁵
Bellows Components (-30)			
Bellows Assembly			
Bellows	Inconel 625 LCF	Inconel 625 LCF	316L Stainless Steel
Bellows Nut	316L Stainless Steel	316L Stainless Steel	316L Stainless Steel
Bellows Flange	316L Stainless Steel	316L Stainless Steel	316L Stainless Steel
Bellows Gasket	Monel	Monel	Monel

Notes:

1. The materials in red denote variation from standard material construction.
2. To specify valves, add material designation to the valve type, 2910L/L3 or 2910-30L/L3.
3. ASME SA352 LCC Carbon Steel can be substituted for bases down to -50°F (-45.6°C) when requested.
4. When main valve is equipped with O-ring seat, O-ring for seat and piston shall be of the same material and durometer. When Teflon material is selected, piston shall be equipped with a Teflon energized seal instead of an O-ring.
5. Refer Page no. 2900.33, 2900.44 & 2900.45.

Special Materials

Monel®

Corrosive Service, Monel® Materials ^{1,2}				
Component	Construction Variation			
	M1	MB (M 1-1/2)	M2	M4
Common Components (-00 & -30)				
Base: 2905-2918	ASME SA216 Grade WCC CS	ASME SA216 Grade WCC CS	ASME SA216 Grade WCC CS	ASME SA494 Grade M35-1 ³
Base: 2920-2928	ASME SA217 Grade WC6 AS	ASME SA217 Grade WC6 AS	ASME SA217 Grade WC6 AS	ASME SA494 Grade M35-1 ³
Base Plug: 2905-2918	Carbon Steel	Carbon Steel	Carbon Steel	Monel
Base Plug: 2920-2928	316 Stainless Steel	316 Stainless Steel	316 Stainless Steel	Monel
Nozzle	Monel	Monel	Monel	Monel
Coverplate	ASME SA494 Grade M35-1 ³	ASME SA494 Grade M35-1 ³	ASME SA494 Grade M35-1 ³	ASME SA494 Grade M35-1 ³
Main Valve Piston	Monel	Monel	Monel	Monel
Main Valve Piston O-ring ⁴	Select	Select	Select	Select
Disc: Metal Seat	Monel	Monel	Monel	Monel
Disc: Thermodisc (Optional)	Inconel X-750	Inconel X-750	Inconel X-750	Inconel X-750
Disc Retainer	Inconel X-750	Inconel X-750	Inconel X-750	Inconel X-750
Disc Holder	316 Stainless Steel	Monel	Monel	Monel
Guide	316 Stainless Steel	316 Stainless Steel	Monel	Monel
Guide Gasket	Soft Iron	Monel	Monel	Monel
Guide Ring(s)	Teflon	Teflon	Teflon	Teflon
Stud (Base)	B7 Alloy Steel	B7 Alloy Steel	B7 Alloy Steel	Monel K500
Nut (Base)	2H Carbon Steel	2H Carbon Steel	2H Carbon Steel	Monel K500
Plug Adaptor	316 Stainless Steel	316 Stainless Steel	Monel	Monel
Plug Adaptor Gasket	Soft Iron	Monel	Monel	Monel
Pilot Mount Bracket	Carbon Steel	Carbon Steel	Carbon Steel	316 Stainless Steel
Lifting Eye Bolt	Carbon Steel	Carbon Steel	Carbon Steel	316 Stainless Steel
Sensing Ring (Optional)	Monel	Monel	Monel	Monel
Sensing Tube (Optional)	Monel	Monel	Monel	Monel
Vent Adaptor (Optional)	316 Stainless Steel	316 Stainless Steel	Monel	Monel
Heat Exchanger (Optional)	Monel	Monel	Monel	Monel
39PV & 39MV Pilot Material	Material Option - M1 ⁵	Material Option - M1 ⁵	Material Option - M1 ⁵	Material Option - M4 ⁵
Conventional (Standard) Components (-00)				
Coverplate Gasket	Soft Iron	Monel	Monel	Monel
Bellows Components (-30)				
Coverplate Gasket	Soft Iron	Soft Iron	Monel	Monel
Bellows Assembly				
Bellows	Inconel 625 LCF	Inconel 625 LCF	Monel	Monel
Bellows Nut	316L Stainless Steel	316L Stainless Steel	Monel	Monel
Bellows Flange	316L Stainless Steel	316L Stainless Steel	Monel	Monel
Bellows Gasket	Soft Iron	Monel	Monel	Monel

Notes:

1. The materials in red denote variation from standard material construction.
2. To specify valves, add material designation to the valve type, 2910L/M4 or 2910-30L/M4.
3. Nickel Copper Alloy (ASME Code Case 1750-22).
4. When main valve is equipped with O-ring seat, O-ring for seat and piston shall be of the same material and durometer. When Teflon material is selected, piston shall be equipped with a Teflon energized seal instead of an O-ring.
5. Refer Page no. 2900.38, 2900.49 & 2900.57.

Special Materials

Stainless Steel

Corrosive Service, Stainless Steel Materials (D-U Orifices) ^{1,2}		
Component	Construction Variation	
	S2	S4
Common Components (-00 & -30)		
Base: 2905-2918	ASME SA216 Grade WCC CS	ASME SA351 Grade CF8M St. St.
Base: 2920-2928	ASME SA217 Grade WC6 Alloy Steel	ASME SA351 Grade CF8M St. St.
Base Plug: 2905-2918	Carbon Steel	316 Stainless Steel
Base Plug: 2920-2928	316 Stainless Steel	316 Stainless Steel
Nozzle	316 Stainless Steel	316 Stainless Steel
Coverplate	ASME SA351 Grade CF8M St. St.	ASME SA351 Grade CF8M St. St.
Main Valve Piston	316 Stainless Steel	316 Stainless Steel
Main Valve Piston O-ring ³	Select	Select
Disc: Metal Seat	316 Stainless Steel	316 Stainless Steel
Disc: Thermodisc (Optional)	616 Stainless Steel	616 Stainless Steel
Disc Retainer	Inconel X-750	Inconel X-750
Disc Holder	316 Stainless Steel	316 Stainless Steel
Guide	316 Stainless Steel	316 Stainless Steel
Guide Gasket	Monel	Monel
Guide Ring(s)	Teflon	Teflon
Stud (Base)	B7 Alloy Steel	ASME SA193 B8M Stainless Steel
Nut (Base)	2H Carbon Steel	ASME SA194 8M Stainless Steel
Plug Adaptor	316 Stainless Steel	316 Stainless Steel
Plug Adaptor Gasket	Monel	Monel
Pilot Mount Bracket	Carbon Steel	316 Stainless Steel
Lifting Eye Bolt	Carbon Steel	316 Stainless Steel
Sensing Ring (Optional)	316 Stainless Steel	316 Stainless Steel
Sensing Tube (Optional)	316 Stainless Steel	316 Stainless Steel
Vent Adaptor (Optional)	316 Stainless Steel	316 Stainless Steel
Heat Exchanger (Optional)	316 Stainless Steel	316 Stainless Steel
39PV & 39MV Pilot Material	Material Option - CC ⁴	Material Option - CC ⁴
Conventional (Standard) Components (-00)		
Coverplate Gasket	Monel	Monel
Bellows Components (-30)		
Coverplate Gasket	Soft Iron	Monel
Bellows Assembly		
Bellows	Inconel 625 LCF	Inconel 625 LCF
Bellows Nut	316L Stainless Steel	316L Stainless Steel
Bellows Flange	316L Stainless Steel	316L Stainless Steel
Bellows Gasket	Monel	Monel

Notes:

1. The materials in red denote variation from standard material construction.
2. To specify valves, add material designation to the valve type, 2910L/S4 or 2910-30L/S4.
3. When main valve is equipped with O-ring seat, O-ring for seat and piston shall be of the same material and durometer. When Teflon material is selected, piston shall be equipped with a Teflon energized seal instead of an O-ring.
4. Refer Page no. 2900.33, 2900.44 & 2900.45.

Special Materials

Stainless Steel

Corrosive Service, Stainless Steel Materials (V&W Orifices) ^{1,2}		
Component	Construction Variation	
	S2	S4
Common Components (-00 & -30)		
Base: 2905-2910	ASME SA216 Grade WCC Carbon Steel	ASME SA351 Grade CF8M Stainless Steel
Base: 2920	ASME SA217 Grade WC6 Alloy Steel	ASME SA351 Grade CF8M Stainless Steel
Base Plug: 2905-2910	Carbon Steel	316 Stainless Steel
Base Plug: 2920	316 Stainless Steel	316 Stainless Steel
Nozzle	316 Stainless Steel	316 Stainless Steel
Coverplate	ASME SA351 Grade CF8M Stainless Steel	ASME SA351 Grade CF8M Stainless Steel
Main Valve Piston	316 Stainless Steel	316 Stainless Steel
Main Valve Piston O-ring ³	Select	Select
Disc: Metal Seat	316 Stainless Steel	316 Stainless Steel
Disc: Thermomdisc (Optional)	Nitronic - 60	Nitronic - 60
Disc Retainer Screws	316 Stainless Steel	316 Stainless Steel
Disc Retainer Lockwasher	316 Stainless Steel	316 Stainless Steel
Disc Holder: 2905-2910	316 Stainless Steel	316 Stainless Steel
Disc Holder: 2920, Guide: 2920	316 Stainless Steel (Glide-Aloy Coated)	316 Stainless Steel (Glide-Aloy Coated)
Guide: 2905-2910	316 Stainless Steel	316 Stainless Steel
Guide Gasket, Plug Adaptor Gasket	Monel	Monel
Guide Ring(s) (Piston, Guide)	Teflon	Teflon
Stud (Base)	B7 Alloy Steel	B7 Alloy Steel
Nut (Base)	2H Carbon Steel	2H Carbon Steel
Plug Adaptor	316 Stainless Steel	316 Stainless Steel
Pilot Mount Bracket, Lifting Eye Bolt	Carbon Steel	Carbon Steel
Sensing Ring (Optional)	316 Stainless Steel	316 Stainless Steel
Sensing Tube (Optional)	316 Stainless Steel	316 Stainless Steel
Vent Adaptor (Optional)	316 Stainless Steel	316 Stainless Steel
Heat Exchanger (Optional)	316 Stainless Steel	316 Stainless Steel
39PV & 39MV Pilot Material	Material Option - CC ⁴	Material Option - CC ⁴
Conventional (Standard) Components (-00)		
Coverplate Gasket	Monel	Monel
Bellows Components (-30)		
Coverplate Gasket	Soft Iron	Monel
Bellows Assembly		
Bellows	Inconel 625 LCF	Inconel 625 LCF
Bellows Nut, Bellows Flange	316L Stainless Steel	316L Stainless Steel
Bellows Gasket	Monel	Monel
Bellows Bolts, Bellows Bolts Lock Washers	316 Stainless Steel	316 Stainless Steel

Notes:

1. The materials in red denote variation from standard material construction.
2. To specify valves, add material designation to the valve type, 2910L/S4 or 2910-30L/S4.
3. When main valve is equipped with O-ring seat, O-ring for seat and piston shall be of the same material and durometer. When Teflon material is selected, piston shall be equipped with a Teflon energized seal instead of an O-ring.
4. Refer Page no. 2900.33, 2900.44 & 2900.45.

Special Materials

2900 Series Valve Sour Gas Trim (SG)

Material requirements of NACE Standard MR-01-75 are applicable to systems handling sour gas if the total operating pressure of the system is 65 psia (4.48 bara) or greater and if the partial pressure of H₂S in the gas is 0.05 psia (0.003 bara) or greater.

The 2900 series valve standard Material of Construction is satisfactory for applications in which the valve secondary pressure (outlet side) does not exceed 65 psia (50 psig) [4.48 bara (3.45 barg)]. Under valve relieving conditions, 50 psig (3.45 barg) secondary pressure would not normally be exceeded until the valve set pressure exceeds 450 psig (31.03 barg).

The SG (Non-Bellows) and SG (Bellows) material selections comply with NACE MR-01-75.

Specific applications may be referred to the factory for recommendations

Special Material for Sour Gas Service ^{1,2}	
Component	Construction Variation
	SG
Common Components (-00 & -30)	
Base: 2905-2918	ASME SA216 Grade WCC CS
Base: 2920-2928	ASME SA217 Grade WC6 AS
Base Plug: 2905-2918	Carbon Steel
Base Plug: 2920-2928	316 Stainless Steel
Nozzle	316 Stainless Steel
Coverplate	ASME SA351 Grade CF8M St. St.
Coverplate Gasket	Soft Iron
Main Valve Piston	316 Stainless Steel
Main Valve Piston O-ring ³	Select
Disc: Metal Seat	316 Stainless Steel
Disc: Thermodisc (Optional)	Inconel X-750
Disc Retainer	Inconel X-750
Disc Holder	316 Stainless Steel
Guide	316 Stainless Steel
Guide Gasket	Soft Iron
Guide Ring(s)	Teflon
Stud (Base)	B7 Alloy Steel
Nut (Base)	2H Carbon Steel
Plug Adaptor	316 Stainless Steel
Plug Adaptor Gasket	Soft Iron
Pilot Mount Bracket	Carbon Steel
Lifting Eye Bolt	Carbon Steel
Sensing Ring (Optional)	316 Stainless Steel
Sensing Tube (Optional)	316 Stainless Steel
Vent Adaptor (Optional)	316 Stainless Steel
Heat Exchanger (Optional)	316 Stainless Steel
39PV & 39MV Pilot Material	Material Option - SG4
Bellows Components (-30)	
Bellows Assembly	
Bellows	Inconel 625 LCF
Bellows Nut	316L Stainless Steel
Bellows Flange	316L Stainless Steel
Bellows Gasket	Soft Iron

Notes:

1. The materials in red denote variation from standard material construction.
2. To specify valves, add material designation to the valve type, 2910L/SG or 2910-30L/SG.
3. When main valve is equipped with O-ring seat, O-ring for seat and piston shall be of the same material and durometer. When Teflon material is selected, piston shall be equipped with a Teflon energized seal instead of an O-ring.
4. Refer Page no. 2900.39, 2900.50 & 2900.58.

Special Materials

High Temperatures

Special Material for High Temperature Service [(1001 to 1200°F (538.3 to 648.9°C)] ^{1,2}	
Component	Construction Variation - T1
Common Components (-00 & -30)	
Base: 2905-2918	ASME SA351 Grade CF8M Stainless Steel
Base: 2920-2928	ASME SA351 Grade CF8M Stainless Steel
Base Plug: 2905-2918	316 Stainless Steel
Base Plug: 2920-2928	316 Stainless Steel
Nozzle	316 Stainless Steel
Coverplate	ASME SA351 Grade CF8M Stainless Steel
Coverplate Gasket	Monel
Main Valve Piston	316 Stainless Steel
Main Valve Piston O-ring ³	Select
Disc: Metal Seat	316 Stainless Steel
Disc: Thermodisc (Optional)	Inconel X-750
Disc Retainer	Inconel X-750
Disc Holder	316 Stainless Steel (Glide-Aloy Coated)
Guide	316 Stainless Steel
Guide Gasket	Monel
Guide Ring(s)	Teflon
Stud (Base)	ASME SA193 B8M Stainless Steel
Nut (Base)	ASME SA194 8M Stainless Steel
Plug Adaptor	316 Stainless Steel
Plug Adaptor Gasket	Monel
Pilot Mount Bracket	Carbon Steel
Lifting Eye Bolt	Carbon Steel
Sensing Ring (Optional)	316 Stainless Steel
Sensing Tube (Optional)	316 Stainless Steel
Vent Adaptor (Optional)	316 Stainless Steel
Heat Exchanger (Optional)	316 Stainless Steel
39PV & 39MV Pilot Material	Material Option - CC4
Bellows Components (-30)	
Bellows Assembly	
Bellows	Inconel 625 LCF
Bellows Nut	Inconel 625
Bellows Flange	Inconel 625
Bellows Gasket	Monel

Notes:

1. The materials in red denote variation from standard material construction.
2. To specify valves, add material designation to the valve type, 2910L/T1 or 2910-30L/T1.
3. When main valve is equipped with O-ring seat, O-ring for seat and piston shall be of the same material and durometer. When Teflon material is selected, piston shall be equipped with a Teflon energized seal instead of an O-ring.
4. Refer Page no. 2900.33, 2900.44 & 2900.45.

Soft Goods Selection

Soft Goods Selection Chart

2900 Series Valve Soft Goods Selection Chart ⁴				
Component	Description	Service		
		Liquid/Gas ³	Steam	
		15 to 6250 psig (1.03 to 430.92 barg)	15 to 49 psig (1.03 to 3.38 barg)	50 to 3750 psig (3.45 to 258.55 barg)
Main Valve ¹	Seat O-ring Option	Select	ethylene/propylene 90	Teflon [®]
	Piston Spring Seal ²	Teflon [®]	N/A	Teflon [®]
	Piston O-ring ²	Select	ethylene/propylene 90	N/A
	Piston Guide Ring	Teflon [®]	Teflon [®]	Teflon [®]
Pilot Valve	Adjuster Bottom O-ring	Select	ethylene/propylene 90	Teflon [®]
	Adjuster Top O-ring	Select	ethylene/propylene 90	Teflon [®]
	Insert O-ring	Select	ethylene/propylene 90	Teflon [®]
	Base O-ring	Select	ethylene/propylene 90	Teflon [®]
	Piston Spring Seal	Teflon [®]	Teflon [®]	Teflon [®]
	Adjuster Top Spring Seal	Teflon [®]	Teflon [®]	Teflon [®]
	Insert Spring Seal	Teflon [®]	Teflon [®]	Teflon [®]
Modulator	Base O-ring	Select	ethylene/propylene 90	Teflon [®]
	Stop O-ring	Select	ethylene/propylene 90	Teflon [®]
	Seat O-ring	Select	ethylene/propylene 90	Teflon [®]
	Piston Bottom O-ring	Select	ethylene/propylene 90	Teflon [®]
	Piston Bottom Spring Seal	Teflon [®]	Teflon [®]	Teflon [®]
	Piston Top Spring Seal	Teflon [®]	Teflon [®]	Teflon [®]

Notes:

1. When main valve is equipped with O-ring seat, O-rings for seat and piston shall be of the same material and durometer.
2. When Teflon[®] material is selected, piston shall be equipped with a Teflon[®]Z energized seal instead of an O-ring.
3. Select soft good using charts for fluid, pressure and temperature. See selection instructions below.
4. When a Heat Exchanger is required, use the exit temperature of the Heat Exchanger to select the soft goods.
(A standard metal seat is used on the main base with the heat exchanger.)

Soft Goods selection for liquid and gas service is accomplished as follows:

A) Material Selection

- The customer must specify the O-ring material.

B) Main Valve Pressure Limits

- Refer to Table 1 on page 2900.30.
- Locate the valve orifice and select the durometer for the required set pressure.

C) Main Valve Temperature Limits

- Refer to Table 2 on page 2900.30.
- Locate the material and durometer and verify the temperature limits.
- If temperature limits are exceeded, repeat Steps A & B.
- If an O-ring cannot be selected, contact the application engineer.

D) Pilot Valve Pressure and Temperature Limits

- Refer to Table 3 on page 2900.30.
- Locate the service and review the pressure and temperature ranges, then select the material and durometer.

Soft Goods Selection

Pressure and Temperature Limits

Main Valve and Pilot Valve/Modulator

Table 1: Main Valve Pressure Limits

Orifice	Durometer ²										Teflon ³							
	50		70-75 ¹				90				-300 to + 200°F (-184.4 to + 93.3°F)				201 to 505°F (93.9 to 262.8°C)			
	min.	max.	min.		max.		min.		max.		min.		max.		min.		max.	
			psig	barg	psig	barg	psig	barg	psig	barg	psig	barg	psig	barg	psig	barg		
2900 D	N/A	N/A	15	1.03	800	55.16	801	55.23	3750	258.55	2000	137.90	6000	413.69	50	3.45	6250	430.92
2900 E	N/A	N/A	15	1.03	800	55.16	801	55.23	3750	258.55	2000	137.90	6000	413.69	50	3.45	6250	430.92
2900 F	N/A	N/A	15	1.03	800	55.16	801	55.23	3750	258.55	2000	137.90	6000	413.69	50	3.45	6250	430.92
2900 G	N/A	N/A	15	1.03	780	53.78	781	53.85	3750	258.55	1900	131.00	6000	413.69	50	3.45	6250	430.92
2900 H	N/A	N/A	15	1.03	780	53.78	781	53.85	3750	258.55	1900	131.00	3600	248.21	50	3.45	3750	258.55
2900 J	N/A	N/A	15	1.03	780	53.78	781	53.85	3750	258.55	1900	131.00	3600	248.21	50	3.45	3750	258.55
2900 K	N/A	N/A	15	1.03	580	39.99	581	40.06	3750	258.55	1400	96.53	3600	248.21	50	3.45	3750	258.55
2900 L	N/A	N/A	15	1.03	580	39.99	581	40.06	3750	258.55	1400	96.53	2160	148.93	50	3.45	3750	258.55
2900 M	N/A	N/A	15	1.03	580	39.99	581	40.06	2250	155.13	1400	96.53	1440	99.28	50	3.45	2250	155.13
2900 N	N/A	N/A	15	1.03	580	39.99	581	40.06	2250	155.13	1400	96.53	1440	99.28	50	3.45	2250	155.13
2900 P	N/A	N/A	15	1.03	500	34.47	501	34.54	2250	155.13	-	-	-	-	50	3.45	2250	155.13
2900 Q	N/A	N/A	15	1.03	420	28.96	421	29.03	1500	103.42	-	-	-	-	50	3.45	1500	103.42
2900 R	N/A	N/A	15	1.03	420	28.96	421	29.03	1500	103.42	-	-	-	-	50	3.45	1500	103.42
2900 T	N/A	N/A	15	1.03	300	20.68	301	20.75	905	62.40	-	-	-	-	50	3.45	905	62.40
2900 V	N/A	N/A	15	1.03	300	20.68	301	20.75	675	46.54	-	-	-	-	50	3.45	675	46.54
2900 W	N/A	N/A	15	1.03	300	20.68	301	20.75	535	36.89	-	-	-	-	50	3.45	535	36.89

Notes:

1. Maximum set pressure for silicone compounds is 1/2 of the maximum value.
2. When main valve is equipped with O-ring seat, O-rings for seat and piston shall be of the same material and durometer.
3. When Teflon[®] material is selected, piston shall be equipped with a Teflon[®] energized seal instead of an O-ring.

Table 2: Main Valve Temperature Limits

Material	Durometer	Temperature Limits				Material	Durometer	Temperature Limits			
		min.		max.				min.		max.	
		°F	°C	°F	°C			°F	°C	°F	°C
Nitrile (Buna-N) ²	70	-40	-40.0	250	121.1	Silicone [®]	70	-65	-53.9	437	225
	90	-40	-40.0	250	121.1	Teflon [®]	N/A	-300	-184.4	505	262.8
Ethylene/ Propylene	70	-65	-53.9	212	100.0	Kalrez ^{®1}	82	-4	-20.0	550	287.8
	90	-70	-56.7	500	260.0		75	-4	-20.0	600	315.6
Fluorocarbon (Viton)	75	-15	-26.1	400	204.4		91	-4	-20.0	550	287.8
	90	-15	-26.1	400	204.4		75	-4	-20.0	525	273.9
Neoprene [®]	70	-45	-42.8	300	148.9	Chemraz ^{®1}	90	-20	-28.9	500	260

Notes:

1. Consult application engineer before selecting.
2. Standard O-ring Material.

Table 3: Pilot Valve and modulator Pressure/Temperature Limits

Service	O-ring Material ²	Durometer	Temperature Limit				Pressure Limits			
			min.		max.		min.		max.	
			°F	°C	°F	°C	psig	barg	psig	barg
LA/GS	Nitrile (Buna-N) ³	70	-40	-40.0	250	121.1	15	1.03	3750	258.55
LA/GS		90	-40	-40.0	250	121.1	3751	258.62	6250	430.92
LA/GS	Fluorocarbon (Viton)	75	-15	-26.1	400	204.4	15	1.03	3750	258.55
LA/GS		90	-15	-26.1	400	204.4	3751	258.62	6250	430.92
LA/GS	Ethylene Propylene	70	-40	-40.0	212	100.0	15	1.03	3750	258.55
LA/GS		90	-40	-40.0	250	121.1	3751	258.62	6250	430.92
SS	Kalrez ¹	90	212	100.0	500	260.0	15	1.03	680	46.88
LA/GS		-	-40	-40.0	505	262.8	15	1.03	6250	430.92
LA/GS	Teflon	N/A	-40	-40.0	505	262.8	50	3.45	6250	430.92
SS		N/A	212	100.0	505	262.8	50	3.45	3750	258.55

Notes:

1. Consult factory concerning use of Kalrez.
2. Other materials are dependant upon application. Consult factory for availability of other materials.
3. Standard O-ring material.

Pilot Designs

Introduction

With its modular design, BHGE's Consolidated pilot valve can be used in applications that require a pop or a modulating action. The modular design concept allows the pop pilot to be used for modulation by simply adding a small compact modulator to the pop pilot. By removing the modulator, the pilot valve is returned to a pop pilot. End users can modify their pilot valve population to meet their changing requirements at a minimum expense.

A pilot design selection is determined primarily on the following:

- 1) Need for either pop action or modulating action, which describes the operating motion of the disc
- 2) Set pressure limits
- 3) Temperature limits
- 4) The service application

This section describes the following pilot designs:

- 39PV Pop Action - Non-Flowing
- 39MV Modulating Action - Non-Flowing

Remote Sensing at the Source of System Pressure

On the standard product, the sensing line is not connected directly at the main valve inlet. The system pressure is sensed remotely or at the pressure vessel and equipment that is being protected.

If the pressure drop from the equipment being protected to the relief valve inlet exceeds 3 percent, remote sensing can provide a solution. Remote sensing minimizes the effects of excessive inlet pressure loss and eliminates the resulting valve chatter. The modulator is suggested when the POSRV could relieve at various capacity levels.

The 2900 series valves with remote sensing are ideal for upgrading current Consolidated 1900 series valves and competitors' safety relief valves to the new 2900 pilot-operated safety relief valve, because the center-to-face dimensions on both the inlet and outlet are the same .

Pilot Designs

Non-Flowing Pilot-Operated Safety Relief Valves

2900 Series Valve with 39PV Pop Action



2900 Series Valve with 39MV Modulating Action

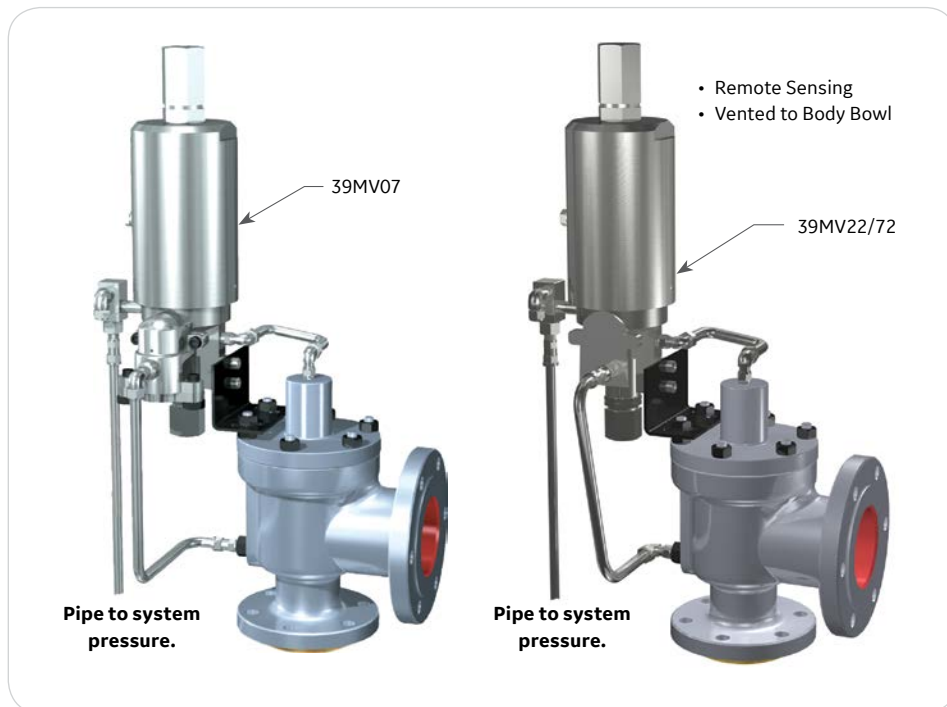

Pilot Materials (PV)

Pop Action, Non-Flowing For Set Pressures

[15 to 3750 psig (1.03 to 258.55 barg)]

2900 Series Valve with 39PV Pop Action



Unique Characteristics

BHGE's Consolidated 39PV07 pop action non-flowing pilot provides excellent performance with full lift at set pressure with minimal blowdown. Buna N O-rings and 316 stainless steel construction throughout are standard. The pilot is non-flowing at full open, improving its capabilities to handle dirty conditions and reduce icing problems. The 39PV pilot has two unique features: It has the ability to be used on liquid, gas or steam service without any adjustments, and it may be converted to the 39MV07 modulating pilot by simply installing the modulator assembly. This simple, modular design allows for easier maintenance and fewer spare parts. The 39PV37 pop action pilot is not convertible to a 39MV22 modulating pilot.

Set pressures are field adjustable and testing is easily performed using the standard field test connection. Manual blowdown, sensing line filter, backflow preventer, and remote sensing are available as options.

Pilot Materials (PV)

39PV07/37 Pilot Construction

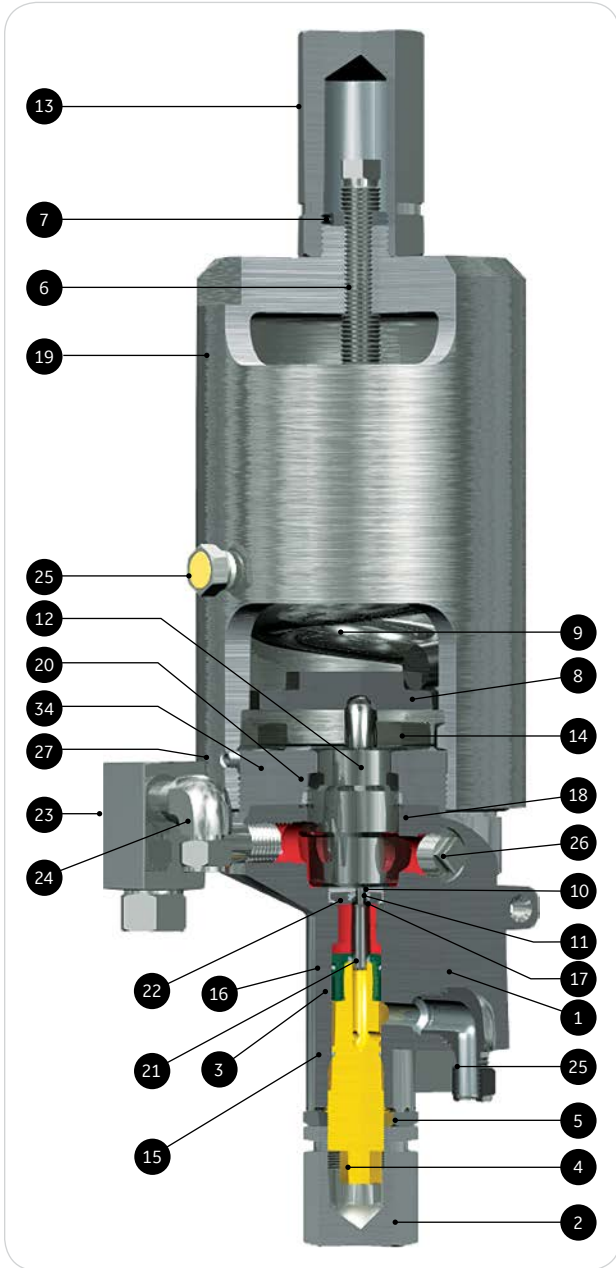

High Pressure

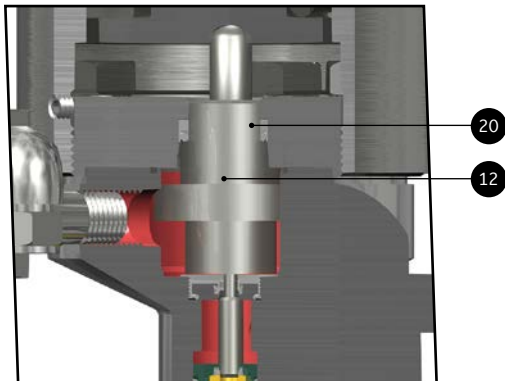

39PV07/37 Pilot Standard Material Variation		
Ref. No.	Nomenclature	Material (-CC)
1	Main Base	ASME SA351 CF8M St. St.
2	Adjuster Cap	316 Stainless Steel
3	Adjuster Top	316 Stainless Steel
4	Adjuster Bottom	316 Stainless Steel
5	Adjuster Lock Nut	316 Stainless Steel
6	Compression Screw	316 Stainless Steel
7	Compression Screw Lock Nut	316 Stainless Steel
8	Spring Washer	316 Stainless Steel
9	Spring	Chrome St. (Phosphate Coated)
10	Insert Top	316 Stainless Steel
11	Insert Bottom	316 Stainless Steel
12	Main Piston	316 Stainless Steel
13	Cap (Compression Screw)	316 Stainless Steel
14	Cap Screw (Top Plate)	ASME SA193 B8M St. St.
15	O-ring (Adjuster Bottom)	Select
16	O-ring (Adjuster Top)	Select
17	O-ring (Insert)	Select
18	O-ring (Top Plate)	Select
19	Bonnet	ASME SA351 CF8M St. St.
20	Spring Seal (Main Piston)	Teflon
21	Spring Seal (Adjuster Top)	Teflon
22	Spring Seal (Insert)	Teflon
23	Field Test Connector	
	Ball	316 Stainless Steel
	Seat O-ring	Select
	Plug O-ring	Select
	Shuttle Base	316 Stainless Steel
	Shuttle Plug	316 Stainless Steel
	Tube Filter	304 Stainless Steel
24	Vent Assembly/Bug Screen (Field Test Connection)	
	Male Elbow	316 Stainless Steel
	Screen	304 Stainless Steel
25	Vent Assembly (Bonnet Vent) ¹	Nickel Steel/Bronze
26	Pipe Plug (Pilot Valve)	304 Stainless Steel
27	Set Screw (Bonnet)	316 Stainless Steel
34	Top Plate	316 Stainless Steel

Notes:

1. Standard material is a filter plug. For special materials, vent assembly is supplied.

Pilot Special Materials (PV)

39PV07/37 Pilot Standard Material Variation

Alloy 20 Construction

Alloy 20 Construction ^{1,2}		
Part	Construction Variation	
	A1	A4
Main Base, Insert Top, Insert Bottom, Main Piston	Alloy 20	Alloy 20
Adjuster Cap	316 Stainless Steel	Alloy 20
Adjuster Top, Adjuster Bottom	Alloy 20	Alloy 20
Adjuster Lock Nut, Compression Screw	316 Stainless Steel	Alloy 20
Compression Screw Lock Nut, Spring Washer	316 Stainless Steel	Alloy 20
Spring	Chrome Steel (Phosphate Coated)	Inconel X-750
Cap (Compression Screw)	316 Stainless Steel	Alloy 20
Cap Screw (Top Plate)	ASME SA193 B8M Stainless Steel	Alloy 20
O-ring (Adjuster Bottom, Adjuster Top, Insert, Top Plate)	Select	Select
Bonnet	ASME SA351 CF8M Stainless Steel	Alloy 20
Spring Seal (Main Piston, Adjuster Top, Insert)	Teflon	Teflon
Field Test Connector		
Ball	Alloy 20	Alloy 20
Seat O-ring, Plug O-ring	Select	Select
Shuttle Base, Shuttle Plug	Alloy 20	Alloy 20
Tube Filter	Alloy 20	Alloy 20
Vent Assembly/Bug Screen (Field Test Connection)		
Male Elbow	316 Stainless Steel	Alloy 20
Screen	304 Stainless Steel	304 Stainless Steel
Vent Assembly (Bonnet Vent) ³	Nickel Steel/Bronze	
Male Elbow	-	Alloy 20
Screen	-	304 Stainless Steel
Pipe Plug (Pilot Valve), Tube Fittings, Tube Lines, Top Plate	Alloy 20	Alloy 20
Set Screw (Bonnet)	316 Stainless Steel	Alloy 20
Lifting Lever Assembly ⁴		
Cam Bushing, Cam Shaft, Lifting Lever	316 Stainless Steel	Alloy 20
Drive Pin	303 Stainless Steel	Alloy 20
Release Nut, Release Locknut	316 Stainless Steel	Alloy 20
Gag Bolt ⁴	316 Stainless Steel	316 Stainless Steel
39PV-3		
Cap (Compression Screw), Sealing Plug	316 Stainless Steel	Alloy 20
Bonnet, Compression Screw	316 Stainless Steel	Alloy 20
Compression Screw Lock Nut, Top Spring Washer	316 Stainless Steel	Alloy 20
Lower Spring Washer Assembly		
Spring Washer, Lifting Stem	316 Stainless Steel	Alloy 20
Drive Pin	303 Stainless Steel	Alloy 20

Notes:

1. The materials in red denote variation from standard material construction.
2. To specify valves, add material designation to the valve type 39PV/A4.
3. Standard material is a filter plug. For special materials, vent assembly is supplied.
4. 39PV-3 design is required for this option.

Pilot Special Materials (PV)

39PV07/37 Pilot Standard Material Variation

Duplex Construction

Duplex Construction ^{1,2,3}		
Part	Construction Variation	
	D1	D4
Main Base, Adjuster Top, Adjuster Bottom	Duplex	Duplex
Adjuster Cap, Adjuster Lock Nut, Compression Screw	316 Stainless Steel	Duplex
Compression Screw Lock Nut, Spring Washer	316 Stainless Steel	Duplex
Spring	Chrome Steel (Phosphate Coated)	Inconel X-750
Insert Top, Insert Bottom, Main Piston	Duplex	Duplex
Cap (Compression Screw), Cam Bushing, Cam Shaft	316 Stainless Steel	Duplex
Cap Screw (Top Plate)	ASME SA193 B8M Stainless Steel	Duplex
O-ring (Adjuster Bottom, Adjuster Top, Insert, Top Plate)	Select	Select
Bonnet	ASME SA351 CF8M Stainless Steel	Duplex
Spring Seal (Main Piston, Adjuster Top, Insert)	Teflon	Teflon
Field Test Connector		
Ball	316 Stainless Steel ⁶	316 Stainless Steel ⁶
Seat O-ring, Plug O-ring	Select	Select
Shuttle Base, Shuttle Plug	Duplex	Duplex
Tube Filter	304 Stainless Steel ⁶	304 Stainless Steel ⁶
Vent Assembly/Bug Screen (Field Test Connection)		
Male Elbow	316 Stainless Steel	Duplex ⁷
Screen	304 Stainless Steel	304 Stainless Steel
Vent Assembly (Bonnet Vent) ⁴	Nickel Steel/Bronze	
Male Elbow	-	Duplex ⁷
Screen	-	304 Stainless Steel
Pipe Plug (Pilot Valve)	Duplex	Duplex
Tube Fittings, Tube Lines, Top Plate	Duplex ⁷	Duplex ⁷
Set Screw (Bonnet)	316 Stainless Steel	Duplex
Lifting Lever Assembly ⁵		
Lifting Lever, Release Nut, Release Locknut	316 Stainless Steel	Duplex
Drive Pin	303 Stainless Steel	Duplex
Gag Bolt ⁵	316 Stainless Steel	316 Stainless Steel
39PV-3		
Cap (Compression Screw), Sealing Plug	316 Stainless Steel	Duplex
Bonnet, Compression Screw	316 Stainless Steel	Duplex
Compression Screw Lock Nut, Top Spring Washer	316 Stainless Steel	Duplex
Lower Spring Washer Assembly		
Spring Washer, Lifting Stem	316 Stainless Steel	Duplex
Drive Pin	303 Stainless Steel	Duplex

Notes:

1. The materials in red denote variation from standard material construction.
2. To specify valves, add material designation to the valve type 39PV/D4.
3. Parts from casting shall be constructed from ASME SA995 Grade CE8MN Duplex. Parts from barstock shall be constructed from ASME SA479 UNS S31803 Duplex.
4. Standard material is a filter plug. For special materials, vent assembly is supplied.
5. 39PV-3 design is required for this option.
6. Can not get filter or .281" (7.14 mm) ball in Duplex material
7. All tube fittings and/or valves shall be made from Grade SAF 2507, UNS S32750. Tubes shall be made from ASTM A789, Grade SAF2507, UNS S32750. Note: Do not mix components from other materials with SAF 2507, UNS S32750.

Pilot Special Materials (PV)

39PV07/37 Pilot Standard Material Variation

Hastelloy Construction

Hastelloy Construction ^{1,2}		
Part	Construction Variation	
	H1	H4
Main Base	ASME SA494 CW12MW Nickel Alloy	ASME SA494 CW12MW Nickel Alloy
Adjuster Cap, Cap (Compression Screw)	316 Stainless Steel	Hastelloy
Adjuster Top, Adjuster Bottom	Hastelloy	Hastelloy
Adjuster Lock Nut, Compression Screw	316 Stainless Steel	Hastelloy
Compression Screw Lock Nut, Spring Washer	316 Stainless Steel	Hastelloy
Spring	Chrome Steel (Phosphate Coated)	Inconel X-750
Insert Top, Insert Bottom, Main Piston	Hastelloy	Hastelloy
Cap Screw (Top Plate)	ASME SA193 B8M Stainless Steel	Hastelloy
O-ring (Adjuster Bottom, Adjuster Top, Insert, Top Plate)	Select	Select
Bonnet	ASME SA351 CF8M Stainless Steel	Hastelloy
Spring Seal (Main Piston, Adjuster Top, Insert)	Teflon	Teflon
Field Test Connector		
Ball	Hastelloy	Hastelloy
Seat O-ring, Plug O-ring	Select	Select
Shuttle Base, Shuttle Plug, Tube Filter	Hastelloy	Hastelloy
Vent Assembly/Bug Screen (Field Test Connection)		
Male Elbow	316 Stainless Steel	Hastelloy
Screen	304 Stainless Steel	304 Stainless Steel
Vent Assembly (Bonnet Vent) ³	Nickel Steel/Bronze	
Male Elbow	-	Hastelloy
Screen	-	304 Stainless Steel
Pipe Plug (Pilot Valve), Tube Fittings	Hastelloy	Hastelloy
Tube Lines, Top Plate	Hastelloy	Hastelloy
Set Screw (Bonnet)	316 Stainless Steel	Hastelloy
Lifting Lever Assembly ⁴		
Cam Bushing, Cam Shaft, Lifting Lever	316 Stainless Steel	Hastelloy
Release Nut, Release Locknut	316 Stainless Steel	Hastelloy
Drive Pin	303 Stainless Steel	Hastelloy
Gag Bolt ⁴	316 Stainless Steel	316 Stainless Steel
39PV-3		
Cap (Compression Screw), Sealing Plug	316 Stainless Steel	Hastelloy
Bonnet, Compression Screw	316 Stainless Steel	Hastelloy
Compression Screw Lock Nut, Top Spring Washer	316 Stainless Steel	Hastelloy
Lower Spring Washer Assembly		
Spring Washer, Lifting Stem	316 Stainless Steel	Hastelloy
Drive Pin	303 Stainless Steel	Hastelloy

Notes:

1. The materials in red denote variation from standard material construction.
2. To specify valves, add material designation to the valve type 39PV/H4.
3. Standard material is a filter plug. For special materials, vent assembly is supplied.
4. 39PV-3 design is required for this option.

Pilot Special Materials (PV)

39PV07/37 Pilot Standard Material Variation

Monel Construction

Monel Construction ^{1,2}		
Part	Construction Variation	
	M1	M4
Main Base	ASME SA494 M35-1 NCA3	ASME SA494 M35-1 NCA3
Adjuster Cap, Adjuster Lock Nut, Compression Screw	316 Stainless Steel	Monel
Adjuster Top, Adjuster Bottom	Monel	Monel
Compression Screw Lock Nut, Spring Washer	316 Stainless Steel	Monel
Spring	Chrome Steel (Phosphate Coated)	Inconel X-750
Insert Top, Insert Bottom, Main Piston	Monel	Monel
Cap (Compression Screw)	316 Stainless Steel	Monel
Cap Screw (Top Plate)	ASME SA193 B8M Stainless Steel	Monel
O-ring (Adjuster Bottom, Adjuster Top, Insert, Top Plate)	Select	Select
Bonnet	ASME SA351 CF8M Stainless Steel	Monel
Spring Seal (Main Piston, Adjuster Top, Insert)	Teflon	Teflon
Field Test Connector		
Ball, Shuttle Base, Shuttle Plug, Tube Filter	Monel	Monel
Seat O-ring, Plug O-ring	Select	Select
Vent Assembly/Bug Screen (Field Test Connection)		
Male Elbow	316 Stainless Steel	Monel
Screen	304 Stainless Steel	304 Stainless Steel
Vent Assembly (Bonnet Vent) ⁴	Nickel Steel/Bronze	
Male Elbow	-	Monel
Screen	-	304 Stainless Steel
Pipe Plug (Pilot Valve), Top Plate	Monel	Monel
Tube Fittings, Tube Lines	316 Stainless Steel	Monel
Set Screw (Bonnet)	316 Stainless Steel	Monel
Lifting Lever Assembly ⁵		
Cam Bushing, Cam Shaft, Lifting Lever	316 Stainless Steel	Monel
Release Nut, Release Locknut	316 Stainless Steel	Monel
Drive Pin	303 Stainless Steel	Monel
Gag Bolt ⁵	316 Stainless Steel	316 Stainless Steel
39PV-3		
Cap (Compression Screw), Sealing Plug	316 Stainless Steel	Monel
Bonnet, Compression Screw	316 Stainless Steel	Monel
Compression Screw Lock Nut, Top Spring Washer	316 Stainless Steel	Monel
Lower Spring Washer Assembly		
Spring Washer, Lifting Stem	316 Stainless Steel	Monel
Drive Pin	303 Stainless Steel	Monel

Notes:

1. The materials in red denote variation from standard material construction.
2. To specify valves, add material designation to the valve type 39PV/H4.
3. Nickel Copper Alloy (ASME Code Case 1750-22).
4. Standard material is a filter plug. For special materials, vent assembly is supplied.
5. 39PV-3 design is required for this option.

Pilot Special Materials (PV)

39PV07/37 Pilot Standard Material Variation

Sour Gas Service [SG]

Materials for Sour Gas Service ^{1,2}	
Part	Construction Variation - SG
Main Base	SA351 Grade CF8M Stainless Steel
Adjuster Cap, Adjuster Top, Adjuster Bottom	316 Stainless Steel
Compression Screw, Compression Screw Lock Nut	316 Stainless Steel
Adjuster Lock Nut, Insert Top, Insert Bottom, Main Piston	316 Stainless Steel
Spring	Inconel X-750
Spring Washer, Cap (Compression Screw)	316 Stainless Steel
Cap Screw (Top Plate)	ASME SA193 B8M Stainless Steel
O-ring (Adjuster Bottom, Adjuster Top, Insert, Top Plate)	Select
Bonnet	ASME SA351 CF8M Stainless Steel
Spring Seal (Main Piston, Adjuster Top, Insert)	Teflon
Field Test Connector	
Ball, Shuttle Base, Shuttle Plug	316 Stainless Steel
Seat O-ring, Plug O-ring	Select
Tube Filter	304 Stainless Steel
Vent Assembly/Bug Screen (Field Test Connection)	
Male Elbow	316 Stainless Steel
Screen	304 Stainless Steel
Vent Assembly (Bonnet Vent) ³	Nickel Steel/Bronze
Pipe Plug (Pilot Valve)	304 Stainless Steel
Tube Fittings, Tube Lines, Top Plate, Set Screw (Bonnet)	316 Stainless Steel
Lifting Lever Assembly ⁴	
Cam Bushing, Cam Shaft, Lifting Lever	316 Stainless Steel
Drive Pin	303 Stainless Steel
Release Nut, Release Locknut	316 Stainless Steel
Gag Bolt ⁴	316 Stainless Steel
39PV-3	
Cap (Compression Screw), Sealing Plug, Bonnet	316 Stainless Steel
Compression Screw, Compression Screw Lock Nut	316 Stainless Steel
Top Spring Washer	316 Stainless Steel
Lower Spring Washer Assembly	
Spring Washer, Lifting Stem	316 Stainless Steel
Drive Pin	303 Stainless Steel

Notes:

1. The materials in red denote variation from standard material construction.
2. To specify valves, add material designation to the valve type 39PV/SG.
3. Standard material is a filter plug. For special materials, vent assembly is supplied.
4. 39PV-3 design is required for this option.

Pilot Special Materials (PV)

39PV07/37 Pilot Dirty Service Material Variation

Dirty Service - Standard & Sour Gas

Dirty Service - Standard & Sour Gas ²		
Part	Dirty Service Material Construction Variation	
	Standard (-CC & -DS)	Sour Gas (-SG & -DS) ¹
Main Base	ASME SA351 CF8M Stainless Steel	ASME SA351 CF8M Stainless Steel
Adjuster Cap, Adjuster Top, Adjuster Bottom	316 Stainless Steel	316 Stainless Steel
Adjuster Lock Nut, Compression Screw	316 Stainless Steel	316 Stainless Steel
Compression Screw Lock Nut, Spring Washer	316 Stainless Steel	316 Stainless Steel
Spring	Chrome Steel (Phosphate Coated)	Chrome Steel (Phosphate Coated)
Insert Top		
Clean Service Media (CS), Dirty Service Media (DS)	316 Stainless Steel	316 Stainless Steel
Insert Bottom		
Clean Service Media (CS), Dirty Service Media (DS)	316 Stainless Steel	316 Stainless Steel
Main Piston, Cap (Compression Screw)	316 Stainless Steel	316 Stainless Steel
Cap Screw (Top Plate)	ASME SA193 B8M Stainless Steel	ASME SA193 B8M Stainless Steel
O-ring (Adjuster Bottom, Adjuster Top, Insert, Top Plate)	Select	Select
Bonnet	ASME SA351 CF8M Stainless Steel	ASME SA351 CF8M Stainless Steel
Spring Seal (Main Piston, Adjuster Top, Insert)	Teflon	Teflon
Field Test Connector		
Ball, Shuttle Base, Shuttle Plug	316 Stainless Steel	316 Stainless Steel
Seat O-ring, Plug O-ring	Select	Select
Tube Filter	304 Stainless Steel	304 Stainless Steel
Vent Assembly/Bug Screen (Field Test Connection)		
Male Elbow	316 Stainless Steel	316 Stainless Steel
Screen	304 Stainless Steel	304 Stainless Steel
Vent Assembly (Bonnet Vent) ³	Nickel Steel/Bronze	Nickel Steel/Bronze
Pipe Plug (Pilot Valve)	316 Stainless Steel	316 Stainless Steel
Tube Fittings		
Clean Service Media (CS), Dirty Service Media (DS)	316 Stainless Steel	316 Stainless Steel
Tube Lines		
Clean Service Media (CS), Dirty Service Media (DS)	316 Stainless Steel	316 Stainless Steel
Top Plate, Set Screw (Bonnet), Dirty Service Insert	316 Stainless Steel	316 Stainless Steel
Regulator	Aluminum/Brass	Aluminum/Brass
Lifting Lever Assembly ⁴		
Cam Bushing, Cam Shaft, Lifting Lever	316 Stainless Steel	316 Stainless Steel
Drive Pin	303 Stainless Steel	303 Stainless Steel
Release Nut, Release Locknut	316 Stainless Steel	316 Stainless Steel
Gag Bolt ⁴	316 Stainless Steel	316 Stainless Steel
39PV-3		
Cap (Compression Screw), Sealing Plug, Bonnet	316 Stainless Steel	316 Stainless Steel
Compression Screw, Compression Screw Lock Nut	316 Stainless Steel	316 Stainless Steel
Top Spring Washer	316 Stainless Steel	316 Stainless Steel
Lower Spring Washer Assembly		
Spring Washer, Lifting Stem	316 Stainless Steel	316 Stainless Steel
Drive Pin	303 Stainless Steel	303 Stainless Steel

Notes:

1. The materials in red denote variation from standard material construction.
2. To specify valves, add material designation to the valve type 39PV/CC&DS or 39PV/SG&DS.
3. Standard material is a filter plug. For special materials, vent assembly is supplied.
4. 39PV-3 design is required for this option.

Pilot Special Materials (PV)

39PV07/37 Pilot Dirty Service Material Variation

Dirty Service - Monel and Hastelloy

Dirty Service - Monel and Hastelloy ^{1,2}		
Part	Dirty Service Material Construction Variation	
	Monel (-M1 & -DS)	Hastelloy (-H1 & -DS)
Main Base	ASME SA351 CF8M Stainless Steel	ASME SA351 CF8M Stainless Steel
Adjuster Cap, Adjuster Top, Adjuster Bottom	316 Stainless Steel	316 Stainless Steel
Adjuster Lock Nut, Compression Screw	316 Stainless Steel	316 Stainless Steel
Compression Screw Lock Nut, Spring Washer	316 Stainless Steel	316 Stainless Steel
Spring	Chrome Steel (Phosphate Coated)	Chrome Steel (Phosphate Coated)
Insert Top, Insert Bottom		
Clean Service Media (CS)	316 Stainless Steel	316 Stainless Steel
Dirty Service Media (DS)	Monel	Hastelloy
Main Piston	Monel	Hastelloy
Cap (Compression Screw)	316 Stainless Steel	316 Stainless Steel
Cap Screw (Top Plate)	ASME SA193 B8M Stainless Steel	ASME SA193 B8M Stainless Steel
O-ring (Adjuster Bottom, Adjuster Top, Insert, Top Plate)	Select	Select
Bonnet	ASME SA351 CF8M Stainless Steel	ASME SA351 CF8M Stainless Steel
Spring Seal (Main Piston, Adjuster Top, Insert)	Teflon	Teflon
Field Test Connector		
Ball, Shuttle Base, Shuttle Plug, Tube Filter	Monel	Hastelloy
Seat O-ring, Plug O-ring	Select	Select
Vent Assembly/Bug Screen (Field Test Connection)		
Male Elbow	316 Stainless Steel	316 Stainless Steel
Screen	304 Stainless Steel	304 Stainless Steel
Vent Assembly (Bonnet Vent) ³	Nickel Steel/Bronze	Nickel Steel/Bronze
Pipe Plug (Pilot Valve)	316 Stainless Steel	316 Stainless Steel
Tube Fittings, Tube Lines		
Clean Service Media (CS)	316 Stainless Steel	316 Stainless Steel
Dirty Service Media (DS)	Monel	Hastelloy
Top Plate, Dirty Service Insert	Monel	Hastelloy
Set Screw (Bonnet)	316 Stainless Steel	316 Stainless Steel
Regulator	Aluminum/Brass	Aluminum/Brass
Lifting Lever Assembly ⁴		
Cam Bushing, Cam Shaft, Lifting Lever	316 Stainless Steel	316 Stainless Steel
Drive Pin	303 Stainless Steel	303 Stainless Steel
Release Nut, Release Locknut	316 Stainless Steel	316 Stainless Steel
Gag Bolt ⁴	316 Stainless Steel	316 Stainless Steel
39PV-3		
Cap (Compression Screw), Sealing Plug	316 Stainless Steel	316 Stainless Steel
Bonnet, Compression Screw	316 Stainless Steel	316 Stainless Steel
Compression Screw Lock Nut, Top Spring Washer	316 Stainless Steel	316 Stainless Steel
Lower Spring Washer Assembly		
Spring Washer, Lifting Stem	316 Stainless Steel	316 Stainless Steel
Drive Pin	303 Stainless Steel	303 Stainless Steel

Notes:

1. The materials in red denote variation from standard material construction.
2. To specify valves, add material designation to the valve type 39PV/M1&DS or 39PV/H1&DS.
3. Standard material is a filter plug. For special materials, vent assembly is supplied.
4. 39PV-3 design is required for this option.

Pilot Special Materials (PV)

39PV07/37 Pilot Dirty Service Material Variation

Dirty Service - Duplex & Alloy 20

Dirty Service - Duplex & Alloy 20 ^{1,2}		
Part	Dirty Service Material Construction Variation	
	Duplex (-D1 & -DS) ³	Alloy 20 (-A1 & -DS)
Main Base	ASME SA351 CF8M Stainless Steel	ASME SA351 CF8M Stainless Steel
Adjuster Cap, Adjuster Top, Adjuster Bottom, Adjuster Lock Nut	316 Stainless Steel	316 Stainless Steel
Compression Screw, Compression Screw Lock Nut, Spring Washer	316 Stainless Steel	316 Stainless Steel
Spring	Chrome Steel (Phosphate Coated)	Chrome Steel (Phosphate Coated)
Insert Top, Insert Bottom		
Clean Service Media (CS)	316 Stainless Steel	316 Stainless Steel
Dirty Service Media (DS)	Duplex	Alloy 20
Main Piston	Duplex	Alloy 20
Cap (Compression Screw)	316 Stainless Steel	316 Stainless Steel
Cap Screw (Top Plate)	ASME SA193 B8M Stainless Steel	ASME SA193 B8M Stainless Steel
O-ring (Adjuster Bottom, Adjuster Top, Insert, Top Plate)	Select	Select
Bonnet	ASME SA351 CF8M Stainless Steel	ASME SA351 CF8M Stainless Steel
Spring Seal (Main Piston, Adjuster Top, Insert)	Teflon	Teflon
Field Test Connector		
Ball	316 Stainless Steel ⁴	Alloy 20
Seat O-ring, Plug O-ring	Select	Select
Shuttle Base, Shuttle Plug	Duplex	Alloy 20
Tube Filter	304 Stainless Steel ⁴	Alloy 20
Vent Assembly/Bug Screen (Field Test Connection)		
Male Elbow	316 Stainless Steel	316 Stainless Steel
Screen	304 Stainless Steel	304 Stainless Steel
Vent Assembly (Bonnet Vent) ⁵	Nickel Steel/Bronze	Nickel Steel/Bronze
Male Elbow	-	-
Screen	-	-
Pipe Plug (Pilot Valve)	316 Stainless Steel	316 Stainless Steel
Tube Fittings, Tube Lines		
Clean Service Media (CS)	316 Stainless Steel	316 Stainless Steel
Dirty Service Media (DS)	Duplex ⁶	Alloy 20
Top Plate	Duplex	Alloy 20
Set Screw (Bonnet)	316 Stainless Steel	316 Stainless Steel
Dirty Service Insert	Duplex	316 Stainless Steel
Regulator	Aluminum/Brass	Aluminum/Brass
Lifting Lever Assembly ⁷		
Cam Bushing, Cam Shaft, Lifting Lever	316 Stainless Steel	316 Stainless Steel
Drive Pin	303 Stainless Steel	303 Stainless Steel
Release Nut, Release Locknut	316 Stainless Steel	316 Stainless Steel
Gag Bolt ⁷	316 Stainless Steel	316 Stainless Steel
39PV-3		
Cap (Compression Screw), Sealing Plug, Top Spring Washer	316 Stainless Steel	316 Stainless Steel
Compression Screw, Compression Screw Lock Nut, Bonnet	316 Stainless Steel	316 Stainless Steel
Lower Spring Washer Assembly		
Spring Washer, Lifting Stem	316 Stainless Steel	316 Stainless Steel
Drive Pin	303 Stainless Steel	303 Stainless Steel

Notes:

1. The materials in red denote variation from standard material construction.
2. To specify valves, add material designation to the valve type 39PV/D1&DS or 39PV/A1&DS.
3. Parts from casting shall be constructed from ASME SA995 Grade CE8MN Duplex. Parts from barstock shall be constructed from ASME SA479 UNS S31803 Duplex Standard material is a filter plug.
4. Cannot get filter or .281" (7.14 mm) ball in Duplex material.
5. For special materials, vent assembly is supplied.
6. All tube fittings and/or valves shall be made from grade SAF 2507, UNS S32750. Tubes shall be made from ASTM A789, grade SAF 2507, UNS S32750.
7. 39PV-3 design is required for this option.

Pilot Materials (MV)

Modulating Action, Non-Flowing For Set Pressures

[15 to 6250 psig (1.03 to 430.92 barg)]

2900 Series Valve with 39MV Modulating Action

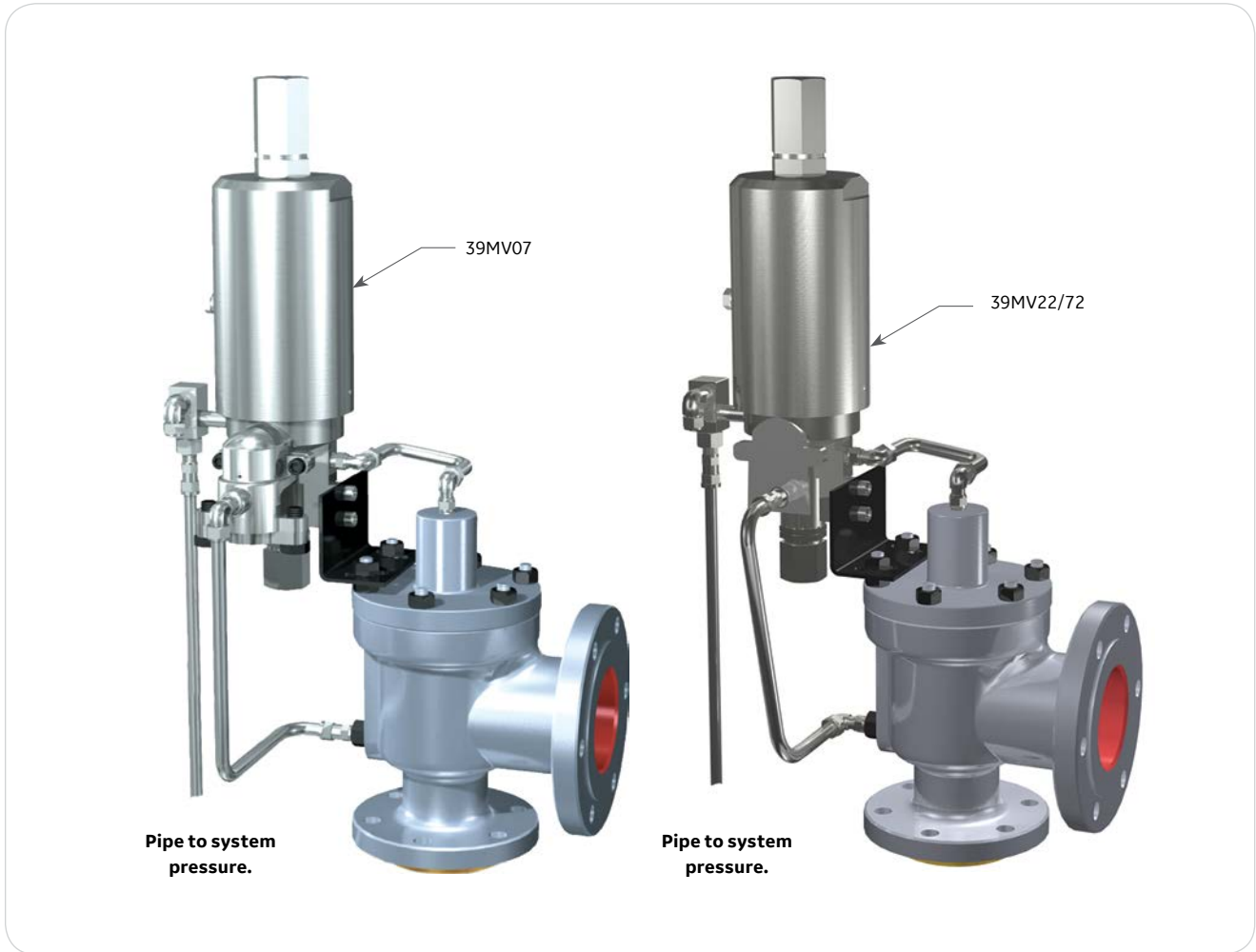

Quality, Reliability, Simplicity

The Consolidated 39MV Pilot-Operated Safety Relief Valve is a non-flowing modulating pilot valve that provides exceptional performance and stable operation. Since the 39MV design controls the attached main valve, relieving only enough system pressure to control the system upset, loss of media is minimal. This patented technology is the latest advancement in pilot design within the pressure range of 15 to 6250 psig (1.03 to 430.92 barg) for vapor, gas and liquid service, and 15 to 3750 psig (258.55 barg) for steam service. The 39MV design is the only non-flowing modulating valve of its kind available with adjustable blowdown. The unique modulator of

the 39MV07 pilot is an addition to the 39PV pop action design whose simplicity allows for easier maintenance and for lower spare parts inventory.

The 39MV22/72 modulating pilot features a modulator built into the pilot valve. This design reduces product cost, improves modulating performance, and increases energized seal life as well as the capable pressure range of the pilot valve to 6250 psig (430.92 barg).

Pilot Materials (MV)

2900 Series Valve Type 39MV07 Pilot

[15 to 750 psig (1.03 to 51.71 barg)]

39MV07 Pilot Construction

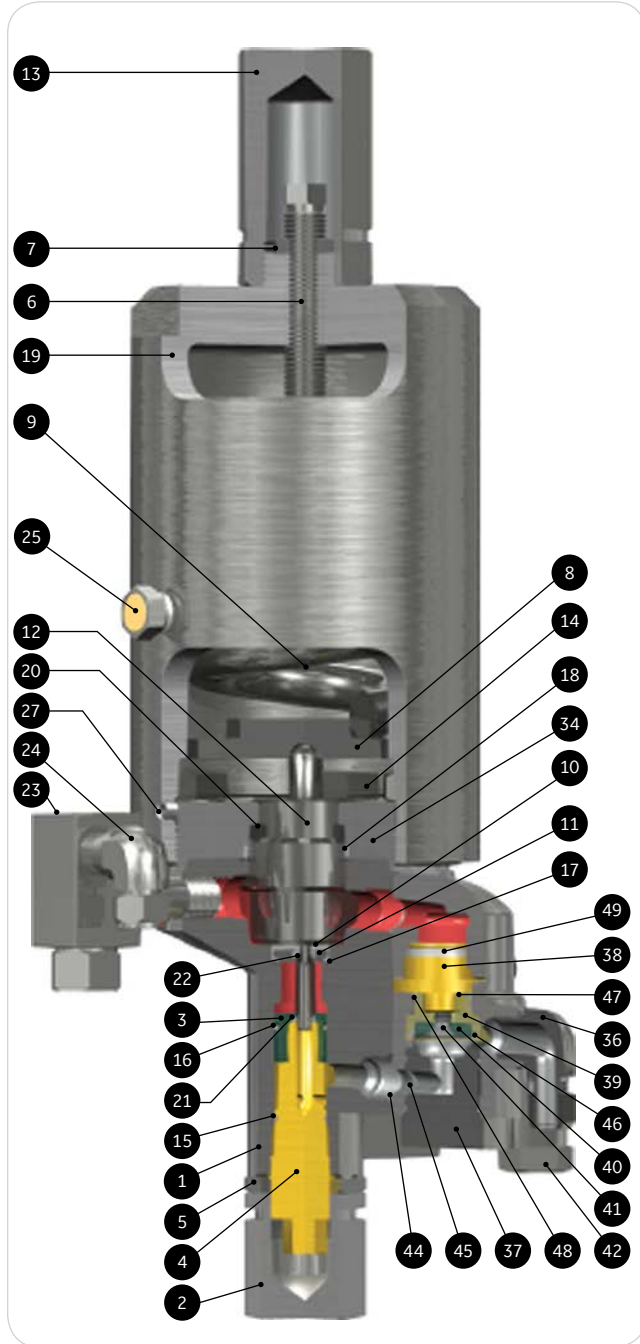

High Pressure

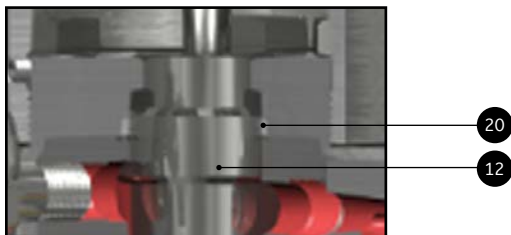

39MV07 Pilot Standard Material Variation

Ref. No.	Nomenclature	Material
1	Main Base	SA351 Grade CF8M St. St.
2	Adjuster Cap	316 Stainless Steel
3	Adjuster Top	316 Stainless Steel
4	Adjuster Bottom	316 Stainless Steel
5	Adjuster Lock Nut	316 Stainless Steel
6	Compression Screw	316 Stainless Steel
7	Compression Screw Lock Nut	316 Stainless Steel
8	Spring Washer	316 Stainless Steel
9	Spring	Chrome St. (Phosphate Coated)
10	Insert Top	316 Stainless Steel
11	Insert Bottom	316 Stainless Steel
12	Main Piston	316 Stainless Steel
13	Cap (Compression Screw)	316 Stainless Steel
14	Cap Screw (Top Plate)	316 Stainless Steel
15	O-ring (Adjuster Bottom)	Select
16	O-ring (Adjuster Top)	Select
17	O-ring (Insert)	Select
18	O-ring (Top Plate)	Select
19	Bonnet	SA351 Grade CF8M St. St.
20	Spring Seal (Main Piston)	Teflon
21	Spring Seal (Adjuster Top)	Teflon
22	Spring Seal (Insert)	Teflon
23	Field Test Connector	
	Ball	316 Stainless Steel
	Seat O-ring	Select
	Plug O-ring	Select
	Shuttle Base	316 Stainless Steel
	Shuttle Plug	316 Stainless Steel
	Tube Filter	304 Stainless Steel
24	Vent Assembly/Bug Screen (Field Test Connection)	
	Male Elbow	316 Stainless Steel
	Screen	304 Stainless Steel
25	Vent Assembly (Bonnet Vent) ¹	Nickel Steel/Bronze
27	Set Screw (Bonnet)	316 Stainless Steel
34	Top Plate	316 Stainless Steel
35	Plug Filter	SA351 Grade CF8M St. St.
36	Modulator Base	SA351 Grade CF8M St. St.
37	Modulator Stop	316 Stainless Steel
38	Modulator Piston Top	316 Stainless Steel
39	Modulator Piston Bottom	316 Stainless Steel
40	O-ring Retainer	316 Stainless Steel
41	Lock Screw (Retainer)	316 Stainless Steel
42	Cap Screw (Modulator)	316 Stainless Steel
43	Socket Head Cap Screw (Mod.)	Select
44	O-ring (Mod. Base)	Select
45	O-ring (Mod. Stop)	Select
46	O-ring (Mod. Seat)	Select
47	O-ring (Mod. Piston Bottom)	Teflon
48	Spring Seal (Piston Bottom)	Teflon
49	Spring Seal (Piston Top)	Teflon

Notes:

1. Standard material is a filter plug. For special materials, vent assembly is supplied.

Pilot Materials (MV)

2900 Series Valve Type 39MV22/72 Pilot

[751 to 6250 psig (51.78 to 430.92 barg)]

39MV22 Pilot Construction

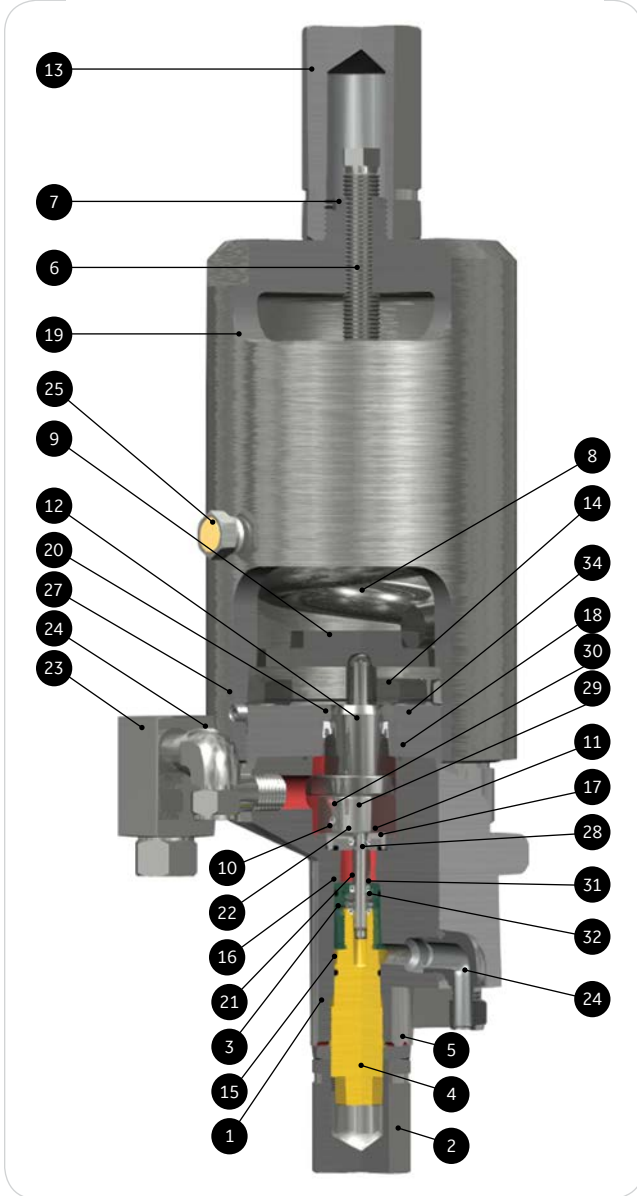

39MV72 Pilot Construction

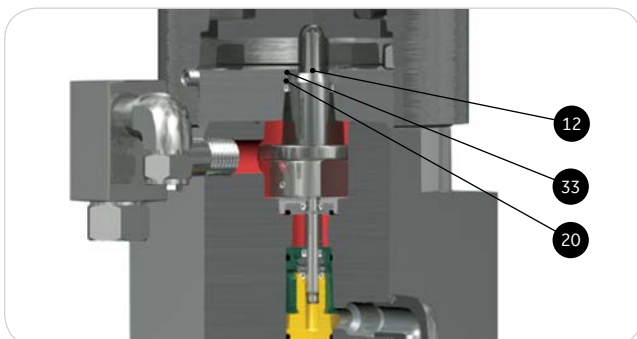

39MV22/72 Pilot Standard Material Variation

Ref. No.	Nomenclature	Material (-CC)
1	Main Base	SA351 Grade CF8M St. St.
2	Adjuster Cap	316 Stainless Steel
3	Adjuster Top	316 Stainless Steel
4	Adjuster Bottom	316 Stainless Steel
5	Adjuster Lock Nut	316 Stainless Steel
6	Compression Screw	316 Stainless Steel
7	Compression Screw Lock Nut	316 Stainless Steel
8	Spring Washer	316 Stainless Steel
9	Spring	Chrome St. (Phosphate Coated)
10	Insert Top	316 Stainless Steel
11	Insert Bottom	316 Stainless Steel
12	Main Piston	316 Stainless Steel
13	Cap (Compression Screw)	316 Stainless Steel
14	Cap Screw (Top Plate)	316 Stainless Steel
15	O-ring (Adjuster Bottom)	Select
16	O-ring (Adjuster Top)	Select
17	O-ring (Insert)	Select
18	O-ring (Top Plate)	Select
19	Bonnet	SA351 Grade CF8M St. St.
20	Spring Seal (Main Piston)	Teflon
21	Spring Seal (Adjuster Top)	Teflon
22	Spring Seal (Insert)	Teflon
23	Field Test Connector	
	Ball	316 Stainless Steel
	Seat O-ring	Select
	Plug O-ring	Select
	Shuttle Base	316 Stainless Steel
	Shuttle Plug	316 Stainless Steel
	Tube Filter	304 Stainless Steel
24	Vent Assembly/Bug Screen (Field Test Connection)	
	Male Elbow	316 Stainless Steel
	Screen	304 Stainless Steel
25	Vent Assembly (Bonnet Vent)1	Nickel Steel/Bronze
27	Set Screw (Bonnet)	316 Stainless Steel
28	Piston Nose	316 Stainless Steel
29	Piston retainer Nut	316 Stainless Steel
30	Set Screw (Piston)	Carbon Steel
31	Vent Seal (Adaptor)	316 Stainless Steel
32	Spring Seal (Vent Seal Adaptor)	Teflon
33	Back-up Ring (39MV72 only)	Rulon 55
34	Top Plate	316 Stainless Steel

Notes:

- Standard material is a filter plug. For special materials, vent assembly is supplied.

Pilot Special Materials (MV)

39MV07 Pilot Standard Material Variation

Alloy 20 Construction

Alloy 20 Construction ^{1,2}		
Part	Construction Variation	
	A1	A4
Main Base, Adjuster Top, Adjuster Bottom	Alloy 20	Alloy 20
Adjuster Cap, Adjuster Lock Nut, Spring Washer	316 Stainless Steel	Alloy 20
Compression Screw, Compression Screw Lock Nut	316 Stainless Steel	Alloy 20
Spring	Chrome Steel (Phosphate Coated)	Inconel X-750
Insert Top, Insert Bottom, Main Piston	Alloy 20	Alloy 20
Cap (Compression Screw), Cap Screw (Top Plate)	316 Stainless Steel	Alloy 20
O-ring (Adjuster Bottom, Adjuster Top, Insert, Top Plate)	Select	Select
Bonnet	SA351 Grade CF8M Stainless Steel	Alloy 20
Spring Seal (Main Piston, Adjuster Top, Insert)	Teflon	Teflon
Field Test Connector		
Ball, Shuttle Base, Shuttle Plug, Tube Filter	Alloy 20	Alloy 20
Seat O-ring, Plug O-ring	Select	Select
Vent Assembly/Bug Screen (Field Test Connection)		
Male Elbow	316 Stainless Steel	Alloy 20
Screen	304 Stainless Steel	304 Stainless Steel
Tube Fittings, Tube Lines, Modulator Base	Alloy 20	Alloy 20
Modulator Stop, Modulator Piston Top, Lock Screw (Retainer)	Alloy 20	Alloy 20
Modulator Piston Bottom, O-ring Retainer	Alloy 20	Alloy 20
Cap Screw (Modulator), Socket Head Cap Screw (Modulator)	316 Stainless Steel	Alloy 20
O-ring (Modulator Base, Modulator Stop)	Select	Select
O-ring (Modulator Seat, Modulator Piston Bottom)	Select	Select
Spring Seal (Piston Bottom, Piston Top)	Teflon	Teflon
Vent Assembly (Bonnet Vent) ³	Nickel Steel/Bronze	
Male Elbow	-	Alloy 20
Screen	-	304 Stainless Steel
Top Plate	Alloy 20	Alloy 20
Set Screw (Bonnet)	316 Stainless Steel	Alloy 20
Lifting Lever Assembly ⁴		
Cam Bushing, Cam Shaft, Lifting Lever	316 Stainless Steel	Alloy 20
Drive Pin	303 Stainless Steel	Alloy 20
Release Nut, Release Locknut	316 Stainless Steel	Alloy 20
Gag Bolt ⁴	316 Stainless Steel	316 Stainless Steel
39MV-3		
Cap (Compression Screw), Sealing Plug, Compression Screw	316 Stainless Steel	Alloy 20
Bonnet, Compression Screw Lock Nut, Top Spring Washer	316 Stainless Steel	Alloy 20
Lower Spring Washer Assembly		
Spring Washer, Lifting Stem	316 Stainless Steel	Alloy 20
Drive Pin	303 Stainless Steel	Alloy 20

Notes:

1. The materials in red denote variation from standard material construction.
2. To specify valves, add material designation to the valve type 39MV/A4.
3. Standard material is a filter plug. For special materials, vent assembly is supplied.
4. 39MV-3 design is required for this option.

Pilot Special Materials (MV)

39MV07 Pilot Material Variation

Duplex Construction

Duplex Construction ^{1,2,3}		
Part	Construction Variation	
	D1	D4
Main Base, Adjuster Top, Adjuster Bottom	Duplex	Duplex
Adjuster Cap, Adjuster Lock Nut, Compression Screw	316 Stainless Steel	Duplex
Compression Screw Lock Nut, Spring Washer	316 Stainless Steel	Duplex
Spring	Chrome Steel (Phosphate Coated)	Inconel X-750
Insert Top, Insert Bottom, Main Piston	Duplex	Duplex
Cap (Compression Screw) , Cap Screw (Top Plate)	316 Stainless Steel	Duplex
O-ring (Adjuster Bottom, Adjuster Top, Insert, Top Plate)	Select	Select
Bonnet	SA351 Grade CF8M Stainless Steel	Duplex
Spring Seal (Main Piston, Adjuster Top, Insert)	Teflon	Teflon
Field Test Connector		
Ball	316 Stainless Steel ⁴	316 Stainless Steel ⁴
Seat O-ring, Plug O-ring	Select	Select
Shuttle Base, Shuttle Plug	Duplex	Duplex
Tube Filter	316 Stainless Steel ⁴	316 Stainless Steel ⁴
Vent Assembly/Bug Screen (Field Test Connection)		
Male Elbow	316 Stainless Steel	Duplex
Screen	304 Stainless Steel	304 Stainless Steel
Tube Fittings, Tube Lines	Duplex ⁵	Duplex ⁵
Modulator Base, Modulator Stop, Modulator Piston Top	Duplex	Duplex
Modulator Piston Bottom, O-ring Retainer, Lock Screw (Retainer)	Duplex	Duplex
Cap Screw (Modulator), Socket Head Cap Screw, Modulator, Modulator Base	316 Stainless Steel	Duplex
Modulator Stop, Modulator Seat, Modulator Piston Bottom	316 Stainless Steel	Duplex
Spring Seal (Piston Bottom, Piston Top)	Teflon	Teflon
Vent Assembly (Bonnet Vent) ⁶	Nickel Steel/Bronze	
Male Elbow	-	Duplex
Screen	-	304 Stainless Steel
Top Plate	Duplex	Duplex
Set Screw (Bonnet)	316 Stainless Steel	Duplex
Lifting Lever Assembly ⁷		
Cam Bushing, Cam Shaft, Lifting Lever, Release Nut, Release Locknut	316 Stainless Steel	Duplex
Drive Pin	303 Stainless Steel	Duplex
Gag Bolt ⁷	316 Stainless Steel	316 Stainless Steel
39MV-3		
Cap (Compression Screw), Compression Screw, Compression Screw Lock Nut	316 Stainless Steel	Duplex
Sealing Plug, Bonnet, Top Spring Washer	316 Stainless Steel	Duplex
Lower Spring Washer Assembly		
Spring Washer, Lifting Stem	316 Stainless Steel	Duplex
Drive Pin	303 Stainless Steel	Duplex

Notes:

1. The materials in red denote variation from standard material construction.
2. To specify valves, add material designation to the valve type 39MV/D4.
3. Parts from casting shall be constructed from ASME SA995 Grade CE8MN Duplex. Parts from barstock shall be constructed from ASME SA479 UNS S31803 Duplex.
4. Cannot get filter or .281" (7.14 mm) ball in Duplex material.
5. All tube fittings and/or valves shall be made from Grade SAF 2507, UNS S32750. Tubes shall be made from ASTM A789, Grade SAF2507, UNS S32750. Do not mix components from other materials with SAF 2507, UNS S32750.
6. Standard material is a filter plug. For special materials, vent assembly is supplied.
7. 39MV-3 design is required for this option.

Pilot Special Materials (MV)

39MV07 Pilot Material Variation

Hastelloy Construction

Hastelloy Construction ^{1,2}		
Part	Construction Variation	
	H1	H4
Main Base	ASME SA494 CW12MW NA	ASME SA494 CW12MW NA
Adjuster Cap, Adjuster Lock Nut, Compression Screw	316 Stainless Steel	Hastelloy
Adjuster Top, Adjuster Bottom, Insert Top, Insert Bottom, Main Piston	Hastelloy	Hastelloy
Compression Screw Lock Nut, Spring Washer	316 Stainless Steel	Hastelloy
Spring	Chrome Steel (Phosphate Coated)	Inconel X-750
Cap (Compression Screw), Cap Screw (Top Plate)	316 Stainless Steel	Hastelloy
O-ring (Adjuster Bottom, Adjuster Top, Insert, Top Plate)	Select	Select
Bonnet	SA351 Grade CF8M St. St.	Hastelloy
Spring Seal (Main Piston, Adjuster Top, Insert)	Teflon	Teflon
Field Test Connector		
Ball, Shuttle Base, Shuttle Plug, Tube Filter	Hastelloy	Hastelloy
Seat O-ring, Plug O-ring	Select	Select
Vent Assembly/Bug Screen (Field Test Connection)		
Male Elbow	316 Stainless Steel	Hastelloy
Screen	304 Stainless Steel	304 Stainless Steel
Tube Fittings, Tube Lines	Hastelloy	Hastelloy
Modulator Base, Modulator Stop	ASME SA494 CW12MW NA	ASME SA494 CW12MW NA
Modulator Piston Top, Modulator Piston Bottom	Hastelloy	Hastelloy
O-ring Retainer, Lock Screw (Retainer), Top Plate	Hastelloy	Hastelloy
Cap Screw (Modulator), Socket Head Cap Screw (Modulator)	316 Stainless Steel	Hastelloy
O-ring (Modulator Base, Modulator Stop, Modulator Piston Bottom)	Select	Select
Spring Seal (Piston Bottom, Piston Top)	Teflon	Teflon
Vent Assembly (Bonnet Vent) ³	Nickel Steel/Bronze	
Male Elbow	-	Hastelloy
Screen	-	304 Stainless Steel
Set Screw (Bonnet)	316 Stainless Steel	Hastelloy
Lifting Lever Assembly ⁴		
Cam Bushing, Cam Shaft, Lifting Lever, Release Nut, Release Locknut	316 Stainless Steel	Hastelloy
Drive Pin	303 Stainless Steel	Hastelloy
Gag Bolt ⁴	316 Stainless Steel	316 Stainless Steel
39MV-3		
Cap (Compression Screw), Sealing Plug, Bonnet, Compression Screw	316 Stainless Steel	Hastelloy
Compression Screw Lock Nut, Top Spring Washer	316 Stainless Steel	Hastelloy
Lower Spring Washer Assembly		
Spring Washer, Lifting Stem	316 Stainless Steel	Hastelloy
Drive Pin	303 Stainless Steel	Hastelloy

Notes:

1. The materials in red denote variation from standard material construction.
2. To specify valves, add material designation to the valve type 39MV/H4.
3. Standard material is a filter plug. For special materials, vent assembly is supplied.
4. 39MV-3 design is required for this option.

Pilot Special Materials (MV)

39MV07 Pilot Material Variation

Monel Construction

Monel Construction ^{1,2}		
Part	Construction Variation	
	M1	M4
Main Base, Modulator Base, Modulator Stop	ASME SA494 M35-1 NCA ³	ASME SA494 M35-1 NCA ³
Adjuster Cap, Adjuster Lock Nut, Compression Screw	316 Stainless Steel	Monel
Adjuster Top, Adjuster Bottom, Insert Top, Insert Bottom, Main Piston	Monel	Monel
Compression Screw Lock Nut, Spring Washer	316 Stainless Steel	Monel
Spring	Chrome Steel (Phosphate Coated)	Inconel X-750
Cap (Compression Screw), Cap Screw (Top Plate), Set Screw (Bonnet)	316 Stainless Steel	Monel
O-ring (Adjuster Bottom, Adjuster Top, Insert, Top Plate)	Select	Select
Bonnet	SA351 Grade CF8M St. St.	Monel
Spring Seal (Main Piston, Adjuster Top, Insert)	Teflon	Teflon
Field Test Connector		
Ball, Shuttle Base, Shuttle Plug, Tube Filter	Monel	Monel
Seat O-ring, Plug O-ring	Select	Select
Vent Assembly/Bug Screen (Field Test Connection)		
Male Elbow	316 Stainless Steel	Monel
Screen	304 Stainless Steel	304 Stainless Steel
Tube Fittings, Tube Lines, Modulator Piston Top, Modulator Piston Bottom	Monel	Monel
O-ring Retainer, Lock Screw (Retainer), Top Plate	Monel	Monel
Cap Screw (Modulator), Socket Head Cap Screw (Modulator)	316 Stainless Steel	316 Stainless Steel
O-ring (Modulator Base, Modulator Stop)	Select	Select
O-ring (Modulator Seat, Modulator Piston Bottom)	Select	Select
Spring Seal (Piston Bottom, Piston Top)	Teflon	Teflon
Vent Assembly (Bonnet Vent) ⁴	Nickel Steel/Bronze	
Male Elbow	-	Monel
Screen	-	304 Stainless Steel
Lifting Lever Assembly ⁵		
Cam Bushing, Cam Shaft, Lifting Lever, Release Nut, Release Locknut	316 Stainless Steel	Monel
Drive Pin	303 Stainless Steel	Monel
Gag Bolt ⁵	316 Stainless Steel	316 Stainless Steel
39MV-3		
Cap (Compression Screw), Sealing Plug, Bonnet, Compression Screw	316 Stainless Steel	Monel
Compression Screw Lock Nut, Top Spring Washer	316 Stainless Steel	Monel
Lower Spring Washer Assembly		
Spring Washer, Lifting Stem	316 Stainless Steel	Monel
Drive Pin	303 Stainless Steel	Monel

Notes:

1. The materials in red denote variation from standard material construction.
2. To specify valves, add material designation to the valve type 39MV/H4.
3. Nickel Copper Alloy (ASME Code Case 1750-22)
4. Standard material is a filter plug. For special materials, vent assembly is supplied.
5. 39MV-3 design is required for this option.

Pilot Special Materials (MV)

39MV07 Pilot Material Variation

Sour Gas Construction

Sour Gas Construction ^{1,2}	
Part	Construction Variation - SG
Main Base, Bonnet	SA351 Grade CF8M St. St.
Adjuster Cap, Adjuster Top, Adjuster Bottom, Adjuster Lock Nut	316 Stainless Steel
Compression Screw, Compression Screw Lock Nut	316 Stainless Steel
Spring Washer	316 Stainless Steel
Spring	Inconel X-750
Insert Top, Insert Bottom, Main Piston	316 Stainless Steel
Cap (Compression Screw), Cap Screw (Top Plate)	316 Stainless Steel
O-ring (Adjuster Bottom, Adjuster Top, Insert, Top Plate)	Select
Spring Seal (Main Piston, Adjuster Top, Insert)	Teflon
Field Test Connector	
Ball, Shuttle Base, Shuttle Plug	316 Stainless Steel
Seat O-ring, Plug O-ring	Select
Tube Filter	304 Stainless Steel
Vent Assembly/Bug Screen (Field Test Connection)	
Male Elbow	316 Stainless Steel
Screen	304 Stainless Steel
Tube Fittings, Tube Lines	316 Stainless Steel
Modulator Base, Modulator Stop	SA351 Grade CF8M St. St.
Modulator Piston Top, Modulator Piston Bottom, O-ring Retainer	316 Stainless Steel
Cap Screw (Modulator), Socket Head Cap Screw (Modulator)	316 Stainless Steel
Lock Screw (Retainer), Top Plate, Set Screw (Bonnet)	316 Stainless Steel
O-ring (Modulator Base, Modulator Stop)	Select
O-ring (Modulator Seat, Modulator Piston Bottom)	Select
Spring Seal (Piston Bottom, Piston Top)	Teflon
Vent Assembly (Bonnet Vent) ³	Nickel Steel/Bronze
Lifting Lever Assembly ⁴	
Cam Bushing, Cam Shaft, Lifting Lever	316 Stainless Steel
Drive Pin	303 Stainless Steel
Release Nut, Release Locknut	316 Stainless Steel
Gag Bolt ⁴	316 Stainless Steel
39MV-3	
Cap (Compression Screw), Sealing Plug, Bonnet	316 Stainless Steel
Compression Screw, Compression Screw Lock Nut	316 Stainless Steel
Top Spring Washer	316 Stainless Steel
Lower Spring Washer Assembly	
Spring Washer, Lifting Stem	316 Stainless Steel
Drive Pin	303 Stainless Steel

Notes:

1. The materials in red denote variation from standard material construction.
2. To specify valves, add material designation to the valve type 39MV/SG.
3. Standard material is a filter plug. For special materials, vent assembly is supplied.
4. 39MV-3 design is required for this option.

Pilot Special Materials (MV)

39MV07 Pilot Dirty Service Material Variation

Dirty Service - Standard & Sour Gas

Dirty Service - Standard & Sour Gas ²		
Part	Dirty Service Material Construction Variation	
	Standard (-CC & -DS)	Sour Gas (-SG & -DS) ¹
Main Base, Bonnet	SA351 Grade CF8M Stainless Steel	SA351 Grade CF8M Stainless Steel
Adjuster Cap, Adjuster Top, Adjuster Bottom, Adjuster Lock Nut	316 Stainless Steel	316 Stainless Steel
Compression Screw, Compression Screw Lock Nut, Spring Washer	316 Stainless Steel	316 Stainless Steel
Spring	Chrome Steel (Phosphate Coated)	Inconel X-750
Insert Top, Insert Bottom		
Clean Service Media (CS), Dirty Service Media (DS)	316 Stainless Steel	316 Stainless Steel
Main Piston, Cap (Compression Screw), Cap Screw (Top Plate)	316 Stainless Steel	316 Stainless Steel
O-ring (Adjuster Bottom, Adjuster Top, Insert, Top Plate)	Select	Select
Spring Seal (Main Piston, Adjuster Top, Insert)	Teflon	Teflon
Field Test Connector		
Ball, Shuttle Base, Shuttle Plug	316 Stainless Steel	316 Stainless Steel
Seat O-ring, Plug O-ring	Select	Select
Tube Filter	304 Stainless Steel	304 Stainless Steel
Vent Assembly/Bug Screen (Field Test Connection)		
Male Elbow	316 Stainless Steel	316 Stainless Steel
Screen	304 Stainless Steel	304 Stainless Steel
Tube Fittings, Bonnet		
Clean Service Media (CS), Dirty Service Media (DS)	316 Stainless Steel	316 Stainless Steel
Modulator Base, Modulator Stop	SA351 Grade CF8M Stainless Steel	SA351 Grade CF8M Stainless Steel
Modulator Piston Top, Modulator Piston Bottom	316 Stainless Steel	316 Stainless Steel
O-ring Retainer, Lock Screw (Retainer), Cap Screw (Modulator)	316 Stainless Steel	316 Stainless Steel
Socket Head Cap Screw (Modulator)	316 Stainless Steel	316 Stainless Steel
O-ring (Modulator Base, Modulator Stop, Modulator Seat)	Select	Select
O-ring (Modulator Piston Bottom)	Select	Select
Spring Seal (Piston Bottom, Piston Top)	Teflon	Teflon
Vent Assembly (Bonnet Vent) ³	Nickel Steel/Bronze	Nickel Steel/Bronze
Top Plate, Set Screw (Bonnet), Dirty Service Insert	316 Stainless Steel	316 Stainless Steel
Regulator	Aluminum/Brass	Aluminum/Brass
Lifting Lever Assembly ⁴		
Cam Bushing, Cam Shaft, Lifting Lever, Release Nut, Release Locknut	316 Stainless Steel	316 Stainless Steel
Drive Pin	303 Stainless Steel	303 Stainless Steel
Gag Bolt ⁴	316 Stainless Steel	316 Stainless Steel
39MV-3		
Cap (Compression Screw), Sealing Plug, Top Spring Washer	316 Stainless Steel	316 Stainless Steel
Bonnet, Compression Screw, Compression Screw Lock Nut	316 Stainless Steel	316 Stainless Steel
Lower Spring Washer Assembly		
Spring Washer, Lifting Stem	316 Stainless Steel	316 Stainless Steel
Drive Pin	303 Stainless Steel	303 Stainless Steel

Notes:

1. The materials in red denote variation from standard material construction.
2. To specify valves, add material designation to the valve type 39MV/CC&DS or 39MV/SG&DS.
3. Standard material is a filter plug. For special materials, vent assembly is supplied.
4. 39MV-3 design is required for this option.

Pilot Special Materials (MV)

39MV07 Pilot Dirty Service Material Variation

Dirty Service - Monel and Hastelloy

Dirty Service - Monel and Hastelloy ^{1,2}		
Part	Dirty Service Material Construction Variation	
	Monel (-M1 & -DS)	Hastelloy (-H1 & -DS)
Main Base, Bonnet	SA351 Grade CF8M Stainless Steel	SA351 Grade CF8M Stainless Steel
Adjuster Cap, Adjuster Top, Adjuster Bottom, Adjuster Lock Nut	316 Stainless Steel	316 Stainless Steel
Compression Screw, Compression Screw Lock Nut, Spring Washer	316 Stainless Steel	316 Stainless Steel
Spring	Chrome Steel (Phosphate Coated)	Chrome Steel (Phosphate Coated)
Insert Top, Insert Bottom		
Clean Service Media (CS)	316 Stainless Steel	316 Stainless Steel
Dirty Service Media (DS)	Monel	Hastelloy
Main Piston	Monel	Hastelloy
Cap (Compression Screw), Cap Screw (Top Plate)	316 Stainless Steel	316 Stainless Steel
O-ring (Adjuster Bottom, Adjuster Top, Insert, Top Plate)	Select	Select
Spring Seal (Main Piston, Adjuster Top, Insert)	Teflon	Teflon
Field Test Connector		
Ball, Shuttle Base, Shuttle Plug, Tube Filter	Monel	Hastelloy
Seat O-ring, Plug O-ring	Select	Select
Vent Assembly/Bug Screen (Field Test Connection)		
Male Elbow	316 Stainless Steel	316 Stainless Steel
Screen	304 Stainless Steel	304 Stainless Steel
Tube Fittings, Tube Lines		
Clean Service Media (CS)	316 Stainless Steel	316 Stainless Steel
Dirty Service Media (DS)	Monel	Hastelloy
Modulator Base, Modulator Stop	SA351 Grade CF8M Stainless Steel	SA351 Grade CF8M Stainless Steel
Modulator Piston Top, Modulator Piston Bottom, O-ring Retainer	316 Stainless Steel	316 Stainless Steel
Lock Screw (Retainer)	316 Stainless Steel	316 Stainless Steel
Cap Screw (Modulator), Socket Head Cap Screw (Modulator)	316 Stainless Steel	316 Stainless Steel
O-ring (Modulator Base, Modulator Stop, Modulator Seat)	Select	Select
O-ring (Modulator Piston Bottom)	Select	Select
Spring Seal (Piston Bottom, Piston Top)	Teflon	Teflon
Vent Assembly (Bonnet Vent) ³	Nickel Steel/Bronze	Nickel Steel/Bronze
Top Plate, Dirty Service Insert	Monel	Hastelloy
Set Screw (Bonnet), Gag Bolt ⁴	316 Stainless Steel	316 Stainless Steel
Regulator	Aluminum/Brass	Aluminum/Brass
Lifting Lever Assembly ⁴		
Cam Bushing, Cam Shaft, Lifting Lever, Release Nut, Release Locknut	316 Stainless Steel	316 Stainless Steel
Drive Pin	303 Stainless Steel	303 Stainless Steel
39PV-3		
Cap (Compression Screw), Sealing Plug, Bonnet, Top Spring Washer	316 Stainless Steel	316 Stainless Steel
Compression Screw, Compression Screw Lock Nut	316 Stainless Steel	316 Stainless Steel
Lower Spring Washer Assembly		
Spring Washer, Lifting Stem	316 Stainless Steel	316 Stainless Steel
Drive Pin	303 Stainless Steel	303 Stainless Steel

Notes:

1. The materials in red denote variation from standard material construction.
2. To specify valves, add material designation to the valve type 39MV/M1&DS or 39MV/H1&DS.
3. Standard material is a filter plug. For special materials, vent assembly is supplied.
4. 39MV-3 design is required for this option.

Pilot Special Materials (MV)

39MV07 Pilot Dirty Service Material Variation

Dirty Service - Duplex & Alloy 20

Dirty Service - Duplex & Alloy 20 ^{1,2}		
Part	Dirty Service Material Construction Variation	
	Duplex (-D1 & -DS) ³	Alloy 20 (-A1 & -DS)
Main Base, Bonnet, Modulator Base, Modulator Stop	SA351 Grade CF8M Stainless Steel	SA351 Grade CF8M Stainless Steel
Adjuster Cap, Adjuster Top, Adjuster Bottom	316 Stainless Steel	316 Stainless Steel
Adjuster Lock Nut, Compression Screw, Cap (Compression Screw)	316 Stainless Steel	316 Stainless Steel
Compression Screw Lock Nut, Spring Washer	316 Stainless Steel	316 Stainless Steel
Spring	Chrome Steel (Phosphate Coated)	Chrome Steel (Phosphate Coated)
Insert Top, Insert Bottom		
Clean Service Media (CS)	316 Stainless Steel	316 Stainless Steel
Dirty Service Media (DS)	Duplex	Alloy 20
Main Piston, Top Plate, Dirty Service Insert	Duplex	Alloy 20
Cap Screw (Top Plate, Adjuster Bottom, Adjuster Top)	316 Stainless Steel	316 Stainless Steel
O-ring (Insert, Top Plate)	Select	Select
Spring Seal (Main Piston, Adjuster Top, Insert)	Teflon	Teflon
Field Test Connector		
Ball	316 Stainless Steel ⁵	Alloy 20
Seat O-ring, Plug O-ring	Select	Select
Shuttle Base, Shuttle Plug	Duplex	Alloy 20
Tube Filter	304 Stainless Steel ⁵	Alloy 20
Vent Assembly/Bug Screen (Field Test Connection)		
Male Elbow	316 Stainless Steel	316 Stainless Steel
Screen	304 Stainless Steel	304 Stainless Steel
Tube Fittings, Tube Lines		
Clean Service Media (CS)	316 Stainless Steel	316 Stainless Steel
Dirty Service Media (DS)	Duplex ⁴	Alloy 20
Modulator Piston Top, Modulator Piston Bottom, Gag Bolt ⁷	316 Stainless Steel	316 Stainless Steel
O-ring Retainer, Lock Screw (Retainer), Cap Screw (Modulator)	316 Stainless Steel	316 Stainless Steel
Socket Head Cap Screw (Modulator), Set Screw (Bonnet)	316 Stainless Steel	316 Stainless Steel
O-ring (Modulator Base, Modulator Stop)	Select	Select
O-ring (Modulator Seat, Modulator Piston Bottom)	Select	Select
Spring Seal (Piston Bottom, Piston Top)	Teflon	Teflon
Vent Assembly (Bonnet Vent) ⁶	Nickel Steel/Bronze	Nickel Steel/Bronze
Regulator	Aluminum/Brass	Aluminum/Brass
Lifting Lever Assembly ⁷		
Cam Bushing, Cam Shaft, Lifting Lever, Drive Pin, Release Nut	316 Stainless Steel	316 Stainless Steel
Release Locknut	316 Stainless Steel	316 Stainless Steel
39MV-3		
Cap (Compression Screw), Sealing Plug, Bonnet, Compression Screw	316 Stainless Steel	316 Stainless Steel
Compression Screw Lock Nut, Top Spring Washer	316 Stainless Steel	316 Stainless Steel
Lower Spring Washer Assembly		
Spring Washer, Lifting Stem	316 Stainless Steel	316 Stainless Steel
Drive Pin	303 Stainless Steel	303 Stainless Steel

Notes:

- The materials in red denote variation from standard material construction.
- To specify valves, add material designation to the valve type 39MV/D1&DS or 39MV/A1&DS.
- Parts from casting shall be constructed from ASME SA995 Grade CE8MN Duplex. Parts from barstock shall be constructed from ASME SA479 UNS S31803 Duplex.
- All tube fittings and/or valves shall be made from Grade SAF 2507, UNS S32750. Tubes shall be made from ASTM A789, Grade SAF2507, UNS S32750. Note: Do not mix components from other materials with SAF 2507, UNS S32750.
- Can not get filter or 9/32 inch ball in Duplex material.
- Standard material is a filter plug. For special materials, vent assembly is supplied.
- 39MV-3 design is required for this option.

Pilot Special Materials (MV)

39MV22/72 Pilot Standard Material Variation

Alloy 20 Construction

Alloy 20 Construction ^{1,2}		
Part	Construction Variation	
	A1	A4
Main Base, Adjuster Top, Adjuster Bottom	Alloy 20	Alloy 20
Adjuster Cap	316 Stainless Steel	Alloy 20
Adjuster Lock Nut, Compression Screw	316 Stainless Steel	Alloy 20
Compression Screw Lock Nut, Spring Washer	316 Stainless Steel	Alloy 20
Spring	Chrome Steel (Phosphate Coated)	Inconel X-750
Insert Top, Insert Bottom, Main Piston	Alloy 20	Alloy 20
Cap (Compression Screw), Cap Screw (Top Plate), Set Screw (Bonnet)	316 Stainless Steel	Alloy 20
O-ring (Adjuster Bottom, Adjuster Top, Insert, Top Plate)	Select	Select
Bonnet	SA351 Grade CF8M Stainless Steel	Alloy 20
Spring Seal (Main Piston, Adjuster Top, Insert)	Teflon	Teflon
Field Test Connector		
Ball, Shuttle Base, Shuttle Plug, Tube Filter	Alloy 20	Alloy 20
Seat O-ring, Plug O-ring	Select	Select
Vent Assembly/Bug Screen (Field Test Connection)		
Male Elbow	316 Stainless Steel	Alloy 20
Screen	304 Stainless Steel	304 Stainless Steel
Vent Assembly (Bonnet Vent) ³	Nickel Steel/Bronze	
Male Elbow	-	Alloy 20
Screen	-	304 Stainless Steel
Piston Nose, Piston Retainer Nut, Set Screw (Piston)	Alloy 20	Alloy 20
Vent Seal (Adaptor), Top Plate, Tube Fittings, Tube Lines	Alloy 20	Alloy 20
Spring Seal (Vent Seal Adaptor)	Teflon	Teflon
Back-up Ring (39MV72 Only)	Rulon 55	Rulon 55
Lifting Lever Assembly ⁴		
Cam Bushing, Cam Shaft, Lifting Lever, Release Nut, Release Locknut	316 Stainless Steel	Alloy 20
Drive Pin	303 Stainless Steel	Alloy 20
Gag Bolt ⁴	316 Stainless Steel	316 Stainless Steel
39MV-3		
Cap (Compression Screw), Sealing Plug, Bonnet, Top Spring Washer	316 Stainless Steel	Alloy 20
Compression Screw, Compression Screw Lock Nut	316 Stainless Steel	Alloy 20
Lower Spring Washer Assembly		
Spring Washer, Lifting Stem	316 Stainless Steel	Alloy 20
Drive Pin	303 Stainless Steel	Alloy 20

Notes:

1. The materials in red denote variation from standard material construction.
2. To specify valves, add material designation to the valve type 39MV22/A4.
3. Standard material is a filter plug. For special materials, vent assembly is supplied.
4. 39MV-3 design is required for this option.

Pilot Special Materials (MV)

39MV22/72 Pilot Material Variation

Duplex Construction

Duplex Construction ^{1,2,3}		
Part	Construction Variation	
	D1	D4
Main Base, Adjuster Top, Adjuster Bottom	Duplex	Duplex
Adjuster Cap, Adjuster Lock Nut, Spring Washer, Compression Screw	316 Stainless Steel	Duplex
Compression Screw Lock Nut, Cap (Compression Screw), Cap Screw (Top Plate)	316 Stainless Steel	Duplex
Spring	Chrome Steel (Phosphate Coated)	Inconel X-750
Insert Top, Insert Bottom, Main Piston	Duplex	Duplex
O-ring (Adjuster Bottom, Adjuster Top, Insert, Top Plate)	Select	Select
Bonnet	SA351 Grade CF8M Stainless Steel	Duplex
Spring Seal (Main Piston, Adjuster Top, Insert), Spring Seal (Vent Seal Adaptor)	Teflon	Teflon
Field Test Connector		
Ball	316 Stainless Steel ⁴	316 Stainless Steel ⁴
Seat O-ring, Plug O-ring	Select	Select
Shuttle Plug, Shuttle Base	Duplex	Duplex
Tube Filter	304 Stainless Steel ⁴	304 Stainless Steel ⁴
Vent Assembly/Bug Screen (Field Test Connection)		
Male Elbow	316 Stainless Steel	Duplex ⁵
Screen	304 Stainless Steel	304 Stainless Steel
Vent Assembly (Bonnet Vent) ⁶	Nickel Steel/Bronze	
Male Elbow	-	Duplex ⁵
Screen	-	Duplex
Set Screw (Bonnet)	316 Stainless Steel	Duplex
Piston Nose, Piston Retainer Nut, Set Screw (Piston), Vent Seal (Adaptor)	Duplex	Duplex
Back-up Ring (39MV72 Only)	Rulon 55	Rulon 55
Top Plate	Duplex	Duplex
Tube Fittings, Tube Lines	Duplex ⁵	Duplex ⁵
Lifting Lever Assembly ⁷		
Cam Bushing, Cam Shaft, Lifting Lever, Release Nut, Release Locknut	316 Stainless Steel	Duplex
Drive Pin	303 Stainless Steel	Duplex
Gag Bolt ⁷	316 Stainless Steel	316 Stainless Steel
39MV-3		
Cap (Compression Screw), Sealing Plug, Bonnet, Top Spring Washer	316 Stainless Steel	Duplex
Compression Screw, Compression Screw Lock Nut	316 Stainless Steel	Duplex
Lower Spring Washer Assembly		
Spring Washer, Lifting Stem	316 Stainless Steel	Duplex
Drive Pin	303 Stainless Steel	Duplex

Notes:

1. The materials in red denote variation from standard material construction.
2. To specify valves, add material designation to the valve type 39MV22/D4.
3. Parts from casting shall be constructed from ASME SA995 Grade CE8MN Duplex. Parts from barstock shall be constructed from ASME SA479 UNS S31803 Duplex.
4. Cannot get filter or .281" (7.14 mm) ball in Duplex material.
5. All tube fittings and/or valves shall be made from Grade SAF 2507, UNS S32750. Tubes shall be made from ASTM A789, Grade SAF2507, UNS S32750. Do not mix components from other materials with SAF 2507, UNS S32750.
6. Standard material is a filter plug. For special materials, vent assembly is supplied.
7. 39MV-3 design is required for this option.

Pilot Special Materials (MV)

39MV22/72 Pilot Material Variation

Hastelloy Construction

Hastelloy Construction ^{1,2}		
Part	Construction Variation	
	H1	H4
Main Base	ASME SA494 CW12MW NA	ASME SA494 CW12MW NA
Adjuster Cap, Adjuster Lock Nut, Compression Screw, Cap Screw (Top Plate)	316 Stainless Steel	Hastelloy
Adjuster Top, Adjuster Bottom, Insert Top, Insert Bottom, Main Piston	Hastelloy	Hastelloy
Compression Screw Lock Nut, Spring Washer, Cap (Compression Screw)	316 Stainless Steel	Hastelloy
Spring	Chrome Steel (Phosphate Coated)	Inconel X-750
O-ring (Adjuster Bottom, Adjuster Top, Insert, Top Plate)	Select	Select
Bonnet	SA351 Grade CF8M St. St.	Hastelloy
Spring Seal (Main Piston, Adjuster Top, Insert), Spring Seal (Vent Seal Adaptor)	Teflon	Teflon
Field Test Connector		
Ball, Shuttle Base, Shuttle Plug, Tube Filter	Hastelloy	Hastelloy
Seat O-ring, Plug O-ring	Select	Select
Vent Assembly/Bug Screen (Field Test Connection)		
Male Elbow	316 Stainless Steel	Hastelloy
Screen	304 Stainless Steel	304 Stainless Steel
Vent Assembly (Bonnet Vent) ³	Nickel Steel/Bronze	
Male Elbow	-	Hastelloy
Screen	-	304 Stainless Steel
Set Screw (Bonnet)	316 Stainless Steel	Hastelloy
Piston Nose, Piston Retainer Nut, Set Screw (Piston), Vent Seal (Adaptor)	Hastelloy	Hastelloy
Back-up Ring (39MV72 Only)	Rulon 55	Rulon 55
Top Plate, Tube Fittings, Tube Lines	Hastelloy	Hastelloy
Lifting Lever Assembly ⁴		
Cam Bushing, Cam Shaft, Lifting Lever, Release Nut, Release Locknut	316 Stainless Steel	Hastelloy
Drive Pin	303 Stainless Steel	Hastelloy
Gag Bolt ⁴	316 Stainless Steel	316 Stainless Steel
39MV-3		
Cap (Compression Screw), Sealing Plug, Bonnet, Top Spring Washer	316 Stainless Steel	Hastelloy
Compression Screw, Compression Screw Lock Nut	316 Stainless Steel	Hastelloy
Lower Spring Washer Assembly		
Spring Washer, Lifting Stem	316 Stainless Steel	Hastelloy
Drive Pin	303 Stainless Steel	Hastelloy

Notes:

1. The materials in red denote variation from standard material construction.
2. To specify valves, add material designation to the valve type 39MV22/H4.
3. Standard material is a filter plug. For special materials, vent assembly is supplied.
4. 39MV-3 design is required for this option.

Pilot Special Materials (MV)

39MV22/72 Pilot Material Variation

Monel Construction

Monel Construction ^{1,2}		
Part	Construction Variation	
	M1	M4
Main Base	ASME SA494 M35-1 NCA ³	ASME SA494 M35-1 NCA ³
Adjuster Cap, Adjuster Lock Nut, Spring Washer, Set Screw (Bonnet)	316 Stainless Steel	Monel
Adjuster Top, Adjuster Bottom, Insert Top, Insert Bottom, Main Piston	Monel	Monel
Compression Screw, Compression Screw Lock Nut	316 Stainless Steel	Monel
Spring	Chrome Steel (Phosphate Coated)	Inconel X-750
Cap (Compression Screw), Cap Screw (Top Plate)	316 Stainless Steel	Monel
O-ring (Adjuster Bottom, Adjuster Top, Insert, Top Plate)	Select	Select
Bonnet	SA351 Grade CF8M St. St.	Monel
Spring Seal (Main Piston, Adjuster Top, Insert), Spring Seal (Vent Seal Adaptor)	Teflon	Teflon
Field Test Connector		
Ball, Shuttle Base, Shuttle Plug, Tube Filter	Monel	Monel
Seat O-ring, Plug O-ring	Select	Select
Vent Assembly/Bug Screen (Field Test Connection)		
Male Elbow	316 Stainless Steel	Monel
Screen	304 Stainless Steel	304 Stainless Steel
Vent Assembly (Bonnet Vent) ⁴	Nickel Steel/Bronze	
Male Elbow	-	Monel
Screen	-	304 Stainless Steel
Piston Nose, Piston Retainer Nut, Set Screw (Piston), Vent Seal (Adaptor)	Monel	Monel
Back-up Ring (39MV72 Only)	Rulon 55	Rulon 55
Top Plate, Tube Fittings, Tube Lines	Monel	Monel
Lifting Lever Assembly ⁵		
Cam Bushing, Cam Shaft, Lifting Lever, Release Nut, Release Locknut	316 Stainless Steel	Monel
Drive Pin	303 Stainless Steel	Monel
Gag Bolt ⁵	316 Stainless Steel	316 Stainless Steel
39MV-3		
Cap (Compression Screw), Sealing Plug, Bonnet, Top Spring Washer	316 Stainless Steel	Monel
Compression Screw, Compression Screw Lock Nut	316 Stainless Steel	Monel
Lower Spring Washer Assembly		
Spring Washer, Lifting Stem	316 Stainless Steel	Monel
Drive Pin	303 Stainless Steel	Monel

Notes:

1. The materials in red denote variation from standard material construction.
2. To specify valves, add material designation to the valve type 39MV/H4.
3. Nickel Copper Alloy (ASME Code Case 1750-22).
4. Standard material is a filter plug. For special materials, vent assembly is supplied.
5. 39MV-3 design is required for this option.

Pilot Special Materials (MV)

39MV22/72 Pilot Material Variation

Sour Gas Construction

Sour Gas Construction ^{1,2}	
Part	Construction Variation - SG
Main Base, Bonnet	SA351 Grade CF8M St. St.
Adjuster Cap, Adjuster Top, Adjuster Bottom, Adjuster Lock Nut	316 Stainless Steel
Compression Screw, Compression Screw Lock Nut	316 Stainless Steel
Spring Washer, Insert Top, Insert Bottom, Main Piston	316 Stainless Steel
Spring	Inconel X-750
Cap (Compression Screw), Cap Screw (Top Plate)	316 Stainless Steel
O-ring (Adjuster Bottom, Adjuster Top, Insert, Top Plate)	Select
Spring Seal (Main Piston, Adjuster Top, Insert)	Teflon
Field Test Connector	
Ball, Shuttle Base, Shuttle Plug	316 Stainless Steel
Seat O-ring, Plug O-ring	Select
Tube Filter	304 Stainless Steel
Vent Assembly/Bug Screen (Field Test Connection)	
Male Elbow	316 Stainless Steel
Screen	304 Stainless Steel
Vent Assembly (Bonnet Vent) ³	Nickel Steel/Bronze
Set Screw (Bonnet), Piston Nose, Piston Retainer Nut	316 Stainless Steel
Set Screw (Piston)	Carbon Steel
Vent Seal (Adaptor), Top Plate, Tube Fittings, Tube Lines	316 Stainless Steel
Spring Seal (Vent Seal Adaptor)	Teflon
Back-up Ring (39MV72 Only)	Rulon 55
Lifting Lever Assembly ⁴	
Cam Bushing, Cam Shaft, Lifting Lever	316 Stainless Steel
Drive Pin	303 Stainless Steel
Release Nut, Release Locknut	316 Stainless Steel
Gag Bolt ⁴	316 Stainless Steel
39MV-3	
Cap (Compression Screw), Sealing Plug, Bonnet	316 Stainless Steel
Compression Screw, Compression Screw Lock Nut	316 Stainless Steel
Top Spring Washer	316 Stainless Steel
Lower Spring Washer Assembly	
Spring Washer, Lifting Stem	316 Stainless Steel
Drive Pin	303 Stainless Steel

Notes:

1. The materials in red denote variation from standard material construction.
2. To specify valves, add material designation to the valve type 39MV22/SG.
3. Standard material is a filter plug. For special materials, vent assembly is supplied.
4. 39MV-3 design is required for this option.

Pilot Design Options

Options and Accessories

Option	Page	Option	Page
Manual Blowdown.....	59	Remote Pilot Mounting.....	60
Field Test Connection.....	59	Dual Pilots.....	60
Filters (Sensing Line, High Capacity & Dual).....	59	Sensing Ring.....	61
Backflow Preventer.....	59	Heat Exchanger.....	62
Pilot Valve Tester.....	60	Dirty Service.....	64
Pressure Differential Switch.....	60		

Manual Blowdown Valve

An optional manual blowdown valve is available for relieving the pilot-operated safety relief valve. Consult the factory for applications requiring a pneumatic or electrical solenoid blowdown valve that may be connected to a distant location, such as an operator station, for remote actuation. Since the blowdown valve is ported directly to the main dome area, the media in the dome is vented when the blowdown valve is actuated, allowing the main valve to open.

For all air, hot water (over 140°F), or steam service applications, ASME Section VIII - Division 1 requires each pressure relief valve to have a lifting device -- such as a blowdown valve -- or a means of connecting or applying pressure to the pilot to verify that the moving parts essential to good operation are free to move. (Reference UG 136(a)(3)).

The lifting lever or blowdown valve may be omitted under Code Case 2203. However, BHGE requires that all orders for pressure relief valves without levers or blowdown valves for steam, air and water over 140°F state specifically that the valves are being purchased per Code Case 2203. The purchaser is responsible for obtaining jurisdictional authorization for use of Code Case 2203.

Field Test Connection

A 1/4" FNPT field test connection is standard on all pilot valve types. This allows the stroking of the valve with an auxiliary media, such as air or nitrogen. An internal check valve that is present in the field test connection isolates the inlet media from the test media while allowing the valve to open normally in the event of a system overpressurization during a field test.

Filters

Filter options are available for dirty applications. These filters are installed in the pilot inlet sensing line. An optional sensing line filter is available for the 39PV and 39MV. This filter, which is standard for steam service, has a 316 stainless steel body, Teflon® seals, and a 40-50-micron stainless steel filter element.

Other high capacity filter options include: (1) a carbon steel filter body with a 35-micron stainless steel element, (2) a stainless steel filter body, and (3) an entirely stainless steel filter arrangement. The O-ring in the filters for steam service will be Teflon®. These filters may be equipped with a manually operated needle valve that allows for purging the filtered material while the valve is in operation.

All filter elements are stainless steel, and all filters, including carbon steel, conform to NACE Standard MR0175.

A dual filter arrangement is available for applications in which the customer is unsure of the filter maintenance requirements. In these cases, a preventive maintenance program may be developed by monitoring the filters without taking the valve off line.

Backflow Preventer

When the pilot-operated safety relief valve is not vented directly to the atmosphere, it is possible to build up back pressure in the discharge line. This is typical in situations where several valves manifold into a common discharge header. Should the discharge line pressure exceed the valve inlet pressure, it could cause the piston to lift and allow reverse flow through the main valve. This situation can be eliminated through the use of the backflow preventer.

Pilot Design Options

Pipe to System Pressure

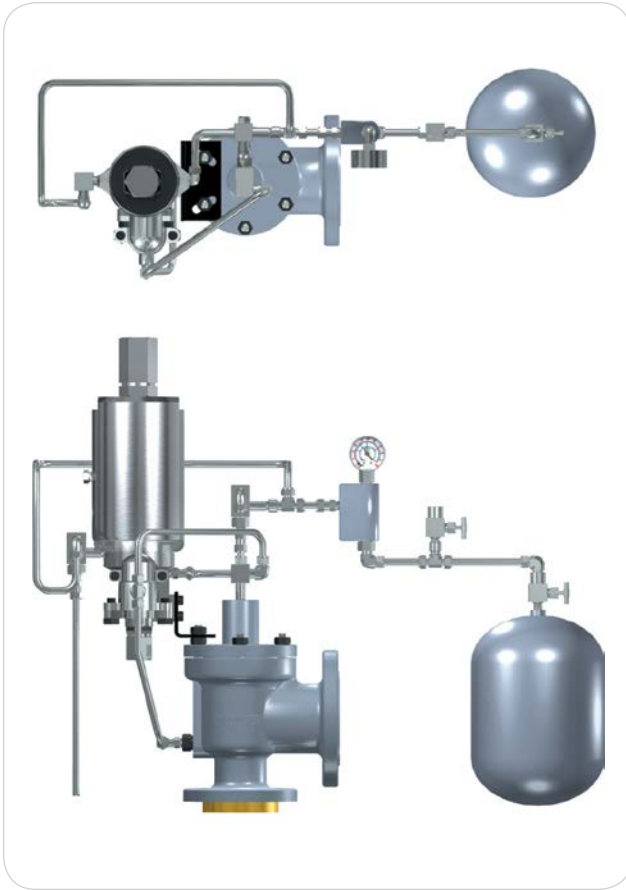

Pilot Valve Tester

The pilot valve test indicator is available for the modulating and pop action pilot valves. The valve test indicator measures the set pressure of the pilot, while maintaining pressure on the main valve dome area, thereby allowing only the pilot to actuate. The system shown at left is available for remote or local testing.

Pressure Differential Switch

Electrical: A pressure differential switch is available that may be wired to an operator station or some other remote location. The switch will provide a signal that indicates when the main valve is opening. The standard pressure differential switch is a single-pole, double-throw, rated at 5 amps and 30 volts DC with a NEMA 4 enclosure. (For other configurations, consult the factory.)

Pneumatic: For applications that do not permit an electrical differential switch, an option is available to provide pneumatic signal to indicate when the main valve opens.

Remote Pilot Mounting

The 39PV and 39MV pilots can be mounted separately from the main valve. Remote pilot mounting will allow heating or cooling the pilot in case ambient conditions are outside the scope of the pilot. It also will enable the user to group several pilots together for control of ambient conditions in a smaller space. In addition, this promotes easier maintenance.

Dual Pilots

A dual pilot arrangement is available for applications in which the pilot valve O-rings require monitoring and/or maintenance more often than the main valve. In this installation, the pilot valves may be alternated for maintenance without bringing the system down.

Notes:

For all option and accessory material variations, contact the factory.

Pilot Design Options

Sensing Ring Option

Remote sensing is the standard pressure connection to the pilot valve used on the 2900 series pilot-operated relief valve. However, with the sensing ring option, the pilot valve pressure can be picked up through a sensing ring located just before the inlet of the main valve.

This is required because the base, unlike the one for the 3900 series pilot-operated safety relief valve, utilizes a through or full nozzle design. As a result of using the through nozzle design, all metal wetted parts in the closed position for the 2900 series valve are made of 316SS material. These parts consist of the sensing ring, nozzle, disc, dome coverplate, dome piston, tubing, and pilot valve. By simply upgrading the base material to 316SS, the valve would become an all-316SS design.

The center-to-face dimensions for a 1900 valve being replaced or converted should be reviewed. The 2900 series center-to-outlet dimension remains the same as a 1900 valve. However, the center-to-outlet dimension increases by 1.5" (38.1 mm) due to the sensing ring requirement. In addition, the thicknesses of two inlet gaskets need to be added. The two gaskets are supplied by the customer and go in between the inlet nozzle flange and the sensing ring and also in between the sensing ring and the system flange.

Notes:

For closed systems where the Takeout dimensions cannot be changed, remote sensing should be used

Pilot Valve with Remote Sensing



Pilot Valve with Inlet Sensing through the Sensing Ring



Pilot Design Options

Heat Exchanger Option

Pilot valves are traditionally limited to the service ranges on the elastomers and Teflon[®] products.

The 2900 series pilot valve, metal seat design, is able to operate at a design temperature above 505°F (262 .8°C) and below -40°F (-40°C) with the use of an air-cooled or air-warmed heat exchanger. For temperatures from 506 to 1200°F (263 to 649°C), or temperatures from -41 to -450°F (-40 .6 to -268°C), consult the factory. The heat exchanger is located upstream of the pilot valve to condition the

temperature of the process fluid to within the acceptable temperature range of the pilot and soft goods (see illustrations below). It is sized to maintain seal integrity, proper valve function and performance. The heat exchanger is sized and selected to meet the service conditions for each application and valve size. The following information is needed to properly size a heat exchanger by a factory engineer:

Heat Exchanger Sizing - Input Form		
Date:		
Customer:		
For Valve Model Number:		
Steam Input Required		
P_1 = Set Pressure		_____ psig _____ barg
Ta max. =	Maximum temperature of ambient air °F ¹	_____ °F _____ °C
Ta min. =	Minimum temperature of ambient air °F ¹	_____ °F _____ °C
T_1 =	Media temperature before it enters the heat exchanger °F	_____ °F _____ °C
T_2 =	Built-up or superimposed backpressure temperature °F if applicable ²	_____ °F _____ °C
Gas and liquid Input Required		
P_1 =	Set Pressure (psig)	_____ psig _____ barg
ρ =	Density of media at inlet conditions lbm/ft ³	_____ lb/ft ³ _____ kg/m ³
C_p =	Specific heat of media at inlet conditions (btu/lbm*°R)	btu/lbm*°R
Ta max. =	Maximum temperature of ambient air °F ¹	_____ °F _____ °C
Ta min. =	Minimum temperature of ambient air °F ¹	_____ °F _____ °C
T_1 =	Media temperature before it enters the heat exchanger °F	_____ °F _____ °C
T_2 =	Built-up or superimposed backpressure temperature °F if applicable ²	_____ °F _____ °C

Notes:

- Over time, the fluid temperature in a Heat Exchanger may approach the ambient temperature. Special consideration should be given to the freezing point of a condensed fluid.
- Special consideration should be given to back pressure temperature to determine if the application can be met.

Pilot Design Options

Heat Exchanger Option

Heat Exchanger with Remote Sensing (Standard)
(High Temperature Configuration)

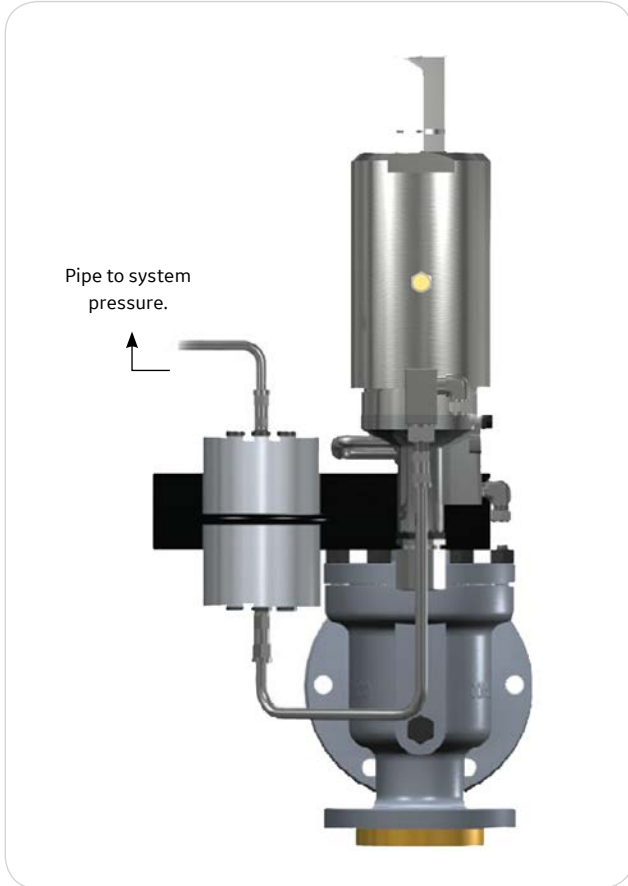

Heat Exchanger and Convection with Sensing Ring
(High Temperature Configuration)



Pilot Design Options

Dirty Service Option

Severe dirty service, precipitation and viscous fluid problems can be solved using the dirty service option offered on the 2900 series POSRV. A dirty service option can be added to the standard pilot valve. The kit contains a 316 SS chamber, an isolation seal and an extended pilot piston. The module is positioned at the top of the pilot valve body and below the pilot valve yoke. Crucial valve components such as the modulator, dome assembly, vent, and inlet seals never come in contact with the dirty system media. The process media pressure still controls the set pressure and blowdown of the POSRV.

For applications requiring the main valve to relieve the dirty fluid, an alternate clean media supply is piped to the pilot. The alternate clean media must be set at the same pressure as the set pressure of the pilot valve, but cannot exceed 3750 psig (258.6 barg), which is the design limit of the pilot valve. In the event that the alternate clean media supply is lost, the main valve will fail in the open position.

For applications requiring the main valve to relieve clean fluid upstream of the dirty process to maintain the dirty process pressure at safe levels, the dirty process pressure is supplied to the dirty service module. The sensing line from the main valve and the connection to the main valve dome is connected to the pilot in the normal manner. The pilot is set to operate at the design pressure of the dirty process. When the dirty process pressure reaches the set-to-open pressure of the pilot, the pilot is stroked by the increase in the dirty

process pressure and the pilot performs the block and bleed operations to effect opening of the main valve. When the dirty process pressure reaches the set-to-close pressure of the pilot, the pilot is stroked by the reduction in the dirty process pressure and the pilot performs the block and bleed operations to effect the closing of the main valve.

The dirty service module is a closed chamber. The flow of dirty process media to the pilot valve is only that volume required to stroke the pilot in response to increasing dirty process pressure. The limited volume of flowing dirty media entering the pilot makes plugging of the module an unlikely possibility. However, if plugging of the module is a concern, the module can be filled with a compatible clean liquid and a siphon tube can be fitted in the connection line between the pilot module and the dirty process. The dirty service option can provide some cost savings in material selection for corrosive service. It is possible that only the material of construction for the dirty service option will need to be upgraded. The remaining parts in contact with clean media could use standard materials of construction.

Notes:

For special material options on the dirty service option consult the factory.

Pilot Design Options

Dirty Service Option

MPV Dirty Service Pilot

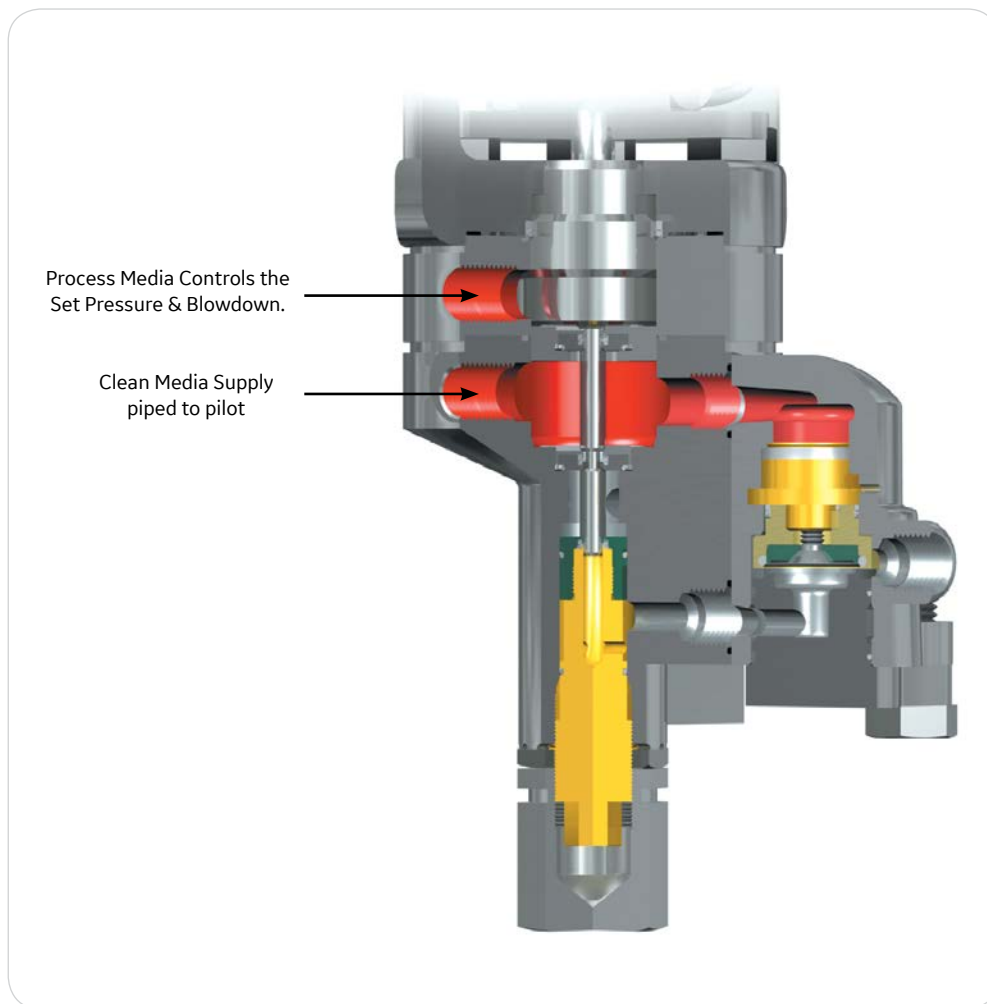

Piping Configurations

Alternate Piping Arrangements

39 PV with Pilot Valve Vented to Atmosphere

Standard Field Test Connection	67
Manual Blowdown	67
Pilot Supply Filter.....	68
Backflow Preventer	68
Manual Blowdown and Pilot Supply Filter	69
Backflow Preventer, Manual Blowdown, and Pilot Supply Filter	69

39 MV with Pilot Valve Vented to Atmosphere

Standard Field Test Connection	70
Manual Blowdown	70
Pilot Supply Filter	71
Backflow Preventer	71
Manual Blowdown and Pilot Supply Filter.....	72
Backflow Preventer, Manual Blowdown, and Pilot Supply Filter	72

39 PV with Pilot Valve Vented to Body Bowl

Standard Field Test Connection	73
Manual Blowdown	73
Pilot Supply Filter.....	74
Backflow Preventer	74
Manual Blowdown and Pilot Supply Filter.....	75
Backflow Preventer, Manual Blowdown, and Pilot Supply Filter	75

39 MV with Pilot Valve Vented to Body Bowl

Standard Field Test Connection	76
Manual Blowdown	76
Pilot Supply Filter	77
Backflow Preventer	77
Manual Blowdown and Pilot Supply Filter	78
Backflow Preventer, Manual Blowdown, and Pilot Supply Filter	78
Manual Blowdown, Pilot Supply Filter, and Heat Exchanger for Hot Service	79
Manual Blowdown, Pilot Supply Filter, and Heat Exchanger for Cold Service	80

Piping Configurations

2900 Series Type 39PV Pop Pilot (Vented to Atmosphere)

Pilot Valve with Standard Field Test Connection
(Standard for all Media Applications)

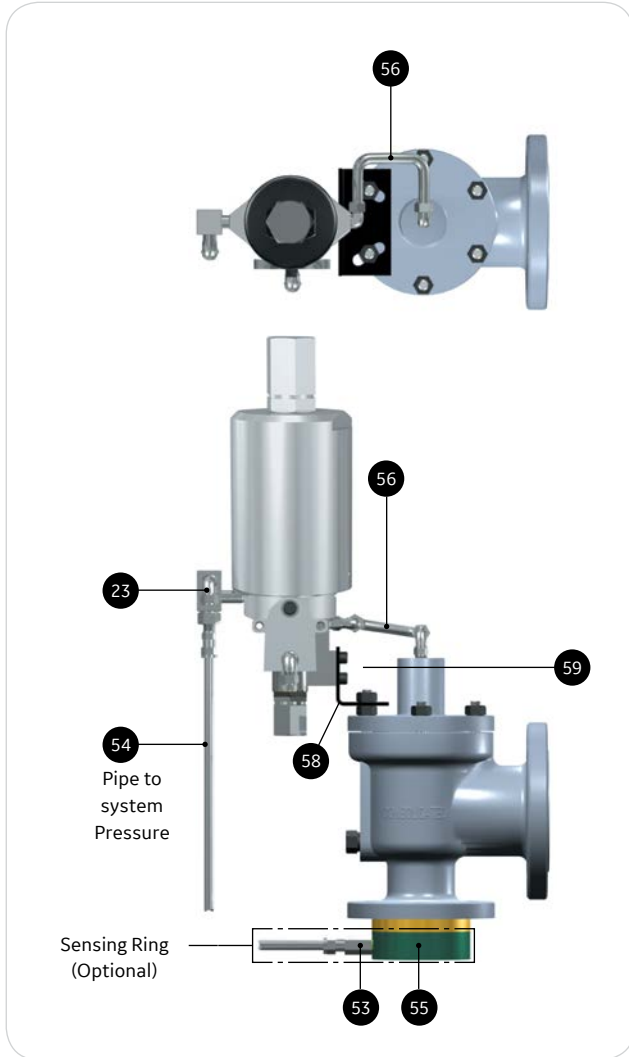

Pilot Valve with Manual Blowdown
(Optional for all Media Applications)

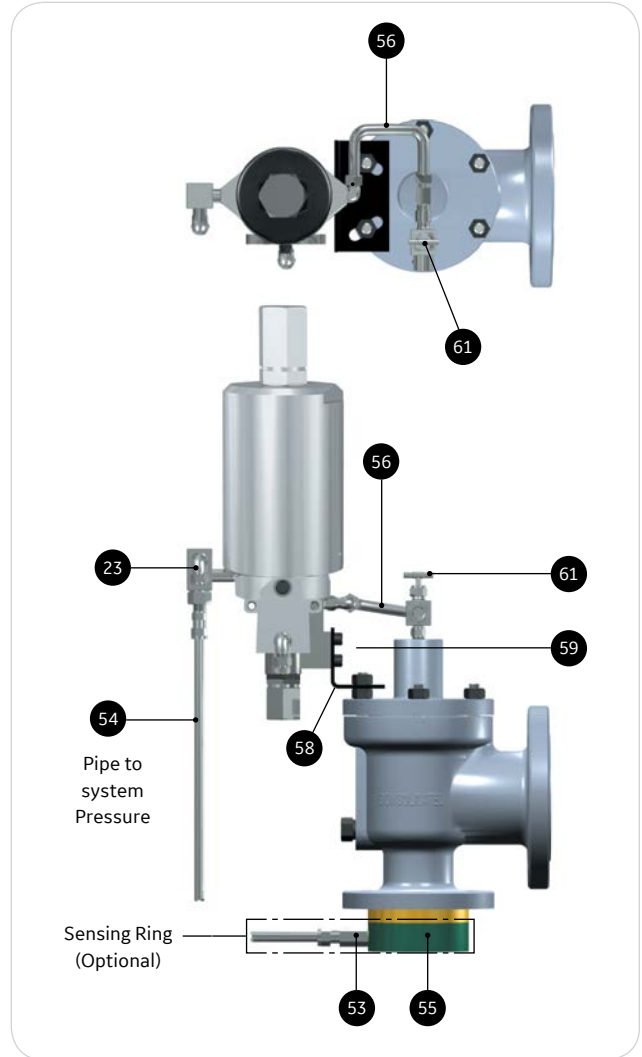

Pilot Valve with Standard Field Test Connection (Standard for all Media Applications)		
	Part	Material
23	Field Test Connection	316 Stainless Steel
53	Sensing Tube	316 Stainless Steel
54	Sensing Line	316 Stainless Steel
55	Sensing Ring	316 Stainless Steel
56	Dome Line	316 Stainless Steel
58	Bracket	Carbon Steel
59	Bracket Cap Screw	316 Stainless Steel

Pilot Valve with Manual Blowdown (Optional for all Media Applications)		
	Part	Material
23	Field Test Connection	316 Stainless Steel
53	Sensing Tube	316 Stainless Steel
54	Sensing Line	316 Stainless Steel
55	Sensing Ring	316 Stainless Steel
56	Dome Line	316 Stainless Steel
58	Bracket	Carbon Steel
59	Bracket Cap Screw	316 Stainless Steel
61	Needle Valve (Manual Blowdown)	316 Stainless Steel

Piping Configurations

2900 Series Type 39PV Pop Pilot (Vented to Atmosphere)

Pilot Valve with Pilot Supply Filter
(Optional for all Media Applications)

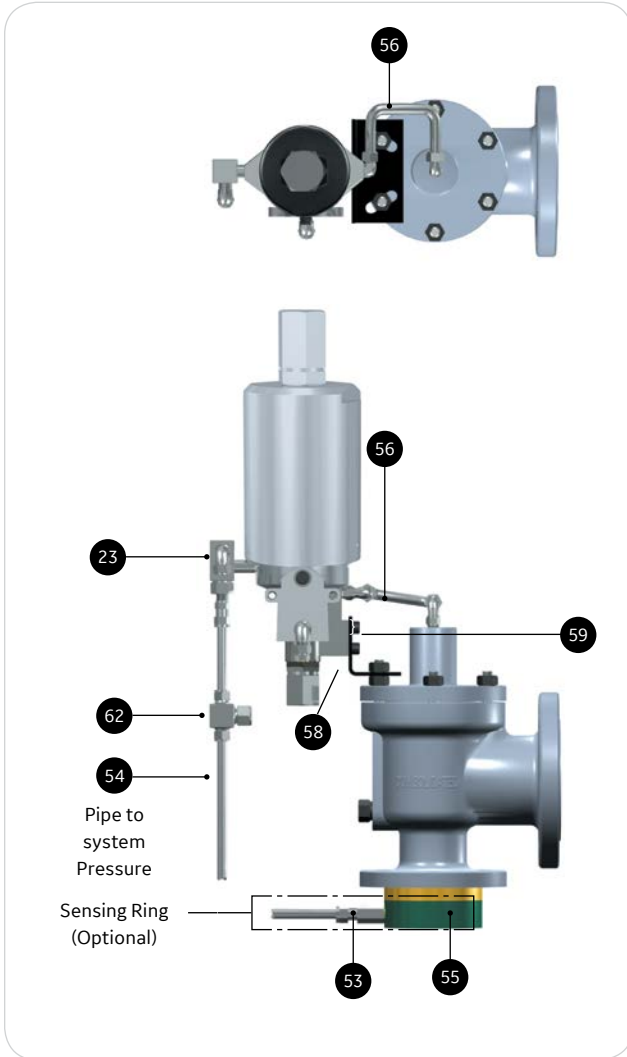

Pilot Valve with Backflow Preventer
(Optional for Liquid and Gas Applications)

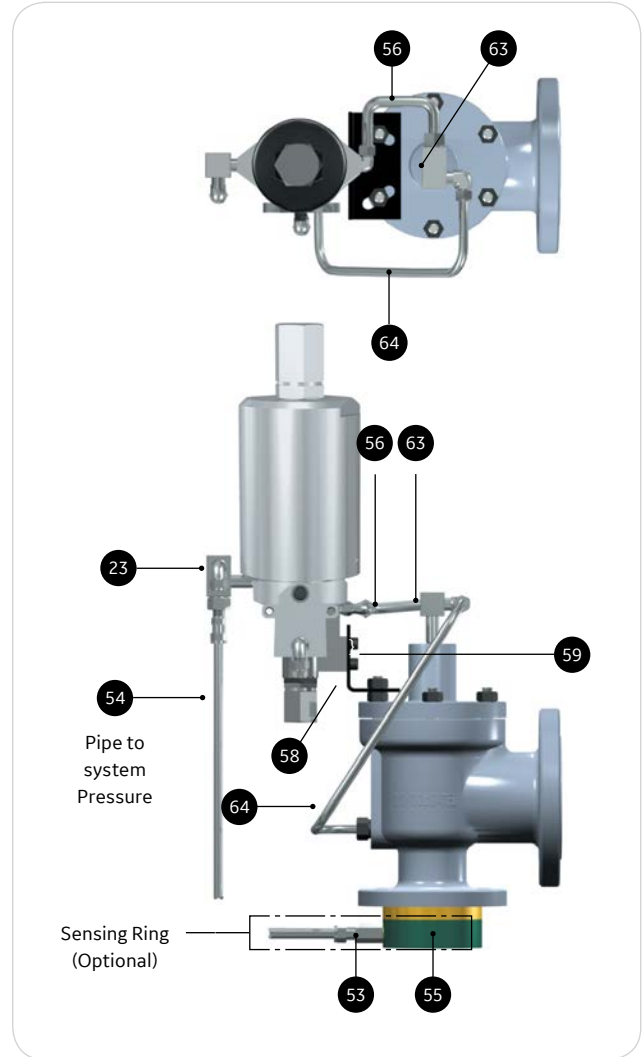

Pilot Valve with Pilot Supply Filter (Optional for all Media Applications)		
	Part	Material
23	Field Test Connection	316 Stainless Steel
53	Sensing Tube	316 Stainless Steel
54	Sensing Line	316 Stainless Steel
55	Sensing Ring	316 Stainless Steel
56	Dome Line	316 Stainless Steel
58	Bracket	Carbon Steel
59	Bracket Cap Screw	316 Stainless Steel
62	Pilot Supply Filter	316 Stainless Steel

Pilot Valve with Backflow Preventer (Optional for Liquid and Gas Applications)		
	Part	Material
23	Field Test Connection	316 Stainless Steel
53	Sensing Tube	316 Stainless Steel
54	Sensing Line	316 Stainless Steel
55	Sensing Ring	316 Stainless Steel
56	Dome Line	316 Stainless Steel
58	Bracket	Carbon Steel
59	Bracket Cap Screw	316 Stainless Steel
63	Backflow Preventer	316 Stainless Steel
64	Backflow Preventer Line	316 Stainless Steel

Piping Configurations

2900 Series Type 39PV Pop Pilot (Vented to Atmosphere)

Pilot Valve with Manual Blowdown & Pilot Supply Filter
(Standard for Steam Applications)
(Optional for Liquid & Gas Applications)

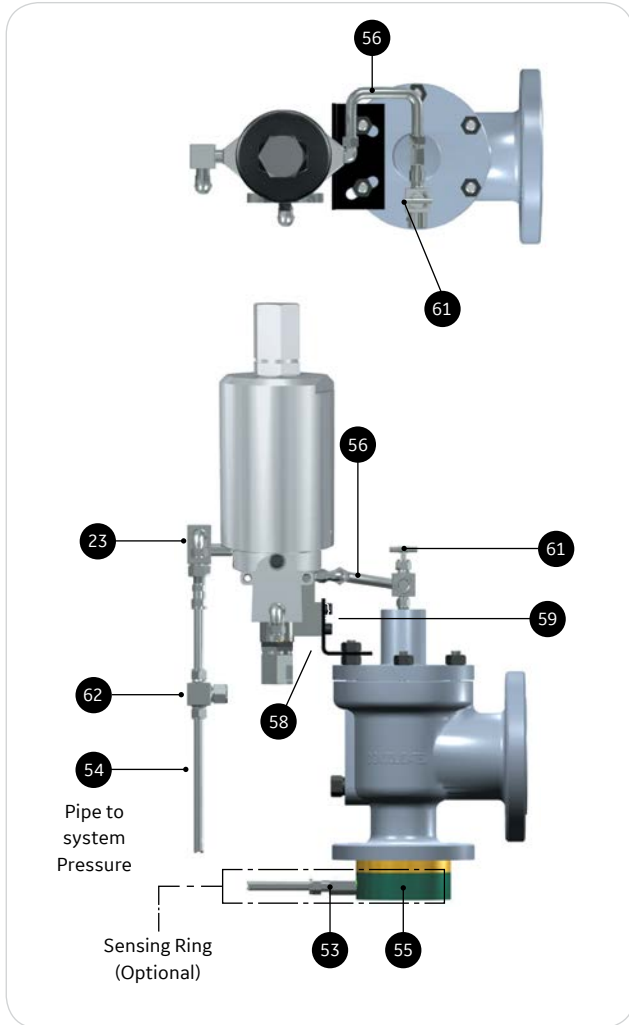

Pilot Valve with Backflow Preventer,
Manual Blowdown and Pilot Supply Filter
(Optional for Steam Applications)

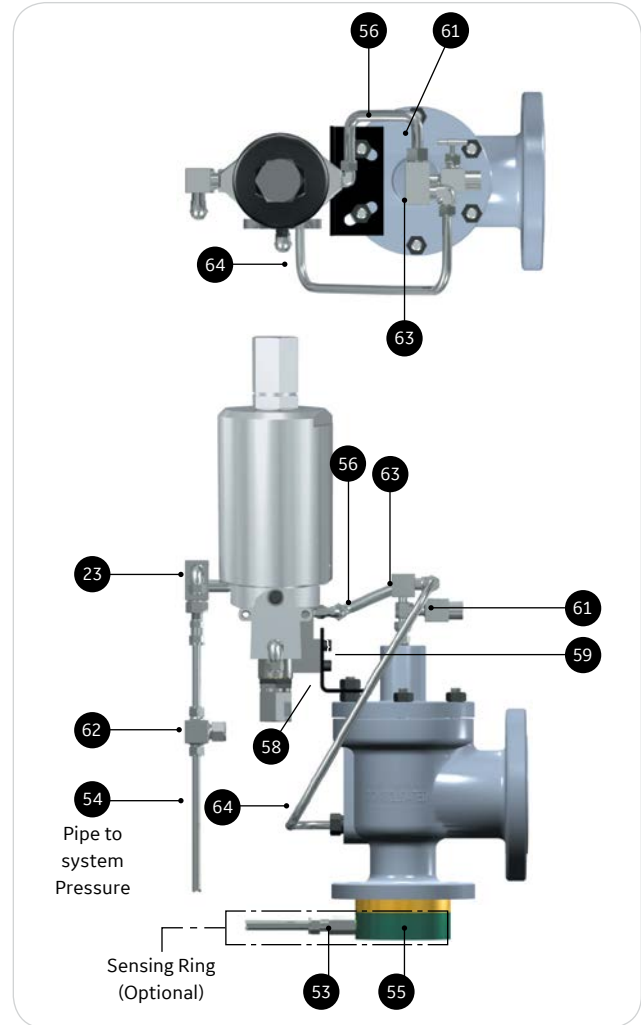

Pilot Valve with Manual Blowdown & Pilot Supply Filter
(Standard for Steam Applications)
(Optional for Liquid & Gas Applications)

	Part	Material
23	Field Test Connection	316 Stainless Steel
53	Sensing Tube	316 Stainless Steel
54	Sensing Line	316 Stainless Steel
55	Sensing Ring	316 Stainless Steel
56	Dome Line	316 Stainless Steel
58	Bracket	Carbon Steel
59	Bracket Cap Screw	316 Stainless Steel
61	Needle Valve (Manual Blowdown)	316 Stainless Steel
62	Pilot Supply Filter	316 Stainless Steel

Pilot Valve with Backflow Preventer, Manual Blowdown and Pilot Supply Filter (Optional for Steam Applications)

	Part	Material
23	Field Test Connection	316 Stainless Steel
53	Sensing Tube	316 Stainless Steel
54	Sensing Line	316 Stainless Steel
55	Sensing Ring	316 Stainless Steel
56	Dome Line	316 Stainless Steel
58	Bracket	Carbon Steel
59	Bracket Cap Screw	316 Stainless Steel
61	Needle Valve (Manual Blowdown)	316 Stainless Steel
62	Pilot Supply Filter	316 Stainless Steel
63	Backflow Preventer	316 Stainless Steel
64	Backflow Preventer Line	316 Stainless Steel

Piping Configurations

2900 Series Type 39MV Modulating Pilot (Vented to Atmosphere)

Pilot Valve with Standard Field Test Connection
(Standard for all Media Applications)

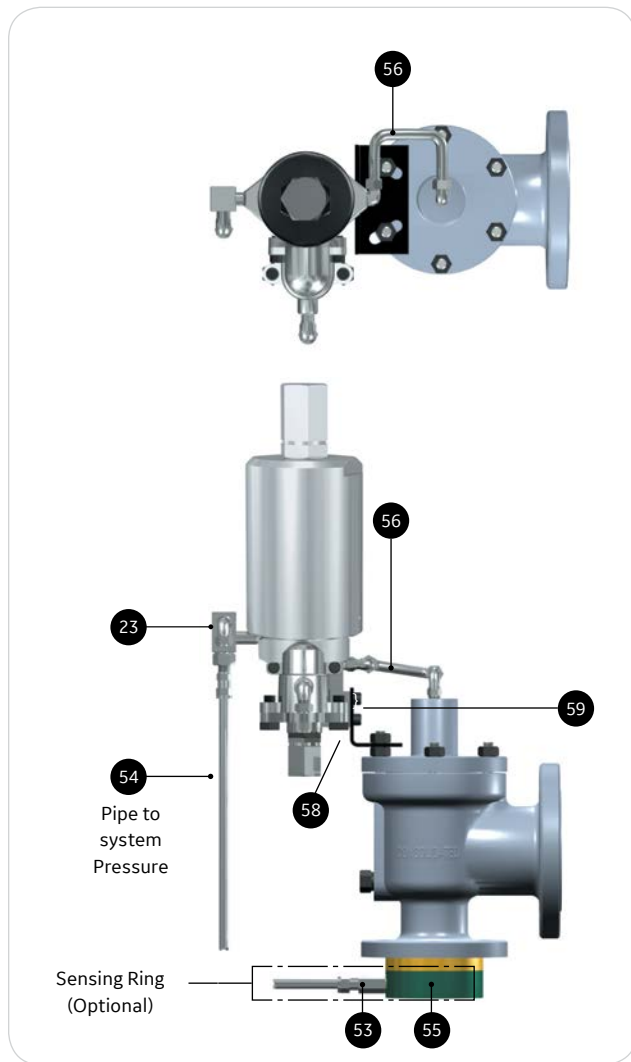

Pilot Valve with Manual Blowdown
(Optional for all Media Applications)

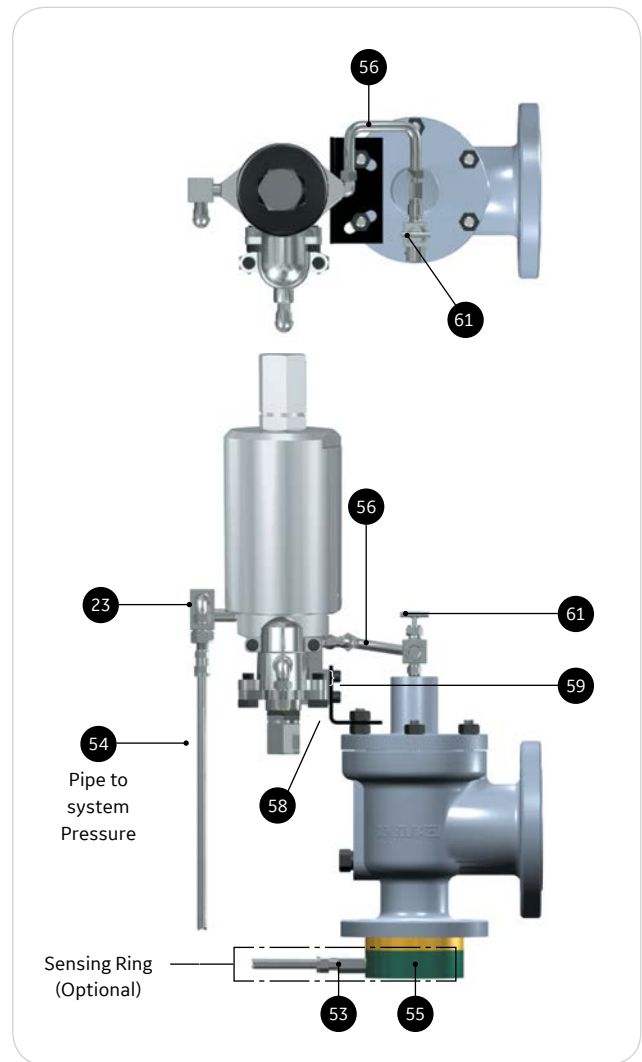

Pilot Valve with Standard Field Test Connection
(Standard for all Media Applications)

	Part	Material
23	Field Test Connection	316 Stainless Steel
53	Sensing Tube	316 Stainless Steel
54	Sensing Line	316 Stainless Steel
55	Sensing Ring	316 Stainless Steel
56	Dome Line	316 Stainless Steel
58	Bracket	Carbon Steel
59	Bracket Cap Screw	316 Stainless Steel

Pilot Valve with Manual Blowdown
(Optional for all Media Applications)

	Part	Material
23	Field Test Connection	316 Stainless Steel
53	Sensing Tube	316 Stainless Steel
54	Sensing Line	316 Stainless Steel
55	Sensing Ring	316 Stainless Steel
56	Dome Line	316 Stainless Steel
58	Bracket	Carbon Steel
59	Bracket Cap Screw	316 Stainless Steel
61	Needle Valve (Manual Blowdown)	316 Stainless Steel

Piping Configurations

2900 Series Type 39MV Modulating Pilot (Vented to Atmosphere)

Pilot Valve with Pilot Supply Filter
(Optional for all Media Applications)

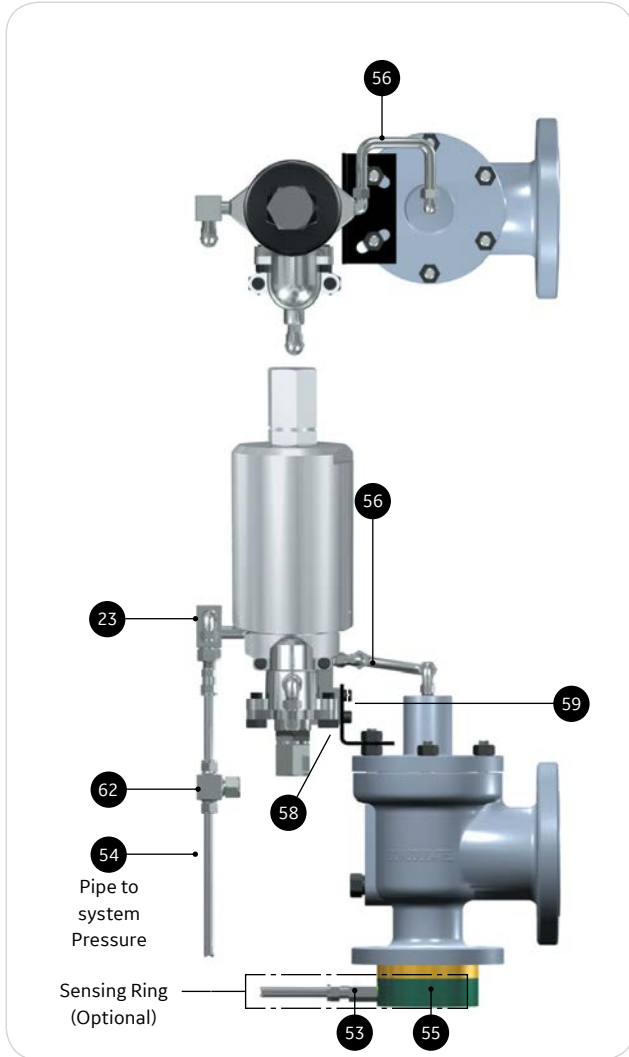

Pilot Valve with Backflow Preventer
(Optional for Liquid & Gas Applications)

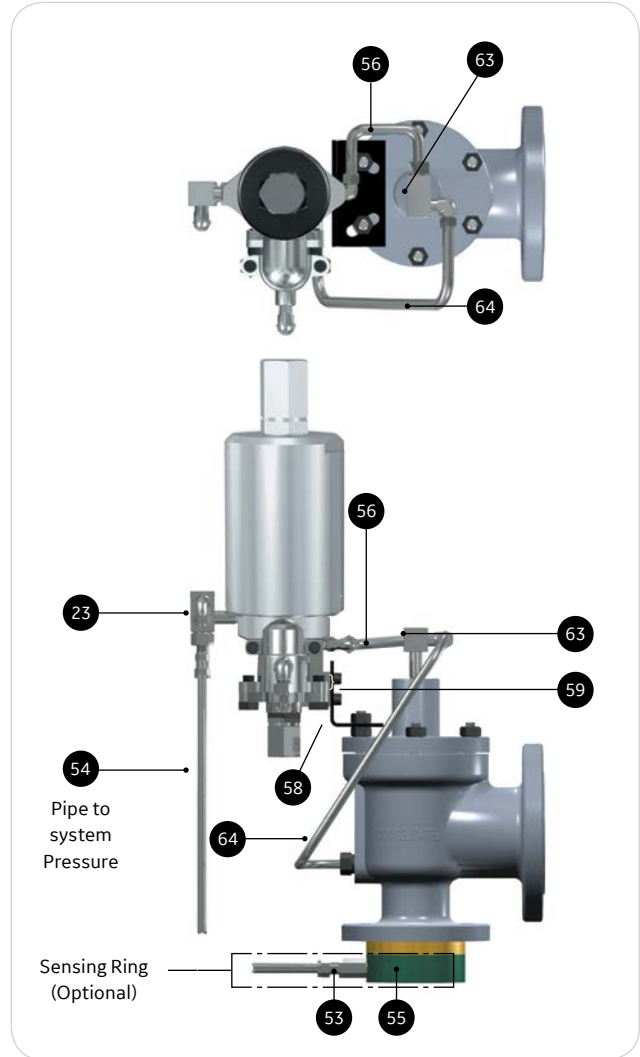

Pilot Valve with Pilot Supply Filter (Optional for all Media Applications)		
	Part	Material
23	Field Test Connection	316 Stainless Steel
53	Sensing Tube	316 Stainless Steel
54	Sensing Line	316 Stainless Steel
55	Sensing Ring	316 Stainless Steel
56	Dome Line	316 Stainless Steel
58	Bracket	Carbon Steel
59	Bracket Cap Screw	316 Stainless Steel
62	Pilot Supply Filter	316 Stainless Steel

Pilot Valve with Backflow Preventer (Optional for Liquid & Gas Applications)		
	Part	Material
23	Field Test Connection	316 Stainless Steel
53	Sensing Tube	316 Stainless Steel
54	Sensing Line	316 Stainless Steel
55	Sensing Ring	316 Stainless Steel
56	Dome Line	316 Stainless Steel
58	Bracket	Carbon Steel
59	Bracket Cap	Screw 316 Stainless Steel
63	Backflow Preventer	316 Stainless Steel
64	Backflow Preventer Line	316 Stainless Steel

Piping Configurations

2900 Series Type 39MV Modulating Pilot

(Vented to Atmosphere)

Pilot Valve with Manual Blowdown & Pilot Supply Filter
(Standard for Steam Applications)
(Optional for Liquid & Gas Applications)

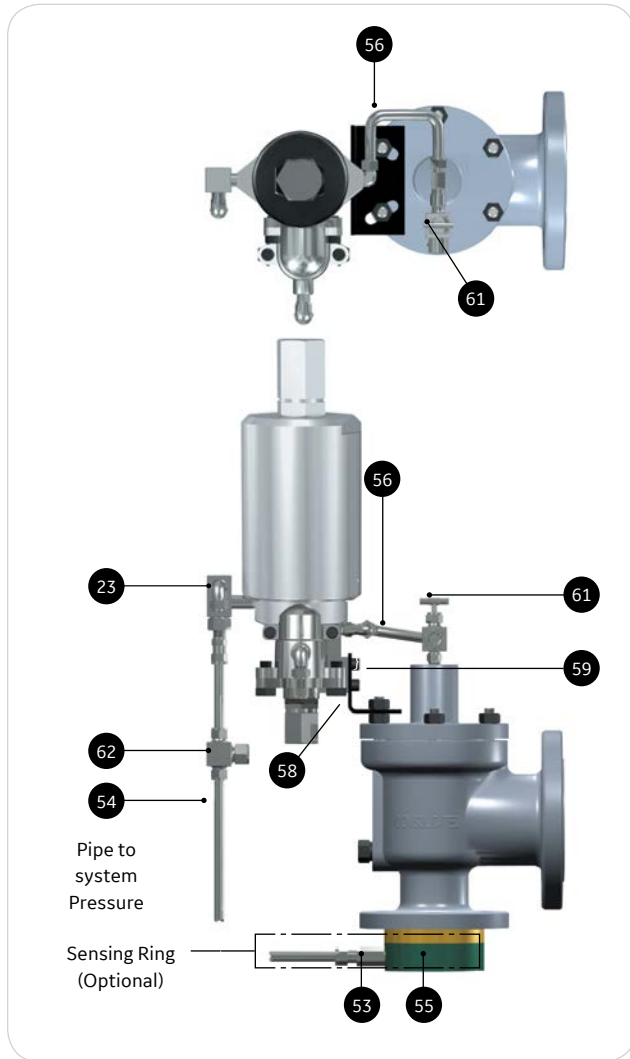

Pilot Valve with Backflow Preventer,
Manual Blowdown and Pilot Supply Filter
(Optional for Steam Applications)

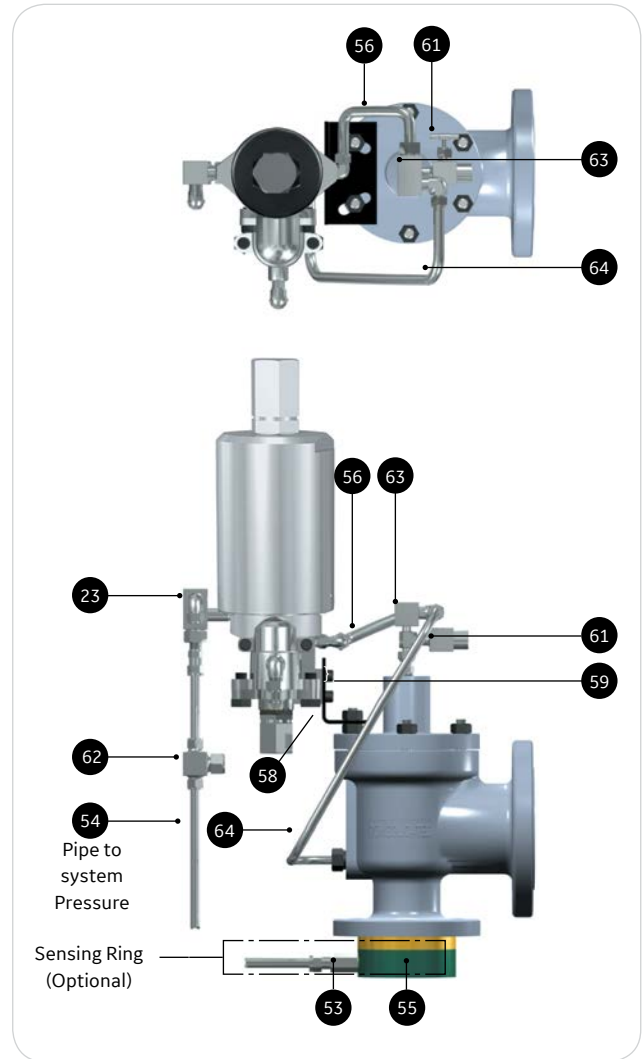

Pilot Valve with Manual Blowdown & Pilot Supply Filter
(Standard for Steam Applications)
(Optional for Liquid & Gas Applications)

	Part	Material
23	Field Test Connection	316 Stainless Steel
53	Sensing Tube	316 Stainless Steel
54	Sensing Line	316 Stainless Steel
55	Sensing Ring	316 Stainless Steel
56	Dome Line	316 Stainless Steel
58	Bracket	Carbon Steel
59	Bracket Cap Screw	316 Stainless Steel
61	Needle Valve (Manual Blowdown)	316 Stainless Steel
62	Pilot Supply Filter	316 Stainless Steel

Pilot Valve with Backflow Preventer,
Manual Blowdown and Pilot Supply Filter
(Optional for Steam Applications)

	Part	Material
23	Field Test Connection	316 Stainless Steel
53	Sensing Tube	316 Stainless Steel
54	Sensing Line	316 Stainless Steel
55	Sensing Ring	316 Stainless Steel
56	Dome Line	316 Stainless Steel
58	Bracket	Carbon Steel
59	Bracket Cap Screw	316 Stainless Steel
61	Needle Valve (Manual Blowdown)	316 Stainless Steel
62	Pilot Supply Filter	316 Stainless Steel
63	Backflow Preventer	316 Stainless Steel
64	Backflow Preventer Line	316 Stainless Steel

Piping Configurations

2900 Series Type 39PV Pop Pilot

(Vented to Body Bowl)

Pilot Valve with Standard Field Test Connector
(Standard for all Media Applications)

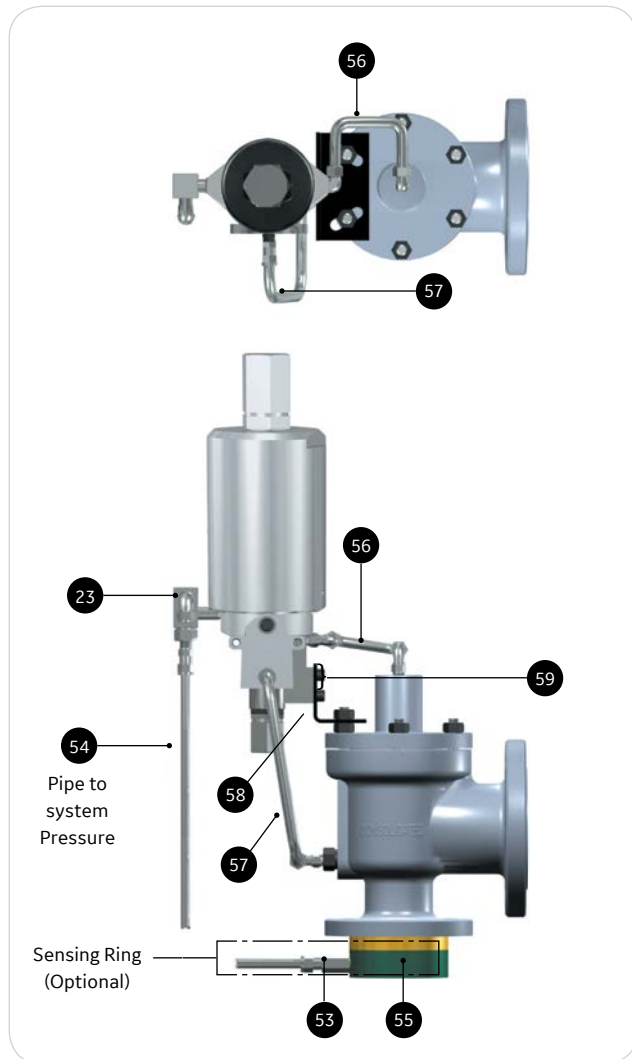

Pilot Valve with Manual Blowdown
(Optional for all Media Applications)

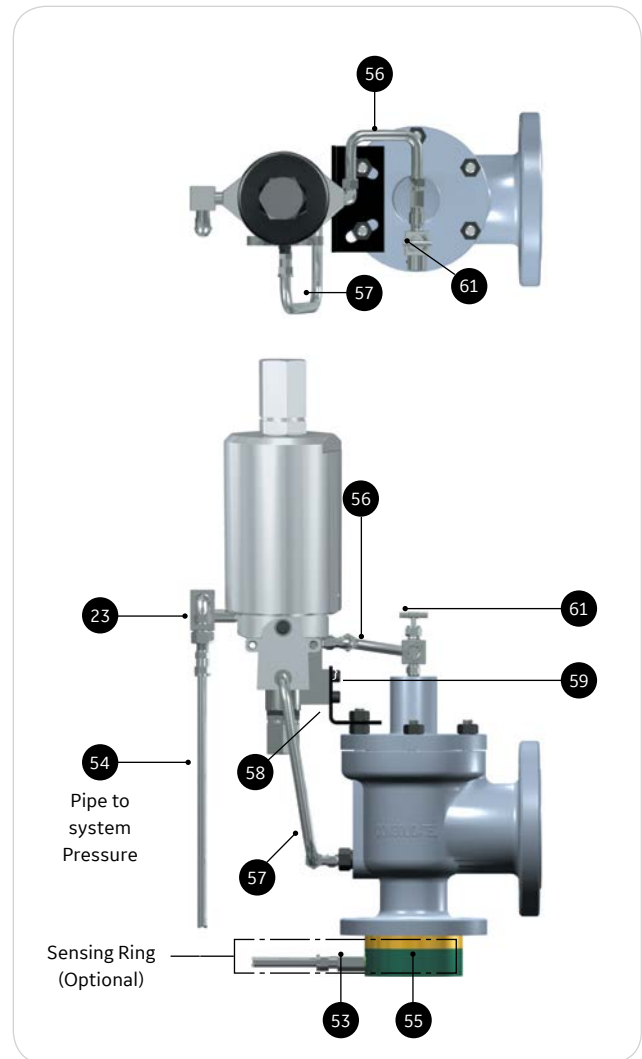

Pilot Valve with Standard Field Test Connection
(Standard for all Media Applications)

	Part	Material
23	Field Test Connection	316 Stainless Steel
53	Sensing Tube	316 Stainless Steel
54	Sensing Line	316 Stainless Steel
55	Sensing Ring	316 Stainless Steel
56	Dome Line	316 Stainless Steel
57	Discharge Line	316 Stainless Steel
58	Bracket	Carbon Steel
59	Bracket Cap Screw	316 Stainless Steel

Pilot Valve with Manual Blowdown
(Optional for all Media Applications)

	Part	Material
23	Field Test Connection	316 Stainless Steel
53	Sensing Tube	316 Stainless Steel
54	Sensing Line	316 Stainless Steel
55	Sensing Ring	316 Stainless Steel
56	Dome Line	316 Stainless Steel
57	Discharge Line	316 Stainless Steel
58	Bracket	Carbon Steel
59	Bracket Cap Screw	316 Stainless Steel
61	Needle Valve (Manual Blowdown)	316 Stainless Steel

Piping Configurations

2900 Series Type 39PV Pop Pilot (Vented to Body Bowl)

Pilot Valve with Pilot Supply Filter
(Optional for all Media Applications)

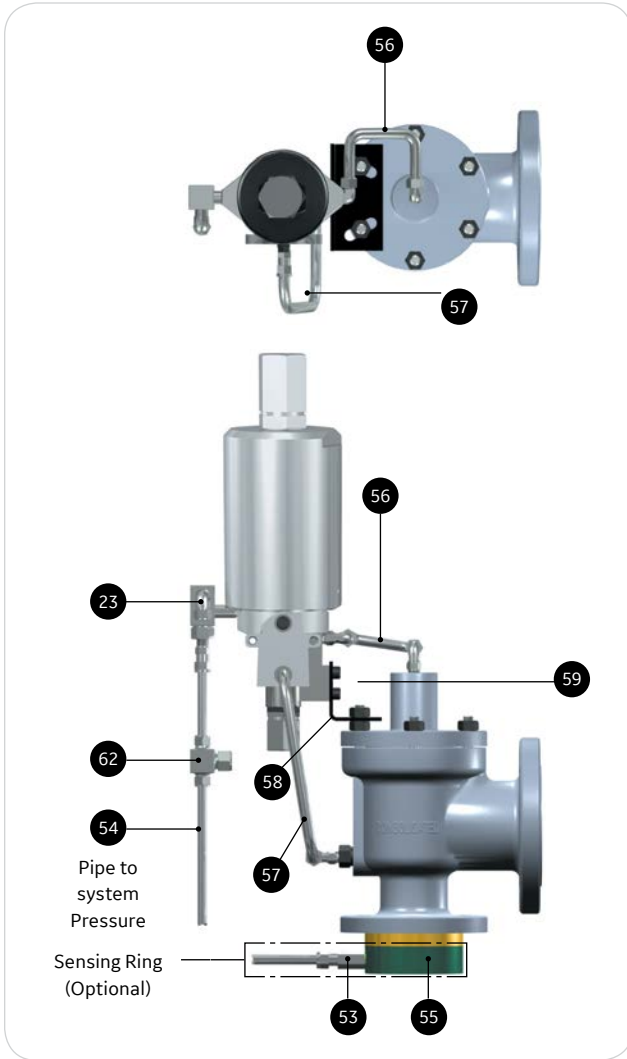

Pilot Valve with Backflow Preventer
(Optional for all Liquid & Gas Applications)

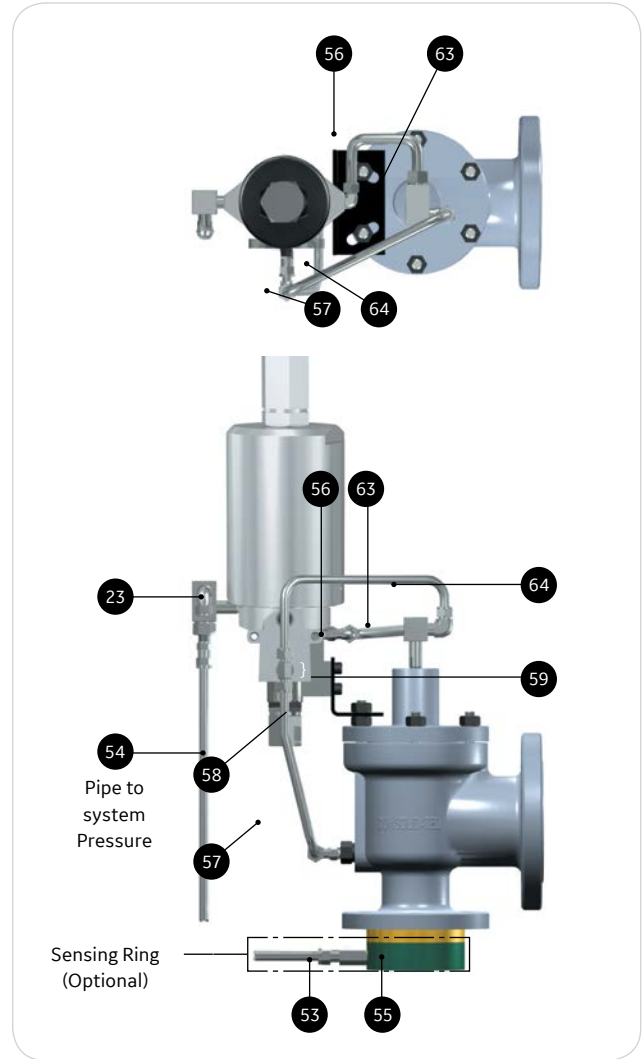

Pilot Valve with Pilot Supply Filter
(Optional for all Media Applications)

	Part	Material
23	Field Test Connection	316 Stainless Steel
53	Sensing Tube	316 Stainless Steel
54	Sensing Line	316 Stainless Steel
55	Sensing Ring	316 Stainless Steel
56	Dome Line	316 Stainless Steel
57	Discharge Line	316 Stainless Steel
58	Bracket	Carbon Steel
59	Bracket Cap Screw	316 Stainless Steel
62	Pilot Supply Filter	316 Stainless Steel

Pilot Valve with Backflow Preventer
(Optional for all Liquid & Gas Applications)

	Part	Material
23	Field Test Connection	316 Stainless Steel
53	Sensing Tube	316 Stainless Steel
54	Sensing Line	316 Stainless Steel
55	Sensing Ring	316 Stainless Steel
56	Dome Line	316 Stainless Steel
57	Discharge Line	316 Stainless Steel
58	Bracket	Carbon Steel
59	Bracket Cap Screw	316 Stainless Steel
63	Backflow Preventer	316 Stainless Steel
64	Backflow Preventer Line	316 Stainless Steel

Piping Configurations

2900 Series Type 39PV Pop Pilot

(Vented to Body Bowl)

Pilot Valve with Manual Blowdown and Pilot Supply Filter
(Standard for Steam Applications)
(Optional for Liquid & Gas Applications)

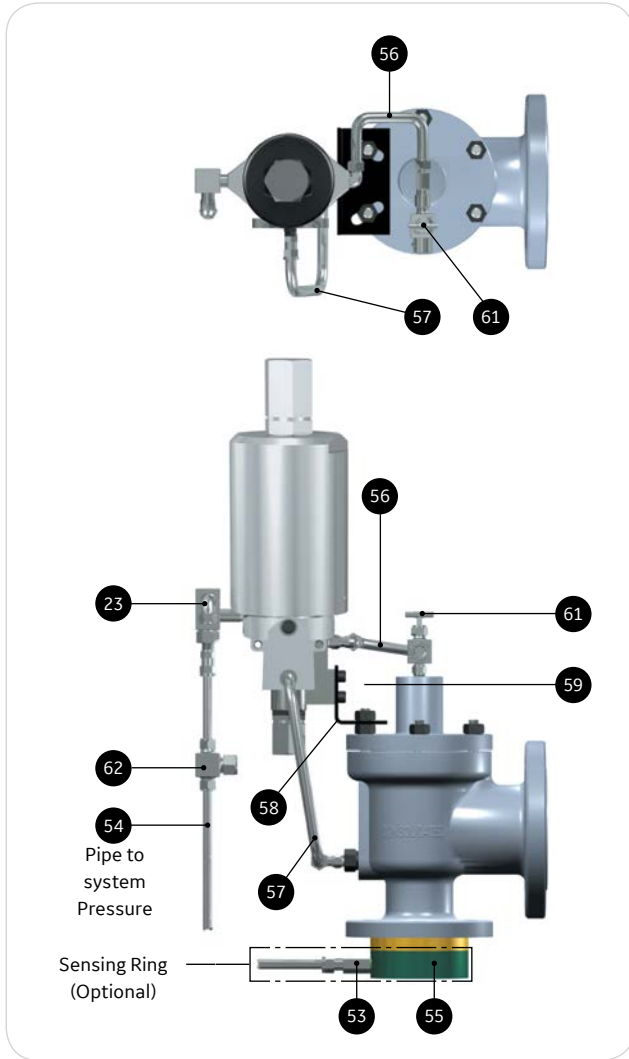

Pilot Valve with Backflow Preventer, Manual Blowdown and Pilot Supply Filter
(Optional for Steam Applications)

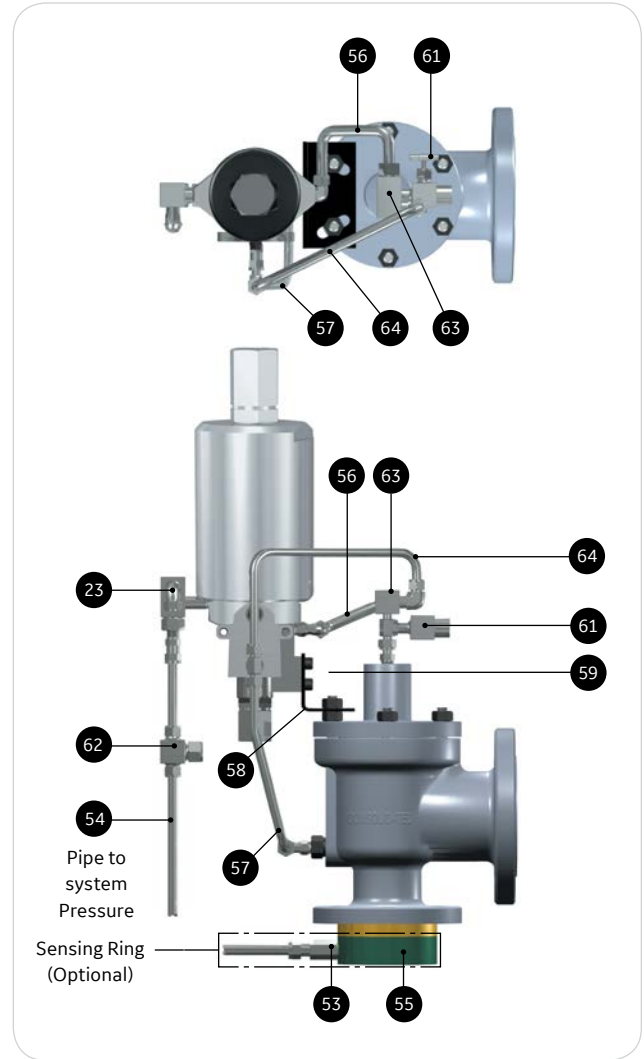

**Pilot Valve with Manual Blowdown & Pilot Supply Filter
(Standard for Steam Applications)
(Optional for Liquid & Gas Applications)**

Part	Material
23 Field Test Connection	316 Stainless Steel
53 Sensing Tube	316 Stainless Steel
54 Sensing Line	316 Stainless Steel
55 Sensing Ring	316 Stainless Steel
56 Dome Line	316 Stainless Steel
57 Discharge Line	316 Stainless Steel
58 Bracket	Carbon Steel
59 Bracket Cap Screw	316 Stainless Steel
61 Needle Valve (Manual Blowdown)	316 Stainless Steel
62 Pilot Supply Filter	316 Stainless Steel

**Pilot Valve with Backflow Preventer,
Manual Blowdown and Pilot Supply Filter
(Optional for Steam Applications)**

Part	Material
23 Field Test Connection	316 Stainless Steel
53 Sensing Tube	316 Stainless Steel
54 Sensing Line	316 Stainless Steel
55 Sensing Ring	316 Stainless Steel
56 Dome Line	316 Stainless Steel
57 Discharge Line	316 Stainless Steel
58 Bracket	Carbon Steel
59 Bracket Cap Screw	316 Stainless Steel
61 Needle Valve (Manual Blowdown)	316 Stainless Steel
62 Pilot Supply Filter	316 Stainless Steel
63 Backflow Preventer	316 Stainless Steel
64 Backflow Preventer Line	316 Stainless Steel

Piping Configurations

2900 Series Type 39MV Modulating Pilot

(Vented to Body Bowl)

Pilot Valve with Standard Field Test Connection
(Standard for all Media Applications)

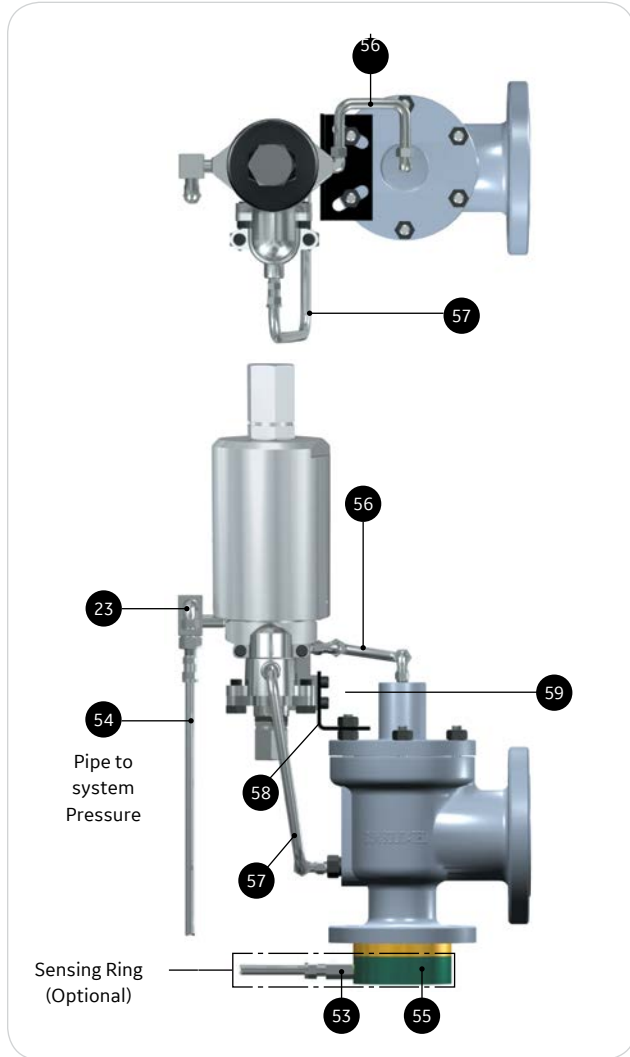

Pilot Valve with Manual Blowdown
(Optional for all Media Applications)

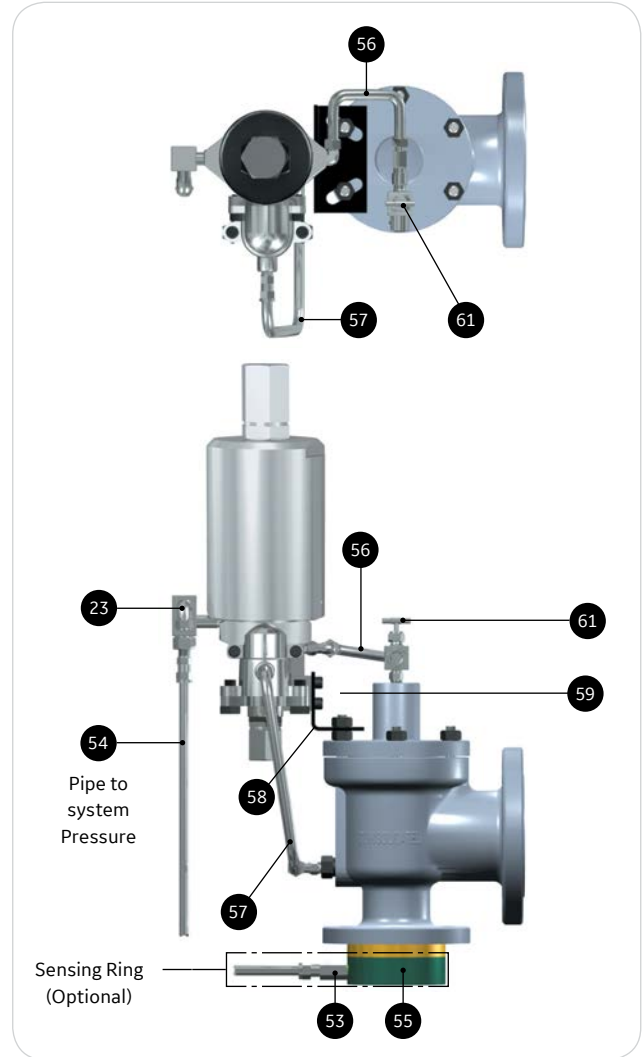

Pilot Valve with Standard Field Test Connection
(Standard for all Media Applications)

	Part	Material
23	Field Test Connection	316 Stainless Steel
53	Sensing Tube	316 Stainless Steel
54	Sensing Line	316 Stainless Steel
55	Sensing Ring	316 Stainless Steel
56	Dome Line	316 Stainless Steel
57	Discharge Line	316 Stainless Steel
58	Bracket	Carbon Steel
59	Bracket Cap Screw	316 Stainless Steel

Pilot Valve with Manual Blowdown
(Optional for all Media Applications)

	Part	Material
23	Field Test Connection	316 Stainless Steel
53	Sensing Tube	316 Stainless Steel
54	Sensing Line	316 Stainless Steel
55	Sensing Ring	316 Stainless Steel
56	Dome Line	316 Stainless Steel
57	Discharge Line	316 Stainless Steel
58	Bracket	Carbon Steel
59	Bracket Cap Screw	316 Stainless Steel
61	Needle Valve (Manual Blowdown)	316 Stainless Steel

Piping Configurations

2900 Series Type 39MV Modulating Pilot

(Vented to Body Bowl)

Pilot Valve with Pilot Supply Filter
(Optional for all Media Applications)

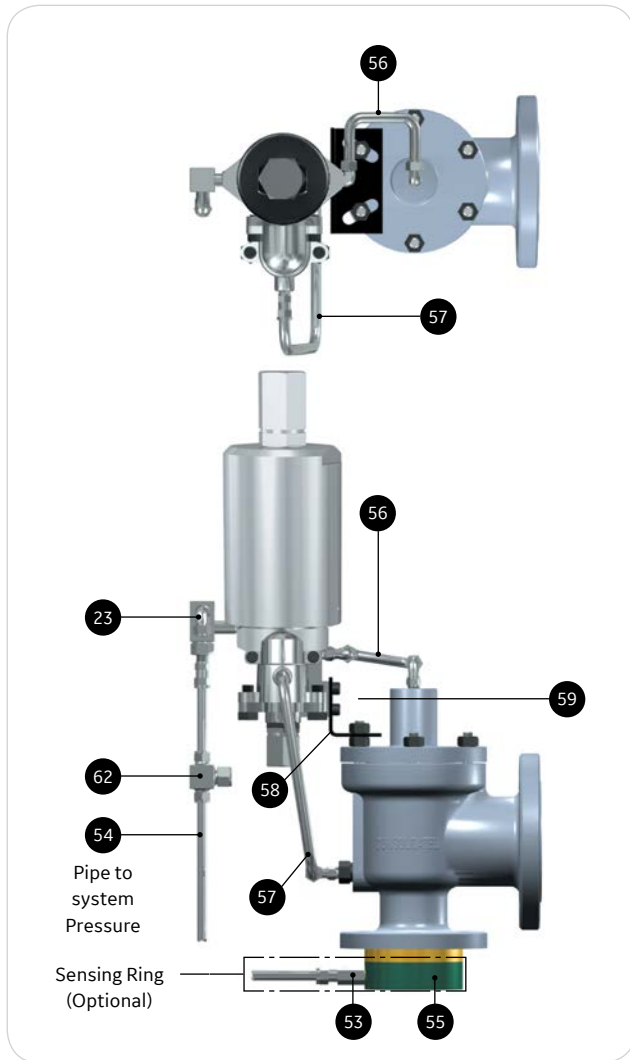

Pilot Valve with Backflow Preventer
(Optional for Liquid & Gas Applications)

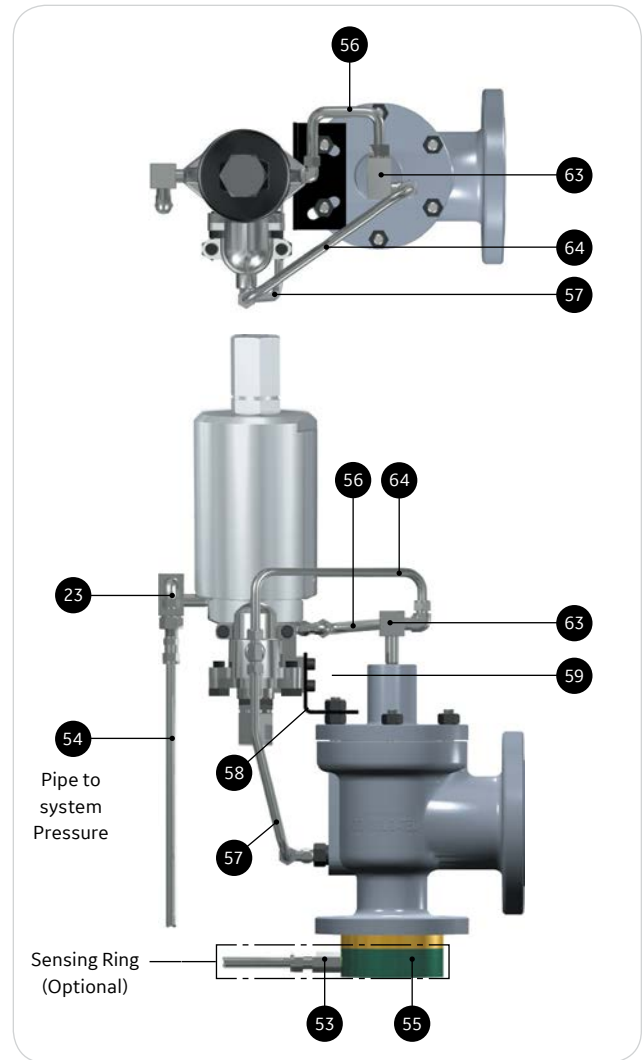

Pilot Valve with Pilot Supply Filter
(Optional for all Media Applications)

	Part	Material
23	Field Test Connection	316 Stainless Steel
53	Sensing Tube	316 Stainless Steel
54	Sensing Line	316 Stainless Steel
55	Sensing Ring	316 Stainless Steel
56	Dome Line	316 Stainless Steel
57	Discharge Line	316 Stainless Steel
58	Bracket	Carbon Steel
59	Bracket Cap Screw	316 Stainless Steel
62	Pilot Supply Filter	316 Stainless Steel

Pilot Valve with Backflow Preventer
(Optional for Liquid & Gas Applications)

	Part	Material
23	Field Test Connection	316 Stainless Steel
53	Sensing Tube	316 Stainless Steel
54	Sensing Line	316 Stainless Steel
55	Sensing Ring	316 Stainless Steel
56	Dome Line	316 Stainless Steel
57	Discharge Line	316 Stainless Steel
58	Bracket	Carbon Steel
59	Bracket Cap Screw	316 Stainless Steel
63	Backflow Preventer	316 Stainless Steel
64	Backflow Preventer Line	316 Stainless Steel

Piping Configurations

2900 Series Type 39MV Modulating Pilot

(Vented to Body Bowl)

Pilot Valve with Manual Blowdown and Pilot Supply Filter
(Standard for Steam Applications)

(Optional for Liquid & Gas Applications)

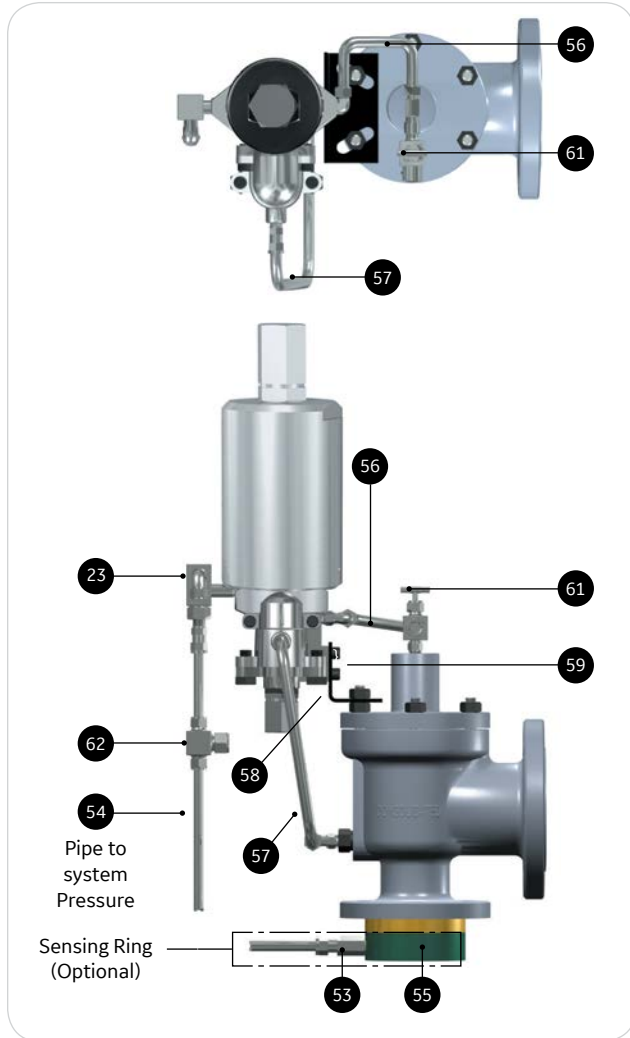

Pilot Valve with Backflow Preventer, Manual Blowdown and Pilot Supply Filter
(Optional for Steam Applications)

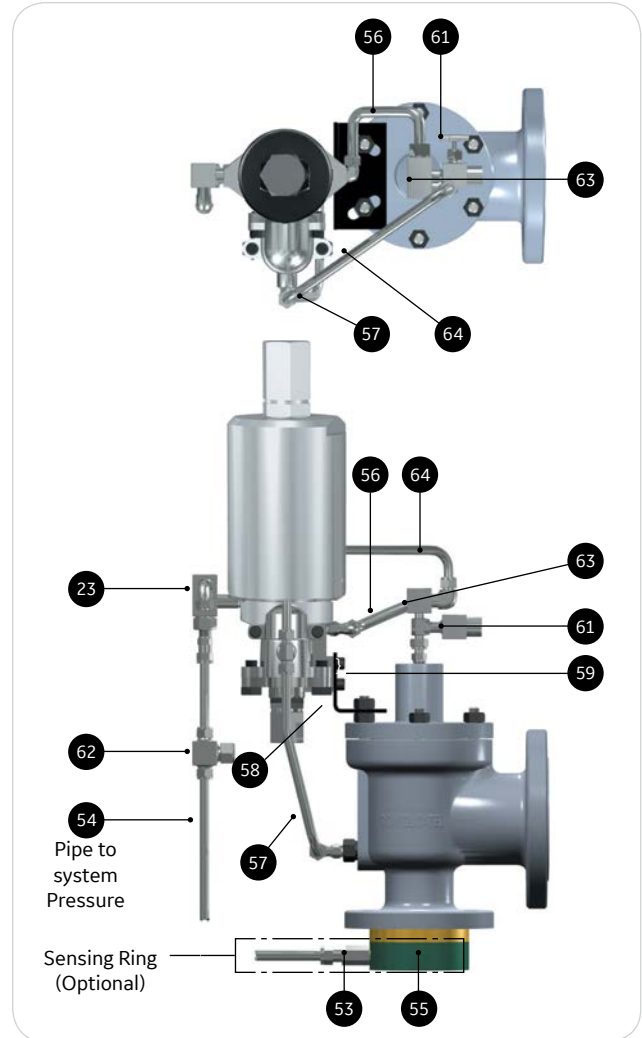

Pilot Valve with Manual Blowdown & Pilot Supply Filter
(Standard for Steam Applications)
(Optional for Liquid & Gas Applications)

Part	Material
23 Field Test Connection	316 Stainless Steel
53 Sensing Tube	316 Stainless Steel
54 Sensing Line	316 Stainless Steel
55 Sensing Ring	316 Stainless Steel
56 Dome Line	316 Stainless Steel
57 Discharge Line	316 Stainless Steel
58 Bracket	Carbon Steel
59 Bracket Cap Screw	316 Stainless Steel
61 Needle Valve (Manual Blowdown)	316 Stainless Steel
62 Pilot Supply Filter	316 Stainless Steel

Pilot Valve with Backflow Preventer,
Manual Blowdown and Pilot Supply Filter
(Optional for Steam Applications)

Part	Material
23 Field Test Connection	316 Stainless Steel
53 Sensing Tube	316 Stainless Steel
54 Sensing Line	316 Stainless Steel
55 Sensing Ring	316 Stainless Steel
56 Dome Line	316 Stainless Steel
57 Discharge Line	316 Stainless Steel
58 Bracket	Carbon Steel
59 Bracket Cap Screw	316 Stainless Steel
61 Needle Valve (Manual Blowdown)	316 Stainless Steel
62 Pilot Supply Filter	316 Stainless Steel
63 Backflow Preventer	316 Stainless Steel
64 Backflow Preventer Line	316 Stainless Steel

Piping Configurations

Alternate Piping Arrangement

2900 Series Type 39MV Modulating Pilot with Heat Exchanger Hot Service
(Also available with Pop Pilot)

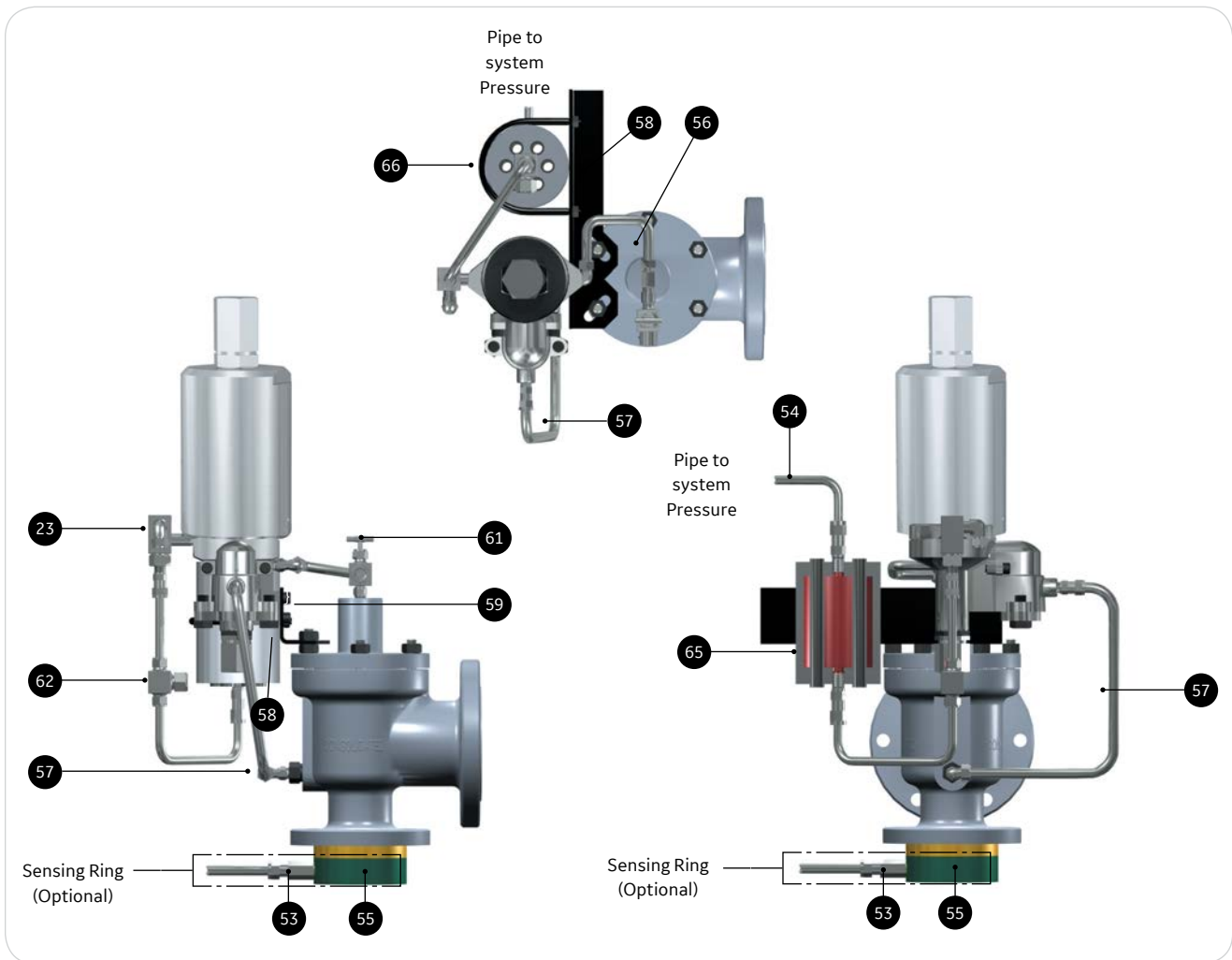

Pilot Valve with Manual Blowdown, Pilot Supply Filter and Heat Exchanger High Temp. [Media above 505°F (263°C)]		
	Part	Material
23	Field Test Connection	316 Stainless Steel
53	Sensing Tube	316 Stainless Steel
54	Sensing Line	316 Stainless Steel
55	Sensing Ring	316 Stainless Steel
56	Dome Line	316 Stainless Steel
57	Discharge Line	316 Stainless Steel
58	Bracket	Carbon Steel
59	Bracket Cap Screw	316 Stainless Steel
61	Needle Valve (Manual Blowdown)	316 Stainless Steel
62	Pilot Supply Filter	316 Stainless Steel
65	Heat Exchanger	316 Stainless Steel
66	Heat Exchanger U-Bolt	316 Stainless Steel

Piping Configurations

2900 Series Type 39MV Modulating Pilot with Heat Exchanger

2900 Series Type 39MV Modulating Pilot with Heat Exchanger Cold Service
(Also available with Pop Pilot)

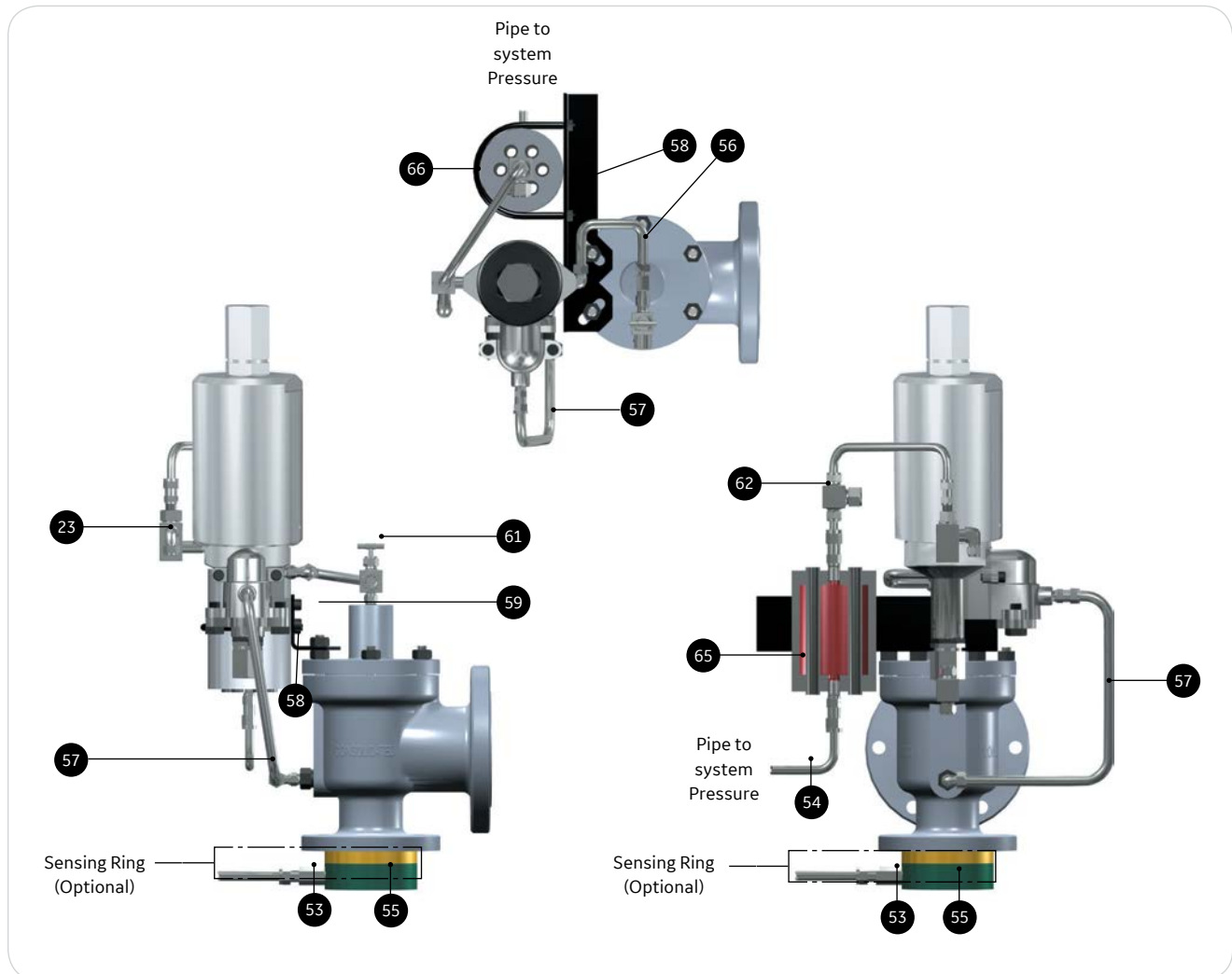

Pilot Valve with Manual Blowdown, Pilot Supply Filter and Heat Exchanger Low Temp. [Media below -40°F (-40°C)]		
	Part	Material
23	Field Test Connection	316 Stainless Steel
53	Sensing Tube	316 Stainless Steel
54	Sensing Line	316 Stainless Steel
55	Sensing Ring	316 Stainless Steel
56	Dome Line	316 Stainless Steel
57	Discharge Line	316 Stainless Steel
58	Bracket	Carbon Steel
59	Bracket Cap Screw	316 Stainless Steel
61	Needle Valve (Manual Blowdown)	316 Stainless Steel
62	Pilot Supply Filter	316 Stainless Steel
65	Heat Exchanger	316 Stainless Steel
66	Heat Exchanger U-Bolt	316 Stainless Steel

Valve Installation

Valve Installation

Valve Connections

The Consolidated 2900 Series flanged valves are equipped with ANSI B16 .5 flanges. For other standards, contact BHGE for your needs.

The facing on raised flanges is a spiral finish, 125 to 250 micro inch roughness (Ra).

All flanged drilling straddles the centerlines of the valve..

Handling and Storage

Safety relief valves should be handled carefully. The internal parts of a pilot-operated safety relief valve are precision-machined and fitted together to maintain perfect alignment. Rough handling may damage the external tubing, pilot, and main valve seats or may cause misalignment sufficient to incur leakage or erratic operation. Safety relief valves are shipped with a protective covering over the inlet and the outlet. This is to prevent damage to the flanged surfaces and entry of foreign material into the valve. If the valves are to be stored before installation, the protective covering should be left intact until installation. A clean, dry storage area is recommended. Valves should always be protected with a suitable covering to prevent entry of foreign material..

Inlet Piping

Pilot-operated safety relief valves must be installed in a vertical upright position. The inlet piping to the valve should be short and direct from the vessel or equipment being protected. The connection to the vessel should be provided with a radius

to permit smooth flow to the valve. Sharp corners should be avoided. If this is not practical, then the inlet should be swaged out at least one additional pipe diameter .

In any event, the pressure drop from the vessel to the valve should not exceed 3 percent of set pressure when the valve is flowing full capacity. In no event should the inlet piping be smaller in diameter than the inlet connection of the valve.

Outlet Piping

Alignment of the internal parts of a pilot-operated safety relief valve is important to ensure proper operation. Although the valve body will withstand a considerable mechanical load, unsupported discharge piping should not impose loads any higher than those stated in the Technical Information Section of this catalog, i.e., anything more than a companion flange, long radius elbow and a short vertical pipe. Care should be taken to ensure thermal expansion of piping and supports does not produce strains in a valve. Spring supports are recommended where necessary to avoid this condition. The discharge piping should be designed to allow for vessel expansion as well as expansion of the discharge pipe itself. This is particularly important on long discharge lines.

Consideration should be given to discharge pipe movement resulting from wind loads. Any oscillation of the discharge piping introduces stress distortion in the valve body, and the resultant movement of the internal parts may cause leakage.

Notes:

1. In no event should the outlet piping be smaller in diameter than the outlet connection of the valve.

Dimensions & Weights

2900 Series Type 39PV Pop Pilot (Pilot Vented to Atmosphere)

2900 Series Type 39PV Pop Pilot
(Pilot Vented to Atmosphere)

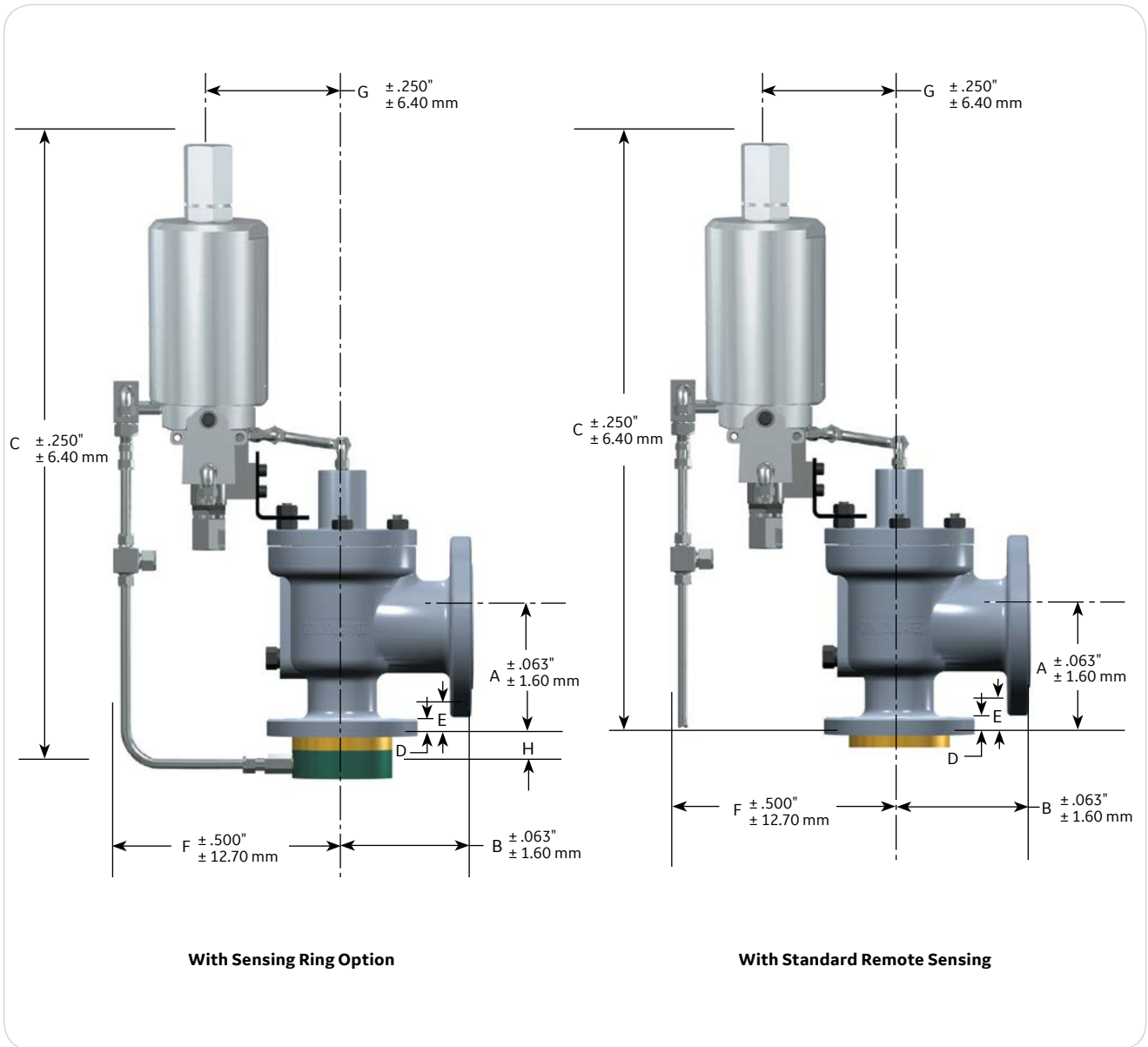

Dimensions & Weights

2900 Series Type 39MV Pop Pilot

(Pilot Vented to Atmosphere)

2900 Series Type 39MV Pop Pilot

(Pilot Vented to Atmosphere)

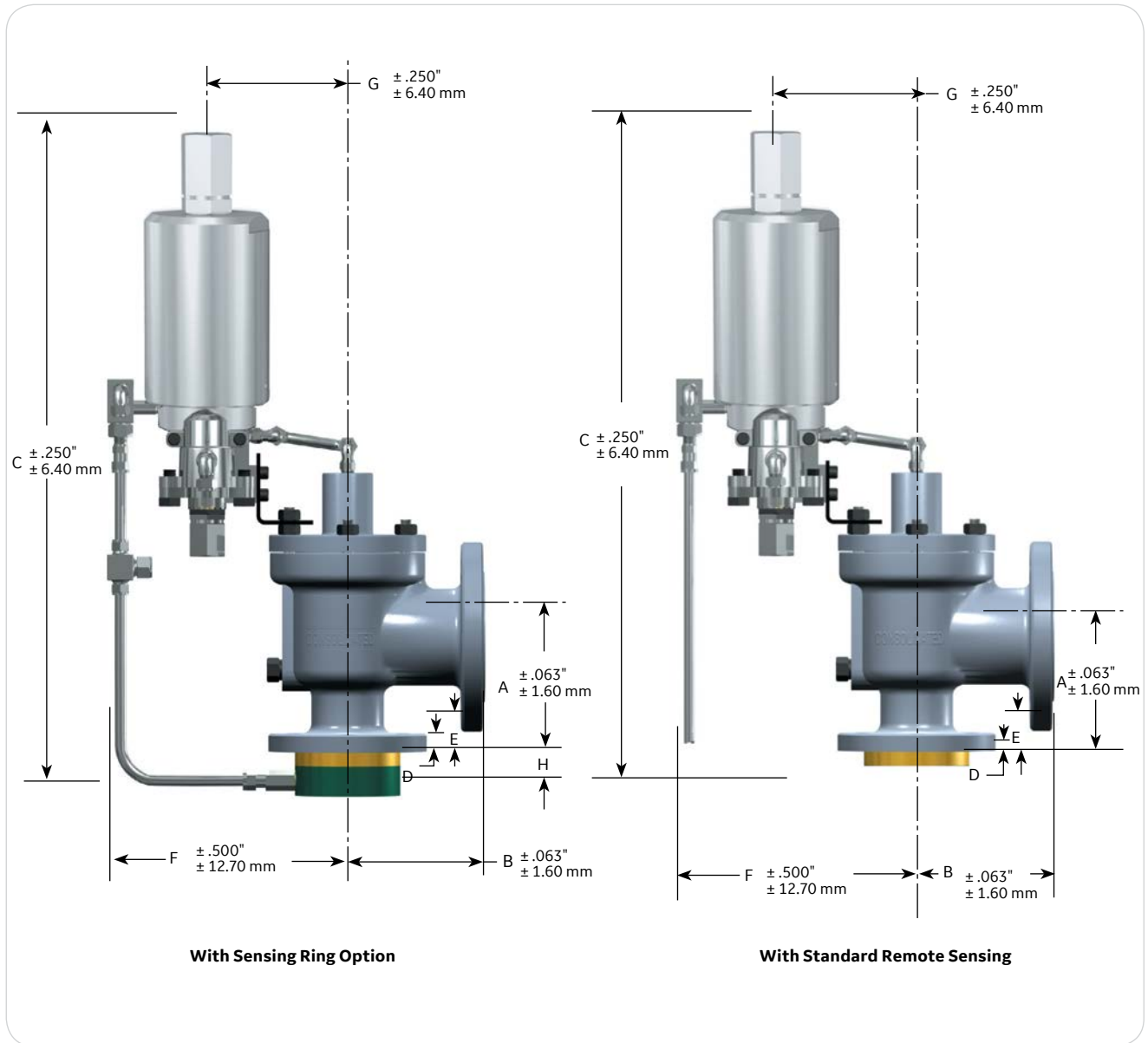

Dimensions & Weights

2900 Series Valve with Type 39PV & 39MV Pilot

Dimensions and Weights - D Orifice																				
Valve Type	A		B		C				D		E		F		G		H1		Approximate Weight	
					STD		Bellows												lb	kg
	in	mm	in	mm	in	mm	in	mm	in	mm	in	mm	in	mm	in	mm	in	mm		
2905	4.13	104.8	4.50	114.3	22.63	574.7	23.63	600.1	.69	17.5	1.13	28.6	8.25	209.6	4.88	123.8	1.50	38.1	40	18.1
2906	4.13	104.8	4.50	114.3	22.63	574.7	23.63	600.1	.69	17.5	1.38	34.9	8.25	209.6	4.88	123.8	1.50	38.1	40	18.1
2910	4.13	104.8	4.50	114.3	22.63	574.7	23.63	600.1	.69	17.5	1.38	34.9	8.25	209.6	4.88	123.8	1.50	38.1	50	22.7
2912	4.13	104.8	4.50	114.3	22.63	574.7	23.63	600.1	.69	17.5	1.38	34.9	9.16	232.6	5.75	146.1	1.50	38.1	50	22.7
2914	4.13	104.8	5.50	139.7	23.25	590.6	24.25	616.0	.69	17.5	1.94	49.2	10.00	254.0	6.63	168.3	1.50	38.1	70	31.8
2916	4.13	104.8	5.50	139.7	23.25	590.6	24.25	616.0	.69	17.5	1.94	49.2	10.00	254.0	6.63	168.3	1.50	38.1	70	31.8
2918	5.50	139.7	7.00	177.8	24.63	625.5	25.63	650.9	.69	17.5	2.44	61.9	10.47	265.9	7.09	180.2	1.50	38.1	150	68.0
2920	4.13	104.8	4.50	114.3	22.63	574.7	23.63	600.1	.69	17.5	1.38	34.9	8.25	209.6	4.88	123.8	1.50	38.1	50	22.7
2922	4.13	104.8	4.50	114.3	22.63	574.7	23.63	600.1	.69	17.5	1.38	34.9	8.25	209.6	4.88	123.8	1.50	38.1	50	22.7
2924	4.13	104.8	5.50	139.7	23.25	590.6	24.25	616.0	.69	17.5	1.94	49.2	10.00	254.0	6.63	168.3	1.50	38.1	70	31.8
2926	4.13	104.8	5.50	139.7	23.25	590.6	24.25	616.0	.69	17.5	1.94	49.2	10.00	254.0	6.63	168.3	1.50	38.1	70	31.8
2928	5.50	139.7	7.00	177.8	24.63	625.5	25.63	650.9	.69	17.5	2.44	61.9	10.47	265.9	7.09	180.2	1.50	38.1	150	68.0

Dimensions and Weights - E Orifice																				
Valve Type	A		B		C				D		E		F		G		H1		Approximate Weight	
					STD		Bellows												lb	kg
	in	mm	in	mm	in	mm	in	mm	in	mm	in	mm	in	mm	in	mm	in	mm		
2905	4.13	104.8	4.50	114.3	22.63	574.7	23.63	600.1	.69	17.5	1.13	28.6	8.25	209.6	4.88	123.8	1.50	38.1	40	18.1
2906	4.13	104.8	4.50	114.3	22.63	574.7	23.63	600.1	.69	17.5	1.38	34.9	8.25	209.6	4.88	123.8	1.50	38.1	40	18.1
2910	4.13	104.8	4.50	114.3	22.63	574.7	23.63	600.1	.69	17.5	1.38	34.9	8.25	209.6	4.88	123.8	1.50	38.1	50	22.7
2912	4.13	104.8	4.50	114.3	22.63	574.7	23.63	600.1	.69	17.5	1.38	34.9	9.16	232.6	5.75	146.1	1.50	38.1	50	22.7
2914	4.13	104.8	5.50	139.7	23.25	590.6	23.25	590.6	.69	17.5	1.94	49.2	10.00	254.0	6.63	168.3	1.50	38.1	70	31.8
2916	4.13	104.8	5.50	139.7	23.25	590.6	24.25	616.0	.69	17.5	1.94	49.2	10.00	254.0	6.63	168.3	1.50	38.1	70	31.8
2918	5.50	139.7	7.00	177.8	24.63	625.5	25.63	650.9	.69	17.5	2.44	61.9	10.47	265.9	7.09	180.2	1.50	38.1	150	68.0
2920	4.13	104.8	4.50	114.3	22.63	574.7	23.63	600.1	.69	17.5	1.38	34.9	8.25	209.6	4.88	123.8	1.50	38.1	50	22.7
2922	4.13	104.8	4.50	114.3	22.63	574.7	23.63	600.1	.69	17.5	1.38	34.9	8.25	209.6	4.88	123.8	1.50	38.1	50	22.7
2924	4.13	104.8	5.50	139.7	23.25	590.6	24.25	616.0	.69	17.5	1.94	49.2	10.00	254.0	6.63	168.3	1.50	38.1	70	31.8
2926	4.13	104.8	5.50	139.7	23.25	590.6	24.25	616.0	.69	17.5	1.94	49.2	10.00	254.0	6.63	168.3	1.50	38.1	70	31.8
2928	5.50	139.7	7.00	177.8	24.63	625.5	25.63	650.9	.69	17.5	2.44	61.9	10.47	265.9	7.09	180.2	1.50	38.1	150	68.0

Notes:

- Does not include thickness of two gaskets required.

Dimensions & Weights

2900 Series Valve with Type 39PV & 39MV Pilot

Dimensions and Weights - F Orifice																				
Valve Type	A		B		C				D		E		F		G		H1		Approximate Weight	
					STD		Bellows													
	in	mm	in	mm	in	mm	in	mm	in	mm	in	mm	in	mm	in	mm	in	mm	lb	kg
2905	4.88	123.8	4.75	120.7	23.25	590.6	24.25	616.0	.69	17.5	1.25	31.8	8.25	209.6	4.88	123.8	1.50	38.1	45	20.4
2906	4.88	123.8	4.75	120.7	23.25	590.6	24.25	616.0	.69	17.5	1.50	38.1	8.25	209.6	4.88	123.8	1.50	38.1	45	20.4
2910	4.88	123.8	6.00	152.4	23.25	590.6	24.25	616.0	.69	17.5	1.56	39.7	8.25	209.6	4.88	123.8	1.50	38.1	50	22.7
2912	4.88	123.8	6.00	152.4	23.25	590.6	24.25	616.0	.69	17.5	1.56	39.7	9.16	232.6	5.75	146.1	1.50	38.1	60	27.2
2914	4.88	123.8	6.50	165.1	23.94	608.0	24.94	633.4	.69	17.5	1.94	49.2	10.00	254.0	6.63	168.3	1.50	38.1	100	45.4
2916	4.88	123.8	6.50	165.1	23.94	608.0	24.94	633.4	.69	17.5	1.94	49.2	10.00	254.0	6.63	168.3	1.50	38.1	100	45.4
2918	5.50	139.7	7.00	177.8	24.75	628.7	25.75	654.1	.69	17.5	2.44	61.9	10.47	265.9	7.09	180.2	1.50	38.1	150	68.0
2920	4.88	123.8	6.00	152.4	23.25	590.6	24.25	616.0	.69	17.5	1.56	39.7	8.25	209.6	4.88	123.8	1.50	38.1	50	22.7
2922	4.88	123.8	6.00	152.4	23.25	590.6	24.25	616.0	.69	17.5	1.56	39.7	8.25	209.6	4.88	123.8	1.50	38.1	50	22.7
2924	4.88	123.8	6.50	165.1	23.94	608.0	24.94	633.4	.69	17.5	1.94	49.2	10.00	254.0	6.63	168.3	1.50	38.1	100	45.4
2926	4.88	123.8	6.50	165.1	23.94	608.0	24.94	633.4	.69	17.5	1.94	49.2	10.00	254.0	6.63	168.3	1.50	38.1	100	45.4
2928	5.50	139.7	7.00	177.8	24.75	628.7	25.75	654.1	.69	17.5	2.44	61.9	10.47	265.9	7.09	180.2	1.50	38.1	150	68.0

Dimensions and Weights - G Orifice																				
Valve Type	A		B		C				D		E		F		G		H1		Approximate Weight	
					STD		Bellows													
	in	mm	in	mm	in	mm	in	mm	in	mm	in	mm	in	mm	in	mm	in	mm	lb	kg
2905	4.88	123.8	4.75	120.7	23.25	590.6	24.25	616.0	.69	17.5	1.25	31.8	8.25	209.6	4.88	123.8	1.50	38.1	55	24.9
2906	4.88	123.8	4.75	120.7	23.25	590.6	24.25	616.0	.69	17.5	1.50	38.1	8.25	209.6	4.88	123.8	1.50	38.1	55	24.9
2910	4.88	123.8	6.00	152.4	23.25	590.6	24.25	616.0	.69	17.5	1.56	39.7	8.25	209.6	4.88	123.8	1.50	38.1	60	27.2
2912	4.88	123.8	6.00	152.4	23.25	590.6	24.25	616.0	.69	17.5	1.56	39.7	9.16	232.6	5.75	146.1	1.50	38.1	65	29.5
2914	4.88	123.8	6.50	165.1	23.94	608.1	25.19	639.8	.69	17.5	1.94	49.2	10.00	254.0	6.63	168.3	1.50	38.1	95	43.1
2916	6.13	155.6	6.75	171.5	25.19	639.8	26.44	671.6	.69	17.5	2.19	55.6	10.00	254.0	6.63	168.3	1.50	38.1	100	45.4
2918	6.13	155.6	6.75	171.5	25.19	639.8	26.44	671.6	.69	17.5	2.69	68.3	10.00	254.0	6.63	168.3	1.50	38.1	110	49.9
2920	4.88	123.8	6.00	152.4	23.25	590.6	24.25	616.0	.69	17.5	1.56	39.7	8.25	209.6	4.88	123.8	1.50	38.1	60	27.2
2922	4.88	123.8	6.00	152.4	23.25	590.6	24.25	616.0	.69	17.5	1.56	39.7	9.16	232.6	5.75	146.1	1.50	38.1	65	29.5
2924	4.88	123.8	6.50	165.1	23.94	608.1	25.19	639.8	.69	17.5	1.94	49.2	10.00	254.0	6.63	168.3	1.50	38.1	95	43.1
2926	6.13	155.6	6.75	171.5	25.19	639.8	26.44	671.6	.69	17.5	2.19	55.6	10.00	254.0	6.63	168.3	1.50	38.1	100	45.4
2928	6.13	155.6	6.75	171.5	25.19	639.8	26.44	671.6	.69	17.5	2.69	68.3	10.00	254.0	6.63	168.3	1.50	38.1	110	49.9

Notes:

- Does not include thickness of two gaskets required.

Dimensions & Weights

2900 Series Valve with Type 39PV & 39MV Pilot

Dimensions and Weights - H Orifice																				
Valve Type	A		B		C				D		E		F		G		H1		Approximate Weight	
					STD		Bellows													
	in	mm	in	mm	in	mm	in	mm	in	mm	in	mm	in	mm	in	mm	in	mm	lb	kg
2905	5.13	130.2	4.88	123.8	24.56	623.9	24.56	623.9	.69	17.5	1.25	31.8	8.25	209.6	4.88	123.8	1.50	38.1	60	27.2
2906	5.13	130.2	4.88	123.8	24.56	623.9	24.56	623.9	.69	17.5	1.56	39.7	8.25	209.6	4.88	123.8	1.50	38.1	60	27.2
2910	5.13	130.2	4.88	123.8	24.56	623.9	24.56	623.9	.69	17.5	1.69	42.9	9.19	233.4	5.81	147.7	1.50	38.1	65	29.5
2912	6.06	154.0	6.38	161.9	25.63	650.9	25.63	650.9	.69	17.5	1.69	42.9	9.25	235.0	5.88	149.2	1.50	38.1	85	38.6
2914	6.06	154.0	6.38	161.9	26.13	663.6	26.13	663.6	.69	17.5	2.19	55.6	10.31	262.0	6.94	176.2	1.50	38.1	130	59.0
2916	6.06	154.0	6.38	161.9	26.13	663.6	26.13	663.6	.69	17.5	2.19	55.6	10.31	262.0	6.94	176.2	1.50	38.1	140	63.5
2920	5.13	130.2	4.88	123.8	24.56	623.9	24.56	623.9	.69	17.5	1.69	42.9	9.19	233.4	5.81	147.7	1.50	38.1	65	29.5
2922	5.13	130.2	4.88	123.8	24.56	623.9	24.56	623.9	.69	17.5	1.69	42.9	9.19	233.4	5.81	147.7	1.50	38.1	65	29.5
2924	6.06	154.0	6.38	161.9	25.69	652.5	25.69	652.5	.69	17.5	2.19	55.6	9.25	235.0	5.88	149.2	1.50	38.1	90	40.8
2926	6.06	154.0	6.38	161.9	26.13	663.6	26.13	663.6	.69	17.5	2.19	55.6	10.31	262.0	6.94	176.2	1.50	38.1	140	63.5

Dimensions and Weights - J Orifice																				
Valve Type	A		B		C				D		E		F		G		H1		Approximate Weight	
					STD		Bellows													
	in	mm	in	mm	in	mm	in	mm	in	mm	in	mm	in	mm	in	mm	in	mm	lb	kg
2905	5.38	136.5	4.88	123.8	25.34	643.7	25.34	643.7	.69	17.5	1.31	33.4	9.25	235.0	5.88	149.2	1.50	38.1	75	34.0
2906	5.38	136.5	4.88	123.8	25.34	643.7	25.34	643.7	.69	17.5	1.56	39.7	9.25	235.0	5.88	149.2	1.50	38.1	75	34.0
2910	7.25	184.2	7.13	181.0	25.09	637.4	25.09	637.4	.69	17.5	1.81	46.1	9.38	238.1	6.00	152.4	1.50	38.1	100	45.4
2912	7.25	184.2	7.13	181.0	27.81	706.5	27.81	706.5	.69	17.5	1.81	46.1	10.50	266.7	7.13	181.0	1.50	38.1	170	77.1
2914	7.25	184.2	7.13	181.0	27.81	706.5	27.81	706.5	.69	17.5	2.19	55.6	10.50	266.7	7.13	181.0	1.50	38.1	195	88.5
2916	7.25	184.2	7.13	181.0	27.81	706.5	27.81	706.5	.69	17.5	2.56	65.1	10.50	266.7	7.13	181.0	1.50	38.1	220	99.8
2920	7.25	184.2	7.13	181.0	25.09	637.4	25.09	637.4	.69	17.5	1.81	46.1	9.38	238.1	6.00	152.4	1.50	38.1	100	45.4
2922	7.25	184.2	7.13	181.0	27.69	703.3	27.69	703.3	.69	17.5	1.81	46.1	10.50	266.7	7.13	181.0	1.50	38.1	100	45.4
2924	7.25	184.2	7.13	181.0	27.81	706.5	27.81	706.5	.69	17.5	2.19	55.6	10.50	266.7	7.13	181.0	1.50	38.1	180	81.6
2926	7.25	184.2	7.13	181.0	27.81	706.5	27.81	706.5	.69	17.5	2.56	65.1	10.50	266.7	7.13	181.0	1.50	38.1	220	99.8

Notes:

1. Does not include thickness of two gaskets required.

Dimensions & Weights

2900 Series Valve with Type 39PV & 39MV Pilot

Dimensions and Weights - K Orifice																				
Valve Type	A		B		C				D		E		F		G		H1		Approximate Weight	
					STD		Bellows												lb	kg
	in	mm	in	mm	in	mm	in	mm	in	mm	in	mm	in	mm	in	mm	in	mm		
2905	6.13	155.6	6.38	161.9	25.88	657.2	25.88	657.2	.69	17.5	1.44	36.5	9.38	238.1	6.00	152.4	1.50	38.1	110	49.9
2906	6.13	155.6	6.38	161.9	25.88	657.2	25.88	657.2	.69	17.5	1.81	46.1	9.38	238.1	6.00	152.4	1.50	38.1	115	52.2
2910	6.13	155.6	6.38	161.9	26.06	662.0	26.06	662.0	.69	17.5	1.94	49.2	10.00	254.0	6.63	168.3	1.50	38.1	140	63.5
2912	7.25	184.2	7.13	181.0	27.19	690.6	27.19	690.6	.69	17.5	1.94	49.2	10.00	254.0	6.63	168.3	1.50	38.1	150	68.0
2914	7.81	198.5	8.50	215.9	28.56	725.5	28.56	725.5	.69	17.5	2.19	55.6	10.88	276.2	7.50	190.5	1.50	38.1	300	136.1
2916	7.75	196.9	8.50	215.9	28.50	723.9	28.25	717.6	.69	17.5	2.56	65.1	10.88	276.2	7.50	190.5	1.50	38.1	320	145.2
2920	6.13	155.6	6.38	161.9	26.19	665.2	26.19	665.2	.69	17.5	1.94	49.2	10.00	254.0	6.63	168.3	1.50	38.1	140	63.5
2922	6.13	155.6	6.38	161.9	26.19	665.2	26.19	665.2	.69	17.5	1.94	49.2	10.00	254.0	6.63	168.3	1.50	38.1	140	63.5
2924	7.25	184.2	7.13	181.0	27.31	693.8	28.56	725.5	.69	17.5	2.19	55.6	10.00	254.0	6.63	168.3	1.50	38.1	165	74.8
2926	7.75	196.9	8.50	215.9	28.50	723.9	26.13	663.6	.69	17.5	2.56	65.1	10.88	276.2	7.50	190.5	1.50	38.1	320	145.2

Dimensions and Weights - L Orifice																				
Valve Type	A		B		C				D		E		F		G		H1		Approximate Weight	
					STD		Bellows												lb	kg
	in	mm	in	mm	in	mm	in	mm	in	mm	in	mm	in	mm	in	mm	in	mm		
2905	6.13	155.6	6.50	165.1	26.88	682.6	26.88	682.6	.69	17.5	1.44	36.5	10.25	260.4	6.88	174.6	1.50	38.1	140	63.5
2906	6.13	155.6	6.50	165.1	26.88	682.6	26.88	682.6	.69	17.5	1.81	46.1	10.25	260.4	6.88	174.6	1.50	38.1	145	65.8
2910	7.06	179.4	7.13	181.0	28.19	716.0	28.19	716.0	.69	17.5	1.94	49.2	10.63	269.9	7.25	184.2	1.50	38.1	220	99.8
2912	7.06	179.4	8.00	203.2	28.19	716.0	28.19	716.0	.69	17.5	2.19	55.6	10.63	269.9	7.25	184.2	1.50	38.1	230	104.3
2914	7.75	196.9	8.75	222.3	29.50	749.3	29.25	743.0	.69	17.5	2.44	61.9	12.19	309.6	8.81	223.9	1.50	38.1	360	163.3
2916	7.75	196.9	8.75	222.3	29.50	749.3	29.25	743.0	.69	17.5	2.81	71.5	12.19	309.6	8.81	223.9	1.50	38.1	370	167.8
2920	7.06	179.4	7.13	181.0	28.19	716.0	28.19	716.0	.69	17.5	1.94	49.2	10.63	269.9	7.25	184.2	1.50	38.1	220	99.8
2922	7.06	179.4	8.00	203.2	28.19	716.0	28.19	716.0	.69	17.5	2.19	55.6	10.63	269.9	7.25	184.2	1.50	38.1	230	104.3
2924	7.75	196.9	8.75	222.3	29.50	749.3	29.25	743.0	.69	17.5	2.44	61.9	12.19	309.6	8.81	223.9	1.50	38.1	360	163.3
2926	7.75	196.9	8.75	222.3	29.50	749.3	29.25	743.0	.69	17.5	2.81	71.5	12.19	309.6	8.81	223.9	1.50	38.1	370	167.8

Notes:

- Does not include thickness of two gaskets required.

Dimensions & Weights

2900 Series Valve with Type 39PV & 39MV Pilot

Dimensions and Weights - M Orifice																				
Valve Type	A		B		C				D		E		F		G		H1		Approximate Weight	
					STD		Bellows												lb	kg
	in	mm	in	mm	in	mm	in	mm	in	mm	in	mm	in	mm	in	mm	in	mm		
2905	7.00	177.8	7.25	184.2	27.88	708.0	27.88	708.0	.69	17.5	1.63	41.3	10.44	265.1	7.06	179.4	1.50	38.1	185	83.9
2906	7.00	177.8	7.25	184.2	27.88	708.0	27.88	708.0	.69	17.5	1.94	49.2	10.44	265.1	7.06	179.4	1.50	38.1	190	86.2
2910	7.00	177.8	7.25	184.2	28.13	714.4	28.13	714.4	.69	17.5	1.94	49.2	10.44	265.1	7.06	179.4	1.50	38.1	230	104.3
2912	7.00	177.8	8.00	203.2	28.69	728.7	28.69	728.7	.69	17.5	2.19	55.6	11.75	298.5	8.38	212.7	1.50	38.1	300	136.1
2914	7.75	196.9	8.75	222.3	29.44	747.7	29.44	747.7	.69	17.5	2.44	61.9	11.75	298.5	8.38	212.7	1.50	38.1	340	154.2
2920	7.00	177.8	7.25	184.2	28.13	714.4	28.13	714.4	.69	17.5	1.94	49.2	10.44	265.1	7.06	179.4	1.50	38.1	230	104.3
2922	7.00	177.8	8.00	203.2	28.69	728.7	28.69	728.7	.69	17.5	2.19	55.6	10.44	265.1	7.06	179.4	1.50	38.1	300	136.1
2924	7.75	196.9	8.75	222.3	29.44	747.7	29.44	747.7	.69	17.5	2.44	61.9	11.75	298.5	8.38	212.7	1.50	38.1	340	154.2

Dimensions and Weights - N Orifice																				
Valve Type	A		B		C				D		E		F		G		H1		Approximate Weight	
					STD		Bellows												lb	kg
	in	mm	in	mm	in	mm	in	mm	in	mm	in	mm	in	mm	in	mm	in	mm		
2905	7.75	196.9	8.25	209.6	29.06	738.2	29.06	738.2	.69	17.5	1.63	41.3	10.63	269.9	7.25	184.2	1.50	38.1	220	99.8
2906	7.75	196.9	8.25	209.6	29.06	738.2	29.06	738.2	.69	17.5	1.94	49.2	10.63	269.9	7.25	184.2	1.50	38.1	225	102.1
2910	7.75	196.9	8.25	209.6	29.44	747.7	29.44	747.7	.69	17.5	1.94	49.2	10.94	277.8	7.56	192.1	1.50	38.1	260	117.9
2912	7.75	196.9	8.75	222.3	29.94	760.4	29.94	760.4	.69	17.5	2.19	55.6	12.13	308.0	8.75	222.3	1.50	38.1	360	163.3
2914	7.75	196.9	8.75	222.3	29.94	760.4	29.94	760.4	.69	17.5	2.44	61.9	12.13	308.0	8.75	222.3	1.50	38.1	380	172.4
2920	7.75	196.9	8.25	209.6	29.44	747.7	29.44	747.7	.69	17.5	1.94	49.2	10.94	277.8	7.56	192.1	1.50	38.1	260	117.9
2922	7.75	196.9	8.75	222.3	29.94	760.4	29.94	760.4	.69	17.5	2.19	55.6	12.13	308.0	8.75	222.3	1.50	38.1	360	163.3
2924	7.75	196.9	8.75	222.3	29.94	760.4	29.94	760.4	.69	17.5	2.44	61.9	12.13	308.0	8.75	222.3	1.50	38.1	380	172.4

Dimensions and Weights - P Orifice																				
Valve Type	A		B		C				D		E		F		G		H1		Approximate Weight	
					STD		Bellows												lb	kg
	in	mm	in	mm	in	mm	in	mm	in	mm	in	mm	in	mm	in	mm	in	mm		
2905	7.13	181.0	9.00	228.6	30.25	768.4	30.25	768.4	.69	17.5	1.63	41.3	10.88	276.2	7.50	190.5	1.50	38.1	260	117.9
2906	7.13	181.0	9.00	228.6	30.25	768.4	30.25	768.4	.69	17.5	1.94	49.2	10.88	276.2	7.50	190.5	1.50	38.1	270	122.5
2910	8.88	225.4	10.00	254.0	32.44	823.9	32.44	823.9	.69	17.5	1.94	49.2	11.19	284.2	7.81	198.5	1.50	38.1	350	158.8
2912	8.88	225.4	10.00	254.0	32.94	836.6	32.94	836.6	.69	17.5	2.19	55.6	12.75	323.9	9.38	238.1	1.50	38.1	530	240.4
2914	8.88	225.4	10.00	254.0	32.94	836.6	32.94	836.6	.69	17.5	2.44	61.9	12.75	323.9	9.38	238.1	1.50	38.1	545	247.2
2920	8.88	225.4	10.00	254.0	32.44	823.9	32.44	823.9	.69	17.5	1.94	49.2	11.19	284.2	7.81	198.5	1.50	38.1	350	158.8
2923	8.88	225.4	10.00	254.0	32.94	836.6	32.94	836.6	.69	17.5	2.19	55.6	12.75	323.9	9.38	238.1	1.50	38.1	530	240.4
2924	8.88	225.4	10.00	254.0	32.94	836.6	32.94	836.6	.69	17.5	2.44	61.9	12.75	323.9	9.38	238.1	1.50	38.1	545	247.2

Notes:

1. Does not include thickness of two gaskets required.

Dimensions & Weights

2900 Series Valve with Type 39PV & 39MV Pilot

Dimensions and Weights - Q Orifice																				
Valve Type	A		B		C				D		E		F		G		H1		Approximate Weight	
					STD		Bellows												lb	kg
	in	mm	in	mm	in	mm	in	mm	in	mm	in	mm	in	mm	in	mm	in	mm		
2905	9.44	239.7	9.50	241.3	32.50	825.5	32.50	825.5	.81	20.7	1.81	46.1	12.63	320.7	9.25	235.0	1.50	38.1	430	195.0
2906	9.44	239.7	9.50	241.3	32.50	825.5	32.50	825.5	.81	20.7	2.25	57.2	12.63	320.7	9.25	235.0	1.50	38.1	445	201.8
2910	9.44	239.7	9.50	241.3	33.13	841.4	33.13	841.4	.81	20.7	2.25	57.2	12.88	327.0	9.50	241.3	1.50	38.1	530	240.4
2912	9.44	239.7	9.50	241.3	33.75	857.3	33.75	857.3	.81	20.7	2.69	68.3	12.94	328.6	9.56	242.9	1.50	38.1	645	292.6
2920	9.44	239.7	9.50	241.3	32.25	819.2	32.25	819.2	.81	20.7	2.25	57.2	12.63	320.7	9.25	235.0	1.50	38.1	445	201.8
2922	9.44	239.7	9.50	241.3	33.75	857.3	33.75	857.3	.81	20.7	2.69	68.3	12.94	328.6	9.56	242.9	1.50	38.1	645	292.6

Dimensions and Weights - R Orifice																				
Valve Type	A		B		C				D		E		F		G		H1		Approximate Weight	
					STD		Bellows												lb	kg
	in	mm	in	mm	in	mm	in	mm	in	mm	in	mm	in	mm	in	mm	in	mm		
2905	9.44	239.7	9.50	241.3	34.63	879.5	34.63	879.5	.81	20.7	1.81	46.1	12.94	328.6	9.56	242.9	1.50	38.1	495	224.5
2906	9.44	239.7	9.50	241.3	34.63	879.5	34.63	879.5	.81	20.7	2.25	57.2	12.94	328.6	9.56	242.9	1.50	38.1	510	231.3
2910	9.44	239.7	10.50	266.7	34.63	879.5	34.63	879.5	.81	20.7	2.25	57.2	12.94	328.6	9.56	242.9	1.50	38.1	550	249.5
2912	9.44	239.7	10.50	266.7	34.88	885.8	34.88	885.8	.81	20.7	2.69	68.3	13.25	336.6	9.88	250.8	1.50	38.1	675	306.2
2920	9.44	239.7	9.50	241.3	34.63	879.5	34.63	879.5	.81	20.7	2.25	57.2	12.94	328.6	9.56	242.9	1.50	38.1	510	231.3
2922	9.44	239.7	10.50	266.7	34.88	885.8	34.88	885.8	.81	20.7	2.69	68.3	13.25	336.6	9.88	250.8	1.50	38.1	675	306.2

Dimensions and Weights - T Orifice																				
Valve Type	A		B		C				D		E		F		G		H1		Approximate Weight	
					STD		Bellows												lb	kg
	in	mm	in	mm	in	mm	in	mm	in	mm	in	mm	in	mm	in	mm	in	mm		
2905	10.88	276.2	11.00	279.4	35.00	889.0	35.00	889.0	.81	20.7	1.94	49.2	13.75	349.3	10.38	263.5	1.50	38.1	620	281.2
2906	10.88	276.2	11.00	279.4	35.00	889.0	35.00	889.0	.81	20.7	2.44	61.9	13.75	349.3	10.38	263.5	1.50	38.1	640	290.3
2910	10.88	276.2	11.00	279.4	35.25	895.4	35.25	895.4	.81	20.7	2.44	61.9	13.75	349.3	10.38	263.5	1.50	38.1	840	381.0
2912	10.88	276.2	11.00	279.4	35.25	895.4	35.25	895.4	.81	20.7	3.00	76.2	13.75	349.3	10.38	263.5	1.50	38.1	925	419.6
2920	10.88	276.2	11.00	279.4	35.25	895.4	35.25	895.4	.81	20.7	2.44	61.9	13.75	349.3	10.38	263.5	1.50	38.1	840	381.0
2922	10.88	276.2	11.00	279.4	35.25	895.4	35.25	895.4	.81	20.7	3.00	76.2	13.75	349.3	10.38	263.5	1.50	38.1	925	419.6

Notes:

- Does not include thickness of two gaskets required.

Dimensions & Weights

2900 Series Valve with Type 39PV & 39MV Pilot

Dimensions and Weights - U Orifice																				
Valve Type	A		B		C				D		E		F		G		H1		Approximate Weight	
					STD		Bellows													
	in	mm	in	mm	in	mm	in	mm	in	mm	in	mm	in	mm	in	mm	in	mm	lb	kg
2905	10.88	276.2	11.00	279.4	35.00	889.0	35.00	889.0	.81	20.7	1.94	49.2	13.75	349.3	10.38	263.5	1.50	38.1	620	281.2
2906	10.88	276.2	11.00	279.4	35.00	889.0	35.00	889.0	.81	20.7	2.44	61.9	13.75	349.3	10.38	263.5	1.50	38.1	640	290.3
2910	10.88	276.2	11.00	279.4	35.25	895.4	35.25	895.4	.81	20.7	2.44	61.9	13.75	349.3	10.38	263.5	1.50	38.1	840	381.0
2912	10.88	276.2	11.00	279.4	35.25	895.4	35.25	895.4	.81	20.6	3.00	76.2	13.75	349.3	10.38	263.5	1.50	38.1	925	419.6
2920	10.88	276.2	11.00	279.4	35.25	895.4	35.25	895.4	.81	20.7	2.44	61.9	13.75	349.3	10.38	263.5	1.50	38.1	840	381.0
2922	10.88	276.2	11.00	279.4	35.25	895.4	35.25	895.4	.81	20.6	3.00	76.2	13.75	349.3	10.38	263.5	1.50	38.1	925	419.6

Dimensions and Weights - V Orifice																				
Valve Type	A		B		C				D		E		F		G		H1		Approximate Weight	
					STD		Bellows													
	in	mm	in	mm	in	mm	in	mm	in	mm	in	mm	in	mm	in	mm	in	mm	lb	kg
2905	12.00	304.8	16.00	406.4	43.50	1104.9	43.50	1104.9	.81	20.7	2.00	50.8	16.94	430.2	13.25	336.6	1.50	38.1	1600	725.7
2906	12.00	304.8	16.00	406.4	43.50	1104.9	43.50	1104.9	.81	20.7	2.69	68.3	16.94	430.2	13.25	336.6	1.50	38.1	1700	771.1
2910	12.00	304.8	16.00	406.4	46.38	1177.9	46.38	1177.9	.81	20.7	2.69	68.3	17.94	455.6	14.25	362.0	1.50	38.1	2000	907.2
2920	12.00	304.8	16.00	406.4	46.38	1177.9	46.38	1177.9	.81	20.7	2.69	68.3	17.94	455.6	14.25	362.0	1.50	38.1	2000	907.2

Dimensions and Weights - W Orifice																				
Valve Type	A		B		C				D		E		F		G		H1		Approximate Weight	
					STD		Bellows													
	in	mm	in	mm	in	mm	in	mm	in	mm	in	mm	in	mm	in	mm	in	mm	lb	kg
2905	14.00	355.6	16.00	406.4	49.25	1251.0	49.25	1251.0	.81	20.7	2.81	71.5	17.94	455.6	14.25	362.0	1.50	38.1	2800	1270.1
2906	14.00	355.6	16.00	406.4	49.25	1251.0	49.25	1251.0	.81	20.7	2.94	74.6	17.94	455.6	14.25	362.0	1.50	38.1	2860	1297.3
2910	14.00	355.6	16.00	406.4	49.25	1251.0	49.25	1251.0	.81	20.7	2.94	74.6	17.94	455.6	14.25	362.0	1.50	38.1	2860	1297.3
2920	14.00	355.6	16.00	406.4	49.25	1251.0	49.25	1251.0	.81	20.7	2.94	74.6	17.94	455.6	14.25	362.0	1.50	38.1	2860	1297.3

Notes:

- Does not include thickness of two gaskets required.

Pressure/Temperature

Pressure Temperature Tables

How to Use Rating Tables

The pressure/temperature limitations of the 2900 series valves are based on the ASME B16 .5, 1996 Edition, the design limit of the pilot (6250 psig [430 .92 barg]), and the base coverplate bolting material. The tables on the following pages give the ratings for standard valves. For valves made from special materials, the maximum pressure may exceed the pressure stated in the tables, but may be limited to the pressure ratings given in ANSI B16 .5.

The included tables specify important data about the valve sizes, flange ratings, pressure and temperature limits, back pressure ratings, and materials with allowable temperature ranges.

After determining valve size from the Valve Sizing section or capacity tables in this section, select the proper set of tables and graphs (in the following pages) for the size valve. Enter the pressure/temperature graphs and determine valve type. Review the table of data for that size valve to get other pertinent information.

Procedure

Enter the graph on page 2900.97 for the "J" size, select set pressure on the bottom scale at 500 psig (34 .47 barg), then follow this line vertically upward until it intersects the 100°F (38°C) line. The selection is a 2910J valve.

Results

Referring to the table on page 2900.96, the valve is 3" (76 .20 mm) -300 x 4" (101 .60 mm)-150 without a heat exchanger. The back pressure limit is satisfactory for 50 psig (3 .45 barg) back pressure.

Heat Exchange

For temperatures below -40°F (-40°C) and above 505°F (262 .8°C), a heat exchanger must be used..

Important Information

The lowest temperature for valves with Inconel® 625

LCF Bellows is -400°F (-240 .0°C). In 1995, API made a change in the centerline dimensions for safety relief valves eliminating the 2 .5" (63 .50 mm) connections. Wherever Consolidated safety relief valves specify 2.5" (63 .50 mm) inlets or outlets, these have been changed to 3" (76 .20 mm). The 2 .5" (63 .50 mm) connections specified in API 526 Third Edition, February 1984, are available on special order for replacement of existing valves. In these cases the pressure/temperature limits are the same for either size.

Notes:

1. All information stated here for the 2900 valve is based on ASME Section VIII Code and ANSI B16.5.
2. When soft seats are used, they may govern the valve pressure/temperature rating.
3. Not every application is suitable for using a heat exchanger. The heat exchanger must be sized to meet the service conditions for each application.

Example	
Valve Set Pressure	500 psig (34.47 barg)
Back Pressure	50 psig (3.45 barg)
Temperature	100° F (37.8° C)
Valve	"J"

Pressure/Temperature

Selection Table for Vapors, Gases and Liquids

2900 Series Valve, D Orifice - ASME Area: 0.128 in² (0.825 cm²)

Pressure Temperature Ratings for "D" Orifice										
Valve Type	ASME Ratings, D Orifice - (0.128 in ² (0.825 cm ²) Actual)								Backpressure Limits @ 100°F (37.8°C)	
	Standard Material of Construction								Conventional & Bellows	
	-20 to 100°F (-28.9 to 37.8°C)		450°F (232.2°C)		800°F (426.7°C)		1000°F (537.8°C)			
	psig	barg	psig	barg	psig	barg	psig	barg	psig	barg
2905	290	19.99	185	12.75	80	5.51	-	-	280	19.30
2906	750	51.71	685	47.22	410	28.26	-	-	290	19.99
2910	750	51.71	685	47.22	410	28.26	-	-	290	19.99
2912	1500	103.42	1365	94.11	825	56.88	-	-	290	19.99
2914	2250	155.13	2050	141.34	1235	85.15	-	-	750	51.71
2916	3750	258.55	3420	235.80	2055	141.68	-	-	750	51.71
2918	6250	430.92	5700	393.00	3430	236.49	-	-	750	51.71
2920	-	-	-	-	510	35.16	215	14.82	290	19.99
2922	-	-	-	-	1015	69.98	430	29.64	290	19.99
2924	-	-	-	-	1525	105.14	650	44.81	750	51.71
2926	-	-	-	-	2540	175.12	1080	74.46	750	51.71
2928	-	-	-	-	4230	291.64	1800	124.10	750	51.71

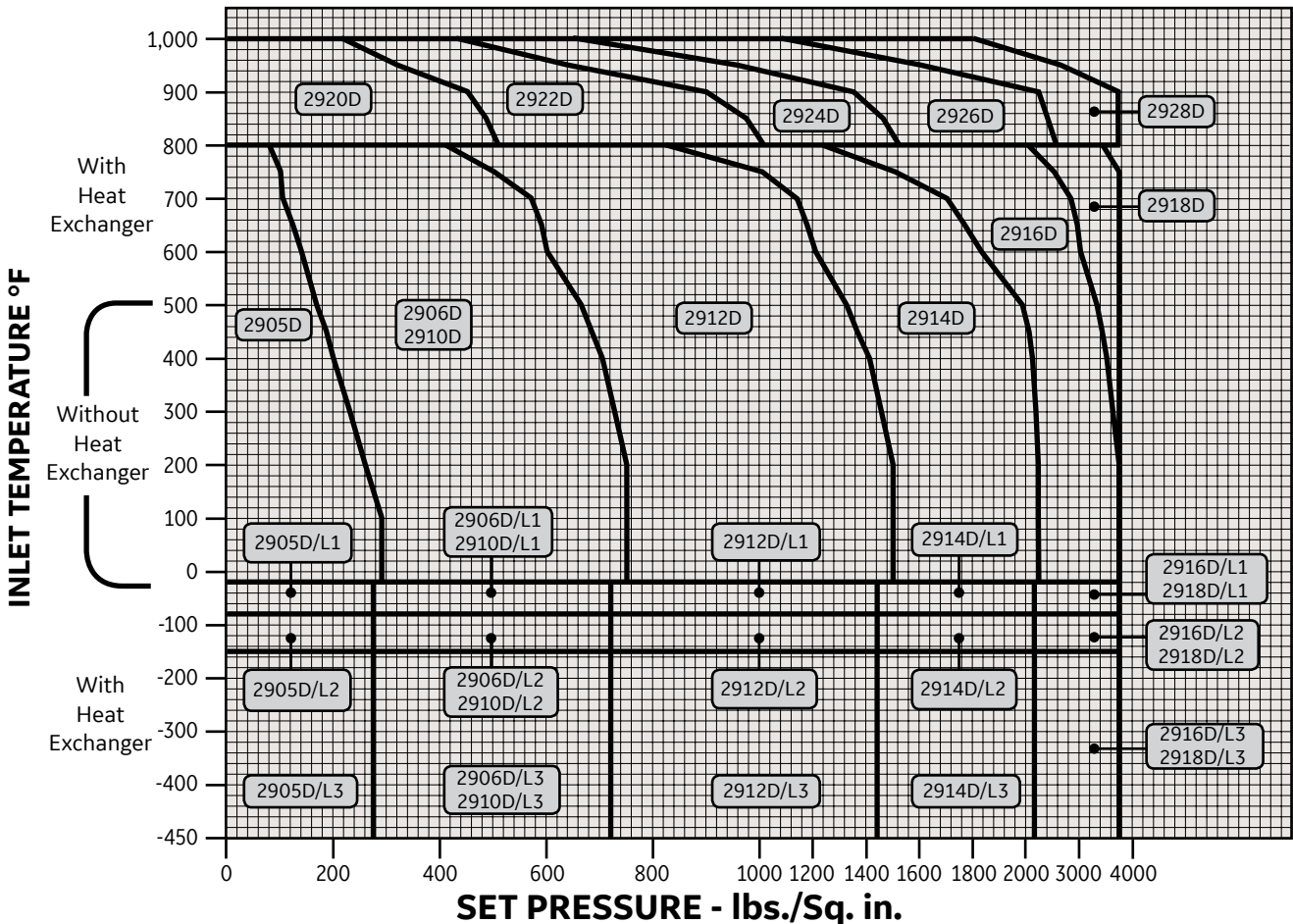

Pressure/Temperature

Selection Table for Vapors, Gases and Liquids

2900 Series Valve, E Orifice - ASME Area: 0.228 in² (1.470 cm²)

Pressure Temperature Ratings for "E" Orifice										
Valve Type	ASME Ratings, E Orifice - (0.228 in ² (1.470 cm ²) Actual)								Backpressure Limits @ 100°F (37.8°C)	
	Standard Material of Construction								Conventional & Bellows	
	-20 to 100°F (-28.9 to 37.8°C)		450°F (232.2°C)		800°F (426.7°C)		1000°F (537.8°C)			
	psig	barg	psig	barg	psig	barg	psig	barg	psig	barg
2905	290	19.99	185	12.75	80	5.51	-	-	280	19.30
2906	750	51.71	685	47.22	410	28.26	-	-	290	19.99
2910	750	51.71	685	47.22	410	28.26	-	-	290	19.99
2912	1500	103.42	1365	94.11	825	56.88	-	-	290	19.99
2914	2250	155.13	2050	141.34	1235	85.15	-	-	750	51.71
2916	3750	258.55	3420	235.80	2055	141.68	-	-	750	51.71
2918	6250	430.92	5700	393.00	3430	236.49	-	-	750	51.71
2920	-	-	-	-	510	35.16	215	14.82	290	19.99
2922	-	-	-	-	1015	69.98	430	29.64	290	19.99
2924	-	-	-	-	1525	105.14	650	44.81	750	51.71
2926	-	-	-	-	2540	175.12	1080	74.46	750	51.71
2928	-	-	-	-	4230	291.64	1800	124.10	750	51.71

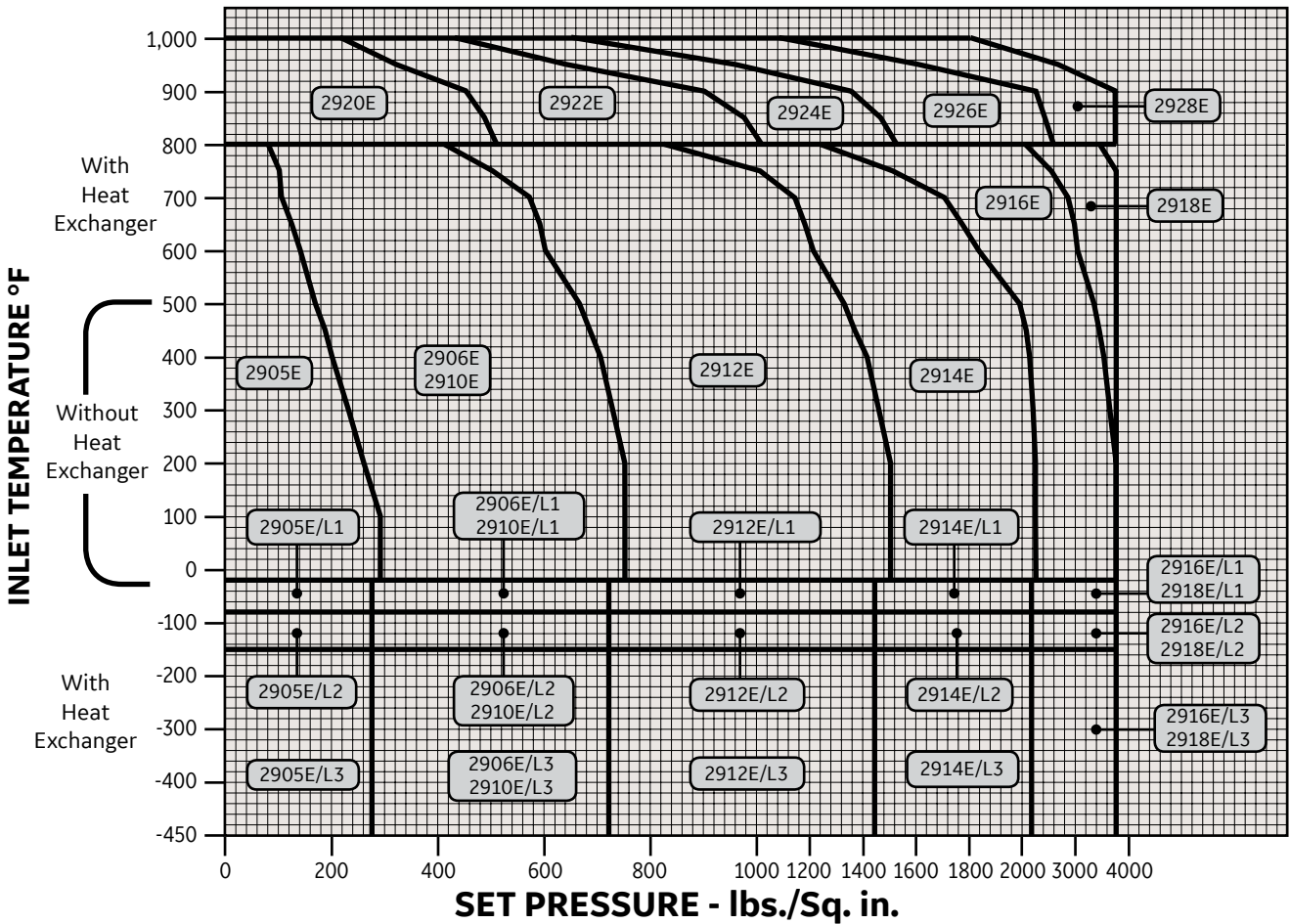

Pressure/Temperature

Selection Table for Vapors, Gases and Liquids

2900 Series Valve, F Orifice - ASME Area: 0.357 in² (2.302 cm²)

Pressure Temperature Ratings for "F" Orifice										
Valve Type	ASME Ratings, F Orifice - (0.357 in ² (2.302 cm ²) Actual)								Backpressure Limits @ 100°F (37.8°C)	
	Standard Material of Construction								Conventional & Bellows	
	-20 to 100°F (-28.9 to 37.8°C)		450°F (232.2°C)		800°F (426.7°C)		1000°F (537.8°C)			
	psig	barg	psig	barg	psig	barg	psig	barg	psig	barg
2905	290	19.99	185	12.75	80	5.51	-	-	280	19.30
2906	750	51.71	685	47.22	410	28.26	-	-	290	19.99
2910	750	51.71	685	47.22	410	28.26	-	-	290	19.99
2912	1500	103.42	1365	94.11	825	56.88	-	-	290	19.99
2914	2250	155.13	2050	141.34	1235	85.15	-	-	750	51.71
2916	3750	258.55	3420	235.80	2055	141.68	-	-	750	51.71
2918	6250	430.92	5700	393.00	3430	236.49	-	-	750	51.71
2920	-	-	-	-	510	35.16	215	14.82	290	19.99
2922	-	-	-	-	1015	69.98	430	29.64	290	19.99
2924	-	-	-	-	1525	105.14	650	44.81	750	51.71
2926	-	-	-	-	2540	175.12	1080	74.46	750	51.71
2928	-	-	-	-	4230	291.64	1800	124.10	750	51.71

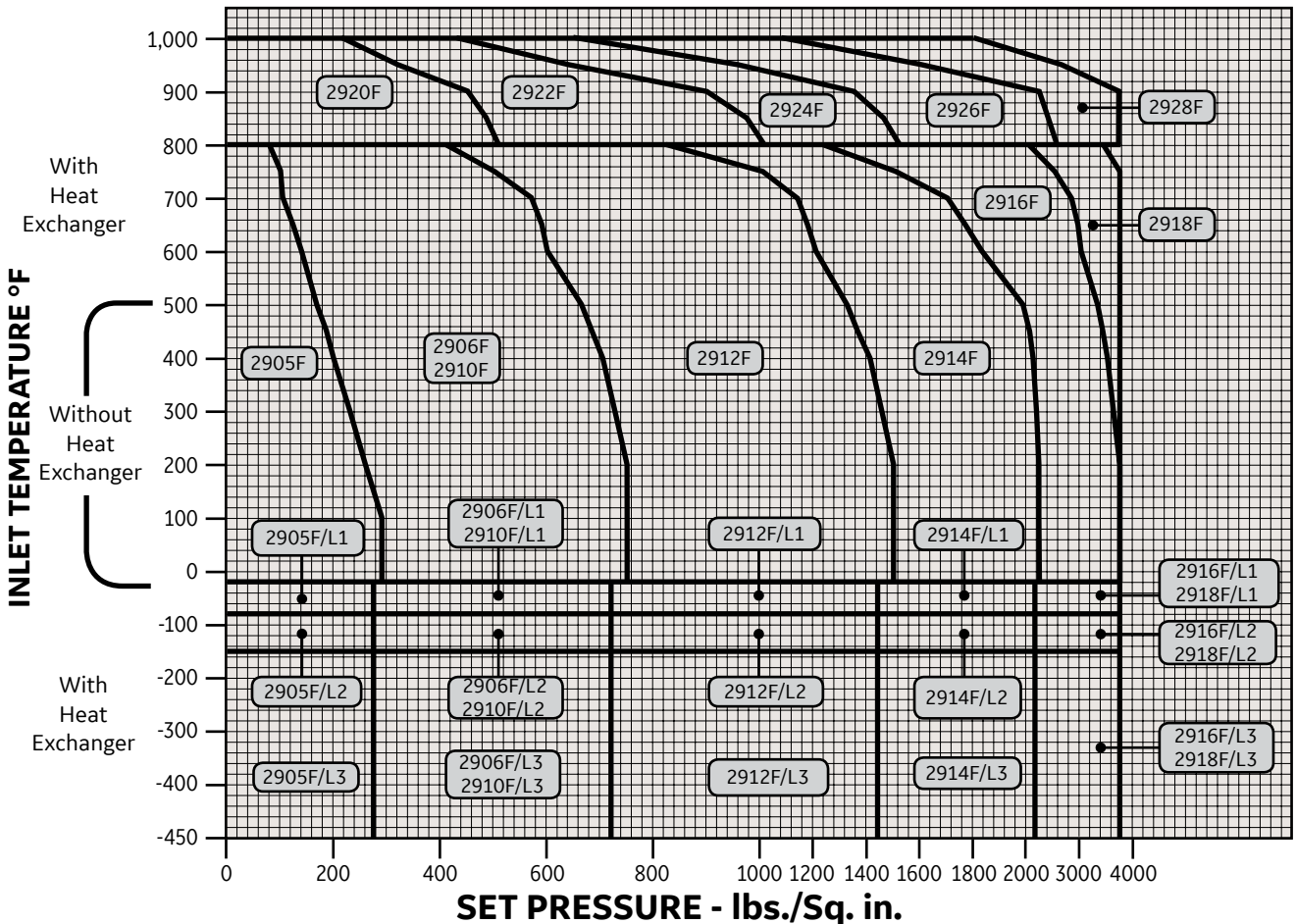

Pressure/Temperature

Selection Table for Vapors, Gases and Liquids

2900 Series Valve, G Orifice - ASME Area: 0.585 in² (3.774 cm²)

Pressure Temperature Ratings for "G" Orifice										
Valve Type	ASME Ratings, G Orifice - (0.585 in ² (3.774 cm ²) Actual)								Backpressure Limits @ 100°F (37.8°C)	
	Standard Material of Construction								Conventional & Bellows	
	-20 to 100 °F (-28.9 to 37.8°C)		450°F (232.2°C)		800°F (426.7°C)		1000°F (537.8°C)			
	psig	barg	psig	barg	psig	barg	psig	barg	psig	barg
2905	290	19.99	185	12.75	80	5.51	-	-	280	19.30
2906	750	51.71	685	47.22	410	28.26	-	-	290	19.99
2910	750	51.71	685	47.22	410	28.26	-	-	290	19.99
2912	1500	103.42	1365	94.11	825	56.88	-	-	290	19.99
2914	2250	155.13	2050	141.34	1235	85.15	-	-	750	51.71
2916	3750	258.55	3420	235.80	2055	141.68	-	-	750	51.71
2918	6250	430.92	5700	393.00	3430	236.49	-	-	750	51.71
2920	-	-	-	-	510	35.16	215	14.82	290	19.99
2922	-	-	-	-	1015	69.98	430	29.64	290	19.99
2924	-	-	-	-	1525	105.14	650	44.81	750	51.71
2926	-	-	-	-	2540	175.12	1080	74.46	750	51.71
2928	-	-	-	-	4230	291.64	1800	124.10	750	51.71

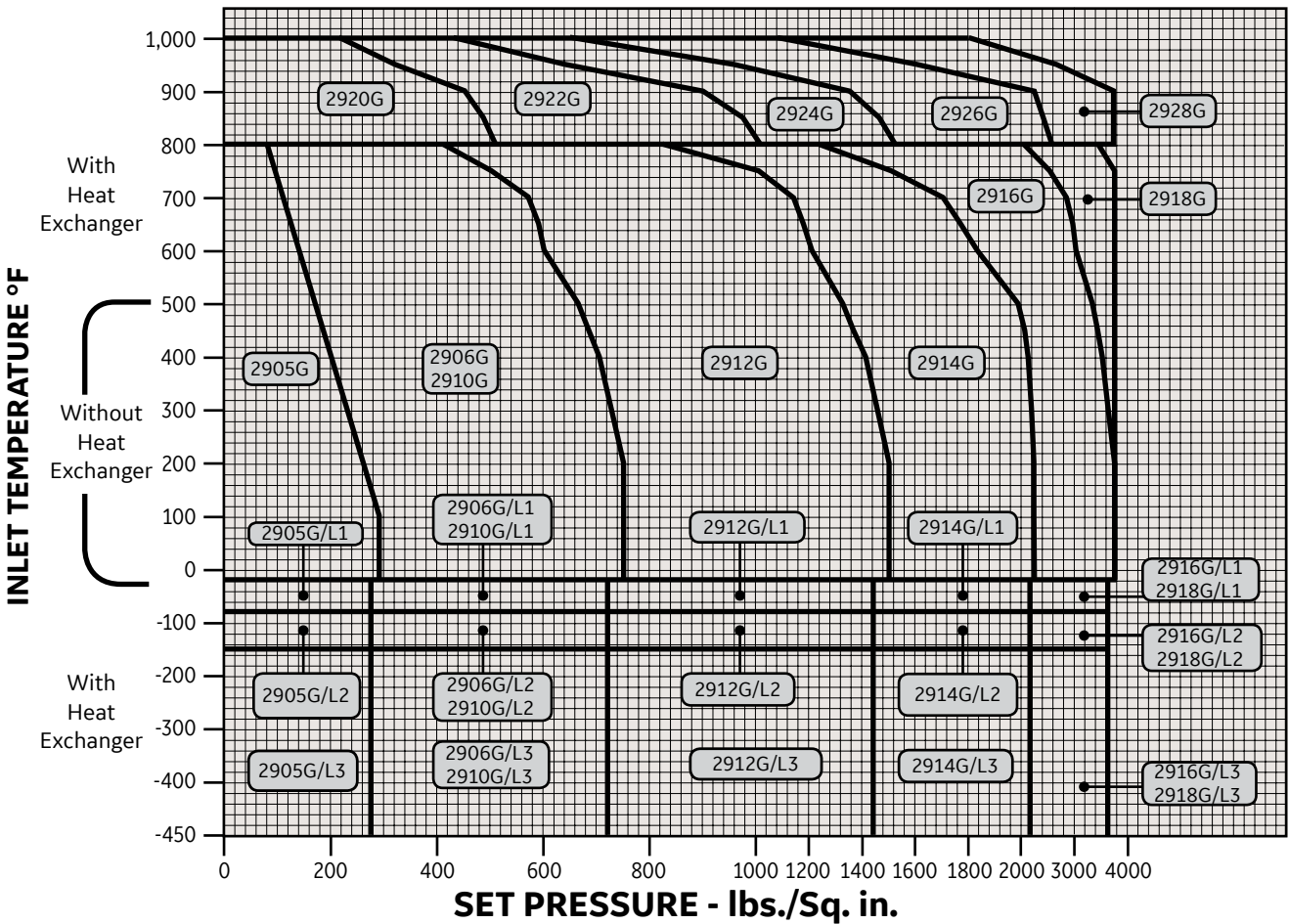

Pressure/Temperature

Selection Table for Vapors, Gases and Liquids

2900 Series Valve, H Orifice - ASME Area: 0.913 in² (5.888 cm²)

Pressure Temperature Ratings for "H" Orifice										
Valve Type	ASME Ratings, H Orifice - (0.913 in ² (5.888 cm ²) Actual)								Backpressure Limits @ 100°F (37.8°C)	
	Standard Material of Construction								Conventional & Bellows	
	-20 to 100°F (-28.9 to 37.8°C)		450°F (232.2°C)		800°F (426.7°C)		1000°F (537.8°C)			
	psig	barg	psig	barg	psig	barg	psig	barg	psig	barg
2905	290	19.99	185	12.75	80	5.51	-	-	280	19.30
2906	750	51.71	685	47.22	410	28.26	-	-	290	19.99
2910	750	51.71	685	47.22	410	28.26	-	-	290	19.99
2912	1500	103.42	1365	94.11	825	56.88	-	-	290	19.99
2914	2250	155.13	2050	141.34	1235	85.15	-	-	290	19.99
2916	3750	258.55	3420	235.80	2055	141.68	-	-	750	51.71
2920	-	-	-	-	510	35.16	215	14.82	290	19.99
2922	-	-	-	-	1015	69.98	430	29.64	290	19.99
2924	-	-	-	-	1525	105.14	650	44.81	290	19.99
2926	-	-	-	-	2540	175.12	1080	74.46	750	51.71

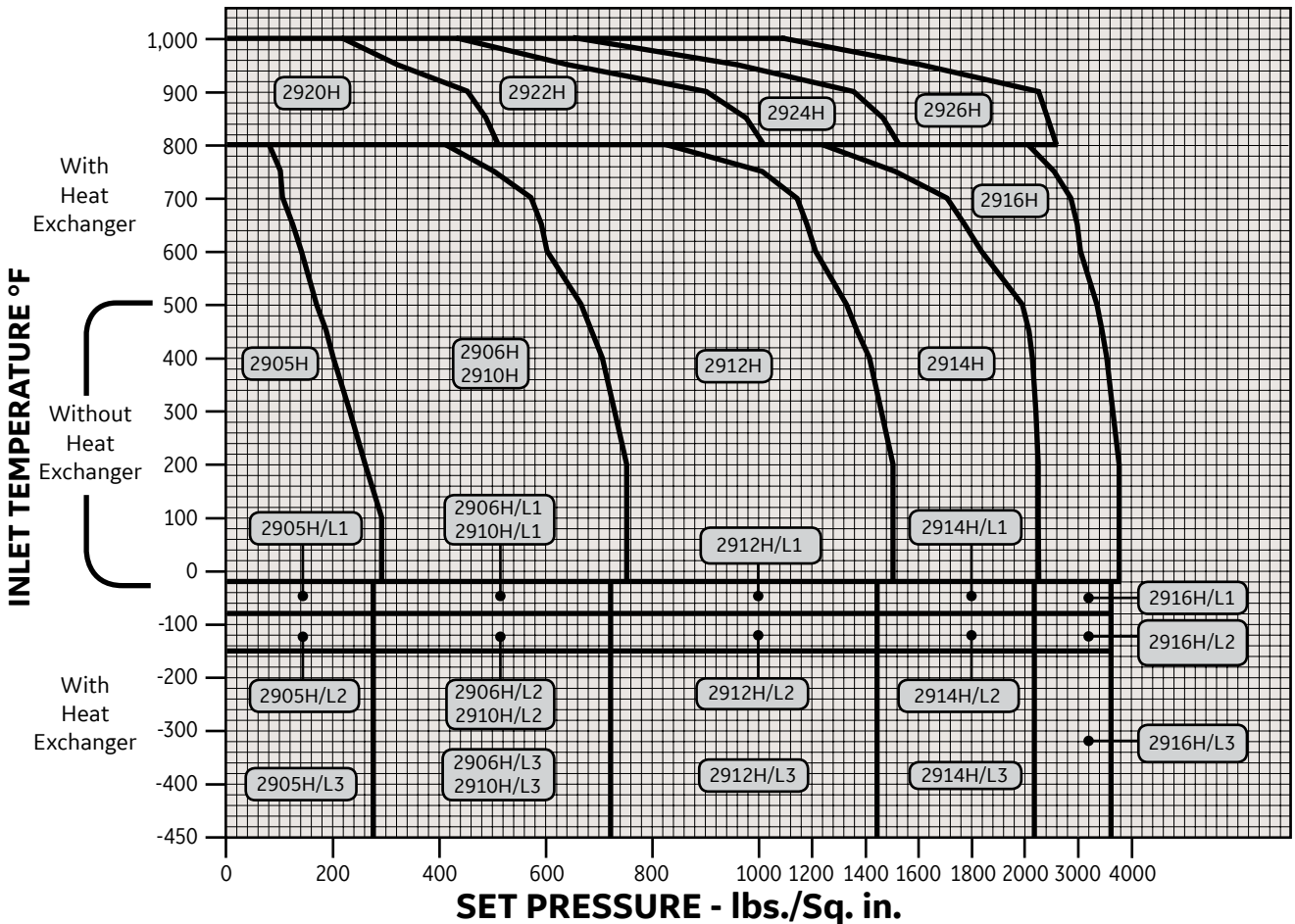

Pressure/Temperature

Selection Table for Vapors, Gases and Liquids

2900 Series Valve, J Orifice - ASME Area: 1.496 in² (9.652 cm²)

Pressure Temperature Ratings for "J" Orifice										
Valve Type	ASME Ratings, J Orifice - (1.496 in ² (9.652 cm ²) Actual)								Backpressure Limits @ 100°F (37.8°C)	
	Standard Material of Construction								Conventional & Bellows	
	-20 to 100°F (-28.9 to 37.8°C)		450°F (232.2°C)		800°F (426.7°C)		1000°F (537.8°C)			
	psig	barg	psig	barg	psig	barg	psig	barg	psig	barg
2905	290	19.99	185	12.75	80	5.51	-	-	280	19.30
2906	750	51.71	685	47.22	410	28.26	-	-	290	19.99
2910	750	51.71	685	47.22	410	28.26	-	-	290	19.99
2912	1500	103.42	1365	94.11	825	56.88	-	-	290	19.99
2914	2250	155.13	2050	141.34	1235	85.15	-	-	290	19.99
2916	3750	258.55	3420	235.80	2055	141.68	-	-	750	51.71
2920	-	-	-	-	510	35.16	215	14.82	290	19.99
2922	-	-	-	-	1015	69.98	430	29.64	290	19.99
2924	-	-	-	-	1525	105.14	650	44.81	290	19.99
2926	-	-	-	-	2540	175.12	1080	74.46	750	51.71

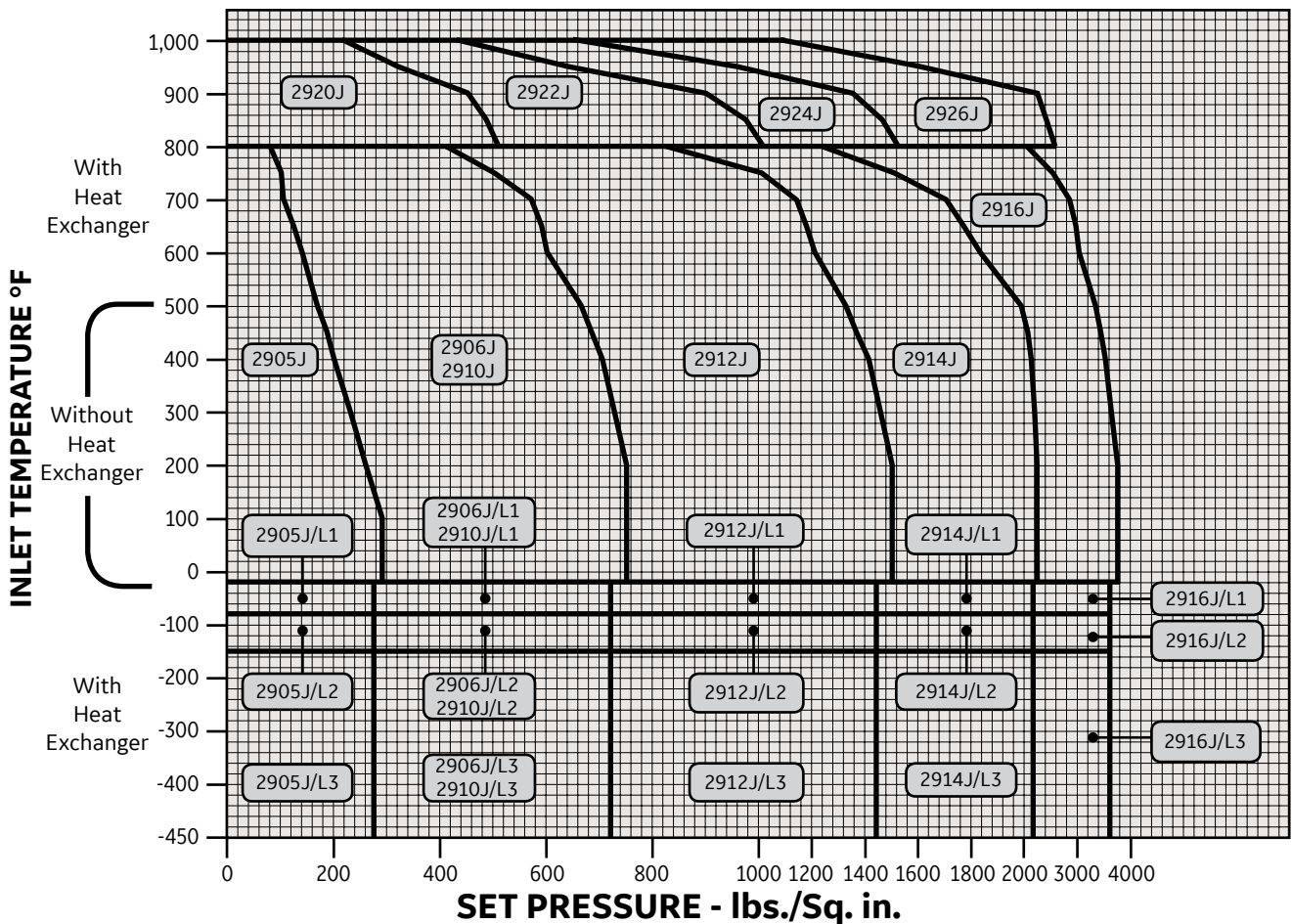

Pressure/Temperature

Selection Table for Vapors, Gases and Liquids

2900 Series Valve, K Orifice - ASME Area: 2.138 in² (13.794 cm²)

Pressure Temperature Ratings for "K" Orifice										
Valve Type	ASME Ratings, K Orifice - (2.138 in ² (13.794 cm ²) Actual)								Backpressure Limits @ 100°F (37.8°C)	
	Standard Material of Construction								Conventional & Bellows	
	-20 to 100°F (-28.9 to 37.8°C)		450°F (232.2°C)		800°F (426.7°C)		1000°F (537.8°C)			
	psig	barg	psig	barg	psig	barg	psig	barg	psig	barg
2905	290	19.99	185	12.76	80	5.52	-	-	280	19.31
2906	750	51.71	685	47.23	410	28.27	-	-	290	19.99
2910	750	51.71	685	47.23	410	28.27	-	-	290	19.99
2912	1500	103.42	1365	94.11	825	56.88	-	-	290	19.99
2914	2250	155.13	2050	141.34	1235	85.15	-	-	290	19.99
2916	3750	258.55	3420	235.80	2055	141.69	-	-	750	51.71
2920	-	-	-	-	510	35.16	215	14.82	290	19.99
2922	-	-	-	-	1015	69.98	430	29.65	290	19.99
2924	-	-	-	-	1525	105.15	650	44.82	290	19.99
2926	-	-	-	-	2540	175.13	1080	74.46	750	51.71

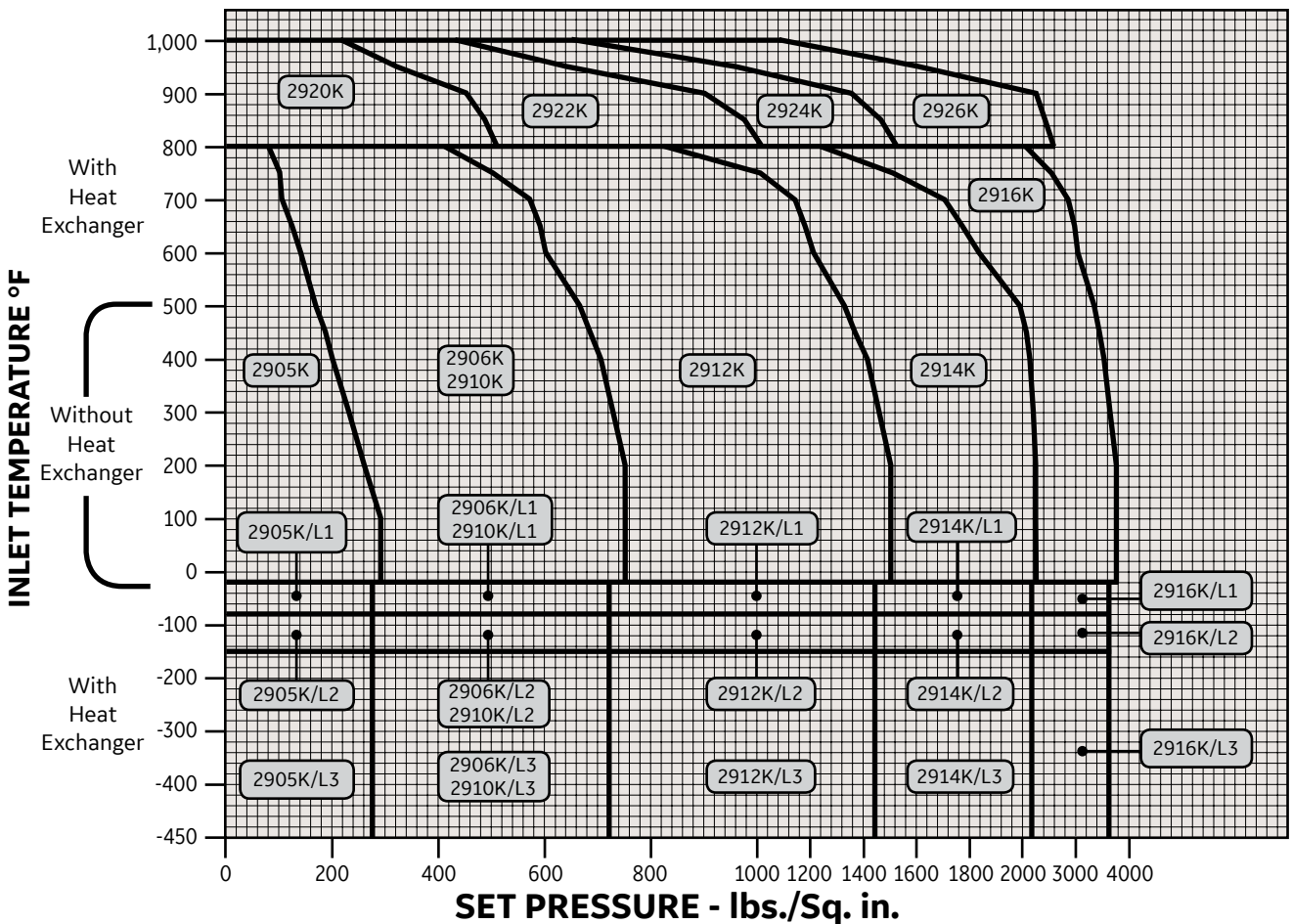

Pressure/Temperature

Selection Table for Vapors, Gases and Liquids

2900 Series Valve, L Orifice - ASME Area: 3.317 in² (21.400 cm²)

Pressure Temperature Ratings for "L" Orifice										
Valve Type	ASME Ratings, L Orifice - (3.317 in ² (21.400 cm ²) Actual)								Backpressure Limits @ 100°F (37.8°C)	
	Standard Material of Construction								Conventional & Bellows	
	-20 to 100°F (-28.9 to 37.8°C)		450°F (232.2°C)		800°F (426.7°C)		1000°F (537.8°C)			
	psig	barg	psig	barg	psig	barg	psig	barg	psig	barg
2905	290	19.99	185	12.75	80	5.51	-	-	280	19.30
2906	290	19.99	685	47.22	410	28.26	-	-	290	19.99
2910	750	51.71	685	47.22	410	28.26	-	-	290	19.99
2912	1500	103.42	1365	94.11	825	56.88	-	-	290	19.99
2914	2250	155.13	2050	141.34	1235	85.15	-	-	290	19.99
2916	3750	258.55	3420	235.80	2055	141.68	-	-	290	19.99
2920	-	-	-	-	510	35.16	215	14.82	290	19.99
2922	-	-	-	-	1015	69.98	430	29.64	290	19.99
2924	-	-	-	-	1525	105.14	650	44.81	290	19.99
2926	-	-	-	-	2540	175.12	1080	74.46	290	19.99

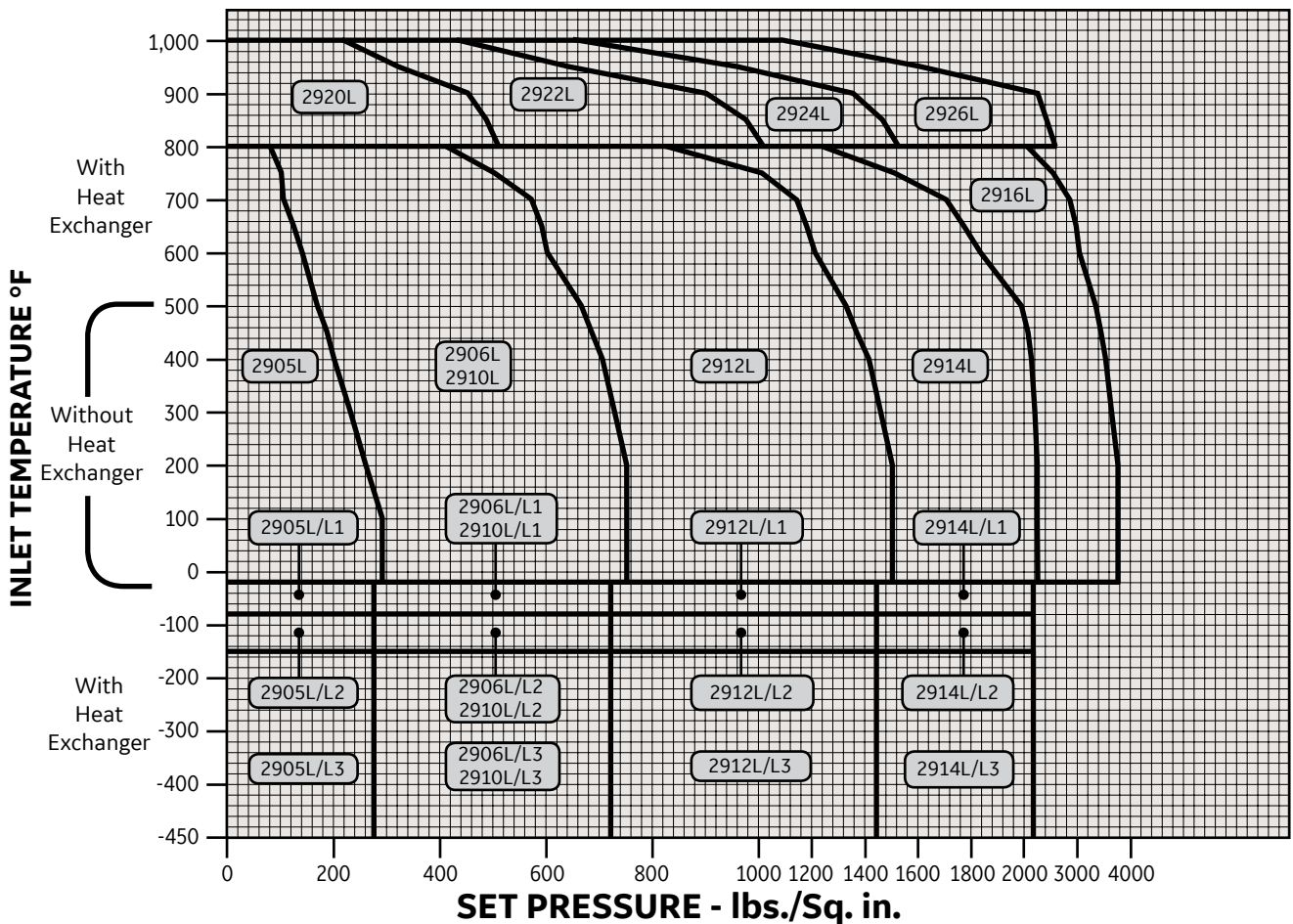

Pressure/Temperature

Selection Table for Vapors, Gases and Liquids

2900 Series Valve, M Orifice - ASME Area: 4.186 in² (27.006 cm²)

Pressure Temperature Ratings for "M" Orifice										
Valve Type	ASME Ratings, M Orifice - (4.186 in ² (27.006 cm ²) Actual)								Backpressure Limits @ 100°F (37.8°C)	
	Standard Material of Construction								Conventional & Bellows	
	-20 to 100°F (-28.9 to 37.8°C)		450°F (232.2°C)		800°F (426.7°C)		1000°F (537.8°C)			
	psig	barg	psig	barg	psig	barg	psig	barg	psig	barg
2905	290	19.99	185	12.75	80	5.51	-	-	280	19.30
2906	750	51.71	685	47.22	410	28.26	-	-	290	19.99
2910	750	51.71	685	47.22	410	28.26	-	-	290	19.99
2912	1500	103.42	1365	94.11	825	56.88	-	-	290	19.99
2914	2250	155.13	2050	141.34	1235	85.15	-	-	290	19.99
2920	-	-	-	-	510	35.16	215	14.82	290	19.99
2922	-	-	-	-	1015	69.98	430	29.64	290	19.99
2924	-	-	-	-	1525	105.14	650	44.81	290	19.99

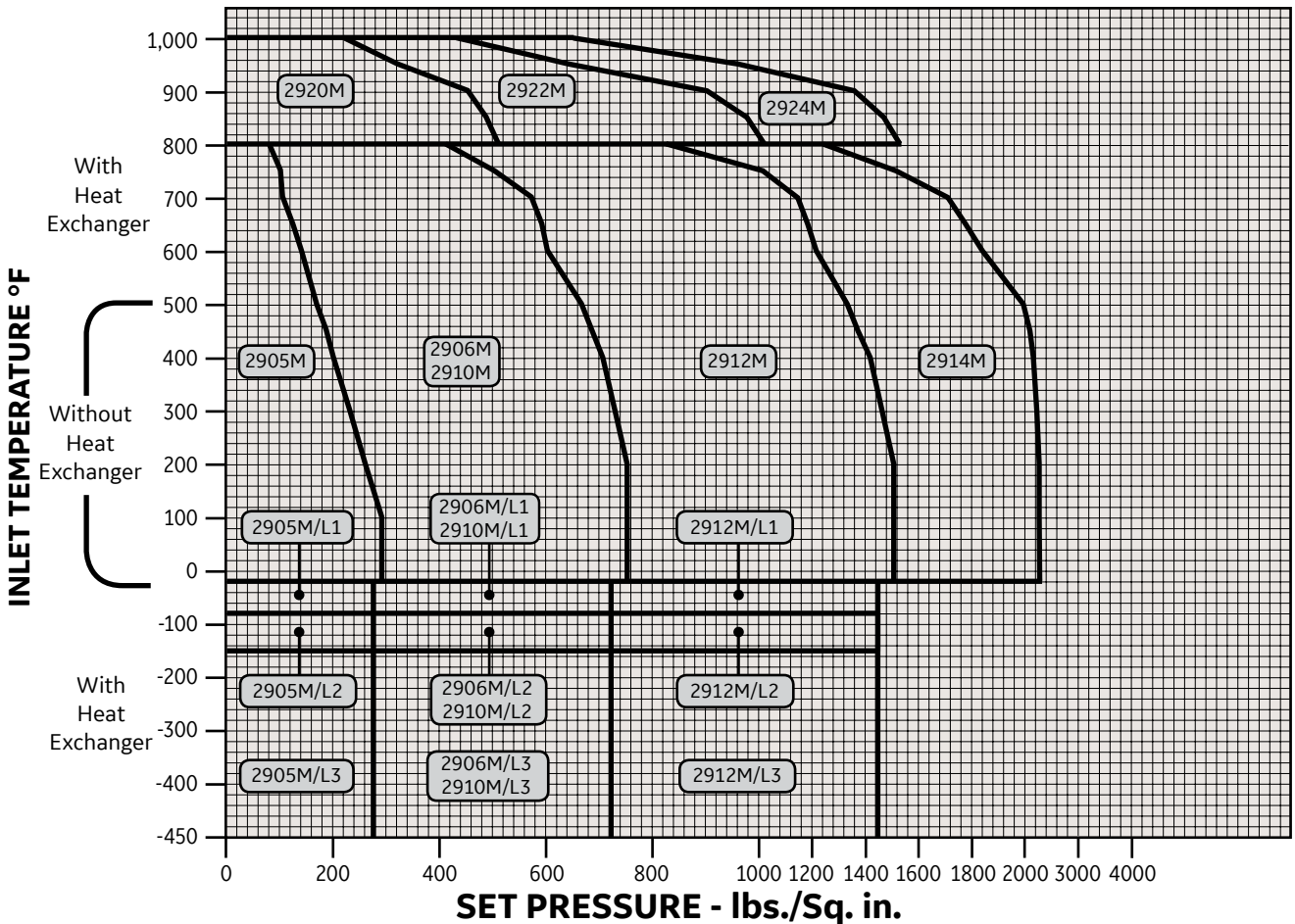

Pressure/Temperature

Selection Table for Vapors, Gases and Liquids

2900 Series Valve, N Orifice - ASME Area: 5.047 in² (32.561 cm²)

Pressure Temperature Ratings for "N" Orifice										
Valve Type	ASME Ratings, N Orifice - (5.047 in ² (32.561 cm ²) Actual)								Backpressure Limits @ 100°F (37.8°C)	
	Standard Material of Construction								Conventional & Bellows	
	-20 to 100 °F (-28.9 to 37.8°C)		450°F (232.2°C)		800°F (426.7°C)		1000°F (537.8°C)			
	psig	barg	psig	barg	psig	barg	psig	barg	psig	barg
2905	290	19.99	185	12.75	80	5.51	-	-	280	19.30
2906	750	51.71	685	47.22	410	28.26	-	-	290	19.99
2910	750	51.71	685	47.22	410	28.26	-	-	290	19.99
2912	1500	103.42	1365	94.11	825	56.88	-	-	290	19.99
2914	2250	155.13	2050	141.34	1235	85.15	-	-	290	19.99
2920	-	-	-	-	510	35.16	215	14.82	290	19.99
2922	-	-	-	-	1015	69.98	430	29.64	290	19.99
2924	-	-	-	-	1525	105.14	650	44.81	290	19.99

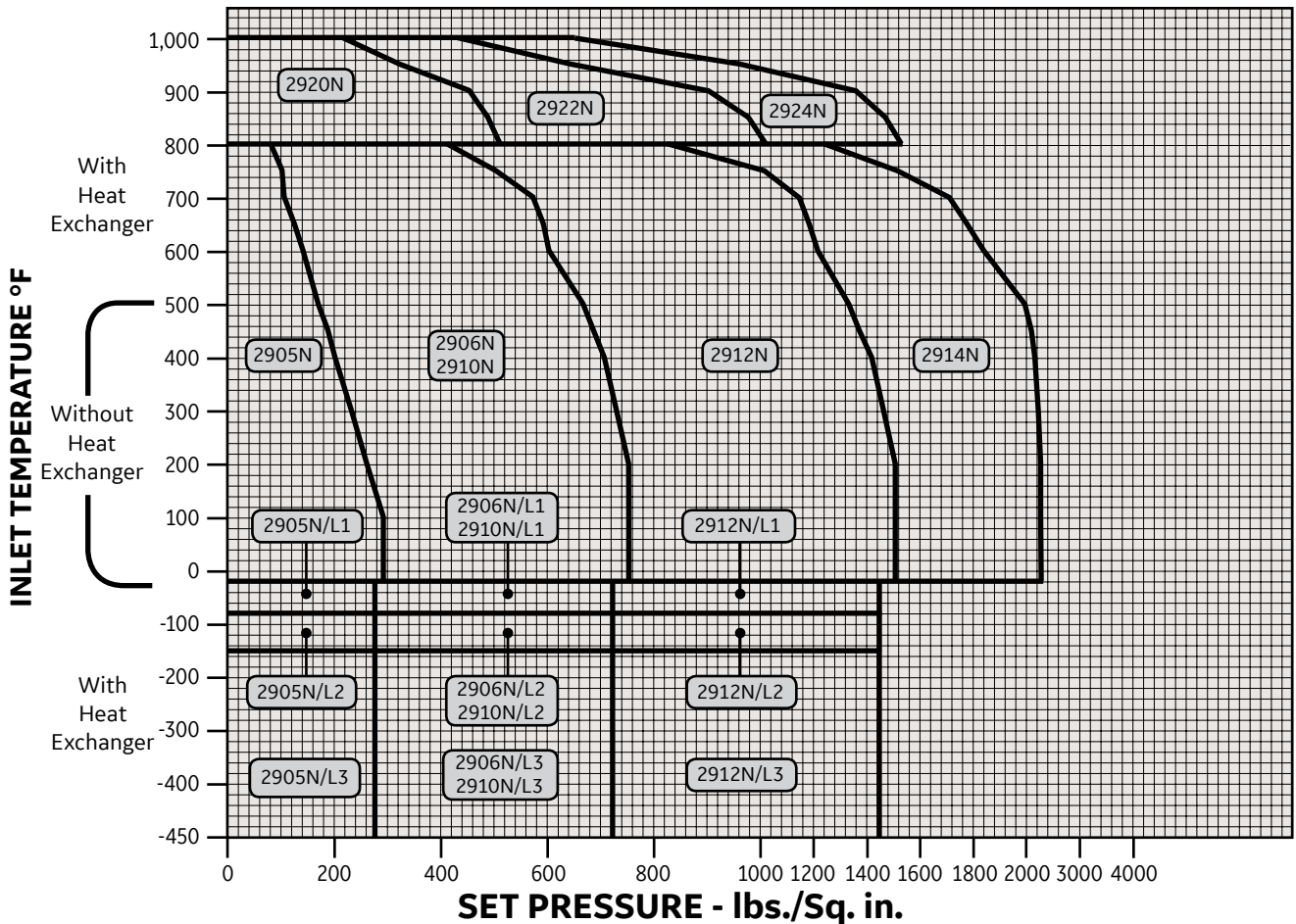

Pressure/Temperature

Selection Table for Vapors, Gases and Liquids

2900 Series Valve, P Orifice - ASME Area: 7.417 in² (47.852 cm²)

Pressure Temperature Ratings for "P" Orifice										
Valve Type	ASME Ratings, P Orifice - (7.417 in ² (47.852 cm ²) Actual)								Backpressure Limits @ 100°F (37.8°C)	
	Standard Material of Construction								Conventional & Bellows	
	-20 to 100 °F (-28.9 to 37.8°C)		450°F (232.2°C)		800°F (426.7°C)		1000°F (537.8°C)			
	psig	barg	psig	barg	psig	barg	psig	barg	psig	barg
2905	290	19.99	185	12.75	80	5.51	-	-	280	19.30
2906	750	51.71	685	47.22	410	28.26	-	-	290	19.99
2910	750	51.71	685	47.22	410	28.26	-	-	290	19.99
2912	1500	103.42	1365	94.11	825	56.88	-	-	290	19.99
2914	2250	155.13	2050	141.34	1235	85.15	-	-	290	19.99
2920	-	-	-	-	510	35.16	215	14.82	290	19.99
2922	-	-	-	-	1015	69.98	430	29.64	290	19.99
2924	-	-	-	-	1525	105.14	650	44.81	290	19.99

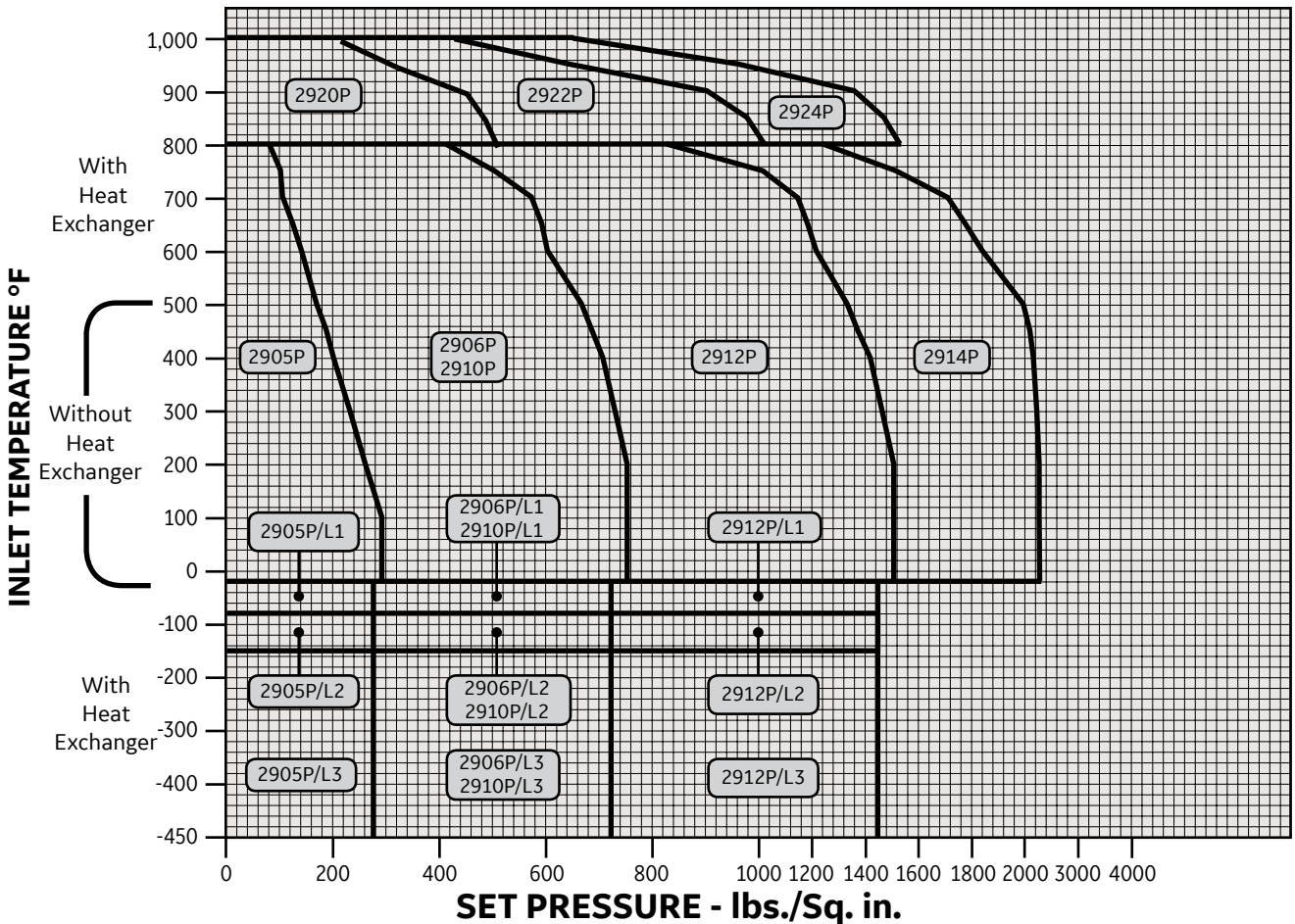

Pressure/Temperature

Selection Table for Vapors, Gases and Liquids

2900 Series Valve, Q Orifice - ASME Area: 12.850 in² (82.903 cm²)

Pressure Temperature Ratings for "Q" Orifice										
Valve Type	ASME Ratings, Q Orifice - (12.850 in ² (82.903 cm ²) Actual)								Backpressure Limits @ 100°F (37.8°C)	
	Standard Material of Construction								Conventional & Bellows	
	-20 to 100 °F (-28.9 to 37.8°C)		450°F (232.2°C)		800°F (426.7°C)		1000°F (537.8°C)			
	psig	barg	psig	barg	psig	barg	psig	barg	psig	barg
2905	290	19.99	185	12.75	80	5.51	-	-	280	19.30
2906	750	51.71	685	47.22	410	28.26	-	-	290	19.99
2910	750	51.71	685	47.22	410	28.26	-	-	290	19.99
2912	1500	103.42	1365	94.11	825	56.88	-	-	290	19.99
2920	-	-	-	-	510	35.16	215	14.82	290	19.99
2922	-	-	-	-	1015	69.98	430	29.64	290	19.99

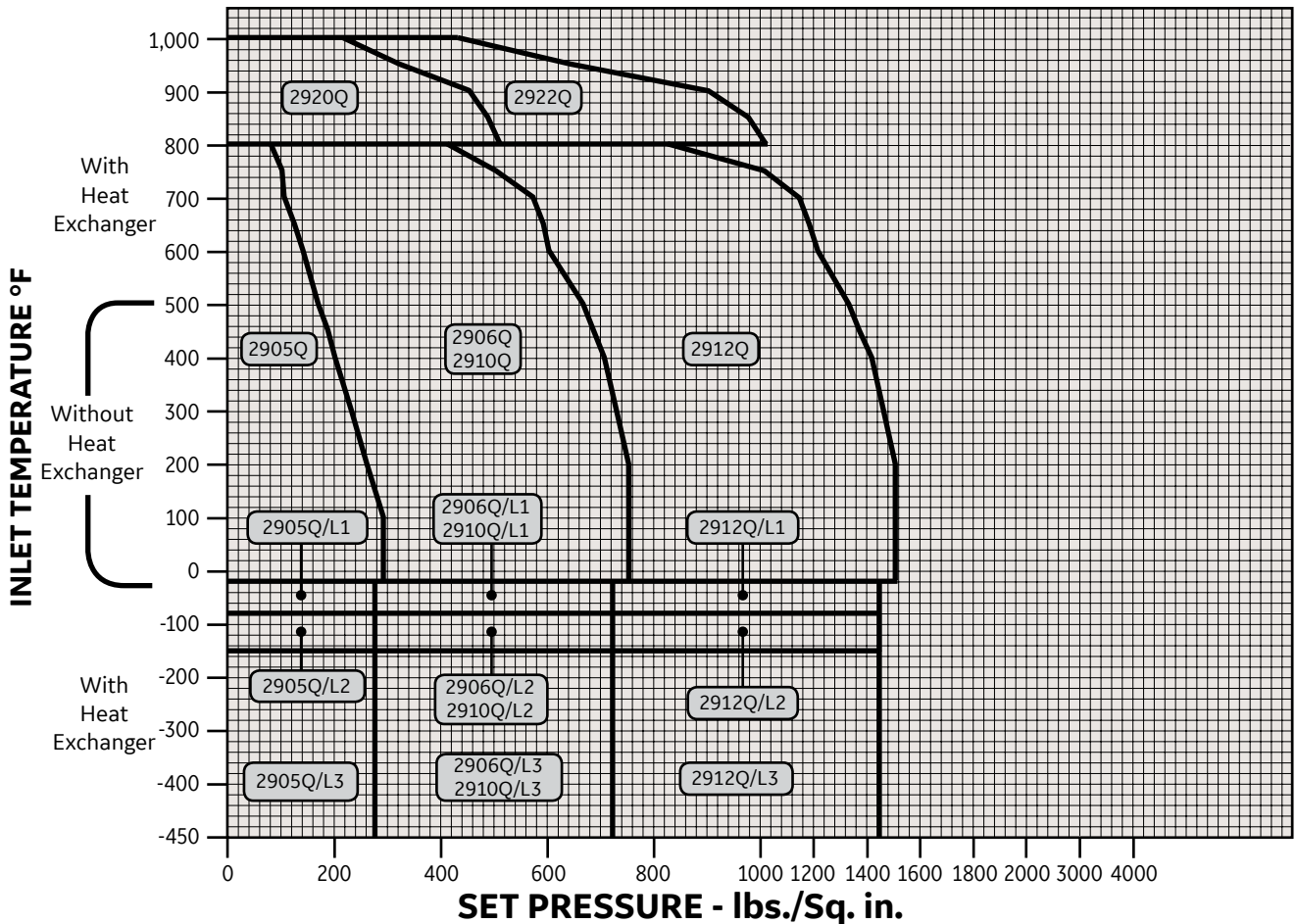

Pressure/Temperature

Selection Table for Vapors, Gases and Liquids

2900 Series Valve, R Orifice - ASME Area: 18.600 in² (120.000 cm²)

Pressure Temperature Ratings for "R" Orifice										
Valve Type	ASME Ratings, R Orifice - (18.600 in ² (120.000 cm ²) Actual)								Backpressure Limits @ 100°F (37.8°C)	
	Standard Material of Construction								Conventional & Bellows	
	-20 to 100 °F (-28.9 to 37.8°C)		450°F (232.2°C)		800°F (426.7°C)		1000°F (537.8°C)			
	psig	barg	psig	barg	psig	barg	psig	barg	psig	barg
2905	290	19.99	185	12.75	80	5.51	-	-	280	19.30
2906	750	51.71	685	47.22	410	28.26	-	-	290	19.99
2910	750	51.71	685	47.22	410	28.26	-	-	290	19.99
2912	1500	103.42	1365	94.11	825	56.88	-	-	290	19.99
2920	-	-	-	-	510	35.16	215	14.82	290	19.99
2922	-	-	-	-	1015	69.98	430	29.64	290	19.99

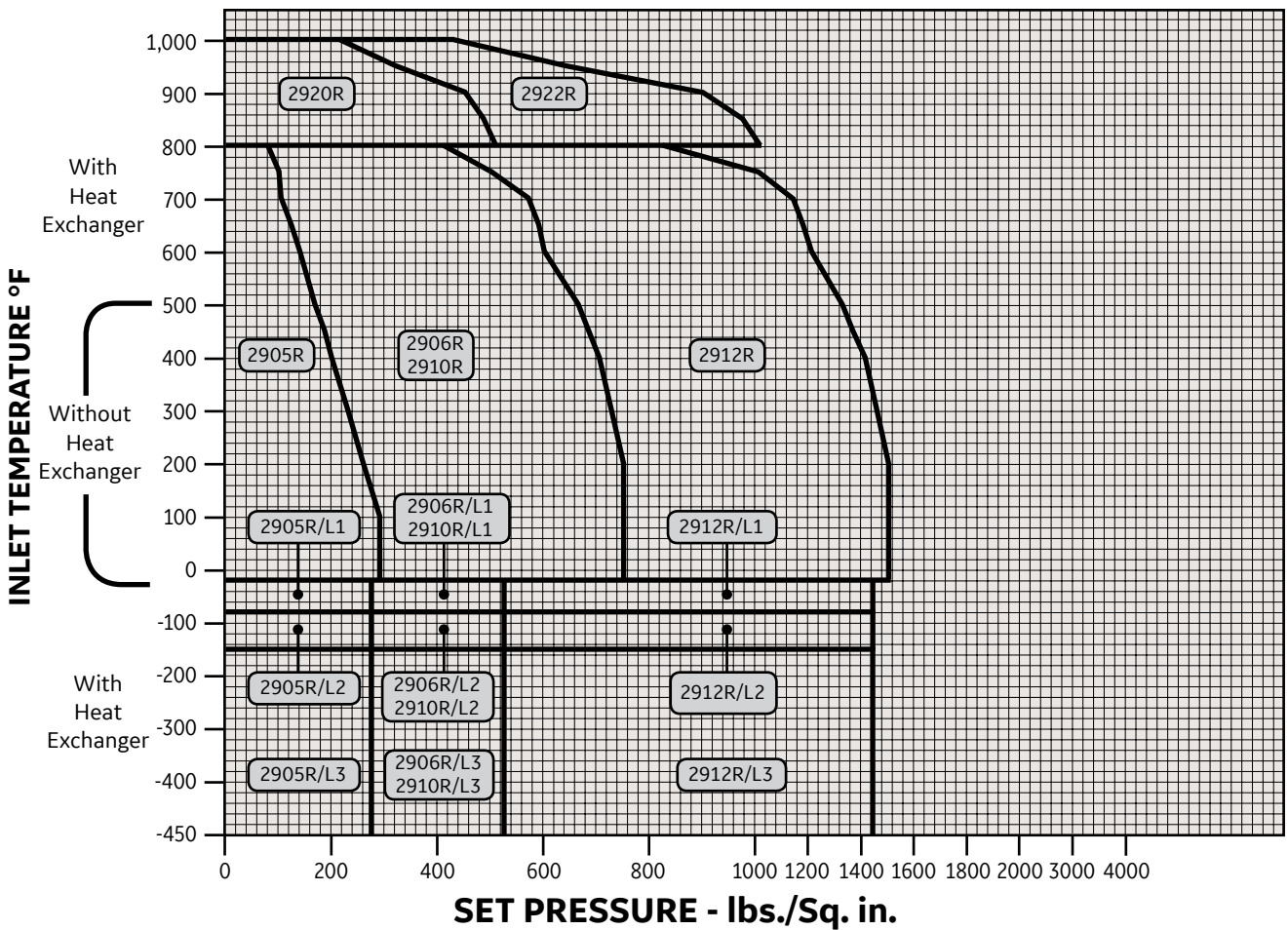

Pressure/Temperature

Selection Table for Vapors, Gases and Liquids

2900 Series Valve, T Orifice - ASME Area: 30.210 in² (194.903 cm²)

Pressure Temperature Ratings for "T" Orifice										
Valve Type	ASME Ratings, T Orifice - (30.210 in ² (194.903 cm ²) Actual)								Backpressure Limits @ 100°F (37.8°C)	
	Standard Material of Construction								Conventional & Bellows	
	-20 to 100 °F (-28.9 to 37.8°C)		450°F (232.2°C)		800°F (426.7°C)		1000°F (537.8°C)			
	psig	barg	psig	barg	psig	barg	psig	barg	psig	barg
2905	290	19.99	185	12.75	80	5.51	-	-	280	19.30
2906	750	51.71	685	47.22	410	28.26	-	-	290	19.99
2910	750	51.71	685	47.22	410	28.26	-	-	290	19.99
2912 1	905	62.39	905	62.39	825	56.88	-	-	290	19.99
2920	-	-	-	-	510	35.16	215	14.82	290	19.99
2922 1	-	-	-	-	905	62.39	430	29.64	290	19.99

Notes:

1. Pressure/Temperature rating is limited by the base to coverplate bolting (B7 material).

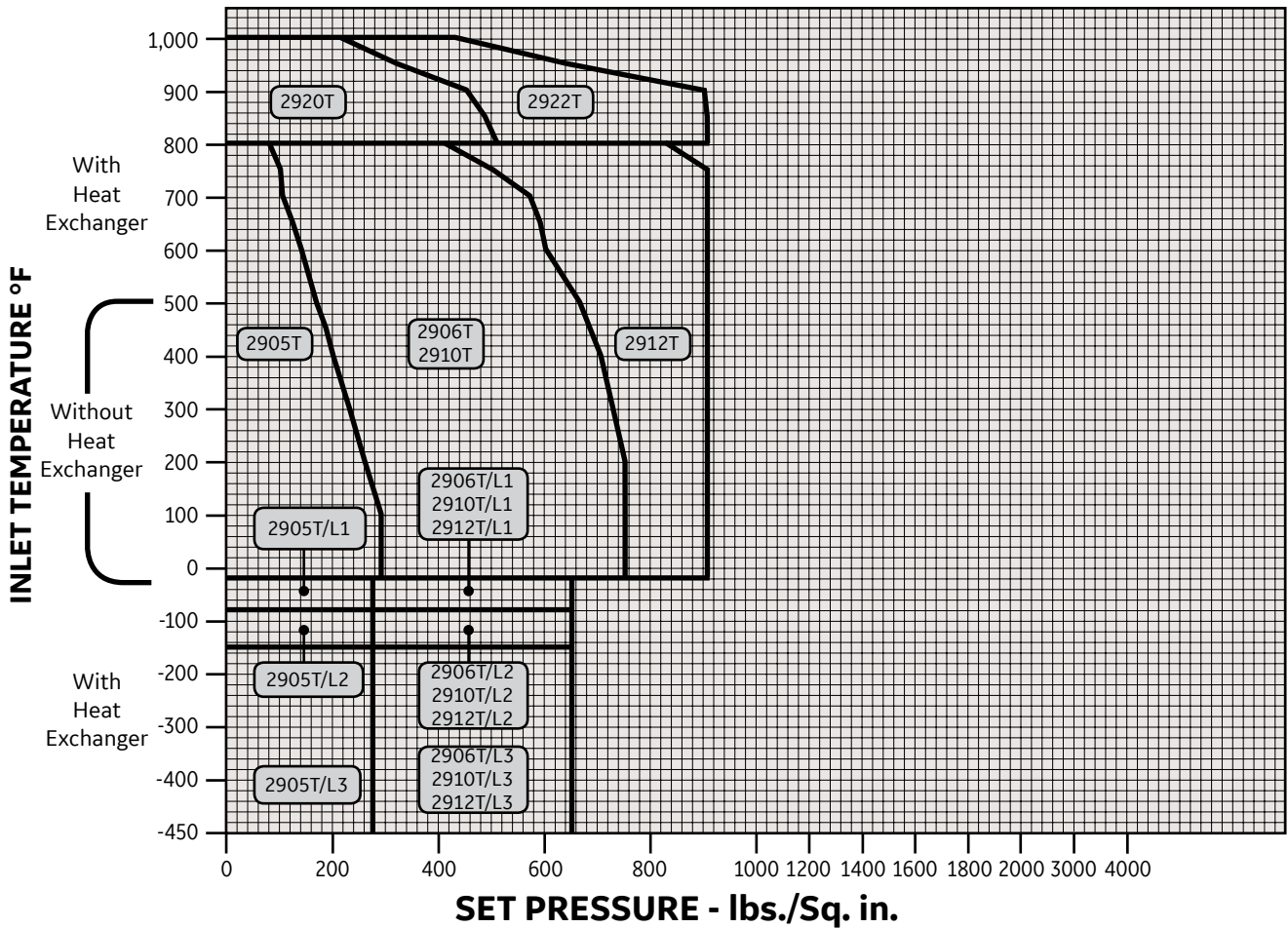

Pressure/Temperature

Selection Table for Vapors, Gases and Liquids

2900 Series Valve, U Orifice - ASME Area: 35.000 in² (225.806 cm²)

Pressure Temperature Ratings for "U" Orifice										
Valve Type	ASME Ratings, U Orifice - (35.000 in ² (225.806 cm ²) Actual)								Backpressure Limits @ 100°F (37.8°C)	
	Standard Material of Construction								Conventional & Bellows	
	-20 to 100 °F (-28.9 to 37.8°C)		450°F (232.2°C)		800°F (426.7°C)		1000°F (537.8°C)			
	psig	barg	psig	barg	psig	barg	psig	barg	psig	barg
2905	290	19.99	185	12.75	80	5.51	-	-	280	19.30
2906	750	51.71	685	47.22	410	28.26	-	-	290	19.99
2910	750	51.71	685	47.22	410	28.26	-	-	290	19.99
2912 ¹	905	62.39	905	62.39	825	56.88	-	-	290	19.99
2920	-	-	-	-	510	35.16	215	14.82	290	19.99
2922 ¹	-	-	-	-	905	62.39	430	29.64	290	19.99

Notes:

1. Pressure/Temperature rating is limited by the base to coverplate bolting (B7 material).

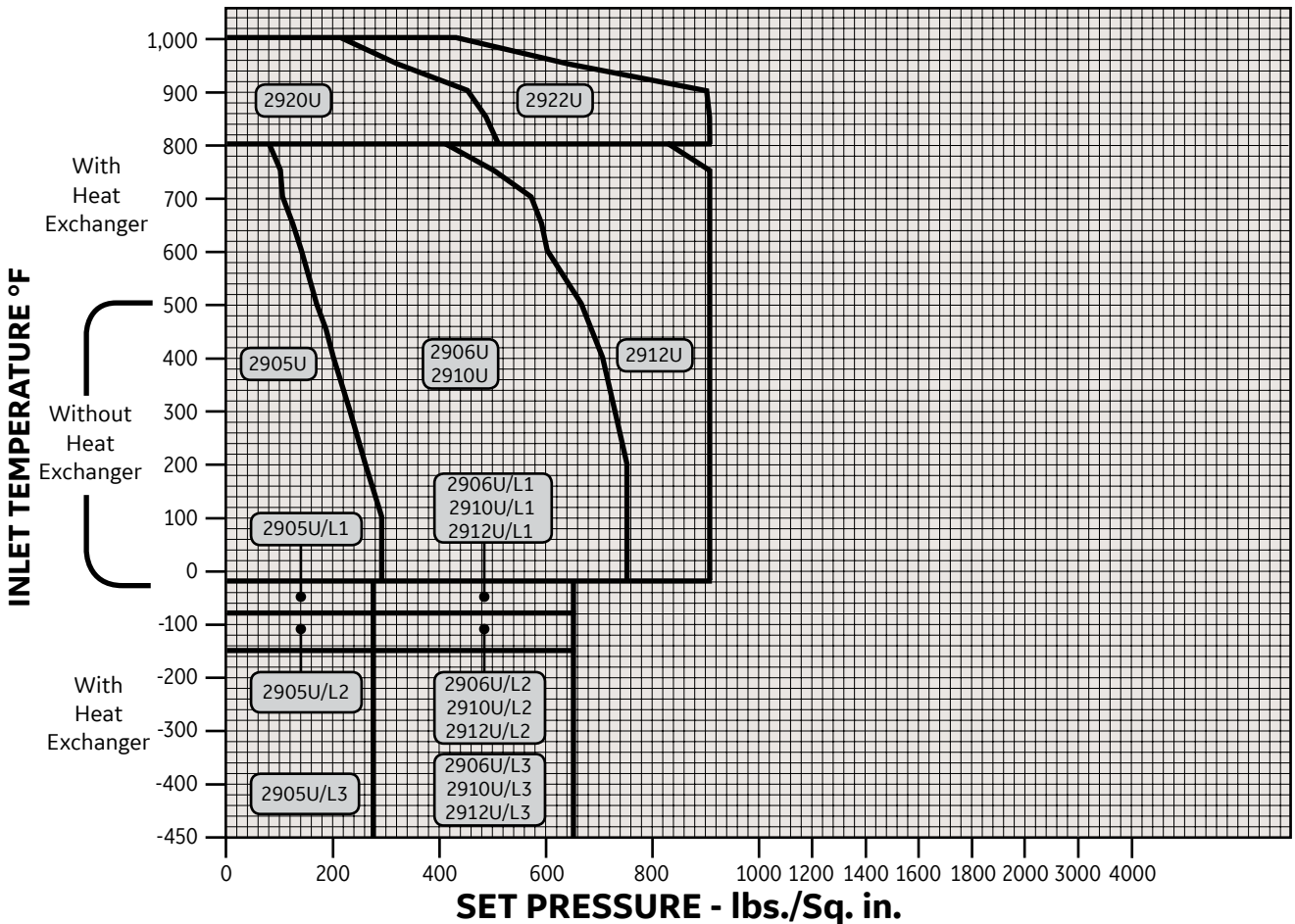

Pressure/Temperature

Selection Table for Vapors, Gases and Liquids

2900 Series Valve, V Orifice - ASME Area: 50.260 in² (324.257 cm²)

Pressure Temperature Ratings for "V" Orifice										
Valve Type	ASME Ratings, V Orifice - (50.260 in ² (324.257 cm ²) Actual)								Backpressure Limits @ 100°F (37.8°C)	
	Standard Material of Construction								Conventional & Bellows	
	-20 to 100 °F (-28.9 to 37.8°C)		450°F (232.2°C)		800°F (426.7°C)		1000°F (537.8°C)			
	psig	barg	psig	barg	psig	barg	psig	barg	psig	barg
2905	290	19.99	185	12.75	80	5.51	-	-	280	19.30
29061	675	46.53	675	46.53	410	28.26	-	-	290	19.99
29101	675	46.53	675	46.53	410	28.26	-	-	290	19.99
2920	-	-	-	-	510	35.16	215	14.82	290	19.99

Notes:

1. Pressure/Temperature rating is limited by the base to coverplate bolting (B7 material).

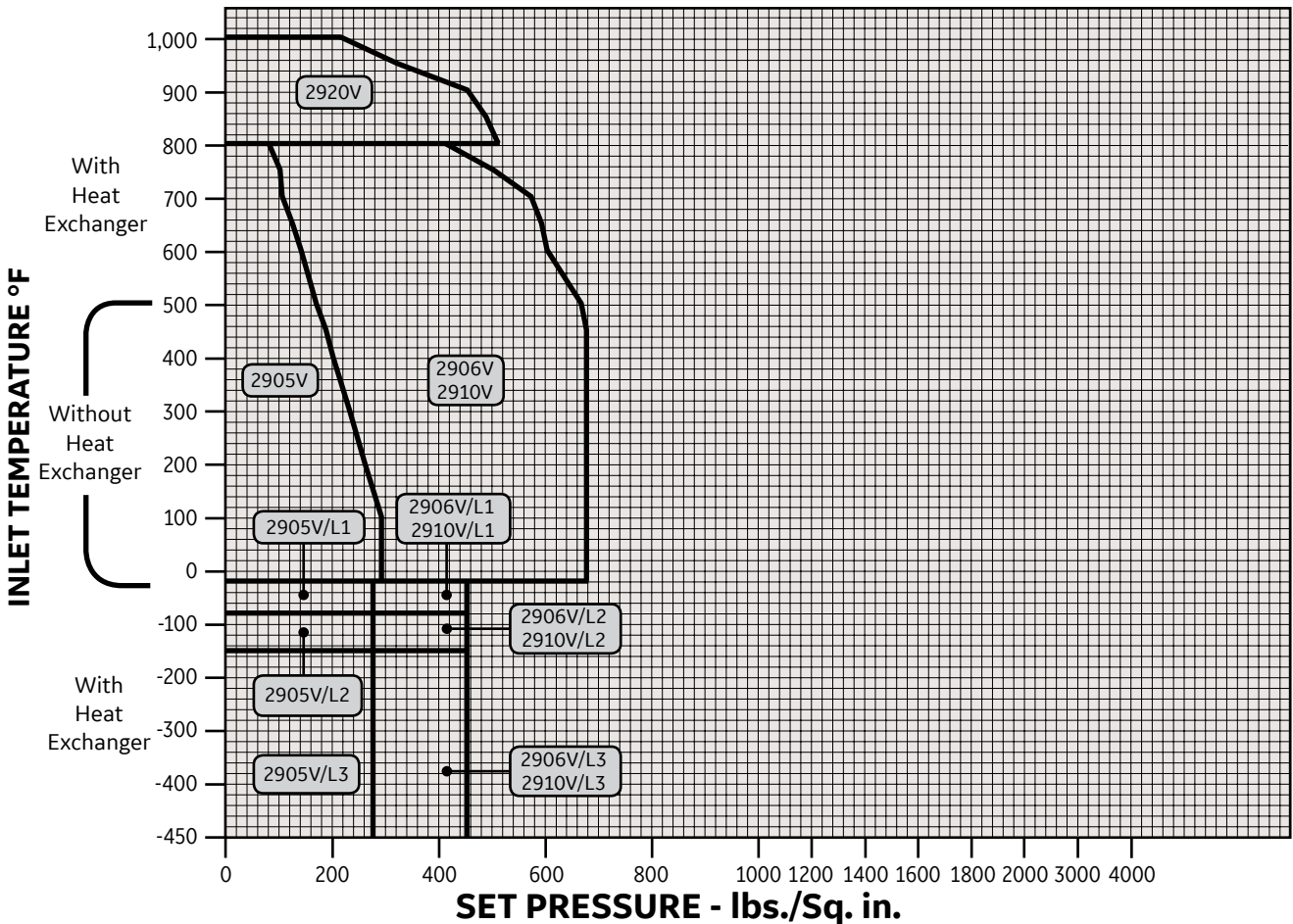

Pressure/Temperature

Selection Table for Vapors, Gases and Liquids

2900 Series Valve, W Orifice - ASME Area: 78.996 in² (509.651 cm²)

Pressure Temperature Ratings for "W" Orifice										
Valve Type	ASME Ratings, W Orifice - (78.996 in ² (509.651 cm ²) Actual)								Backpressure Limits @ 100°F (37.8°C)	
	Standard Material of Construction								Conventional & Bellows	
	-20 to 100 °F (-28.9 to 37.8°C)		450°F (232.2°C)		800°F (426.7°C)		1000°F (537.8°C)			
	psig	barg	psig	barg	psig	barg	psig	barg	psig	barg
2905	290	19.99	185	12.76	80	5.52	-	-	280	19.31
2906 ¹	535	36.89	535	36.89	410	28.27	-	-	290	19.99
2910 ¹	535	36.89	535	36.89	410	28.27	-	-	290	19.99
2920	-	-	-	-	510	35.16	215	14.82	290	19.99

Notes:

1. Pressure/Temperature rating is limited by the base to coverplate bolting (B7 material).

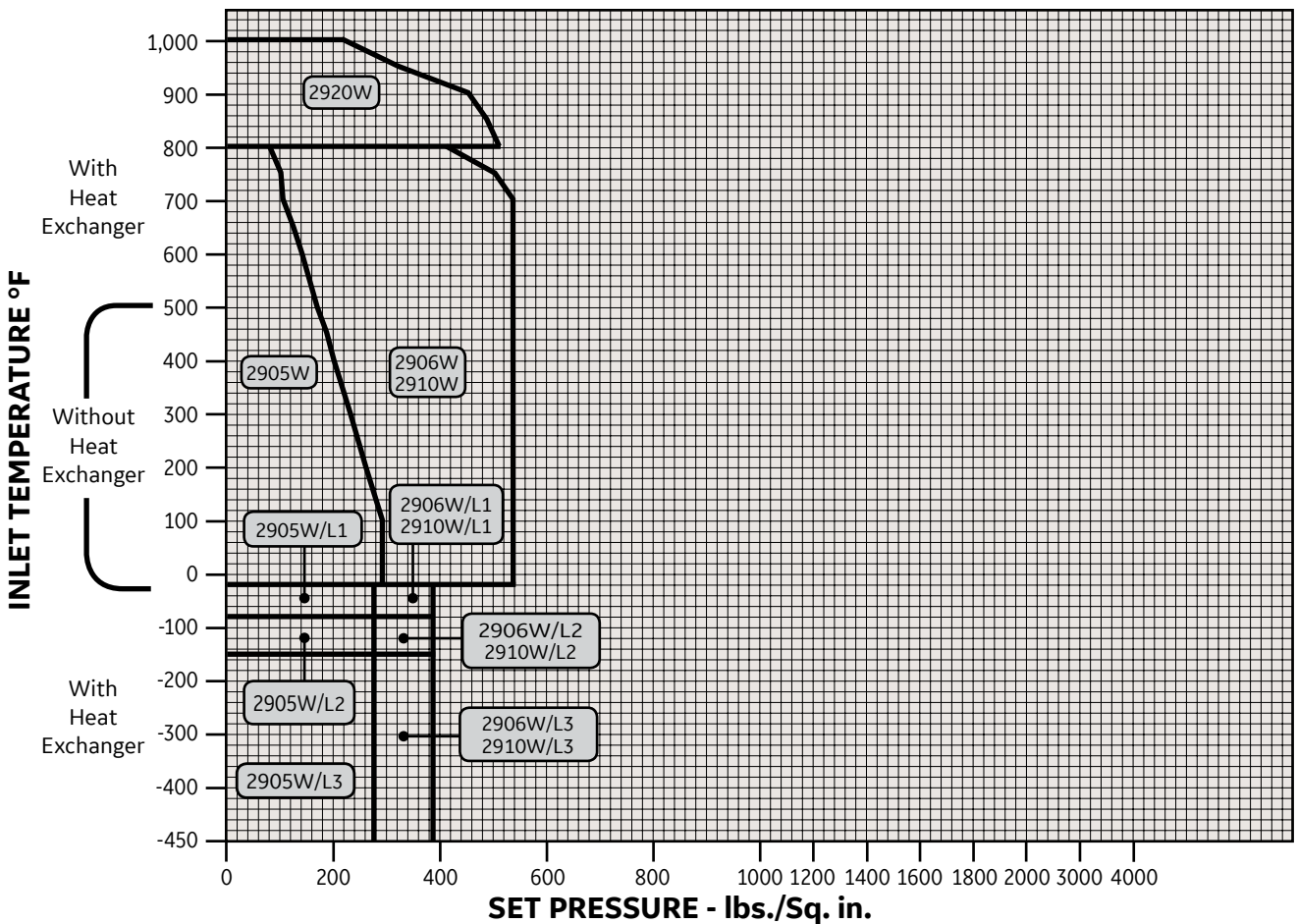

Capacities

Steam

Valve Capacity for ASME B&PV Code Section VIII, for Saturated Steam¹

Based at 10% overpressure or 3 psig (0.21 barg), whichever is greater, showing 90% of actual capacity in accordance with latest ASME Code requirements.

Orifice Designation	N		P		Q		R		T		U		V		W		
	in ²	cm ²	in ²	cm ²	in ²	cm ²	in ²	cm ²	in ²	cm ²	in ²	cm ²	in ²	cm ²	in ²	cm ²	
	5.047	32.561	7.417	47.852	12.850	82.903	18.600	120.000	30.210	194.903	35.000	225.806	50.260	324.257	78.996	509.651	
Set Pressure	Orifice Capacity																
psig	barg	lb/hr	kg/hr	lb/hr	kg/hr	lb/hr	kg/hr	lb/hr	kg/hr	lb/hr	kg/hr	lb/hr	kg/hr	lb/hr	kg/hr	lb/hr	kg/hr
15	1.03	7266	3295.80	10679	4843.91	18502	8392.37	26781	12147.66	43498	19730.36	50395	22858.79	72367	32825.12	113743	51592.96
20	1.37	8378	3800.20	12312	5584.63	21331	9675.58	30876	14005.12	50149	22747.21	58100	26353.72	83432	37844.12	131135	59481.84
30	2.06	10600	4808.08	15578	7066.06	26989	12242.01	39066	17720.04	63451	28780.89	73512	33344.48	105563	47882.57	165919	75259.60
40	2.75	13045	5917.11	19170	8695.37	33213	15065.16	48075	21806.45	78084	35418.31	90464	41033.78	129907	58924.83	204181	92614.95
50	3.44	15489	7025.69	22763	10325.12	39437	17888.32	57084	25892.87	92716	42055.27	107417	48723.53	154251	69967.08	242443	109970.30
60	4.13	17934	8134.73	26355	11954.43	45661	20711.48	66093	29979.28	107348	48692.24	124369	56412.83	178595	81009.33	280706	127326.11
70	4.82	20378	9243.31	29948	13584.19	51885	23534.64	75102	34065.70	121981	55329.65	141322	64102.59	202938	92051.13	318968	144681.46
80	5.51	22823	10352.34	33540	15213.49	58109	26357.80	84111	38152.11	136613	61966.62	158274	71791.88	227282	103093.39	357230	162036.81
90	6.20	25267	11460.92	37133	16843.25	64333	29180.96	93120	42238.52	151246	68604.04	175227	79481.64	251626	114135.64	395493	179392.62
100	6.89	27712	12569.95	40725	18472.55	70557	32004.12	102129	46324.94	165878	75241.00	192179	87170.93	275970	125177.89	433755	196747.97
120	8.27	32601	14787.57	47910	21731.61	83005	37650.44	120147	54497.77	195143	88515.38	226084	102549.98	324657	147261.95	510280	231459.13
140	9.65	37490	17005.18	55095	24990.67	95453	43296.76	138166	62671.05	224408	101789.76	259989	117929.03	373345	169346.45	586804	266169.83
160	11.03	42379	19222.79	62280	28249.73	107901	48943.07	156184	70843.88	253673	115064.14	293894	133308.08	422033	191430.96	663329	300880.99
180	12.41	47268	21440.41	69465	31508.80	120349	54589.39	174202	79016.70	282938	128338.53	327799	148687.14	470720	213515.01	739853	335591.70
200	13.78	52157	23658.02	76650	34767.86	132797	60235.71	192220	87189.53	312203	141612.91	361704	164066.19	519408	235599.52	816378	370302.86
220	15.16	57046	25875.63	83835	38026.92	145245	65882.03	210238	95362.36	341467	154886.84	395609	179445.24	568095	257683.57	892903	405014.01
240	16.54	61936	28093.70	91020	41285.98	157693	71528.35	228256	103535.19	370732	168161.22	429515	194824.74	616783	279768.08	969427	439724.72
260	17.92	66825	30311.31	98205	44545.04	170141	77174.66	246274	111708.01	399997	181435.60	463420	210203.79	665471	301852.59	1045927	474435.88
280	19.30	71714	32528.93	105390	47804.10	182589	82820.98	264292	119880.84	429262	194709.98	497325	225582.84	714158	323936.64	1122476	509146.58
300	20.68	76603	34746.54	112575	51063.16	195037	88467.30	282310	128053.67	458527	207984.36	531230	240961.89	762846	346021.15	1199001	543857.74
320	22.06	81492	36964.15	119760	54322.23	207485	94113.62	300328	136226.50	487792	221258.74	565135	256340.94	811534	368105.65	1275526	578568.90
340	23.44	86381	39181.77	126945	57581.29	219933	99759.94	318347	144399.78	517057	234533.13	599040	271719.99	860221	390189.71	1352050	613279.60
360	24.82	91270	41399.38	134130	60840.35	232381	105406.26	336365	152572.61	546322	247807.51	632945	287099.04	908909	412274.21	1428575	647990.76
380	26.20	96159	43616.99	141315	64099.41	244829	111052.57	354383	160745.44	575586	261081.44	666850	302478.09	957596	434358.27	1505099	682701.47
400	27.57	101048	45834.60	148500	67358.47	257277	116698.89	372401	168918.26	604851	274355.82	700755	317857.14	1006284	456442.77	1581624	717412.63
420	28.95	105938	48052.67	155685	70617.53	269725	122345.21	390419	177091.09	634116	287630.20	734660	333236.19	1054972	478527.28	1658149	752123.78
440	30.33	110827	50270.28	162869	73876.14	282173	127991.53	408437	185263.92	663381	300904.58	768565	348615.24	1103659	500611.33	1734673	786834.49
460	31.71	115716	52487.90	170054	77135.20	294621	133637.85	426455	193436.75	692646	314178.96	802470	363994.29	1152347	522695.84	1811198	821545.65
480	33.09	120605	54705.51	177239	80394.26	307069	139284.16	444473	201609.57	721911	327453.34	836375	379373.34	1201034	544779.89	1887722	856256.35
500	34.47	125494	56923.12	184424	83653.32	319517	144930.48	462491	209782.40	751176	340727.72	870280	394752.39	1249722	566864.40	1964247	890967.51
600	41.36	149939	68011.19	220349	99948.63	381757	173162.07	552582	250647.00	897500	407099.18	1039805	471647.65	1493160	677286.03	2346870	1064522.40
700	48.26	174385	79099.71	256274	116243.94	443997	201393.66	642672	291511.13	1043825	473471.09	1209330	548542.90	1736598	787707.65	—	—
800	55.15	198830	90187.78	292199	132539.25	506237	229625.26	732763	332375.73	1190149	539842.54	1378855	625438.15	—	—	—	—
900	62.05	223276	101276.30	328124	148834.55	568476	257856.39	822853	373239.87	1336473	606214.00	1548380	702333.40	—	—	—	—
1000	68.94	247722	112364.82	364048	165129.41	630716	286087.98	912944	414104.46	1482798	672585.90	1717905	779228.65	—	—	—	—
1100	75.84	272167	123452.88	399973	181424.71	692956	314319.58	1003034	454968.60	—	—	—	—	—	—	—	—
1200	82.73	296613	134541.40	435898	197720.02	755196	342551.17	1093125	495833.19	—	—	—	—	—	—	—	—
1300	89.63	321058	145629.47	471823	214015.33	817436	370782.76	1183215	536697.33	—	—	—	—	—	—	—	—
1400	96.52	345504	156717.99	507747	230310.18	879676	399014.35	1273306	577561.92	—	—	—	—	—	—	—	—
1423 ¹	98.11	351126	159268.09	516010	234058.21	893991	405507.52	1294027	586960.81	—	—	—	—	—	—	—	—
1500	103.42	371723	168610.73	546279	247788.00	946432	429294.36	1369933	621391.20	—	—	—	—	—	—	—	—
2000	137.89	513956	233126.54	755302	342599.25	1308566	593555.59	1894111	859154.35	—	—	—	—	—	—	—	—
2500	172.36	680136	308504.52	999518	453373.77	—	—	—	—	—	—	—	—	—	—	—	—
2903 ^{1,2}	200.15	—	—	—	—	—	—	—	—	—	—	—	—	—	—	—	—

Notes:

1. The following Napier Factor is applied to the capacity of pressures between 1423 psig (98.11 barg) and 2903 psig (200.15 barg):

$$\left[\frac{0.1906 \times P_{psia} - 1000}{0.2292 \times P_{psia} - 1061} \right]$$

2. Maximum permissible set pressure on steam is 2903 psig (200.15 barg). Value has been interpolated.

Capacities

Air

Valve Capacity for ASME B&PV Code Section I, for Air																			
Based at 10% overpressure or 3 psig (0.21 barg), whichever is greater, showing 90% of actual capacity in accordance with latest ASME Code requirements. Units of ft ³ /min (m ³ /min) of air are at a temperature of 60°F (15.6°C).																			
Orifice Designation	D		E		F		G		H		J		K		L		M		
Orifice Area	in ²	cm ²	in ²	cm ²	in ²	cm ²	in ²	cm ²	in ²	cm ²	in ²	cm ²	in ²	cm ²	in ²	cm ²	in ²	cm ²	
	0.128	0.825	0.228	1.470	0.357	2.302	0.585	3.774	0.913	5.888	1.496	9.652	2.138	13.794	3.317	21.400	4.186	27.006	
Set Pressure		Orifice Capacity																	
psig	barg	ft ³ /min	m ³ /min	ft ³ /min	m ³ /min	ft ³ /min	m ³ /min	ft ³ /min	m ³ /min	ft ³ /min	m ³ /min	ft ³ /min	m ³ /min	ft ³ /min	m ³ /min	ft ³ /min	m ³ /min	ft ³ /min	m ³ /min
15	1.03	65	1	116	3	183	5	300	8	468	13	767	21	1097	31	1702	48	2148	60
20	1.37	75	2	134	3	211	5	346	9	539	15	885	25	1264	35	1962	55	2476	70
30	2.06	95	2	170	4	267	7	437	12	683	19	1119	31	1600	45	2483	70	3133	88
40	2.75	117	3	209	5	328	9	538	15	840	23	1378	39	1969	55	3055	86	3856	109
50	3.44	139	3	249	7	390	11	639	18	998	28	1636	46	2338	66	3628	102	4578	129
60	4.13	161	4	288	8	451	12	740	20	1155	32	1894	53	2707	76	4200	118	5301	150
70	4.82	184	5	327	9	513	14	841	23	1313	37	2152	60	3076	87	4773	135	6023	170
80	5.51	206	5	367	10	575	16	942	26	1470	41	2411	68	3445	97	5346	151	6746	191
90	6.20	228	6	406	11	636	18	1043	29	1628	46	2669	75	3814	108	5918	167	7469	211
100	6.89	250	7	445	12	698	19	1144	32	1786	50	2927	82	4183	118	6491	183	8191	231
120	8.27	294	8	524	14	821	23	1346	38	2101	59	3444	97	4922	139	7636	216	9637	272
140	9.65	338	9	603	17	944	26	1548	43	2416	68	3960	112	5660	160	8781	248	11082	313
160	11.03	382	10	682	19	1067	30	1750	49	2731	77	4477	126	6398	181	9926	281	12527	354
180	12.41	426	12	760	21	1190	33	1952	55	3046	86	4993	141	7136	202	11072	313	13972	395
200	13.78	471	13	839	23	1314	37	2154	60	3361	95	5510	156	7874	222	12217	345	15417	436
220	15.16	515	14	918	25	1437	40	2356	66	3676	104	6026	170	8612	243	13362	378	16863	477
240	16.54	559	15	996	28	1560	44	2558	72	3991	113	6543	185	9351	264	14507	410	18308	518
260	17.92	603	17	1075	30	1683	47	2760	78	4307	121	7059	199	10089	285	15652	443	19753	559
280	19.30	647	18	1154	32	1806	51	2962	83	4622	130	7576	214	10827	306	16798	475	21198	600
300	20.68	691	19	1232	34	1930	54	3163	89	4937	139	8092	229	11565	327	17943	508	22644	641
320	22.06	736	20	1311	37	2053	58	3365	95	5252	148	8609	243	12303	348	19088	540	24089	682
340	23.44	780	22	1390	39	2176	61	3567	101	5567	157	9125	258	13041	369	20233	572	25534	723
360	24.82	824	23	1468	41	2299	65	3769	106	5882	166	9642	273	13779	390	21378	605	26979	763
380	26.20	868	24	1547	43	2422	68	3971	112	6197	175	10158	287	14518	411	22524	637	28424	804
400	27.57	912	25	1626	46	2546	72	4173	118	6512	184	10675	302	15256	432	23669	670	29870	845
420	28.95	956	27	1704	48	2669	75	4375	123	6827	193	11191	316	15994	452	24814	702	31315	886
440	30.33	1000	28	1783	50	2792	79	4577	129	7143	202	11708	331	16732	473	25959	735	32760	927
460	31.71	1045	29	1862	52	2915	82	4779	135	7458	211	12224	346	17470	494	27104	767	34205	968
480	33.09	1089	30	1940	54	3038	86	4981	141	7773	220	12741	360	18208	515	28250	799	35651	1009
500	34.47	1133	32	2019	57	3161	89	5183	146	8088	229	13257	375	18946	536	29395	832	37096	1050
600	41.36	1354	38	2413	68	3777	106	6193	175	9663	273	15840	448	22637	641	35121	994	44322	1255
700	48.26	1575	44	2806	79	4393	124	7202	203	11239	318	18422	521	26328	745	40847	1156	51548	1459
800	55.15	1795	50	3199	90	5009	141	8212	232	12815	362	21004	594	30019	850	46573	1318	58774	1664
900	62.05	2016	57	3593	101	5625	159	9222	261	14390	407	23587	667	33709	954	52299	1480	66000	1868
1000	68.94	2237	63	3986	112	6241	176	10231	289	15966	452	26169	741	37400	1059	58025	1643	73226	2073
1100	75.84	2458	69	4380	124	6857	194	11241	318	17541	496	28752	814	41091	1163	63751	1805	80453	2278
1200	82.73	2678	75	4773	135	7473	211	12251	346	19117	541	31334	887	44782	1268	69477	1967	87679	2482
1300	89.63	2899	82	5166	146	8089	229	13260	375	20692	585	33917	960	48472	1372	75203	2129	94905	2687
1400	96.52	3120	88	5560	157	8705	246	14270	404	22268	630	36499	1033	52163	1477	80929	2291	102131	2892
1500	103.42	3341	94	5953	168	9321	263	15280	432	23843	675	39082	1106	55854	1581	86655	2453	109357	3096
2000	137.89	4445	125	7920	224	12400	351	20328	575	31721	898	51994	1472	74308	2104	115285	3264	145488	4119
2500	172.36	5549	157	9887	279	15480	438	25377	718	39599	1121	64907	1837	92761	2626	143915	4075	181618	5142
3000	206.84	6653	188	11855	335	18560	525	30425	861	47477	1344	77819	2203	111215	3149	172545	4885	—	—
4000	275.79	8861	250	15789	447	24719	699	40522	1147	63232	1790	103644	2934	148122	4194	229805	6507	—	—
4250	293.02	9413	266	16772	474	26259	743	43046	1218	—	—	—	—	—	—	—	—	—	—
4500	310.26	9964	282	17756	502	27799	787	45570	1290	—	—	—	—	—	—	—	—	—	—
4750	327.50	10516	297	18739	530	29338	830	48095	1361	—	—	—	—	—	—	—	—	—	—
5000	344.73	11068	313	19723	558	30878	874	50619	1433	—	—	—	—	—	—	—	—	—	—
5250	361.97	11620	329	20706	586	32418	917	53143	1504	—	—	—	—	—	—	—	—	—	—
5500	379.21	12172	344	21690	614	33958	961	55667	1576	—	—	—	—	—	—	—	—	—	—
5750	396.44	12724	360	22673	642	35498	1005	58192	1647	—	—	—	—	—	—	—	—	—	—
6000	413.68	13276	375	23657	669	37038	1048	60716	1719	—	—	—	—	—	—	—	—	—	—
6250	430.92	13828	391	24640	697	38577	1092	63240	1790	—	—	—	—	—	—	—	—	—	—

Capacities

Air

Valve Capacity for ASME B&PV Code Section I, for Air																	
Based at 10% overpressure or 3 psig (0.21 barg), whichever is greater, showing 90% of actual capacity in accordance with latest ASME Code requirements.																	
Units of ft ³ /min (m ³ /min) of air are at a temperature of 60°F (15.6°C).																	
Orifice Designation		N		P		Q		R		T		U		V		W	
Orifice Area		in ²	cm ²	in ²	cm ²	in ²	cm ²	in ²	cm ²	in ²	cm ²	in ²	cm ²	in ²	cm ²	in ²	cm ²
		5.047	32.561	7.417	47.852	12.850	82.903	18.600	120.000	30.210	194.903	35.000	225.806	50.260	324.257	78.996	509.651
Set Pressure		Orifice Capacity															
psig	barg	ft ³ /min	m ³ /min	ft ³ /min	m ³ /min	ft ³ /min	m ³ /min	ft ³ /min	m ³ /min	ft ³ /min	m ³ /min	ft ³ /min	m ³ /min	ft ³ /min	m ³ /min	ft ³ /min	m ³ /min
15	1.03	2589	73	3806	107	6594	186	9544	270	15502	438	17960	508	25791	730	40538	1147
20	1.37	2985	84	4388	124	7602	215	11004	311	17873	506	20707	586	29735	842	46736	1323
30	2.06	3778	106	5552	157	9619	272	13923	394	22614	640	26199	741	37623	1065	59133	1674
40	2.75	4649	131	6832	193	11837	335	17134	485	27829	788	32241	912	46299	1311	72770	2060
50	3.44	5520	156	8112	229	14055	397	20345	576	33044	935	38283	1084	54975	1556	86407	2446
60	4.13	6391	180	9393	265	16273	460	23555	667	38259	1083	44325	1255	63651	1802	100044	2832
70	4.82	7263	205	10673	302	18492	523	26766	757	43474	1231	50367	1426	72327	2048	113680	3219
80	5.51	8134	230	11953	338	20710	586	29977	848	48689	1378	56409	1597	81003	2293	127317	3605
90	6.20	9005	254	13234	374	22928	649	33188	939	53904	1526	62451	1768	89680	2539	140954	3991
100	6.89	9876	279	14514	410	25146	712	36399	1030	59119	1674	68493	1939	98356	2785	154591	4377
120	8.27	11619	329	17075	483	29583	837	42820	1212	69549	1969	80577	2281	115708	3276	181864	5149
140	9.65	13361	378	19636	556	34019	963	49242	1394	79979	2264	92660	2623	133061	3767	209138	5922
160	11.03	15104	427	22196	628	38456	1088	55664	1576	90409	2560	104744	2966	150413	4259	236411	6694
180	12.41	16846	477	24757	701	42892	1214	62086	1758	100839	2855	116828	3308	167765	4750	263685	7466
200	13.78	18589	526	27318	773	47329	1340	68507	1939	111269	3150	128912	3650	185118	5241	290958	8239
220	15.16	20331	575	29879	846	51765	1465	74929	2121	121699	3446	140996	3992	202470	5733	318232	9011
240	16.54	22074	625	32439	918	56202	1591	81351	2303	132129	3741	153079	4334	219822	6224	345505	9783
260	17.92	23816	674	35000	991	60638	1717	87772	2485	142559	4036	165163	4676	237175	6716	372779	10555
280	19.30	25559	723	37561	1063	65075	1842	94194	2667	152990	4332	177247	5019	254527	7207	400052	11328
300	20.68	27301	773	40122	1136	69511	1968	100616	2849	163420	4627	189331	5361	271879	7698	427326	12100
320	22.06	29044	822	42682	1208	73948	2093	107037	3030	173850	4922	201415	5703	289232	8190	454599	12872
340	23.44	30786	871	45243	1281	78384	2219	113459	3212	184280	5218	213499	6045	306584	8681	481873	13645
360	24.82	32529	921	47804	1353	82821	2345	119881	3394	194710	5513	225582	6387	323937	9172	509147	14417
380	26.20	34271	970	50364	1426	87257	2470	126302	3576	205140	5808	237666	6729	341289	9664	536420	15189
400	27.57	36014	1019	52925	1498	91694	2596	132724	3758	215570	6104	249750	7072	358641	10155	563694	15962
420	28.95	37756	1069	55486	1571	96130	2722	139146	3940	226000	6399	261834	7414	375994	10646	590967	16734
440	30.33	39498	1118	58047	1643	100567	2847	145567	4121	236430	6694	273918	7756	393346	11138	618241	17506
460	31.71	41241	1167	60607	1716	105003	2973	151989	4303	246860	6990	286001	8098	410698	11629	645514	18278
480	33.09	42983	1217	63168	1788	109440	3098	158411	4485	257290	7285	298085	8440	428051	12121	672788	19051
500	34.47	44726	1266	65729	1861	113876	3224	164832	4667	267720	7580	310169	8783	445403	12612	700061	19823
600	41.36	53438	1513	78533	2223	136058	3852	196941	5576	319870	9057	370588	10493	532165	15069	836429	23685
700	48.26	62151	1759	91336	2586	158241	4480	229049	6485	372021	10534	431007	12204	618927	17526	—	—
800	55.15	70863	2006	104140	2948	180423	5109	261158	7395	424171	12011	491426	13915	—	—	—	—
900	62.05	79576	2253	116944	3311	202606	5737	293266	8304	476321	13487	551845	15626	—	—	—	—
1000	68.94	88288	2500	129747	3674	224788	6365	325375	9213	528472	14964	612265	17337	—	—	—	—
1100	75.84	97001	2746	142551	4036	246971	6993	357483	10122	—	—	—	—	—	—	—	—
1200	82.73	105713	2993	155355	4399	269153	7621	389591	11031	—	—	—	—	—	—	—	—
1300	89.63	114425	3240	168158	4761	291336	8249	421700	11941	—	—	—	—	—	—	—	—
1400	96.52	123138	3486	180962	5124	313518	8877	453808	12850	—	—	—	—	—	—	—	—
1500	103.42	131850	3733	193766	5486	335700	9505	485917	13759	—	—	—	—	—	—	—	—
2000	137.89	175412	4967	257784	7299	—	—	—	—	—	—	—	—	—	—	—	—
2500	172.36	218975	6200	321802	9112	—	—	—	—	—	—	—	—	—	—	—	—
3000	206.84	—	—	—	—	—	—	—	—	—	—	—	—	—	—	—	—
4000	275.79	—	—	—	—	—	—	—	—	—	—	—	—	—	—	—	—
4250	293.02	—	—	—	—	—	—	—	—	—	—	—	—	—	—	—	—
4500	310.26	—	—	—	—	—	—	—	—	—	—	—	—	—	—	—	—
4750	327.50	—	—	—	—	—	—	—	—	—	—	—	—	—	—	—	—
5000	344.73	—	—	—	—	—	—	—	—	—	—	—	—	—	—	—	—
5250	361.97	—	—	—	—	—	—	—	—	—	—	—	—	—	—	—	—
5500	379.21	—	—	—	—	—	—	—	—	—	—	—	—	—	—	—	—
5750	396.44	—	—	—	—	—	—	—	—	—	—	—	—	—	—	—	—
6000	413.68	—	—	—	—	—	—	—	—	—	—	—	—	—	—	—	—
6250	430.92	—	—	—	—	—	—	—	—	—	—	—	—	—	—	—	—

Capacities

Water

Valve Capacity for ASME B&PV Code Section VII, for Water																			
Based at 10% overpressure or 3 psig (0.21 barg), whichever is greater, with zero backpressure. Units of gal/min (L/min) at 70°F (21.1°C), showing 90% average capacity in accordance with latest ASME Code requirements.																			
Orifice Designation		D		E		F		G		H		J		K		L		M	
Orifice Area		in ²	cm ²	in ²	cm ²	in ²	cm ²	in ²	cm ²	in ²	cm ²	in ²	cm ²	in ²	cm ²	in ²	cm ²	in ²	cm ²
		0.128	0.825	0.228	1.470	0.357	2.302	0.585	3.774	0.913	5.888	1.496	9.652	0.913	5.888	1.496	9.652	4.186	27.006
Set Pressure		Orifice Capacity																	
psig	barg	gpm	L/min	gpm	L/min	gpm	L/min	gpm	L/min	gpm	L/min	gpm	L/min	gpm	L/min	gpm	L/min	gpm	L/min
15	1.03	13	49	24	90	38	143	63	238	98	370	161	609	230	870	358	1355	452	1711
20	1.37	15	56	27	102	43	162	71	268	111	420	182	688	261	987	404	1529	511	1934
30	2.06	18	68	33	124	52	196	85	321	133	503	218	825	312	1181	485	1835	612	2316
40	2.75	21	79	38	143	60	227	98	370	154	582	252	953	361	1366	560	2119	706	2672
50	3.44	24	90	43	162	67	253	110	416	172	651	282	1067	403	1525	626	2369	790	2990
60	4.13	26	98	47	177	73	276	120	454	188	711	309	1169	442	1673	686	2596	865	3274
70	4.82	28	105	50	189	79	299	130	492	203	768	334	1264	477	1805	741	2804	935	3539
80	5.51	30	113	54	204	85	321	139	526	217	821	357	1351	510	1930	792	2998	999	3781
90	6.20	32	121	57	215	90	340	148	560	231	874	378	1430	541	2047	840	3179	1060	4012
100	6.89	34	128	60	227	95	359	156	590	243	919	399	1510	570	2157	885	3350	1117	4228
120	8.27	37	140	66	249	104	393	171	647	266	1006	437	1654	625	2365	970	3671	1224	4633
140	9.65	40	151	72	272	112	423	184	696	288	1090	472	1786	675	2555	1047	3963	1322	5004
160	11.03	43	162	76	287	120	454	197	745	308	1165	505	1911	722	2733	1120	4239	1413	5348
180	12.41	45	170	81	306	127	480	209	791	326	1234	535	2025	765	2895	1188	4497	1499	5674
200	13.78	48	181	86	325	134	507	220	832	344	1302	564	2134	807	3054	1252	4739	1580	5980
220	15.16	50	189	90	340	141	533	231	874	361	1366	592	2240	846	3202	1313	4970	1657	6272
240	16.54	52	196	94	355	147	556	241	912	377	1427	618	2339	884	3346	1372	5193	1731	6552
260	17.92	55	208	98	370	153	579	251	950	392	1483	644	2437	920	3482	1428	5405	1802	6821
280	19.30	57	215	101	382	159	601	261	987	407	1540	668	2528	955	3615	1482	5609	1870	7078
300	20.68	59	223	105	397	165	624	270	1022	422	1597	691	2615	988	3739	1534	5806	1935	7324
320	22.06	61	230	108	408	170	643	279	1056	435	1646	714	2702	1021	3864	1584	5996	1999	7567
340	23.44	62	234	112	423	175	662	287	1086	449	1699	736	2786	1052	3982	1633	6181	2061	7801
360	24.82	64	242	115	435	180	681	296	1120	462	1748	757	2865	1083	4099	1680	6359	2120	8025
380	26.20	66	249	118	446	185	700	304	1150	475	1798	778	2945	1112	4209	1726	6533	2178	8244
400	27.57	68	257	121	458	190	719	312	1181	487	1843	798	3020	1141	4319	1771	6703	2235	8460
420	28.95	69	261	124	469	195	738	320	1211	499	1888	818	3096	1169	4425	1815	6870	2290	8668
440	30.33	71	268	127	480	199	753	327	1237	511	1934	837	3168	1197	4531	1857	7029	2344	8873
460	31.71	73	276	130	492	204	772	334	1264	522	1975	856	3240	1224	4633	1899	7188	2397	9073
480	33.09	74	280	133	503	208	787	342	1294	533	2017	875	3312	1250	4731	1940	7343	2448	9266
500	34.47	76	287	136	514	213	806	349	1321	544	2059	893	3380	1276	4830	1980	7495	2499	9459
600	41.36	83	314	149	564	233	882	382	1446	596	2256	978	3702	1398	5292	2169	8210	2737	10360
700	48.26	90	340	161	609	252	953	413	1563	644	2437	1056	3997	1510	5715	2343	8869	2957	11193
800	55.15	96	363	172	651	269	1018	441	1669	689	2608	1129	4273	1614	6109	2505	9482	3161	11965
900	62.05	102	386	182	688	285	1078	468	1771	731	2767	1198	4534	1712	6480	2657	10057	3353	12692
1000	68.94	107	405	192	726	301	1139	493	1866	770	2914	1263	4780	1805	6832	2800	10599	3534	13377
1100	75.84	113	427	201	760	315	1192	517	1957	808	3058	1324	5011	1893	7165	2937	11117	3707	14032
1200	82.73	118	446	210	794	330	1249	541	2047	844	3194	1383	5235	1977	7483	3068	11613	3871	14653
1300	89.63	123	465	219	829	343	1298	563	2131	878	3323	1440	5450	2058	7790	3193	12086	4030	15255
1400	96.52	127	480	227	859	356	1347	584	2210	911	3448	1494	5655	2136	8085	3313	12541	4182	15830
1500	103.42	132	499	235	889	368	1393	604	2286	943	3569	1547	5856	2211	8369	3430	12983	4328	16383
2000	137.89	152	575	272	1029	426	1612	698	2642	1089	4122	1786	6760	2553	9664	3960	14990	4998	18919
2500	172.36	170	643	304	1150	476	1801	780	2952	1218	4610	1997	7559	2854	10803	4428	16761	5588	21152
3000	206.84	187	707	333	1260	521	1972	855	3236	1334	5049	2187	8278	3126	11833	4851	18363	—	—
4000	275.79	215	813	384	1453	602	2278	—	—	—	—	—	—	—	—	—	—	—	—
4250	293.02	222	840	396	1499	621	2350	—	—	—	—	—	—	—	—	—	—	—	—
4500	310.26	229	866	408	1544	639	2418	—	—	—	—	—	—	—	—	—	—	—	—
4750	327.50	235	889	419	1586	656	2483	—	—	—	—	—	—	—	—	—	—	—	—
5000	344.73	241	912	430	1627	673	2547	—	—	—	—	—	—	—	—	—	—	—	—
5250	361.97	247	934	440	1665	690	2611	—	—	—	—	—	—	—	—	—	—	—	—
5500	379.21	253	957	451	1707	706	2672	—	—	—	—	—	—	—	—	—	—	—	—
5750	396.44	258	976	461	1745	722	2733	—	—	—	—	—	—	—	—	—	—	—	—
6000	413.68	264	999	471	1782	737	2789	—	—	—	—	—	—	—	—	—	—	—	—
6250	430.92	269	1018	481	1820	753	2850	—	—	—	—	—	—	—	—	—	—	—	—

Capacities

Water

Valve Capacity for ASME B&PV Code Section VII, for Water																	
Based at 10% overpressure or 3 psig (0.21 barg), whichever is greater, with zero backpressure. Units of gal/min (L/min) at 70°F (21.1°C), showing 90% average capacity in accordance with latest ASME Code requirements.																	
Orifice Designation	N		P		Q		R		T		U		V		W		
	in ²	cm ²	in ²	cm ²	in ²	cm ²	in ²	cm ²	in ²	cm ²	in ²	cm ²	in ²	cm ²	in ²	cm ²	
Orifice Area	5.047	32.561	7.417	47.852	12.850	82.903	18.600	120.000	30.210	194.903	35.000	225.806	50.260	324.257	78.996	509.651	
Set Pressure	Orifice Capacity																
	psig	barg	gpm	L/min	gpm	L/min	gpm	L/min	gpm	L/min	gpm	L/min	gpm	L/min	gpm	L/min	gpm
15	1.03	545	2063	801	3032	1387	5250	2009	7604	3263	12351	3780	14308	5428	20547	8532	32297
20	1.37	616	2331	905	3425	1568	5935	2271	8596	3688	13960	4273	16175	6136	23227	9645	36510
30	2.06	738	2793	1084	4103	1879	7112	2720	10296	4418	16723	5118	19373	7350	27822	11553	43732
40	2.75	852	3225	1252	4739	2170	8214	3141	11889	5101	19309	5910	22371	8487	32126	13340	50497
50	3.44	952	3603	1400	5299	2426	9183	3511	13290	5703	21588	6608	25014	9489	35919	14915	56459
60	4.13	1043	3948	1534	5806	2657	10057	3847	14562	6248	23651	7239	27402	10395	39349	16338	61846
70	4.82	1127	4266	1656	6268	2870	10864	4155	15728	6749	25547	7819	29598	11228	42502	17648	66804
80	5.51	1205	4561	1771	6703	3068	11613	4442	16814	7215	27311	8359	31642	12003	45436	18866	71415
90	6.20	1278	4837	1878	7109	3255	12321	4711	17833	7652	28965	8866	33561	12731	48192	20010	75746
100	6.89	1347	5098	1980	7495	3431	12987	4966	18798	8066	30533	9345	35374	13420	50800	21093	79845
120	8.27	1476	5587	2169	8210	3758	14225	5440	20592	8836	33447	10237	38751	14701	55649	23106	87465
140	9.65	1594	6033	2343	8869	4059	15364	5876	22243	9544	36127	11057	41855	15879	60108	24958	94476
160	11.03	1704	6450	2505	9482	4340	16428	6282	23779	10203	38622	11821	44747	16975	64257	26681	100998
180	12.41	1808	6844	2657	10057	4603	17424	6663	25222	10822	40965	12538	47461	18005	68156	28299	107123
200	13.78	1905	7211	2800	10599	4852	18366	7023	26584	11407	43180	13216	50028	18979	71843	29830	112918
220	15.16	1998	7563	2937	11117	5089	19263	7366	27883	11964	45288	13861	52469	19905	75348	31286	118430
240	16.54	2087	7900	3068	11613	5315	20119	7694	29124	12496	47302	14478	54805	20790	78698	32677	123695
260	17.92	2173	8225	3193	12086	5532	20940	8008	30313	13007	49236	15069	57042	21639	81912	34012	128749
280	19.30	2255	8536	3313	12541	5741	21732	8310	31456	13498	51095	15638	59196	22456	85005	35296	133609
300	20.68	2334	8835	3430	12983	5942	22492	8602	32562	13971	52885	16187	61274	23244	87988	36534	138296
320	22.06	2410	9122	3542	13407	6137	23231	8884	33629	14430	54623	16718	63284	24007	90876	37733	142834
340	23.44	2484	9402	3651	13820	6326	23946	9157	34663	14874	56304	17232	65230	24745	93670	38894	147229
360	24.82	2556	9675	3757	14221	6510	24643	9423	35669	15305	57935	17732	67122	25463	96387	40021	151495
380	26.20	2627	9944	3860	14611	6688	25316	9681	36646	15724	59521	18218	68962	26161	99030	41118	155648
400	27.57	2695	10201	3960	14990	6862	25975	9933	37600	16133	61070	18691	70753	26840	101600	42186	159691
420	28.95	2761	10451	4058	15361	7031	26615	10178	38527	16531	62576	19152	72498	27503	104110	43228	163635
440	30.33	2826	10697	4154	15724	7197	27243	10417	39432	16920	64049	19603	74205	28150	106559	44245	167485
460	31.71	2890	10939	4247	16076	7359	27856	10652	40322	17300	65487	20044	75874	28783	108955	45240	171252
480	33.09	2952	11174	4339	16424	7517	28454	10881	41189	17673	66899	20475	77506	29402	111298	46213	174935
500	34.47	3013	11405	4428	16761	7672	29041	11105	42037	18037	68277	20897	79103	30008	113592	47166	178542
600	41.36	3301	12495	4851	18363	8404	31812	12165	46049	19759	74795	22892	86655	32873	124437	51668	195584
700	48.26	3565	13494	5239	19831	9078	34363	13140	49740	21342	80788	24726	93598	35506	134404	—	—
800	55.15	3811	14426	5601	21202	9704	36733	14047	53173	22815	86364	26433	100059	—	—	—	—
900	62.05	4042	15300	5941	22489	10293	38963	14899	56398	24199	91603	28036	106127	—	—	—	—
1000	68.94	4261	16129	6262	23704	10850	41071	15705	59449	25508	96558	29553	111870	—	—	—	—
1100	75.84	4469	16917	6568	24862	11379	43074	16472	62353	—	—	—	—	—	—	—	—
1200	82.73	4668	17670	6860	25967	11885	44989	17204	65124	—	—	—	—	—	—	—	—
1300	89.63	4858	18389	7140	27027	12371	46829	17907	67785	—	—	—	—	—	—	—	—
1400	96.52	5042	19086	7410	28049	12838	48597	18583	70344	—	—	—	—	—	—	—	—
1500	103.42	5219	19756	7670	29034	13288	50300	19235	72812	—	—	—	—	—	—	—	—
2000	137.89	6026	22810	8856	33523	—	—	—	—	—	—	—	—	—	—	—	—
2500	172.36	6738	25506	9902	37483	—	—	—	—	—	—	—	—	—	—	—	—
3000	206.84	—	—	—	—	—	—	—	—	—	—	—	—	—	—	—	—
4000	275.79	—	—	—	—	—	—	—	—	—	—	—	—	—	—	—	—
4250	293.02	—	—	—	—	—	—	—	—	—	—	—	—	—	—	—	—
4500	310.26	—	—	—	—	—	—	—	—	—	—	—	—	—	—	—	—
4750	327.50	—	—	—	—	—	—	—	—	—	—	—	—	—	—	—	—
5000	344.73	—	—	—	—	—	—	—	—	—	—	—	—	—	—	—	—
5250	361.97	—	—	—	—	—	—	—	—	—	—	—	—	—	—	—	—
5500	379.21	—	—	—	—	—	—	—	—	—	—	—	—	—	—	—	—
5750	396.44	—	—	—	—	—	—	—	—	—	—	—	—	—	—	—	—
6000	413.68	—	—	—	—	—	—	—	—	—	—	—	—	—	—	—	—
6250	430.92	—	—	—	—	—	—	—	—	—	—	—	—	—	—	—	—

Valve Configuration Code

2900 Series Main Valve

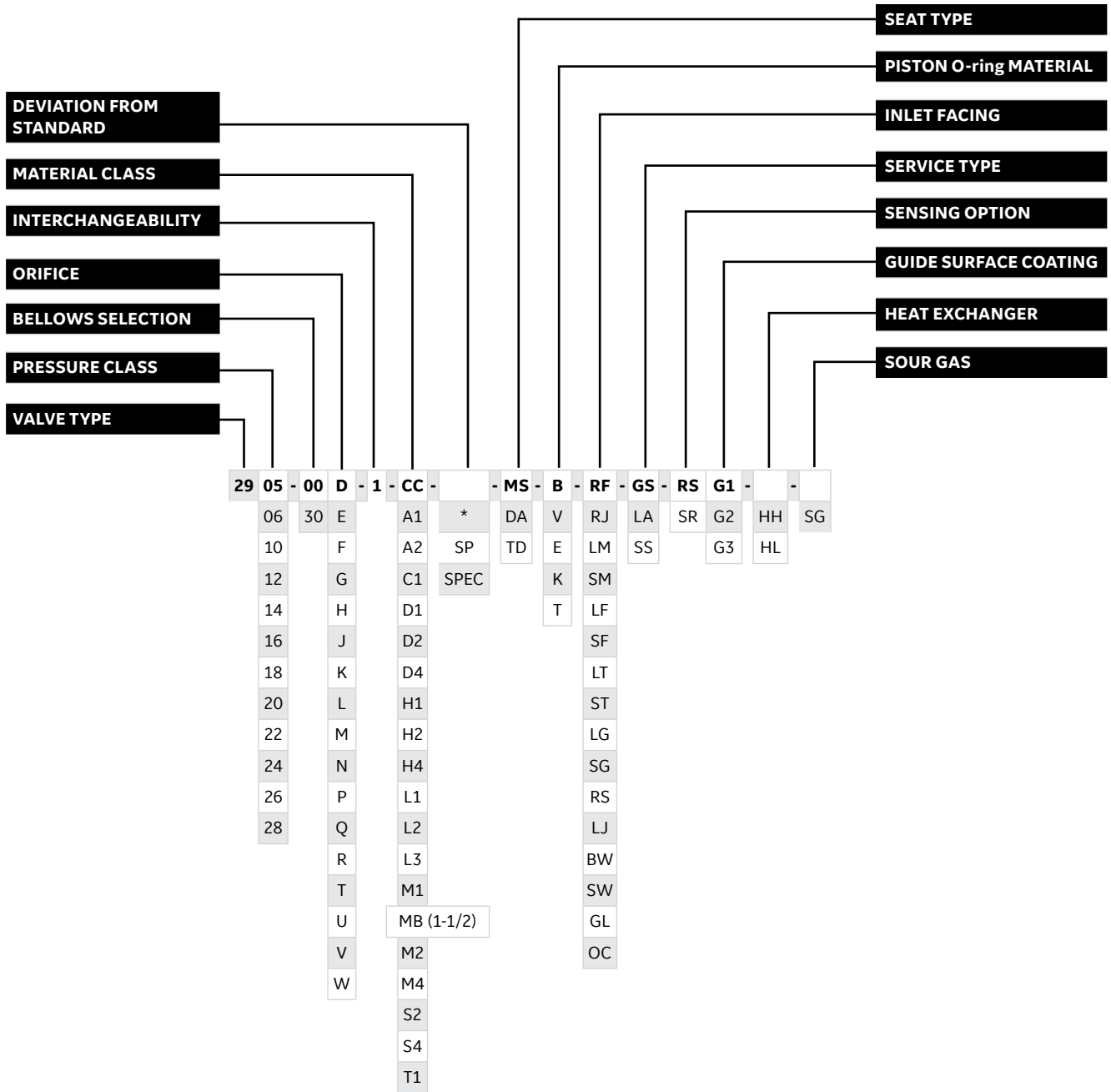

Valve Configuration Code

2900 Series Main Valve

Pressure Class	
Designation	Class
05	150
06	300
10	300
12	600
14	900
16	1500
18	2500
20	300
22	600
23 (P Only)	900
24	900
26	1500
28	2500

Seat Design	
Designation	Type
MS	Metal Seat
DA	O-ring
TD	Thermodisc

Service	
Designation	Type
GS	Gas
LA	Liquid
SS	Steam

Heat Exchanger	
Designation	Type
HH	Media is 506°F (263.3°C) or Above
HL	Media is -41°F (-40.6°C) or Below

Guide Surface Coating	
Designation	Part Coated
G1	Glide-Aloy™ Disc Holder and Piston
G2	Glide-Aloy™ Guide and Coverplate
G3	Glide-Aloy™ Disc Holder, Piston, Guide and Coverplate

Inlet Flange Facing	
Designation	Facing
RF	Raised Face Serrated
RJ	Ring Joint
LM	Large Male
SM	Small Male
LF	Large Female
SF	Small Female
LT	Large Tongue
ST	Small Tongue
LG	Large Groove
SG	Small Groove
RS	Raised Face, Smooth
LJ	Lens Joint
BW	Butt Weld
SW	Socket Weld
GL	Grayloc
OC	Oteco

Standard Orifice Area				
Designation	Area (API)		Area (ASME)	
	in ²	cm ²	in ²	cm ²
D	0.110	2.794	0.128	0.825
E	0.196	4.978	0.228	1.470
F	0.307	7.798	0.357	2.302
G	0.503	12.776	0.585	3.774
H	0.785	19.939	0.913	5.888
J	1.287	32.690	1.496	9.652
K	1.838	46.685	2.138	13.794
L	2.853	72.466	3.317	21.400
M	3.600	91.440	4.186	27.006
N	4.340	110.236	5.047	32.561
P	6.380	162.052	7.417	47.852
Q	11.050	280.670	12.850	82.903
R	16.000	406.400	18.600	120.000
T	26.000	660.400	30.210	194.903
U	N/A	N/A	35.000	225.806
V	N/A	N/A	50.260	324.257
W	N/A	N/A	78.996	509.651

Valve Configuration Code

2900 Series Main Valve

Material Class Variations	
Designation	Variation
CC	Standard Material
A1	Alloy 20 [Nozzle & Disc]
A2	Alloy 20 [Internals]
A4	Alloy 20 [Complete Valve]
C1	Ambient temp. to -50°F (-45.6°C) [LCC construction]
D1	Duplex [Nozzle & Disc]
D2	Duplex [Internals]
D4	Duplex [Complete Valve]
H1	Hastelloy C [Nozzle & Disc]
H2	Hastelloy C [Internals]
H4	Hastelloy C [Complete Valve]
L1	Low Temperature Service [-21°F (-29.4°C) to -75°F (-59.4°C)]
L2	Low Temperature Service [-76°F (-60°C) to -150°F (-101.1°C)]
L3	Low Temperature Service [-151°F (-101.7°C) to -450°F (-267.8°C)]
M1	Monel [Nozzle & Disc]
MB (M1-1/2)	Monel [M1+Disc Holder]
M2	Monel [Internals]
M4	Monel [Complete Valve]
S2	Stainless St. [Internals]
S4	Stainless St. [Complete Valve]
T1	High Temperature Service [1001°F (538.3°C) to 1200°F (648.9°C)]

Sour Gas Applications	
Designation	Type
SG	Non-Bellows

Remote Sensing	
Designation	Type
RS	Remote Sensing
SR	Sensing Ring

Piston O-ring Material	
Designation	Type
B	Burma
V	Viton
E	Ethylene/Propylene
K	Kalrez
T	Teflon

Valve Type	Orifice	Standard Outlet Flange Rating	Actual Body Class Rating	Actual Outlet Flange Class	Mated "M" - Rated "R"	Non Standard Outlet Code*	Additional Tag	Tag Part Number
2905-2912	All	150	150	300	M	15	Yes	7592401
				600		16		
				900		17		
				1500		18		
				2500		19		
2912-2918	D-G	300	300	600	M	16	7592601	
				900		17		
				1500		18		
				2500		19		
2916	H-L							
2918	J-K							
2900	All	150	300	300	R (FULLY RATED)	20	No	N/A
		> 150	600	600		21		
			900	900		22		
			1500	1500		23		
			2500	2500		24		

* The configuration code is modified by adding the "Non-Standard Outlet Code" from this column to the interchangeability number. For example: the interchangeability number is -1 and the Configuration Code from this table is 15 then the interchangeability number is -115.

**See AS043 for installation instructions.

Valve Configuration Code

2900 Series Main Valve

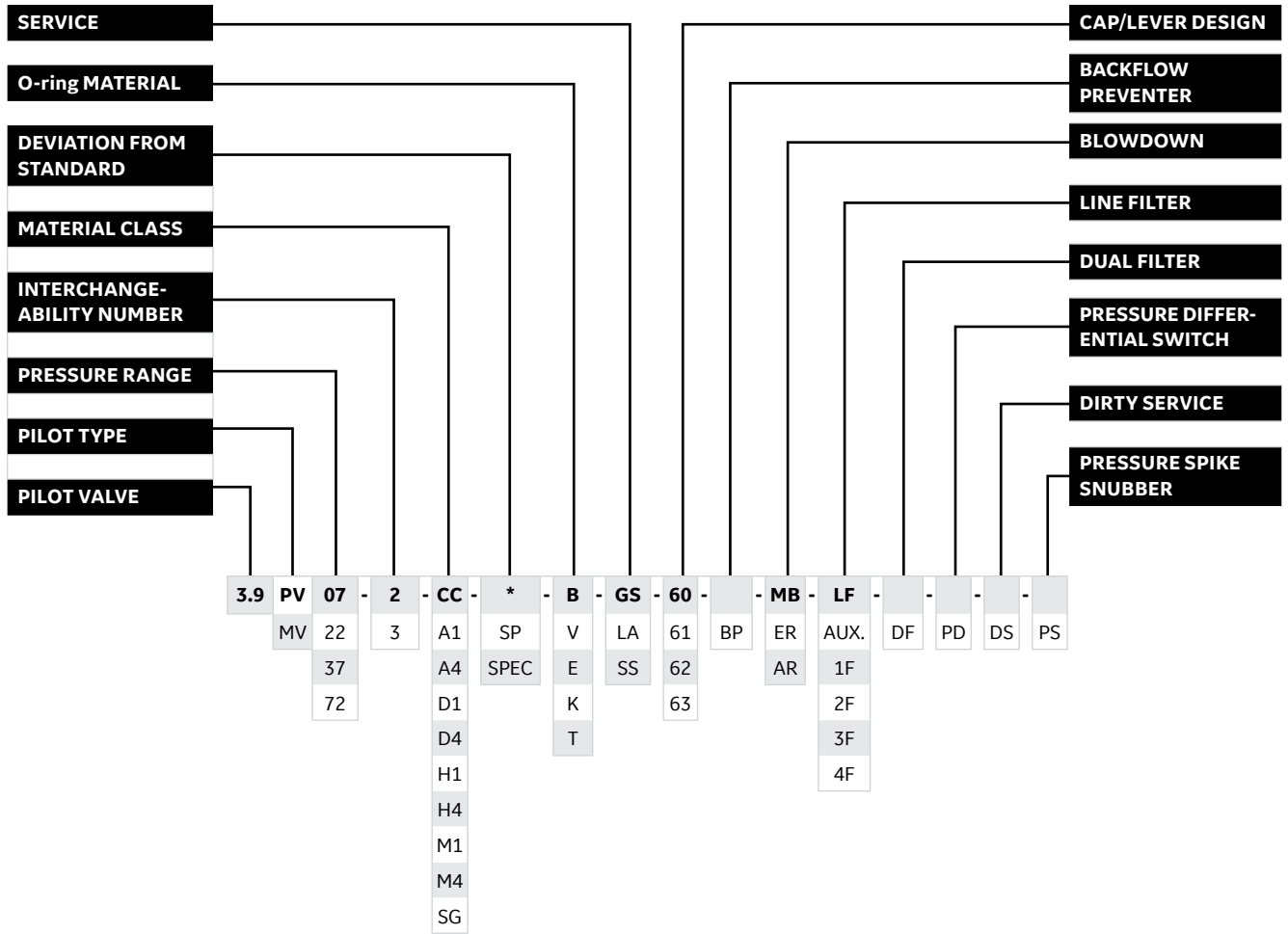

Valve Configuration Code

2900 Series Main Valve

Pilot Type	
Designation	Description
PV	Pop Pilot
MV	Modulating Pilot

Pressure Range	
Designation	Description
07	15 to 750 psig (1.03 - 51.71 barg)
22	751 to 3750 psig (51.78 - 258.55 barg) MV only
37	751 to 3750 psig (51.78 - 258.55 barg) PV only
72	3751 to 6250 psig (258.62 - 430.92 barg) MV only

Interchangeability Number	
Designation	Description
2	Screwed Cap
3	Lifting Lever and/or Gag

Blowdown	
Designation	Description
MB	Manual Blowdown
ER	Electronic Remote
AR	Air Remote

O-ring Material	
Designation	Description
B	Buna (Nitrile)
V	Viton (Fluorocarbon)
E	Ethylene Propylene
K	Kalrez
T	Teflon

Cap / Lever Design	
Designation	Description
60	Screwed Cap (No Gag or Lifting Lever)
61	Gag Only
62	Lifting Lever
63	Gag and Lifting Lever

Sensing Line Filter	
Designation	Description
LF	Line Filter (Standard)
AUX.	High Capacity Filter
1F	Carbon Steel
2F	Stainless Steel
3F	Carbon Steel With Flush Valve
4F	Stainless Steel With Flush Valve

Service	
Designation	Description
GS	Gas
LA	Liquid
SS	Steam

Material Class Variations	
Designation	Description
CC	Standard Material
A1	Alloy 20 [Wetted Parts] (Consult Factory)
A4	Alloy 20 [Complete Valve] (Consult Factory)
D1	Duplex [Wetted Parts] (Consult Factory)
D4	Duplex [Complete Valve] (Consult Factory)
H1	Hastelloy C [Wetted Parts]
H4	Hastelloy C [Complete Valve]
M1	Monel [Wetted Parts]
M4	Monel [Complete Valve]
SG	Sour Gas

Ordering BHGE's 2900 Series MPV Safety Relief Valve

Specification Sheet			
Page_____ of_____		Accessories	
Requisition No.	_____	36.	External Filter: <input type="checkbox"/> YES <input type="checkbox"/> NO
Job No.	_____	37.	Lifting Lever: N/A
Date	_____	38.	Field Test Connection: <input type="checkbox"/> YES <input type="checkbox"/> NO
Revised By	_____	39.	Backflow Preventer: <input type="checkbox"/> YES <input type="checkbox"/> NO
General		40.	Manual Blowdown Valve: <input type="checkbox"/> YES <input type="checkbox"/> NO
1.	Item Number:	41.	Heat Exchange (For High & Low Temperature Applications): <input type="checkbox"/> YES <input type="checkbox"/> NO
2.	Tag Number:	42.	Dirty Service: <input type="checkbox"/> YES <input type="checkbox"/> NO <input type="checkbox"/> OTHER Specify:
3.	Service, Line or Equipment No:	Service Conditions	
4.	Number Required:	43.	Fluid and State:
Basis of Selection		44.	Required Capacity per Valve & Units:
5.	Code: ASME VIII Stamp Required: <input type="checkbox"/> YES <input type="checkbox"/> NO <input type="checkbox"/> Other Specify:	45.	Molecular Weight or Specific Gravity:
6.	Comply with API 526: <input type="checkbox"/> YES <input type="checkbox"/> NO	46.	Viscosity at Flowing Temperature & Units:
7.	<input type="checkbox"/> Fire <input type="checkbox"/> Other Specify:	47.	Operating Pressure & Units:
8.	Rupture Disk: <input type="checkbox"/> YES <input type="checkbox"/> NO	48.	Blowdown: <input type="checkbox"/> Standard <input type="checkbox"/> Other
Valve Design, Pilot		49.	Latent Heat of Vaporization & Units:
9.	Design Type: Pilot	50.	Operating Temperature & Units:
10.	No. of Pilots:	51.	Relieving Temperature & Units:
11.	Pilot Action: <input type="checkbox"/> Pop <input type="checkbox"/> Modulating	52.	Built-up Back Pressure & Units:
12.	Pilot Sense: <input type="checkbox"/> Internal <input type="checkbox"/> Remote ¹	53.	Superimposed Back Pressure & Units:
13.	Seat Type: Resilient	54.	Cold differential Test Pressure & Units:
14.	Seat Tightness: <input type="checkbox"/> API 527 <input type="checkbox"/> Other Specify:	55.	Allowable Overpressure in Percent or Units:
15.	Pilot Vent: <input type="checkbox"/> Atmosphere <input type="checkbox"/> Outlet <input type="checkbox"/> Other Specify:	56.	Compressibility Factor, Z:
Valve Design, Main Base		57.	Ratio of Specific Heats:
16.	<input type="checkbox"/> Metal Seat <input type="checkbox"/> Resilient Seat	Sizing and Selection	
17.	Bellows: <input type="checkbox"/> YES <input type="checkbox"/> NO	58.	Calculated Orifice Area: _____ in ² _____ cm ²
Connections		59.	Selected Orifice Area: _____ in ² _____ cm ²
18.	Inlet Size: _____ Rating: _____ Facing: _____	60.	Orifice Designation (letter): _____
19.	Outlet Size: _____ Rating: _____ Facing: _____	61.	Manufacturer: _____
20.	<input type="checkbox"/> Other Specify: _____	62.	Model Number: _____
Materials, Main Valve		63.	Vendor Calculations Required: <input type="checkbox"/> YES <input type="checkbox"/> NO
21.	Body:	Heat Exchanger	
22.	Nozzle:	64.	Sizing Required:
23.	Seat O-ring:	65.	Back Pressure Restrictions on Temperature:
24.	Disc:	66.	Set Pressure: _____ psig _____ barg
25.	Piston Seal:	67.	Specific Volume of Media at Inlet Conditions: _____ lbm/ft ³ _____ kgm/mtr ³
26.	Other O-rings:	68.	Entropy of Media at Inlet Conditions (btu/lbm*°R): _____
27.	Guide:	69.	Temperature of Ambient Air (°F/°C) (min./max.): _____
28.	Cover Plate:	70.	Media Temperature before it enters the Heat Exchanger: _____ °F _____ °C
Materials, Pilot		Remote Sensing	
29.	Body/Bonnet:	71.	Sizing Required:
30.	Internals:	72.	Set Pressure: _____ psig _____ barg
31.	Seals:	73.	Orifice Selection:
32.	Tubing/Fittings:	74.	Fluid Density of Media in condensed state: _____ lbm/ft ³ _____ kgm/mtr ³
33.	Spring:	75.	Length of Sensing Line ¹ : _____ ft _____ mtr
34.	Comply with NACE MR0175: <input type="checkbox"/> YES <input type="checkbox"/> NO	76.	Equivalent Length of Sensing Line for Valves, Elbows, Tees etc.:
35.	<input type="checkbox"/> OTHER Specify:	77.	Total change in Height: _____ ft _____ mtr

Notes:

1. To assure proper valve operation when pilot is remotely sensed use .375" (9.53 mm) diameter tubing for lengths up to ten feet (3.05 mtr). Contact factory for proper size of tubing when sensing line exceeds ten feet (3.05 mtr).

Notes

Notes

DIRECT SALES OFFICE LOCATIONS

AUSTRALIA

Brisbane:
Phone: +61-7-3001-4319
Fax: +61-7-3001-4399

Perth:
Phone: +61-8-6595-7018
Fax: +61 8 6595-7299

Melbourne:
Phone: +61-3-8807-6002
Fax: +61-3-8807-6577

BELGIUM
Phone: +32-2-344-0970
Fax: +32-2-344-1123

BRAZIL
Phone: +55-19-2104-6900

CHINA
Phone: +86-10-5738-8888
Fax: +86-10-5918-9707

FRANCE
Courbevoie
Phone: +33-1-4904-9000
Fax: +33-1-4904-9010

GERMANY
Ratingen
Phone: +49-2102-108-0
Fax: +49-2102-108-111

INDIA
Mumbai
Phone: +91-22-8354790
Fax: +91-22-8354791

New Delhi
Phone: +91-11-2-6164175
Fax: +91-11-5-1659635

ITALY

Phone: +39-081-7892-111
Fax: +39-081-7892-208

JAPAN

Tokyo
Phone: +81-03-6871-9008
Fax: +81-03-6890-4620

KOREA

Phone: +82-2-2274-0748
Fax: +82-2-2274-0794

MALAYSIA

Phone: +60-3-2161-0322
Fax: +60-3-2163-6312

MEXICO

Phone: +52-55-3640-5060

THE NETHERLANDS

Phone: +31-15-3808666

RUSSIA

Veliky Novgorod
Phone: +7-8162-55-7898
Fax: +7-8162-55-7921

Moscow

Phone: +7 495-585-1276
Fax: +7 495-585-1279

SAUDI ARABIA

Phone: +966-3-341-0278
Fax: +966-3-341-7624

SINGAPORE

Phone: +65-6861-6100
Fax: +65-6861-7172

SOUTH AFRICA

Phone: +27-11-452-1550
Fax: +27-11-452-6542

SOUTH & CENTRAL

AMERICA AND THE CARIBBEAN
Phone: +55-12-2134-1201
Fax: +55-12-2134-1238

SPAIN

Phone: +34-93-652-6430
Fax: +34-93-652-6444

UNITED ARAB EMIRATES

Phone: +971-4-8991-777
Fax: +971-4-8991-778

UNITED KINGDOM

Bracknell
Phone: +44-1344-460-500
Fax: +44-1344-460-537

Skelmersdale

Phone: +44-1695-526-00
Fax: +44-1695-526-01

UNITED STATES

Jacksonville, Florida
Phone: +1-904-570-3409

Corpus Christi, Texas

Phone: +1-361-881-8182
Fax: +1-361-881-8246

Deer Park, Texas

Phone: +1-281-884-1000
Fax: +1-281-884-1010

Houston, Texas

Phone: +1-281-671-1640
Fax: +1-281-671-1735

bhge.com

*Denotes a trademark of Baker Hughes, a GE company, LLC.

Other company names and product names used in this document are the registered trademarks or trademarks of their respective owners.

© 2018 Baker Hughes, a GE company, LLC - All rights reserved.

BHGE reserves the right to make changes in specifications and features shown herein, or discontinue the product described at any time without notice or obligation. Contact your BHGE representative for the most current information. The BHGE logo is a trademark of Baker Hughes, a GE company, LLC. Baker Hughes, a GE company, the GE monogram are trademarks of the General Electric Company and Baker Hughes, a GE company, LLC.

