

Consolidated*

2478 Series

Safety Valve

Maintenance Manual



THESE INSTRUCTIONS PROVIDE THE CUSTOMER/OPERATOR WITH IMPORTANT PROJECT-SPECIFIC REFERENCE INFORMATION IN ADDITION TO THE CUSTOMER/OPERATOR'S NORMAL OPERATION AND MAINTENANCE PROCEDURES. SINCE OPERATION AND MAINTENANCE PHILOSOPHIES VARY, GE (GENERAL ELECTRIC COMPANY AND ITS SUBSIDIARIES AND AFFILIATES) DOES NOT ATTEMPT TO DICTATE SPECIFIC PROCEDURES, BUT TO PROVIDE BASIC LIMITATIONS AND REQUIREMENTS CREATED BY THE TYPE OF EQUIPMENT PROVIDED.

THESE INSTRUCTIONS ASSUME THAT OPERATORS ALREADY HAVE A GENERAL UNDERSTANDING OF THE REQUIREMENTS FOR SAFE OPERATION OF MECHANICAL AND ELECTRICAL EQUIPMENT IN POTENTIALLY HAZARDOUS ENVIRONMENTS. THEREFORE, THESE INSTRUCTIONS SHOULD BE INTERPRETED AND APPLIED IN CONJUNCTION WITH THE SAFETY RULES AND REGULATIONS APPLICABLE AT THE SITE AND THE PARTICULAR REQUIREMENTS FOR OPERATION OF OTHER EQUIPMENT AT THE SITE.

THESE INSTRUCTIONS DO NOT PURPORT TO COVER ALL DETAILS OR VARIATIONS IN EQUIPMENT NOR TO PROVIDE FOR EVERY POSSIBLE CONTINGENCY TO BE MET IN CONNECTION WITH INSTALLATION, OPERATION OR MAINTENANCE. SHOULD FURTHER INFORMATION BE DESIRED OR SHOULD PARTICULAR PROBLEMS ARISE WHICH ARE NOT COVERED SUFFICIENTLY FOR THE CUSTOMER/OPERATOR'S PURPOSES THE MATTER SHOULD BE REFERRED TO GE.

THE RIGHTS, OBLIGATIONS AND LIABILITIES OF GE AND THE CUSTOMER/OPERATOR ARE STRICTLY LIMITED TO THOSE EXPRESSLY PROVIDED IN THE CONTRACT RELATING TO THE SUPPLY OF THE EQUIPMENT. NO ADDITIONAL REPRESENTATIONS OR WARRANTIES BY GE REGARDING THE EQUIPMENT OR ITS USE ARE GIVEN OR IMPLIED BY THE ISSUE OF THESE INSTRUCTIONS.

THESE INSTRUCTIONS ARE FURNISHED TO THE CUSTOMER/OPERATOR SOLELY TO ASSIST IN THE INSTALLATION, TESTING, OPERATION, AND/OR MAINTENANCE OF THE EQUIPMENT DESCRIBED. THIS DOCUMENT SHALL NOT BE REPRODUCED IN WHOLE OR IN PART WITHOUT THE WRITTEN APPROVAL OF GE.

Conversion Table

All the United States Customary System (USCS) values in the Manual are converted to Metric values using the following conversion factors:

USCS Unit	Conversion Factor	Metric Unit
in.	25.4	mm
lb.	0.4535924	kg
in ²	6.4516	cm ²
ft ³ /min	0.02831685	m ³ /min
gal/min	3.785412	L/min
lb/hr	0.4535924	kg/hr
psig	0.06894757	barg
ft lb	1.3558181	Nm
°F	5/9 (°F-32)	°C

Note: Multiply USCS value with Conversion Factor to get Metric value.

NOTICE

For valve configurations not listed in this manual, please contact your local Consolidated Green Tag* Center for assistance.

Table of Contents

I.	Product Safety Sign and Label System	4
II.	Safety Precautions.....	5
III.	Safety Notice	6
IV.	Warranty Information	7
V.	Valve Terminology	7
VI.	Handling and Storage.....	8
VII.	Pre-Installation and Installation Instructions.....	9
VIII.	Introduction	9
IX.	Consolidated 2478 Series Safety Valve.....	10
X.	Operating Principle.....	11
XI.	Disassembly of 2478 Series Safety Valve	11
XII.	Inspection and Part Replacement.....	12
XIII.	Reassembly of 2478 Series Safety Valve	13
XIV.	Setting and Testing.....	14
XV.	Trouble Shooting	14
XVI.	Replacement Parts Planning	15
	A. Basic Guidelines.....	15
	B. Identification and Ordering Essentials	15
XVII.	Genuine Consolidated Parts	15
XVIII.	Recommended Spare Parts	16
XIX.	Manufacturer’s Field Service & Repair Program	17
	A. Field Service.....	17
	B. Factory Repair Facilities.....	17
	C. Safety Valve Maintenance Training.....	17

I. Product Safety Sign and Label System

If and when required, appropriate safety labels have been included in the rectangular margin blocks throughout this manual. Safety labels are vertically oriented rectangles as shown in the *representative examples* (below), consisting of three panels encircled by a narrow border. The panels can contain four messages which communicate:

- The level of hazard seriousness
- The nature of the hazard
- The consequence of human, or product, interaction with the hazard.
- The instructions, if necessary, on how to avoid the hazard.

The top panel of the format contains a signal word (DANGER, WARNING, CAUTION or ATTENTION) which communicates the level of hazard seriousness.

The center panel contains a pictorial which communicates the nature of the hazard, and the possible consequence of human or product interaction with the hazard. In some instances of human hazards the pictorial may, instead, depict what preventive measures to take, such as wearing protective equipment.

The bottom panel may contain an instruction message on how to avoid the hazard. In the case of human hazard, this message may also contain a more precise definition of the hazard, and the consequences of human interaction with the hazard, than can be communicated solely by the pictorial.

①

DANGER — Immediate hazards which **WILL** result in severe personal injury or death.

②

WARNING — Hazards or unsafe practices which **COULD** result in severe personal injury or death.

③

CAUTION — Hazards or unsafe practices which **COULD** result in minor personal injury.

④

ATTENTION — Hazards or unsafe practices which **COULD** result in product or property damage



II. Safety Precautions

⚠ DANGER



Lower pressure and stand clear of discharge when working on valve to avoid severe personal injury or death.

⚠ WARNING



Know all valve exhaust/leakage points to avoid possible severe personal injury or death.

Follow all plant safety regulations, but be sure to observe the following:

- Always lower the working pressure before making any valve adjustment. When making ring adjustments, always gag the valve before making the adjustment. This will avoid possible personal injury.
- Do not stand in front of the discharge side of a safety valve when testing or operating.
- Hearing and eye protection should be used when testing or operating a valve.
- Wear protective clothing. Hot water can burn and superheated steam is not visible.
- When removing the safety valve during disassembly, stand clear and/or wear protective clothing to prevent exposure to splatter, or any corrosive process medium, which may have been trapped inside the valve. Ensure the valve is isolated from system pressure before the valve is removed.
- Exercise care when examining a safety valve for leakage.
- Prior to each actuation, assure that no personnel are near the valve. Steam escaping from the valve during actuation can possibly cause personal injury.
- When popping a safety valve for the first time, or after refurbishment, always be prepared to actuate the valve with the lever while standing in a safe place away from the valve. This may be done by fixing a rope to the lever for actuating the valve from a distance.
- Striking a valve which is under pressure can cause premature actuation. Never tamper with the valve when system pressure is near the valve set pressure.
- Before performing any machining on valve parts, consult GE or its authorized representative. Deviation from critical dimensions can adversely affect valve performance.

III. Safety Notice

Proper installation and start-up is essential to the safe and reliable operation of all valve products. The relevant procedures recommended by GE, and described in these instructions, are effective methods of performing the required tasks.

It is important to note that these instructions contain various “safety messages” which should be carefully read in order to minimize the risk of personal injury, or the possibility that improper procedures will be followed which may damage the involved GE product, or render it unsafe. It is also important to understand that these “safety messages” are not exhaustive. GE can not possibly know, evaluate, and advise any customer of all of the conceivable ways in which tasks might be performed, or of the possible hazardous consequences of each way. Consequently, GE has not undertaken any such broad evaluation and, thus, anyone who uses a procedure and/or tool, which is not recommended by GE, or deviates from GE recommendations, must be thoroughly satisfied that neither personal safety, nor valve safety, will be jeopardized by the method and/or tools selected. Contact your local Green Tag Center or GE at +1 (281) 542-3646 if there are any questions relative to tools/methods.

The installation and start-up of valves and/or valve products may involve proximity to fluids at extremely high pressure and/or temperature. Consequently, every precaution should be taken to prevent injury to personnel during the performance of any procedure. These precautions should consist of, but are not limited to, ear drum protection, eye protection, and the use of protective clothing, (i.e., gloves, etc.) when personnel are in, or around, a valve work area. Due to the various circumstances and conditions in which these operations may be performed on GE products, and the possible hazardous consequences of each way, GE can not possibly evaluate all conditions that might injure personnel or equipment. Nevertheless, GE does offer certain Safety Precautions, listed in Section II, for customer information only.

It is the responsibility of the purchaser or user of GE valves/equipment to adequately train all personnel who will be working with the involved valves/equipment. For more information on training schedules, please contact your local Green Tag Center or the GE Consolidated Training Manager at +1 (281) 542-3646. Further, prior to working with the involved valves/equipment, personnel who are to perform such work should become thoroughly familiar with the contents of these instructions.



IV. Warranty Information

Warranty Statement: GE warrants that its products and work will meet all applicable specifications and other specific product and work requirements (including those of performance), if any, and will be free from defects in material and workmanship. Refer to GE's Standard Terms of Sale, or specific contract for complete details on warranty and limitation of remedy and liability.

Defective and nonconforming items must be held for GE's inspection and returned to the manufacturer upon request.

Incorrect Selection or Misapplication of Products: GE cannot be responsible for customer's incorrect selection or misapplication of our products.

Unauthorized Repair Work: GE has not authorized any non-GE affiliated repair companies, contractors or individuals to perform warranty repair service on new products or field repaired products of its manufacture. Therefore, customers contracting such repair services from unauthorized sources must do so at their own risk.

Unauthorized Removal of Seals: All new valves and valves repaired in the field by GE Field Service are sealed to assure the customer of our guarantee against defective workmanship. Unauthorized removal and/or breakage of this seal will negate our warranty.

V. Valve Terminology

(Paraphrased from ASME's PTC 25)

- **Back Pressure**
Back pressure is the static pressure existing at the outlet of a safety valve device due to pressure in the discharge system.
- **Blowdown**
Blowdown is the difference between actual popping pressure of a safety valve and actual reseating pressure expressed as a percentage of set pressure, or in pressure units.
- **Bore Area**
Bore area is the minimum cross-sectional area of the seat bushing.
- **Bore Diameter**
Bore diameter is the minimum diameter of the seat bushing.
- **Built-Up Back Pressure**
Pressure existing at the outlet of a safety valve while it is open and flowing through a discharge system.
- **Chatter**
Chatter is abnormal, rapid reciprocating motion of the moveable parts of a safety valve, in which the disc contacts the seat.
- **Closing Pressure**
Closing pressure is the value of decreasing inlet static pressure at which the valve disc re-establishes contact with the seat, or at which lift becomes zero.
- **Disc**
A disc is the pressure containing moveable member of a safety valve which affects closure.
- **Inlet Size**
Inlet size is the nominal pipe size of the inlet of a safety valve, unless otherwise designated.
- **Leak Test Pressure**
Leak test pressure is the specified inlet static pressure at which a quantitative seat leakage test is performed in accordance with a standard procedure.
- **Lift**
Lift is the actual travel of the disc away from closed position when a valve is relieving.
- **Lifting Device**
A lifting device is a device for manually opening a safety valve, by the application of external force to lessen the spring loading which holds the valve closed.
- **Seat Bushing**
A seat bushing is the pressure containing element which constitutes the inlet flow passage and includes the fixed portion of the seat closure.
- **Outlet Size**
Outlet size is the nominal pipe size of the outlet passage of a safety valve, unless otherwise designated.
- **Overpressure**
Overpressure is a pressure increase over the set pressure of a safety valve, usually expressed as a percentage of set pressure.

V. Valve Terminology (Contd.)

- **Popping Pressure**

Popping pressure is the value of increasing inlet static pressure at which the disc moves in the opening direction at a faster rate as compared with corresponding movement at higher or lower pressures. It applies only to safety or safety relief valves on compressible fluid service.

- **Pressure Containing Member**

A pressure containing member of a safety valve is a part which is in actual contact with the pressure media in the protected vessel.

- **Pressure Retaining Member**

A pressure retaining member of a safety valve is a part which is stressed due to its function in holding one or more pressure containing members in position.

- **Rated Lift**

Rated lift is the design lift at which a valve attains its rated relieving capacity.

- **Safety Valve**

A safety valve is a pressure relief valve actuated by inlet static pressure and characterized by rapid opening or pop action.

- **Set Pressure**

Set pressure is the value of increasing inlet static pressure at which a safety valve displays the operational characteristics as defined under "Popping Pressure." It is one value of pressure stamped on the safety valve.

- **Seat**

A seat is the pressure containing contact between the fixed and moving portions of the pressure containing elements of a valve.

- **Seat Diameter**

Seat diameter is the smallest diameter of contact between the fixed and moving members of the pressure containing elements of a valve.

- **Seat Tightness Pressure**

Seat tightness pressure is the specific inlet static pressure at which a quantitative seat leakage test is performed in accordance with a standard procedure.

- **Simmer**

Simmer is the audible or visible escape of fluid between the seat and disc at an inlet static pressure below the popping pressure and at no measurable capacity. It applies to safety valves on compressible fluid service.

- **Warn**

See "Simmer" (definition above).

VI. Handling and Storage

1. The valves should be stored in a dry environment to protect them from the weather.
2. The valves should never be subjected to sharp impact. This would be most likely to occur by bumping or dropping during loading or unloading from a truck or while moving with a power conveyor, such as a fork lift truck.
3. Meticulous care should be exercised to prevent dirt and other foreign materials from entering the inlet and outlet ports during storage as well as in installation.

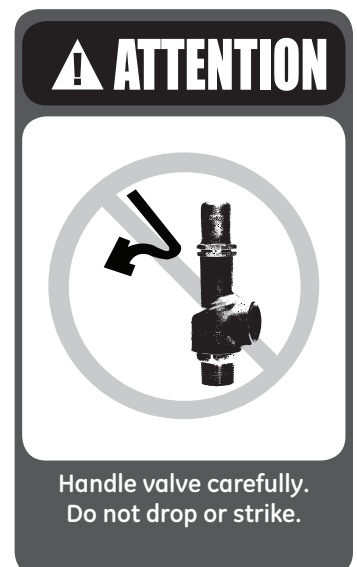

VII. Pre-Installation & Installation Instructions

The 2478 Series safety valve is provided with a male NPT inlet connection and a standard hexagon surface for easy wrench installation. Exhaust outlets are female NPT connections suitable for standard size pipe fittings. The 2478 Series relief valve must be connected in an upright vertical position on equal size fittings. Furthermore, in no case should the discharge pipe connected to the valve be of a smaller size than the valve outlet. No stop valve or other obstruction should be placed between the equipment and the relief valve.

Thoroughly clean the inlet of the valve before installation and be sure that no pipe thread compound gets into the bore of the valve during installation.

During installation do not use excessive wrenching force that may distort the hex on the valve base. The valve must not be tightened by means of a pipe screwed into the outlet. The valve at all times should be free from the discharge piping. The riser pipe should be large enough to accommodate the full capacity of the valve without causing a back pressure build up on the valve.

VIII. Introduction

A relief valve is a key safety device that protects against catastrophic pressure vessel failure. However, if it is not properly installed, maintained, operated and repaired, the pressure vessel is like a potential bomb.

For example: A 30-gallon (114 Ltr.) hot water tank at 90 psig (6.21 barg) has 3,138,400 ft-lb (4,25,5099 N-m) of energy to flash its water into steam at 330°F (166°C) if liberated by rupture. Energy of a pound of three common explosives is:

Black powder	906 ft-lb (1228 N-m)
Smokeless powder	1260 ft-lb (1708 N-m)
Nitroglycerin	2,000,000 ft-lb (2,711,636 N-m)

On this basis, the 30-gallon (114 Ltr.) tank is equivalent to about 1.5 lb (0.68 kg) of nitroglycerin. Catastrophes, of course, are not the only loss exposure from improper safety-valve operation. Overpressure can rupture tubing and blow out packing. Improperly maintained safety valves, at times, may relieve at too low a pressure or may leak, so the boiler never reaches the desired pressure or full efficiency. The result of these problems is unscheduled downtime. In summary, proper installation, maintenance and repair is as important as buying of a reliable valve. This manual therefore provides instructions for installation, maintenance and repair of Consolidated Bronze Safety Valves.

IX. Consolidated 2478 Series Safety Valves

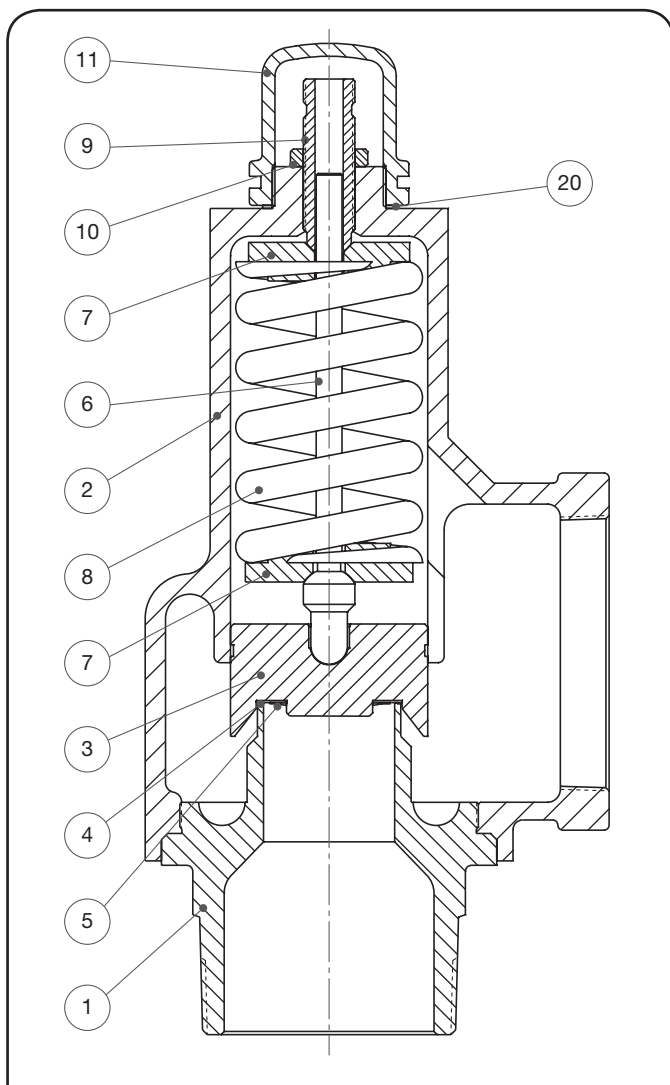

Figure 1: 2478 Standard Soft Seat Design

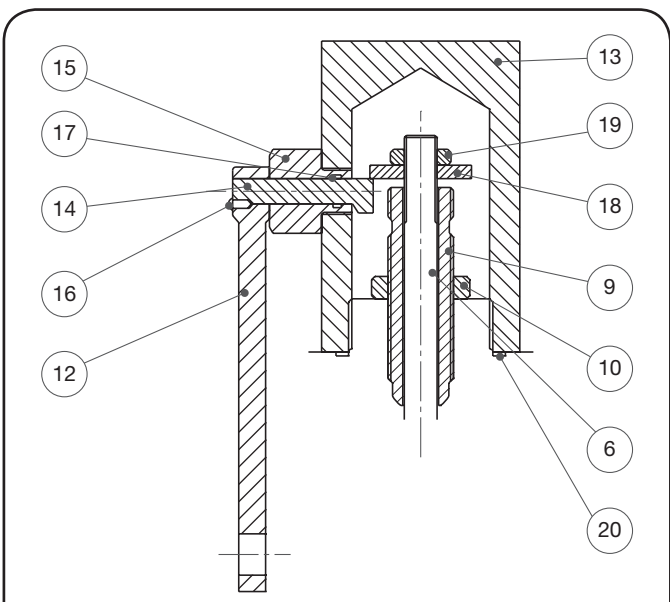

Figure 2: Packed Cap Assembly

Ref No.	Nomenclature
1	Base
2	Bonnet
3	Disc
4	Seat Washer
5	Soft Seat Retainer Ring
6	Spindle
7	Spring Washer
8	Spring
9	Compression Screw
10	Compression Screw Locknut
11	Screwed Cap
12	Lever
13	Packed Cap
14	Cam Shaft
15	Bushing
16	Drive Screw
17	O-Ring
18	Release Nut
19	Release Locknut
20	O-Ring Gasket

X. Operating Principle

During system operating conditions, the spring force applied due to compression screw is higher than the upward acting pressure force on the disc. As a result, the valve is in the closed position. When system pressure reaches the opening pressure of the valve, the upward acting pressure force equals the downward acting spring force, hence valve begins to open. If system pressure increases more than the opening pressure, the valve opens

proportionately. There is no pop type action on the liquid valve due to an absence of expansion characteristics in liquid (incompressible fluid). The valve lift will depend upon the degree of overpressure. During the lifting action, the disc is guided in precisely machine bonnet guiding surface. The valve closes, once system pressure reaches closing pressure of the valve.

XI. Disassembly of 2478 Series Safety Valve

1. Remove Screwed Cap or Packed Cap-Lever assembly.
2. Remove Release Nut and Release Locknuts in valves with cap-lever assembly.
3. Release Compression Screw Locknut and release spring compression by turning Compression Screw counter-clockwise.
4. With valve Base held in vise loosen Bonnet to Base connection (use strap wrench, do not use pipe wrench as this may crush the bonnet).
5. Holding Bonnet upside down, unscrew and remove Base.
6. With one hand on Disc, rotate valve over and remove Disc, Spindle, Spring and Spring Washer Assembly from Bonnet.
7. Remove Disc by pulling the Spindle out of Disc pocket.
8. If Soft Seat is damaged as shown by nicks, cuts and dents, remove Retainer Ring by a sharp tool. Subsequently, remove Soft Seat using the same tool. These two parts must not be used again.



XII. Inspection and Part Replacement

The valve repair operation will depend upon the damage. In some cases, it is easier to replace the part. In a number of cases, only the nozzle and disc need to be repaired. This can be done in the following manner:

1. If the disc is damaged by nicks, cuts, dents on the soft seat, it is to be replaced by using any sharp tool to pull out the retaining ring, then soft seat. See Reassembly Procedure for installing new soft seat.
2. Lapping a flat seat is extremely simple. No special skill is required and the technique is readily apparent after a few minutes of actual lapping.
3. The following precautions and hints will enable anyone to do a "Professional" job of lapping seats.
 - a. Keep the work clean.
 - b. Always use a fresh lap. If signs of wearing (out of flatness) are evident, recondition the lap.
 - c. Apply a very thin layer of compound to the lap. This will prevent rounding off the edges of the seat.
 - d. Keep the lap squarely on the flat surface and avoid any tendency to rock the lap which will cause rounding of the seat.
 - e. When lapping the Base keep a firm grip on the lap or part to prevent the possibility of dropping it and damaging the seat.
- f. Lap, using a reciprocating motion in all directions, at the same time applying uniform pressure and rotating the lap or the part slowly. If reconditioning necessitates removing more than .010" (0.03 mm), replace the base.
- g. Replace the compound frequently after wiping off the old compound, and apply more pressure to speed the cutting action of the compound.
- h. To check the seating surfaces, remove all compound from the lap. Then, shine up the seat with the same lap using the lapping motion described above. Low sections on the seating surface will show up as a shadow in contrast to the shiny portion. If shadows are present, further lapping is necessary, and only laps known to be flat should now be used. Only a few minutes will be required to remove the shadows.
- i. When the lapping is completed, any lines appearing as cross scratches can be removed by rotating the lap which has been wiped clean of compound on the seat about its own axis.
- j. The seat should now be thoroughly cleaned with kerosene, light oil, or carbon tetrachloride, using a lint-free cloth or tissue paper.

XIII. Reassembly of 2478 Series Safety Valve

1. Clean seats and all parts
2. Disc Assembly:
 - a. Clean disc and place it on a level metallic plate as shown in Figure 3. Disc surface having the spindle pocket will lie on the metal plate.
 - b. Pick-up proper soft seat; clean this with lint free cloth. Inspect it for nicks, cuts, dents (defective soft seat should be rejected). Place soft seat onto the disc as shown in Figure 3.
 - c. Pick-up proper retaining ring and tool assembly (see Table 1). Place retaining ring on the disc post (see Figure 3). Subsequently put the retaining ring tool assembly in a mechanical press (not shown in Figure 3). By applying slight force, position retaining ring over the disc post. Inspect the ring to ensure its proper positioning. Subsequently, press the ring hard enough to move it down to provide tight

retaining of the soft seat. A properly assembled soft seat will be somewhat compressed by the retaining ring.

3. Place spindle into disc pocket.
4. Insert disc, spindle, spring and spring washer assembly into bonnet.
5. Holding bonnet upside down (so that disc will not drop), install the base to the bonnet assembly. Tighten bonnet on base using torque values:
 D: 50 ft-lb (68 N-m), E: 60 ft-lb (81 N-m),
 F: 65 ft-lb (88 N-m), G: 75 ft-lb (102 N-m),
 H: 90 ft-lb (122 N-m), J: 100 ft-lb (136 N-m).
6. Assemble compression screw and provide spring compression by two turns of compression screw. The desired spring compression must be established.

Table 1: 2478 Bronze Safety Valve Soft Seat Assembly Tools		
Valve Type	Retaining Ring	Assembly Tool No.
2478D	2091155	7530163-1
2478E	2091156	7530163-3
2478F	2091157	7530163-5
2478G	2091158	7530163-7
2478H	2091160	7530163-9
2478J	2091162	7530163-11

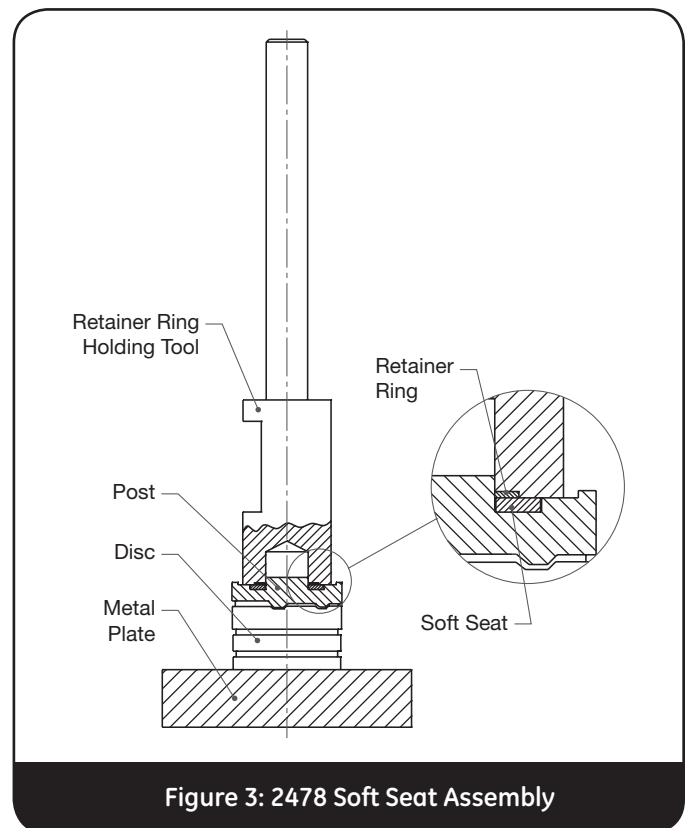

XIV. Setting and Testing

To change opening pressure of the valve, loosen the locknut. Turn the compression screw clockwise to increase pressure or counter-clockwise to decrease pressure. The opening pressure of the valve is indicated by the first continuous discharge of the liquid through outlet. Before opening, in a

number of cases, liquid will discharge one drop at a time. This is not to be confused with valve opening pressure. This should happen beyond the leak tightness pressure of the valve and before its opening pressure.

XV. Trouble Shooting

Certain troubles may develop through use or damage to working parts. The most common are leakage, chattering, hang-up, and set pressure variation.

Leakage is the constant escape of liquid at normal operating pressure below the leak tightness pressure of the valve. It is caused by either damage to the seating surfaces or to foreign matter being trapped. If during pressure testing or manual lifting, wide open does not give relief, the valve should be repaired at the first opportunity to prevent further damage. Another cause of leakage is a bent spindle that causes hang-up and improper installation of discharge piping so as to introduce undue strain upon the valve.

Chattering is a hammering action of a vibratory nature of the disc on the nozzle seat and must be stopped immediately to protect the seating surface. Chattering is caused by excessive back pressure from undersized discharge piping, insufficient flow compared to the rated flow and an undersized or closed vent hole in the bonnet outlet.

Hang-up occurs upon closing and is defined as leakage from the valve failing to shut-off tightly. Mechanical interference is the primary cause. Disc and disc guiding area in the bonnet should be examined.

Set pressure variation may be caused by spring relaxation, damage to the seats from foreign matter, from chatter or difference in thermal conditions between various test runs.

The drop off in opening pressure due to spring relaxation may be caused by excessive valve lift in the event of excessive discharge beyond rated flow. The compression screw can be adjusted to provide desired set pressure. However, this should be done for temporary relief. The relaxed spring should be replaced with a new one. Between initial and subsequent test runs, the soft seat settles a little bit providing a drop off in opening pressure. However, three consecutive test runs within opening pressure tolerance should indicate settling of the soft seat. Any drop in opening pressure can be corrected by turning compression screw clockwise and by verifying the opening pressure by test.

XVI. Replacement Parts Planning

A. Basic Guidelines

The basic objectives in formulating a replacement parts plan are:

- PROMPT AVAILABILITY
- MINIMUM DOWNTIME
- SENSIBLE COST
- SOURCE CONTROL

Consult the Recommended Spare Parts list (see Section XVIII of this manual) to define the parts to be included in the inventory plan.

Select parts and specify quantities.

B. Identification and Ordering Essentials

When ordering service parts, please furnish the following information to ensure receiving the correct replacement parts:

Specify parts required by:

1. Part Name (See Figures 1 to 2).
2. Part Number (if known)
3. Quantity

Contact your local Green Tag Center.

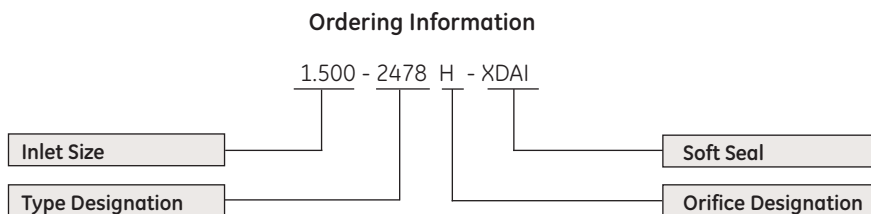

XVII. Genuine Consolidated Parts

The next time replacement parts are needed, keep these points in mind:

- GE designed the parts
- GE guarantees the parts
- Consolidated valve products have been in use since 1879
- GE has worldwide service
- GE has fast response availability for parts with the global Green Tag Center / Authorized Sales Representatives network.

XVIII. Recommended Spare Parts

The recommended spare parts/tools are spring, disc, soft seat, retaining ring and retaining ring assembly tools. When ordering replacement or spare parts, state type, size, and set pressure of the valve, and fluid type.

Refer to Consolidated 2478 Series Safety Valve catalogue for more detailed information on parts descriptions and nomenclatures.

Table 3: Component: Soft Seat Disc						
Valve Type	4266601	4266701	4266801	4266901	4267001	4267101
2478D	X					
2478E		X				
2478F			X			
2478G				X		
2478H					X	
2478J						X

Table 4: Component: Retainer Ring						
Valve Type	2091155	2091156	2091157	2091158	2091160	2091162
2478D	X					
2478E		X				
2478F			X			
2478G				X		
2478H					X	
2478J						X

Table 5: Component: Spring Washers (2)						
Valve Type	VBG906B	VBA906	VAV906	VBH906	VAU906	4342601
2478D	X					
2478E		X				
2478F			X			
2478G				X		
2478H					X	
2478J						X

XIX. Manufacturer's Field Service & Repair Program

A. Field Service

Utilities and Process Industries expect and demand service at a moment's notice. GE's Field Service can be depended upon for prompt response, even in extreme off-hour emergency situations.

GE maintains the largest and most competent field service staff in the industry. Service Engineers are located at strategic points throughout the United States to respond to customer's requirements for service. Each Service Engineer is factory trained and long experienced in servicing safety valves. GE's Service Engineers restore disc and seat bushing critical dimensions which affect valve performance, and are capable of modernizing valves in the field.

It is highly recommended that the professional talents of a GE Field Service Engineer be employed to make final field adjustments during the initial setting of all Consolidated Safety Valves.

B. Factory Repair Facilities

GE's Consolidated factory maintains a Repair Center. The repair department, in conjunction with the manufacturing facilities, is equipped to perform specialized repairs and product modifications, e.g., bushing replacements, hydroset calibrations, electromatic relief valve repairs, etc.

C. Safety Valve Maintenance Training

Rising costs of maintenance and repair in the Utility and Process Industries indicate the need for trained maintenance personnel. GE conducts service seminars that can help your maintenance and engineering personnel to reduce these costs.

Seminars, conducted either at your site, or at our manufacturing plant, provide participants with an introduction to the basics of preventative maintenance. These seminars help to minimize downtime, reduce unplanned repairs and increase valve safety. While they do not make "instant" experts, they do provide the participants with "Hands On" experience with Consolidated valves. The seminar also includes valve terminology and nomenclature, component inspection, trouble shooting, setting and testing, with emphasis on the ASME Boiler and Pressure Vessel Code.

For further information, please contact your local Green Tag Center or GE's Consolidated Training Manager at +1 (281) 542-3646.

DIRECT SALES OFFICE LOCATIONS

AUSTRALIA

Brisbane
Phone: +61-7-3001-4319
Fax: +61-7-3001-4399

Perth
Phone: +61-8-6595-7018
Fax: +61-8-6595-7299

Melbourne
Phone: +61-3-8807-6002
Fax: +61-3-8807-6577

BELGIUM
Phone: +32-2-344-0970
Fax: +32-2-344-1123

BRAZIL
Phone: +55-19-2104-6900

CHINA
Phone: +86-10-5689-3600
Fax: +86-10-5689-3800

FRANCE
Courbevoie
Phone: +33-1-4904-9000
Fax: +33-1-4904-9010

GERMANY
Ratingen
Phone: +49-2102-108-0
Fax: +49-2102-108-111

INDIA
Mumbai
Phone: +91-22-8354790
Fax: +91-22-8354791

New Delhi
Phone: +91-11-2-6164175
Fax: +91-11-5-1659635

ITALY

Phone: +39-081-7892-111
Fax: +39-081-7892-208

JAPAN
Tokyo
Phone: +81-03-6871-9008
Fax: +81-03-6890-4620

KOREA
Phone: +82-2-2274-0748
Fax: +82-2-2274-0794

MALAYSIA
Phone: +60-3-2161-0322
Fax: +60-3-2163-6312

MEXICO
Phone: +52-55-3640-5060

THE NETHERLANDS
Phone: +31-15-3808666
Fax: +31-18-1641438

RUSSIA
Veliky Novgorod
Phone: +7-8162-55-7898
Fax: +7-8162-55-7921

Moscow
Phone: +7 495-585-1276
Fax: +7 495-585-1279

SAUDI ARABIA
Phone: +966-3-341-0278
Fax: +966-3-341-7624

SINGAPORE
Phone: +65-6861-6100
Fax: +65-6861-7172

SOUTH AFRICA

Phone: +27-11-452-1550
Fax: +27-11-452-6542

SOUTH & CENTRAL
AMERICA AND THE CARIBBEAN
Phone: +55-12-2134-1201
Fax: +55-12-2134-1238

SPAIN
Phone: +34-93-652-6430
Fax: +34-93-652-6444

UNITED ARAB EMIRATES
Phone: +971-4-8991-777
Fax: +971-4-8991-778

UNITED KINGDOM
Bracknell
Phone: +44-1344-460-500
Fax: +44-1344-460-537

Skelmersdale
Phone: +44-1695-526-00
Fax: +44-1695-526-01

UNITED STATES
Massachusetts
Phone: +1-508-586-4600
Fax: +1-508-427-8971

Corpus Christi, Texas
Phone: +1-361-881-8182
Fax: +1-361-881-8246

Deer Park, Texas
Phone: +1-281-884-1000
Fax: +1-281-884-1010

Houston, Texas
Phone: +1-281-671-1640
Fax: +1-281-671-1735

www.geoilandgas.com/valves

*Denotes a trademark of the General Electric Company.

© 2016 General Electric Company. All rights reserved.

Other company names and product names used in this document are the registered trademarks or trademarks of their respective owners.

