

Consolidated* 2478 Series Safety Valve

The 2478 series pressure relief valve has a totally enclosed design for non-corrosive, thermal-relief, liquid service.



Table of Contents

Features and Benefits	2
Specifications	2
Applications.....	2
Connections.....	2
Options	2
Conversion Table.....	3
Scope of Design	4
Materials	5
Dimensions and Weights.....	6
Orifice Capacities	7
Valve Configuration Code	8
Ordering a 2478 Safety Valve.....	9

Features and Benefits

- Low spindle bearing point between the spindle and disc for improved tightness
- Self-aligning spring washers for repeatability and long life
- Totally enclosed bonnet to ensure that escaping fluid is properly discharged
- Precision-wound spring plus 5 percent tolerance on rate to ensure repeatability and maximum tightness
- Manufactured to ASME Code standards
- Tested for set pressure on water

Specifications

INLET SIZES	.500 in. (12.70 mm) through 2.500 in. (63.50 mm) threaded.
OUTLET SIZES	.750 in. (19.05 mm) through 2.500 in. (63.50 mm) threaded
ORIFICE SIZES	Six sizes: D through J
PRESSURE RANGE	5 psig (0.34 barg) to 300 psig (20.68 barg)
TEMPERATURE RANGE	-325°F (-198.3°C) to 406°F (207.8°C)
MATERIALS	Cast bronze bonnet, brass base and trim and PTFE soft seats are standard.
CERTIFICATION	Non-coded
BLOWDOWN	7 - 15 percent
BACK PRESSURE LIMIT	10 percent of set pressure

Applications

Design limits of 300 psig (20.68 barg) and -325°F (-198°C) to +406°F (+207°C). This product should only be used for non-corrosive liquids. GE's Consolidated 2478 Series Safety Valve is not ASME Code capacity-certified. Cryogenic service applications can be satisfied by consulting the factory.

Connections

The 2478 Series Safety Valve is supplied with .500 in. (12.70 mm) through 2.500 in. (63.50 mm) male NPT inlet sizes. The inlet is equipped with a standard hexagon surface for easy wrenching.

Options

- Sealed Lifting Lever Assembly
- Spring 17-7 PH SS is available

GE provides a full range of Consolidated pressure relief valve styles, sizes, options and configurations for multiple industries, applications, environments, and media. From spring-actuated to pilot-operated, each pressure relief valve is configured to offer safer process flow control in harsh environments.

Conversion Table

All the USCS values are converted to metric values using the following conversion factors:

USCS Unit	Conversion Factor	Metric Unit
in.	25.4	mm
lb.	0.4535924	kg
in ²	6.4516	cm ²
ft ³ /min	0.02831685	m ³ /min
gal/min	3.785412	L/min
lb/hr	0.4535924	kg/hr
psig	0.06894757	barg
ft lb	1.3558181	Nm
°F	5/9 (°F-32)	°C

Scope of Design

Standard Inlet/Outlet Connections						
Orifice Designation	Discharge Area		Inlet Size, Male NPT		Outlet Size, Female NPT	
	in ²	cm ²	in.	mm	in.	mm
D	0.110	0.710	.50	12.7	.75	19.1
D	0.110	0.710	.75	19.1	.75	19.1
E	0.196	1.265	1.00	25.4	1.00	25.4
F	0.307	1.981	1.25	31.8	1.25	31.8
G	0.503	3.245	1.50	38.1	1.50	38.1
H	0.785	5.065	2.00	50.8	2.00	50.8
J	1.287	8.303	2.50	63.5	2.50	63.5

Pressure/Temperature Limits					
Valve Type	Orifice	Temperature Range		Maximum Set Pressure	
		°F	°C	psig	barg
2478	All	-325 to +406	-198 to +207	300	20.68

Materials

2478 Series Safety Valve

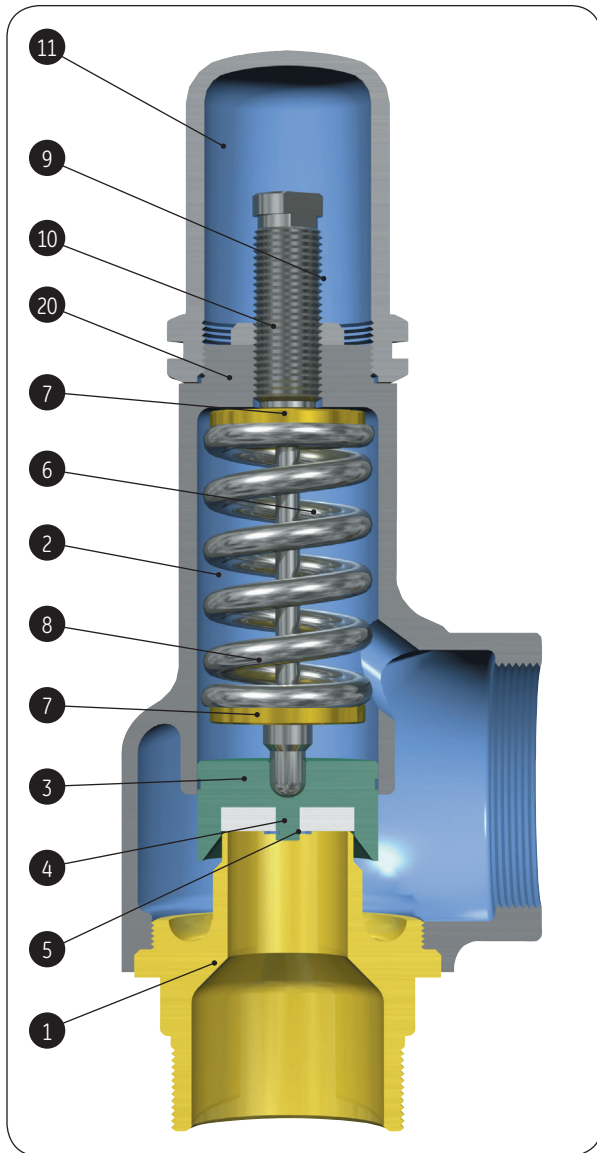

Sealed Lifting Lever Assembly

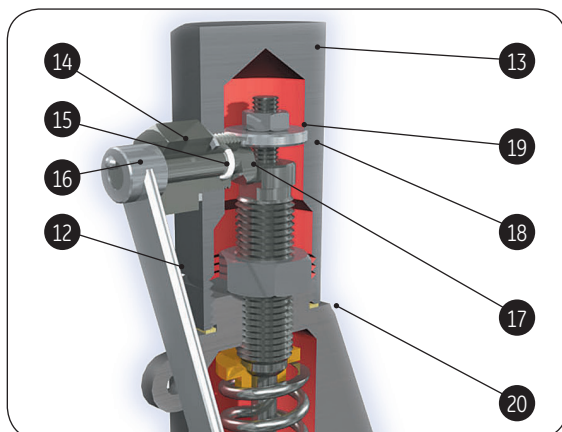

Part and Material		
Part No.	Part Name	Material
1	Base	ASTM B283 Alloy C46400 Naval Brass
2	Bonnet	ASTM B584 Alloy C84400 Bronze
3	Disc	ASTM B124 Alloy C46400 Half Hard Brass
4	Seat Washer	Teflon
5	Soft Seat Retainer Ring	PH15-7 Mo Stainless Steel
6	Spindle	ASTM B124 Alloy C46400 Half Hard Brass
7	Spring Washer	ASTM B16 Half Hard Brass
8	Spring	Alloy Steel (Aluminum Metallized) ¹
9	Compression Screw	ASTM B16 Half Hard Brass
10	Compression Screw Locknut	ASTM B16 Half Hard Brass
11	Screwed Cap	ASTM B584 Alloy C84400 Bronze
12	Lever	ASTM A47 Grade 35018 Malleable Iron
13	Packed Cap	ASTM B16 Half Hard Brass
14	Cam Shaft	ASTM A276 Type 410, Cond. T SSt.
15	Bushing	ASTM A582 Type 416, Cond. A SSt.
16	Drive Screw	Steel (Nickel Plated)
17	O-Ring	Buna N (Durometer 70)
18	Release Nut	ASTM A276 Type 410, Cond. T SSt.
19	Release Locknut	Carbon Steel
20	O-Ring Gasket	Viton

Note:

1. Spring to be Stainless Steel for temperatures of -30 to -325°F (-34.4 to -198.3°C)

Dimensions and Weights

2478 Series Safety Valve

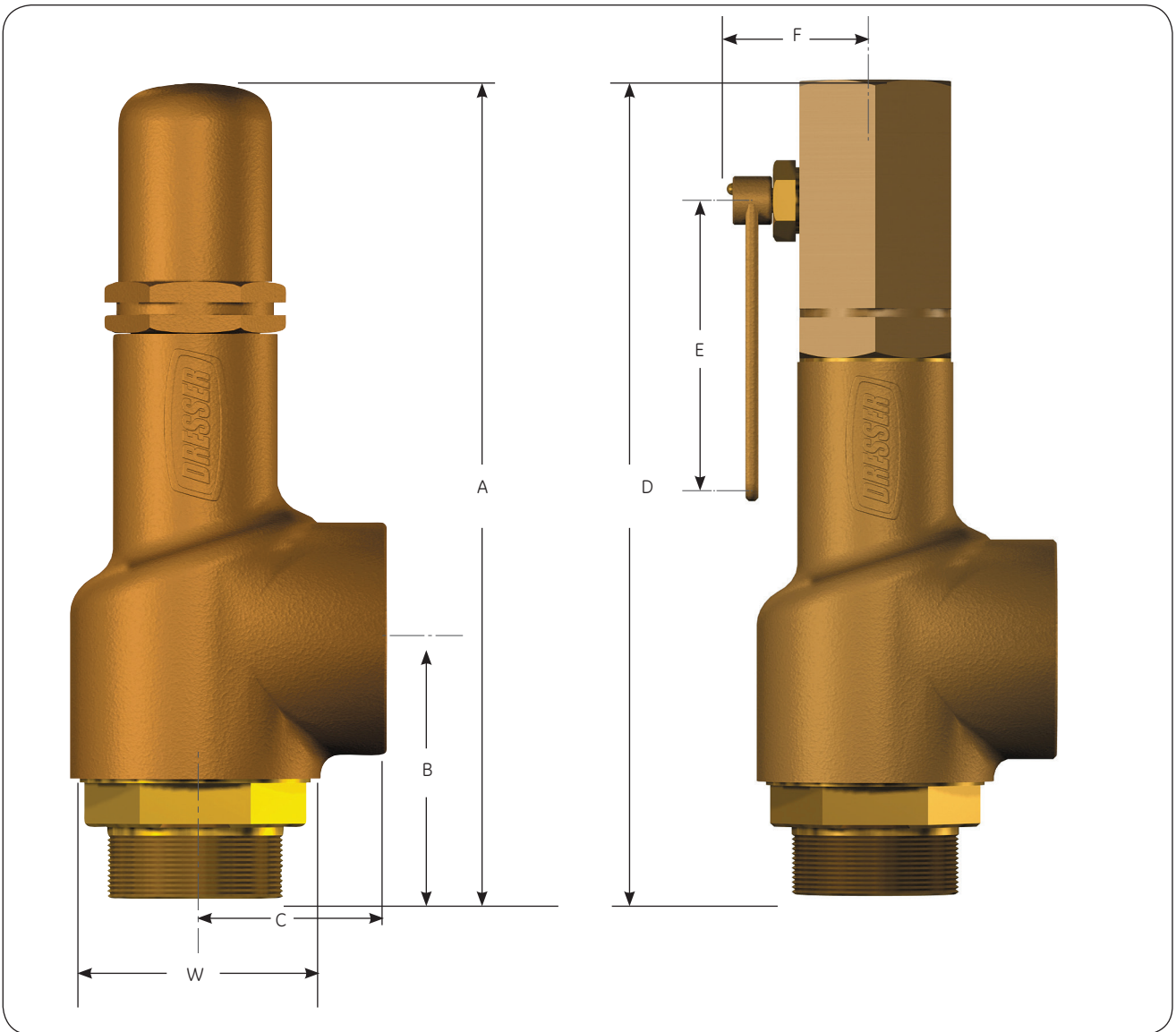

2478 Dimensions and weights

Inlet Size	Orifice	A		B		C		D		E		F		W		Dismantling Height		Approx. Weight		
		in.	mm	in.	mm	in.	mm	in.	mm	in.	mm	in.	mm	in.	mm	in.	mm	lbs	kg	
.50	12.7	D	6.56	166.7	2.25	57.2	1.44	36.5	6.69	169.9	2.44	61.9	1.25	31.8	1.75	44.5	7.75	196.9	1.8	0.8
.75	19.1	D	6.63	168.3	2.31	58.7	1.44	36.5	6.75	171.5	2.44	61.9	1.25	31.8	1.75	44.5	7.81	198.4	1.9	0.9
1.00	25.4	E	7.19	182.6	2.56	65.1	1.63	41.3	7.31	185.7	2.44	61.9	1.25	31.8	2.00	50.8	8.50	215.9	2.3	1.0
1.25	31.8	F	8.63	219.1	2.94	74.6	1.88	47.6	8.69	220.7	3.50	88.9	2.00	50.8	2.50	63.5	10.13	257.2	3.8	1.7
1.50	38.1	G	9.25	235.0	3.13	79.4	2.13	54.0	9.31	236.5	3.50	88.9	2.00	50.8	2.88	73.0	10.88	276.2	5.3	2.4
2.00	50.8	H	11.44	290.5	3.69	93.7	2.38	60.3	11.63	295.3	4.75	120.7	2.13	54.0	3.25	82.6	13.44	341.3	8.5	3.9
2.50	63.5	J	12.75	323.9	4.25	108.0	3.00	76.2	12.94	328.6	4.75	120.7	2.13	54.0	4.00	101.6	14.94	379.4	13.0	5.9

Orifice Capacities

Valve Capacities for Water (Not ASME Capacity Certified)

Based at 25 percent overpressure, showing 90 percent actual capacity.

Orifice Designation		D		E		F		G		H		J	
Orifice Area		in ²	cm ²	in ²	cm ²	in ²	cm ²	in ²	cm ²	in ²	cm ²	in ²	cm ²
Set Pressure		0.110	0.710	0.196	1.260	0.307	1.980	0.503	3.250	0.785	5.060	1.287	8.300
		Orifice Capacity											
psig	barg	gpm	L/min	gpm	L/min	gpm	L/min	gpm	L/min	gpm	L/min	gpm	L/min
5	3.44	7	26	10	37	17	64	31	117	47	177	73	276
10	6.89	9	34	14	52	24	90	44	166	67	253	103	389
15	10.34	11	41	17	64	29	109	54	204	82	310	127	480
20	13.78	13	49	19	71	33	124	63	238	94	355	146	552
25	17.23	15	56	22	83	37	140	70	264	105	397	164	620
30	20.68	16	60	24	90	41	155	77	291	115	435	179	677
35	24.13	17	64	26	98	44	166	83	314	125	473	194	734
40	27.57	18	68	27	102	47	177	89	336	133	503	207	783
45	31.02	20	75	29	109	50	189	94	355	141	533	219	829
50	34.47	21	79	31	117	53	200	99	374	149	564	231	874
55	37.92	22	83	32	121	55	208	104	393	156	590	243	919
60	41.36	23	87	34	128	58	219	109	412	163	617	253	957
65	44.81	23	87	35	132	60	227	113	427	170	643	264	999
70	48.26	24	90	36	136	62	234	117	442	176	666	274	1037
75	51.71	25	94	38	143	65	246	121	458	183	692	283	1071
80	55.15	26	98	39	147	67	253	125	473	189	715	293	1109
85	58.60	27	102	40	151	69	261	129	488	194	734	302	1143
90	62.05	28	105	41	155	71	268	133	503	200	757	310	1173
95	65.50	28	105	42	158	73	276	137	518	205	776	319	1207
100	68.94	29	109	43	162	75	283	140	529	211	798	327	1237
105	72.39	30	113	45	170	76	287	144	545	216	817	335	1268
110	75.84	31	117	46	174	78	295	147	556	221	836	343	1298
115	79.28	31	117	47	177	80	302	150	567	226	855	351	1328
120	82.73	32	121	48	181	82	310	154	582	231	874	358	1355
125	86.18	33	124	49	185	83	314	157	594	236	893	366	1385
130	89.63	33	124	50	189	85	321	160	605	240	908	373	1411
135	93.07	34	128	50	189	87	329	163	617	245	927	380	1438
140	96.52	34	128	51	193	88	333	166	628	249	942	387	1464
145	99.97	35	132	52	196	90	340	169	639	254	961	394	1491
150	103.42	36	136	53	200	91	344	172	651	258	976	401	1517
155	106.86	36	136	54	204	93	352	175	662	262	991	407	1540
160	110.31	37	140	55	208	94	355	177	670	267	1010	414	1567
165	113.76	37	140	56	211	96	363	180	681	271	1025	420	1589
170	117.21	38	143	57	215	97	367	183	692	275	1040	427	1616
175	120.65	38	143	57	215	99	374	186	704	279	1056	433	1639
180	124.10	39	147	58	219	100	378	188	711	283	1071	439	1661
185	127.55	40	151	59	223	101	382	191	723	287	1086	445	1684
190	131.00	40	151	60	227	103	389	193	730	291	1101	451	1707
195	134.44	41	155	61	230	104	393	196	741	294	1112	457	1729
200	137.89	41	155	61	230	105	397	198	749	298	1128	463	1752
205	141.34	42	158	62	234	107	405	201	760	302	1143	468	1771
210	144.78	42	158	63	238	108	408	203	768	305	1154	474	1794
215	148.23	43	162	64	242	109	412	206	779	309	1169	480	1816
220	151.68	43	162	64	242	111	420	208	787	313	1184	485	1835
225	155.13	44	166	65	246	112	423	210	794	316	1196	491	1858
230	158.57	44	166	66	249	113	427	213	806	320	1211	496	1877
235	162.02	45	170	67	253	114	431	215	813	323	1222	502	1900
240	165.47	45	170	67	253	116	439	217	821	327	1237	507	1919
245	168.92	46	174	68	257	117	442	219	829	330	1249	512	1938
250	172.36	46	174	69	261	118	446	222	840	333	1260	517	1957
255	175.81	46	174	69	261	119	450	224	847	337	1275	522	1975
260	179.26	47	177	70	264	120	454	226	855	340	1287	528	1998
265	182.71	47	177	71	268	121	458	228	863	343	1298	533	2017
270	186.15	48	181	71	268	123	465	230	870	346	1309	538	2036
275	189.60	48	181	72	272	124	469	233	882	350	1324	543	2055
280	193.05	49	185	73	276	125	473	235	889	353	1336	547	2070
285	196.50	49	185	73	276	126	476	237	897	356	1347	552	2089
290	199.94	50	189	74	280	127	480	239	904	359	1358	557	2108
295	203.39	50	189	75	283	128	484	241	912	362	1370	562	2127
300	206.84	50	189	75	283	129	488	243	919	365	1381	567	2146

Valve Configuration Code

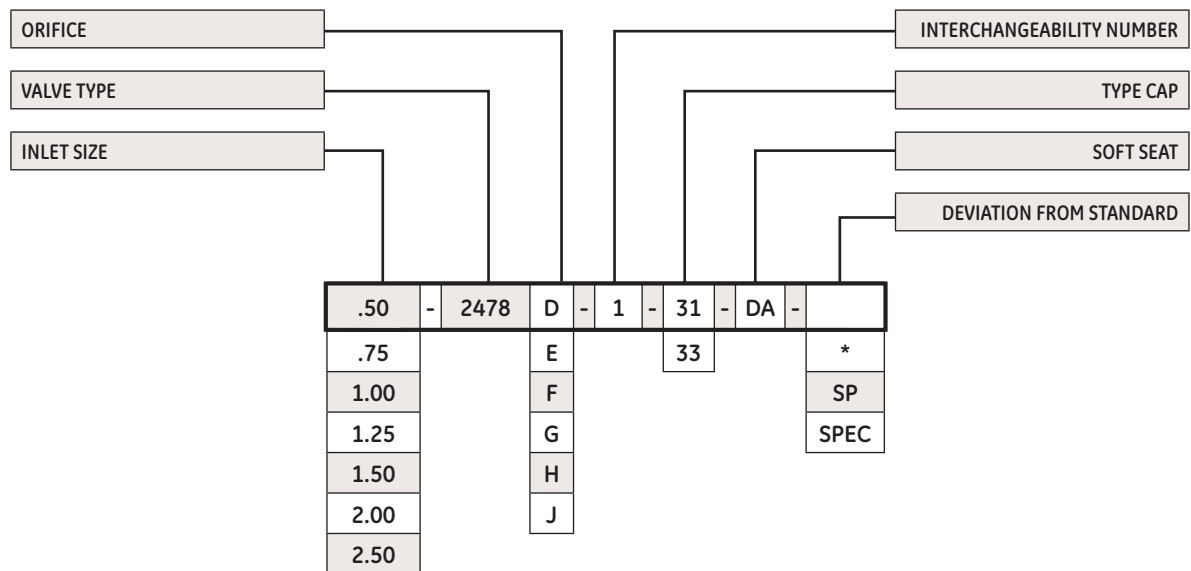

Standard Connection				
Inlet Size		Orifice	Area	
in.	mm		in ²	cm ²
.50	12.7	D	0.110	0.710
.75	19.05	D	0.110	0.710
1.00	25.4	E	0.196	1.265
1.25	31.75	F	0.307	1.981
1.50	38.1	G	0.503	3.245
2.00	50.8	H	0.785	5.065
2.50	63.5	J	1.287	8.303

Type Cap	
Designation	Trim
31	Screwed
33	Packed Cap Lever

Ordering a 2478 Series Safety Valve

How to Order a 2478 Series Safety Valve

Please Specify:	Example
Number of valves	3
Inlet size (MNPT)	1.50 in. (38.1 mm)
Type number of valve	2478-H-DA
Set pressure	100 psig (6.89 barg)
Operating pressure	80 psig (5.52 barg)
Operating, relieving and design temperature	100°F / 200°F / 400°F (37.8 °C / 93.3 °C / 204.4 °C)
Backpressure (constant, variable and/or built-up)	5 psig (0.34 barg) constant, 5 psig (0.34 barg) built-up additive
Allowable overpressure	25 percent
Orifice size	H
Required capacity	100 GWPM
Service (liquid)	Liquid
Non-code valve	-
Cap type (screwed, packed)	Screwed cap
Seat type (soft seat)	-
Material substitution	-
Accessories (spring coating)	-
Certification (for approval, for record)	-
Customer drawings (for approval, for record)	-
Note any special needs	-

DIRECT SALES OFFICE LOCATIONS

AUSTRALIA

Brisbane:
Phone: +61-7-3001-4319
Fax: +61-7-3001-4399

Perth:
Phone: +61-8-6595-7018
Fax: +61-8-6595-7299

Melbourne:
Phone: +61-3-8807-6002
Fax: +61-3-8807-6577

BELGIUM

Phone: +32-2-344-0970
Fax: +32-2-344-1123

BRAZIL

Phone: +55-19-2104-6900

CHINA
Phone: +86-10-5689-3600
Fax: +86-10-5689-3800

FRANCE

Courbevoie
Phone: +33-1-4904-9000
Fax: +33-1-4904-9010

GERMANY

Ratingen
Phone: +49-2102-108-0
Fax: +49-2102-108-111

INDIA

Mumbai
Phone: +91-22-8354790
Fax: +91-22-8354791

New Delhi

Phone: +91-11-2-6164175
Fax: +91-11-5-1659635

ITALY

Phone: +39-081-7892-111
Fax: +39-081-7892-208

JAPAN

Tokyo
Phone: +81-03-6871-9008
Fax: +81-03-6890-4620

KOREA

Phone: +82-2-2274-0748
Fax: +82-2-2274-0794

MALAYSIA

Phone: +60-3-2161-0322
Fax: +60-3-2163-6312

MEXICO

Phone: +52-55-3640-5060

THE NETHERLANDS

Phone: +31-15-3808666
Fax: +31-18-1641438

RUSSIA

Veliky Novgorod
Phone: +7-8162-55-7898
Fax: +7-8162-55-7921

Moscow

Phone: +7 495-585-1276
Fax: +7 495-585-1279

SAUDI ARABIA

Phone: +966-3-341-0278
Fax: +966-3-341-7624

SINGAPORE

Phone: +65-6861-6100
Fax: +65-6861-7172

SOUTH AFRICA

Phone: +27-11-452-1550
Fax: +27-11-452-6542

SOUTH & CENTRAL AMERICA AND THE CARIBBEAN

Phone: +55-12-2134-1201
Fax: +55-12-2134-1238

SPAIN

Phone: +34-93-652-6430
Fax: +34-93-652-6444

UNITED ARAB EMIRATES

Phone: +971-4-8991-777
Fax: +971-4-8991-778

UNITED KINGDOM

Bracknell
Phone: +44-1344-460-500
Fax: +44-1344-460-537

Skelmersdale

Phone: +44-1695-526-00
Fax: +44-1695-526-01

UNITED STATES

Massachusetts
Phone: +1-508-586-4600
Fax: +1-508-427-8971

Corpus Christi, Texas
Phone: +1-361-881-8182
Fax: +1-361-881-8246

Deer Park, Texas
Phone: +1-281-884-1000
Fax: +1-281-884-1010

Houston, Texas
Phone: +1-281-671-1640
Fax: +1-281-671-1735

www.geoilandgas.com/valves

*Denotes a trademark of the General Electric Company.

Other company names and product names used in this document are the registered trademarks or trademarks of their respective owners.

©2016 General Electric Company. All rights reserved.

GEA20201

09/2016

