

Consolidated* 1900 Series

Safety Relief Valve

The highly adaptable 1900 Series Safety Relief Valve is designed to meet numerous application requirements.



Table of Contents

- Conversion Table2
- 1900 Series Overview3
- How Pressure Relief Valves Operate.....7
- How Pressure Relief Valves Operate.....8
- Product Features - 1900 Flanged Series.....9
- Product Features - 1900 Flanged Series.....10
- 1900 Steam Trim (TD) Valves11
- 1900 Liquid Trim (LA) Valves.....12
- 1900 Restricted Lift Valves.....13
- Soft Seat Applications.....14
- 1900 Soft Seat (DA) Option.....15
- 1900 Soft Seat (DA) Option - How the Double Seal Works16
- Materials Conventional SRV 1900 Series.....17
- Materials For Gas, Vapor and Liquid Service 1900 Series (Conventional)18
- Materials Conventional SRV 1900-30 Series (Bellows).....19
- Materials for Gas, Vapor, and Liquid Service 1900-30 Series20
- Materials Conventional SRV 1900-35 Series (Balanced Bellows).....21
- Materials for Gas, Vapor, and Liquid Service1900-35 Series.....22
- Materials 1900 Soft Seat (DA) Option23
- Materials 1900 Steam Trim (TD) Option24
- Materials 1900 Liquid Trim (LA) Option25
- Materials 1900 / Special Material and Service Options / 1900 Sour Gas Trims26
- Materials 1900 Sour Gas Trims27
- Materials 1900 Hydrofluoric Acid (HA) Service28
- Materials / Corrosive Service 29-35
- Materials 36-41
- Accessories 42-48
- Dimensions and Weights..... 49-57
- Pressure / Temperature..... 58-87
- Capacities 88-94
- Valve Configuration Code 95-97
- Ordering a 1900 Safety Relief Valve 98

BHGE provides a full range of Consolidated pressure relief valve styles, sizes, options and configurations for multiple industries, applications, environments, and media. From spring-actuated to pilot-operated, each pressure relief valve is configured to offer safer process flow control in harsh environments.

Conversion Table

All the USCS values are converted to metric values using the following conversion factors:		
USCS Unit	Conversion Factor	Metric Unit
in.	25.4	mm
lb.	0.4535924	kg
in ²	6.4516	cm ²
ft ³ /min	0.02831685	m ³ /min
gal/min	3.785412	L/min
lb/hr	0.4535924	kg/hr
psig	0.06894757	barg
ft lb	1.3558181	Nm
°F	5/9 (°F-32)	°C

Scope of Design

1900 Series Overview

Standard Valve Connection - D Orifice						
Orifice Area	API			ASME		
	in ²	0.110		in ²	0.128	
	cm ²	0.710		cm ²	0.825	
Valve Type	Inlet			Outlet		
	Size		ANSI Std. Class	Size		ANSI Std. Class
	in.	mm		in.	mm	
1905	1.00	25.4	150	2.00	50.8	150
1906	1.00	25.4	300	2.00	50.8	150
1910	1.00	25.4	300	2.00	50.8	150
1912	1.00	25.4	600	2.00	50.8	150
1914	1.50	38.1	900	2.00	50.8	300
1916	1.50	38.1	1500	2.00	50.8	300
1918	1.50	38.1	2500	3.00	76.2	300
1920	1.00	25.4	300	2.00	50.8	150
1922	1.00	25.4	600	2.00	50.8	150
1924	1.50	38.1	900	2.00	50.8	300
1926	1.50	38.1	1500	2.00	50.8	300
1928	1.50	38.1	2500	3.00	76.2	300

Standard Valve Connection - E Orifice						
Orifice Area	API			ASME		
	in ²	0.196		in ²	0.228	
	cm ²	1.265		cm ²	1.470	
Valve Type	Inlet			Outlet		
	Size		ANSI Std. Class	Size		ANSI Std. Class
	in.	mm		in.	mm	
1905	1.00	25.4	150	2.00	50.8	150
1906	1.00	25.4	300	2.00	50.8	150
1910	1.00	25.4	300	2.00	50.8	150
1912	1.00	25.4	600	2.00	50.8	150
1914	1.50	38.1	900	2.00	50.8	300
1916	1.50	38.1	1500	2.00	50.8	300
1918	1.50	38.1	2500	3.00	76.2	300
1920	1.00	25.4	300	2.00	50.8	150
1922	1.00	25.4	600	2.00	50.8	150
1924	1.50	38.1	900	2.00	50.8	300
1926	1.50	38.1	1500	2.00	50.8	300
1928	1.50	38.1	2500	3.00	76.2	300

Standard Valve Connection - F Orifice						
Orifice Area	API			ASME		
	in ²	0.307		in ²	0.357	
	cm ²	1.981		cm ²	2.302	
Valve Type	Inlet			Outlet		
	Size		ANSI Std. Class	Size		ANSI Std. Class
	in.	mm		in.	mm	
1905	1.50	38.1	150	2.00	50.8	150
1906	1.50	38.1	300	2.00	50.8	150
1910	1.50	38.1	300	2.00	50.8	150
1912	1.50	38.1	600	2.00	50.8	150
1914	1.50	38.1	900	3.00	76.2	300
1916	1.50	38.1	1500	3.00	76.2	300
1918	1.50	38.1	2500	3.00	76.2	300
1920	1.50	38.1	300	2.00	50.8	150
1922	1.50	38.1	600	2.00	50.8	150
1924	1.50	38.1	900	3.00	76.2	300
1926	1.50	38.1	1500	3.00	76.2	300
1928	1.50	38.1	2500	3.00	76.2	300

Standard Valve Connection - G Orifice						
Orifice Area	API			ASME		
	in ²	0.503		in ²	0.585	
	cm ²	3.245		cm ²	3.774	
Valve Type	Inlet			Outlet		
	Size		ANSI Std. Class	Size		ANSI Std. Class
	in.	mm		in.	mm	
1905	1.50	38.1	150	3.00	76.2	150
1906	1.50	38.1	300	3.00	76.2	150
1910	1.50	38.1	300	3.00	76.2	150
1912	1.50	38.1	600	3.00	76.2	150
1914	1.50	38.1	900	3.00	76.2	300
1916	2.00	50.8	1500	3.00	76.2	300
1918	2.00	50.8	2500	3.00	76.2	300
1920	1.50	38.1	300	3.00	76.2	150
1922	1.50	38.1	600	3.00	76.2	150
1924	1.50	38.1	900	3.00	76.2	300
1926	2.00	50.8	1500	3.00	76.2	300
1928	2.00	50.8	2500	3.00	76.2	300

Scope of Design

1900 Series Overview

Standard Valve Connection - H Orifice						
Orifice Area	API			ASME		
	in ²	0.785		in ²	0.913	
	cm ²	5.065		cm ²	5.888	
Valve Type	Inlet			Outlet		
	Size		ANSI Std. Class	Size		ANSI Std. Class
	in.	mm		in.	mm	
1905	1.50	38.1	150	3.00	76.2	150
1906	1.50	38.1	300	3.00	76.2	150
1910	2.00	50.8	300	3.00	76.2	150
1912	2.00	50.8	600	3.00	76.2	150
1914	2.00	50.8	900	3.00	76.2	150
1916	2.00	50.8	1500	3.00	76.2	300
1920	2.00	50.8	300	3.00	76.2	150
1922	2.00	50.8	600	3.00	76.2	150
1924	2.00	50.8	900	3.00	76.2	150
1926	2.00	50.8	1500	3.00	76.2	300

Standard Valve Connection - J Orifice						
Orifice Area	API			ASME		
	in ²	1.287		in ²	1.496	
	cm ²	8.303		cm ²	9.652	
Valve Type	Inlet			Outlet		
	Size		ANSI Std. Class	Size		ANSI Std. Class
	in.	mm		in.	mm	
1905	2.00	50.8	150	3.00	76.2	150
1906	2.00	50.8	300	3.00	76.2	150
1910	3.00	76.2	300	4.00	101.6	150
1912	3.00	76.2	600	4.00	101.6	150
1914	3.00	76.2	900	4.00	101.6	150
1916	3.00	76.2	1500	4.00	101.6	300
1920	3.00	76.2	300	4.00	101.6	150
1922	3.00	76.2	600	4.00	101.6	150
1924	3.00	76.2	900	4.00	101.6	150
1926	3.00	76.2	1500	4.00	101.6	300

Standard Valve Connection - K Orifice						
Orifice Area	API			ASME		
	in ²	1.838		in ²	2.138	
	cm ²	11.858		cm ²	13.794	
Valve Type	Inlet			Outlet		
	Size		ANSI Std. Class	Size		ANSI Std. Class
	in.	mm		in.	mm	
1905	3.00	76.2	150	4.00	101.6	150
1906	3.00	76.2	300	4.00	101.6	150
1910	3.00	76.2	300	4.00	101.6	150
1912	3.00	76.2	600	4.00	101.6	150
1914	3.00	76.2	900	6.00	152.4	150
1916	3.00	76.2	1500	6.00	152.4	300
1920	3.00	76.2	300	4.00	101.6	150
1922	3.00	76.2	600	4.00	101.6	150
1924	3.00	76.2	900	6.00	152.4	150
1926	3.00	76.2	1500	6.00	152.4	300

Standard Valve Connection - L Orifice						
Orifice Area	API			ASME		
	in ²	2.853		in ²	3.317	
	cm ²	18.406		cm ²	21.400	
Valve Type	Inlet			Outlet		
	Size		ANSI Std. Class	Size		ANSI Std. Class
	in.	mm		in.	mm	
1905	3.00	76.2	150	4.00	101.6	150
1906	3.00	76.2	300	4.00	101.6	150
1910	4.00	101.6	300	6.00	152.4	150
1912	4.00	101.6	600	6.00	152.4	150
1914	4.00	101.6	900	6.00	152.4	150
1916	4.00	101.6	1500	6.00	152.4	150
1920	4.00	101.6	300	6.00	152.4	150
1922	4.00	101.6	600	6.00	152.4	150
1924	4.00	101.6	900	6.00	152.4	150
1926	4.00	101.6	1500	6.00	152.4	150

Scope of Design

1900 Series Overview

Standard Valve Connection - M Orifice						
Orifice Area	API			ASME		
	in ²	3.600		in ²	4.186	
	cm ²	23.226		cm ²	27.006	
Valve Type	Inlet			Outlet		
	Size		ANSI Std. Class	Size		ANSI Std. Class
	in.	mm		in.	mm	
1905	4.00	101.6	150	6.00	152.4	150
1906	4.00	101.6	300	6.00	152.4	150
1910	4.00	101.6	300	6.00	152.4	150
1912	4.00	101.6	600	6.00	152.4	150
1914	4.00	101.6	900	6.00	152.4	150
1920	4.00	101.6	300	6.00	152.4	150
1922	4.00	101.6	600	6.00	152.4	150
1924	4.00	101.6	900	6.00	152.4	150

Standard Valve Connection - N Orifice						
Orifice Area	API			ASME		
	in ²	4.340		in ²	5.047	
	cm ²	28.000		cm ²	32.561	
Valve Type	Inlet			Outlet		
	Size		ANSI Std. Class	Size		ANSI Std. Class
	in.	mm		in.	mm	
1905	4.00	101.6	150	6.00	152.4	150
1906	4.00	101.6	300	6.00	152.4	150
1910	4.00	101.6	300	6.00	152.4	150
1912	4.00	101.6	600	6.00	152.4	150
1914	4.00	101.6	900	6.00	152.4	150
1920	4.00	101.6	300	6.00	152.4	150
1922	4.00	101.6	600	6.00	152.4	150
1924	4.00	101.6	900	6.00	152.4	150

Standard Valve Connection - P Orifice						
Orifice Area	API			ASME		
	in ²	6.380		in ²	7.417	
	cm ²	41.161		cm ²	47.852	
Valve Type	Inlet			Outlet		
	Size		ANSI Std. Class	Size		ANSI Std. Class
	in.	mm		in.	mm	
1905	4.00	101.6	150	6.00	152.4	150
1906	4.00	101.6	300	6.00	152.4	150
1910	4.00	101.6	300	6.00	152.4	150
1912	4.00	101.6	600	6.00	152.4	150
1914	4.00	101.6	900	6.00	152.4	150
1920	4.00	101.6	300	6.00	152.4	150
1923	4.00	101.6	600	6.00	152.4	150
1924	4.00	101.6	900	6.00	152.4	150

Standard Valve Connection - Q Orifice						
Orifice Area	API			ASME		
	in ²	11.050		in ²	12.850	
	cm ²	71.290		cm ²	82.903	
Valve Type	Inlet			Outlet		
	Size		ANSI Std. Class	Size		ANSI Std. Class
	in.	mm		in.	mm	
1905	6.00	152.4	150	8.00	203.2	150
1906	6.00	152.4	300	8.00	203.2	150
1910	6.00	152.4	300	8.00	203.2	150
1912	6.00	152.4	600	8.00	203.2	150
1920	6.00	152.4	300	8.00	203.2	150
1922	6.00	152.4	600	8.00	203.2	150

Standard Valve Connection - R Orifice						
Orifice Area	API			ASME		
	in ²	16.000		in ²	18.600	
	cm ²	103.226		cm ²	120.000	
Valve Type	Inlet			Outlet		
	Size		ANSI Std. Class	Size		ANSI Std. Class
	in.	mm		in.	mm	
1905	6.00	152.4	150	8.00	203.2	150
1906	6.00	152.4	300	8.00	203.2	150
1910	6.00	152.4	300	10.00	254.0	150
1912	6.00	152.4	600	10.00	254.0	150
1920	6.00	152.4	300	8.00	203.2	150
1922	6.00	152.4	600	10.00	254.0	150

Standard Valve Connection - T Orifice						
Orifice Area	API			ASME		
	in ²	26.000		in ²	30.210	
	cm ²	167.742		cm ²	194.903	
Valve Type	Inlet			Outlet		
	Size		ANSI Std. Class	Size		ANSI Std. Class
	in.	mm		in.	mm	
1905	8.00	203.2	150	10.00	254.0	150
1906	8.00	203.2	300	10.00	254.0	150
1910	8.00	203.2	300	10.00	254.0	150
1912	8.00	203.2	600	10.00	254.0	150
1920	8.00	203.2	300	10.00	254.0	150
1922	8.00	203.2	600	10.00	254.0	150

Scope of Design

1900 Series Overview

Standard Valve Connection - U Orifice						
Orifice Area	API			ASME		
	in ²	N/A		in ²	35.099	
	cm ²	N/A		cm ²	226.445	
Valve Type	Inlet			Outlet		
	Size		ANSI Std. Class	Size		ANSI Std. Class
	in.	mm		in.	mm	
1905	8.00	203.2	150	10.00	254.0	150
1906	8.00	203.2	300	10.00	254.0	150
1910	8.00	203.2	300	10.00	254.0	150
1920	8.00	203.2	300	10.00	254.0	150

Standard Valve Connection - V Orifice						
Orifice Area	API			ASME		
	in ²	N/A		in ²	50.260	
	cm ²	N/A		cm ²	324.257	
Valve Type	Inlet			Outlet		
	Size		ANSI Std. Class	Size		ANSI Std. Class
	in.	mm		in.	mm	
1905	10.00	254.0	150	14.00	355.6	150
1906	10.00	254.0	300	14.00	355.6	150
1910	10.00	254.0	300	14.00	355.6	150
1920	10.00	254.0	300	14.00	355.6	150

Standard Valve Connection - W Orifice						
Orifice Area	API			ASME		
	in ²	N/A		in ²	78.996	
	cm ²	N/A		cm ²	509.651	
Valve Type	Inlet			Outlet		
	Size		ANSI Std. Class	Size		ANSI Std. Class
	in.	mm		in.	mm	
1905	12.00	304.8	150	16.00	406.4	150
1906	12.00	304.8	300	16.00	406.4	150
1910	12.00	304.8	300	16.00	406.4	150
1920	12.00	304.8	300	16.00	406.4	150

Scope of Design

How Pressure Relief Valves Operate

All pressure relief valves operate by using inlet-system pressure to overcome a spring load. As a result, the valve can relieve a defined capacity.

Closed

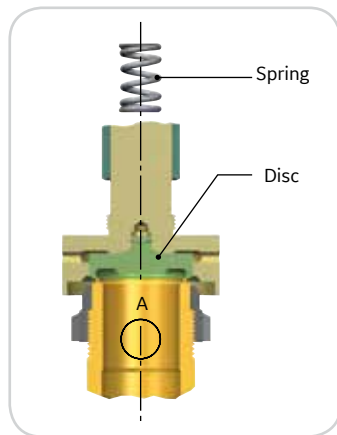

When the valve is closed during normal operation (See Figure Closed), the spring force resists the vessel pressure acting against the seating surfaces (area A). As vessel pressure increases, the pressure at (A) tends to equalize the spring force and the pressure holding the seats together approaches zero.

Partially Open

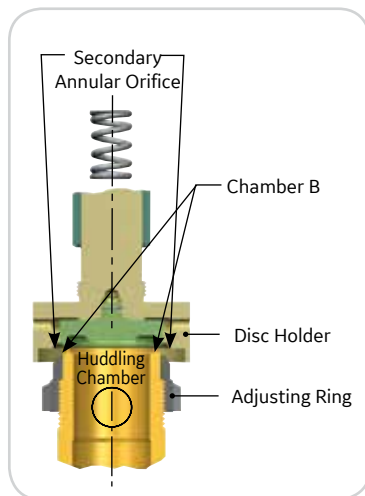

In vapor or gas service the valve may “simmer” before it will “pop.” When the vessel pressure increases to within one to two percent of the set pressure, media will audibly move past the seating surfaces into Chamber (B). Flow restriction in the secondary annular orifice causes pressure can now act

over a larger area, an additional force is available to overcome the spring force. By adjusting the “adjusting ring”, the opening in the secondary annular orifice can be altered, which controls pressure build-up in chamber (B). This controlled pressure build-up in chamber (B) will overcome the spring force, causing the disc to move away from the nozzle seat and the valve to “pop” open.

Fully Open

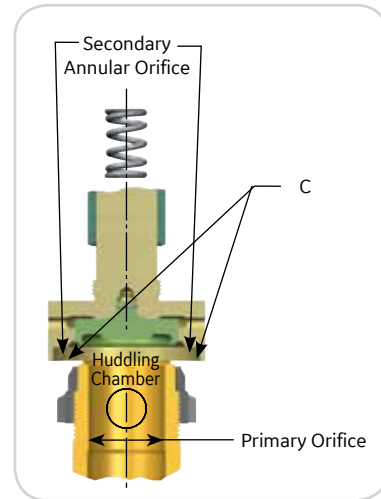

Once the valve has opened, an additional pressure build-up occurs at (C) (See Figure Fully Open). This is due to the sudden flow increase and the restriction to flow through another annular orifice formed between the inner edge of the disc holder and the outside diameter of the adjusting ring. These additional forces at (C) cause the disc to lift substantially at “pop.”

Flow is restricted by the opening between the nozzle seat and disc seat until the disc seat has been lifted from the nozzle seat by approximately one-quarter of the nozzle-throat diameter. After the disc has attained this degree of lift, flow is restricted by the primary orifice rather than by the area between the seating surfaces.

Blowdown (the difference between opening and closing pressure) can be controlled within limits by positioning the single adjusting ring. Blowdown is caused when the spring force is unable to overcome the summation of the forces at (A), (B), and (C) until the pressure at (A) drops below the set pressure.

Scope of Design

How Pressure Relief Valves Operate

Flow path of fluid through the valve

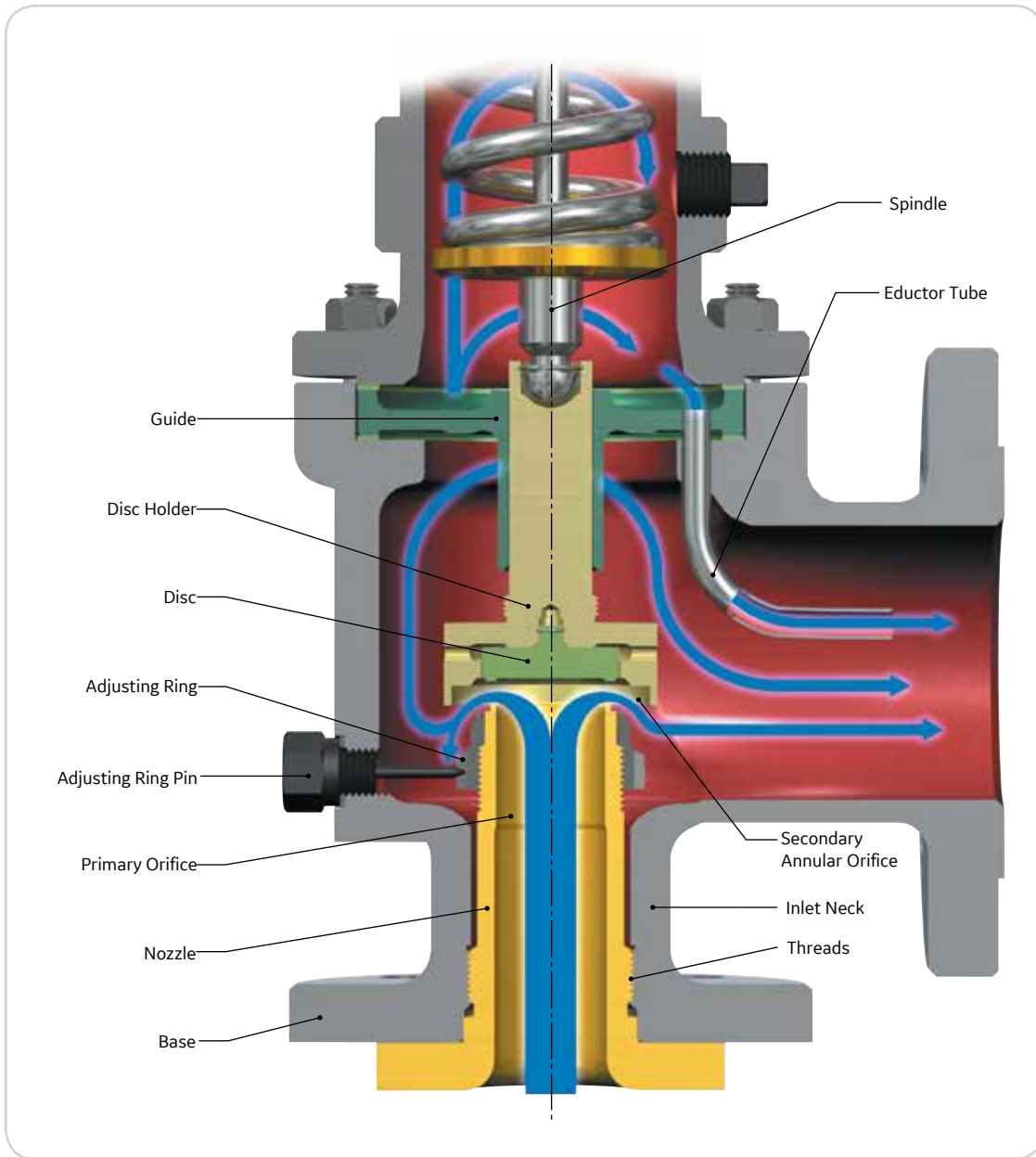

Note:

Above Figure reflects the flow path of fluid through the valve. It is significant to recognize that the system pressure enters through the nozzle and remains at a high pressure until it expands through the secondary annular orifice. Pressure downstream of the secondary annular orifice is much lower than the system pressure. The upper portion of the valve base plus the outlet flange are of a lower pressure rating than the inlet side of the valve.

Blowdown settings: Production testing required by manufacturers of safety relief valves is governed by ASME Section VIII, UG-136 (d), which does not require the setting of blowdown during production test. Adjusting rings on the 1900 flanged safety relief valve series are factory adjusted to predetermined ring settings. This will provide a consistent opening and closing pressure on the safety relief valve.

Scope of Design

Product Features - 1900 Flanged Series

Adjusting Ring

The adjusting ring in the Consolidated safety relief valve is preset to predetermined positions before the valve is put into service. Presetting makes it less necessary to pop the valve in service in order to ascertain that the ring has been set properly to achieve the necessary lift and relieving capacity.

Simple Blowdown Adjustment

A single adjusting ring adjusts blowdown, or reseating pressure, in the safety relief valve. When the ring is moved upward, blowdown is increased (lowering the reseating pressure), and when it is moved downward, the blowdown is decreased (raising the reseating pressure). In comparison, when valves have two or more adjusting rings, each affects valve action as well as blowdown.

Minimum Guiding Area

Guiding areas greater than those required to align the seating surfaces are undesirable in a safety relief valve, especially for valves used in the process industries. The smaller the valve's guiding area (when corrosion or contamination from the flowing medium builds up in the valve guiding surfaces) the less the tendency of the guiding area to stick and hinder valve operation.

Nozzle

The nozzle is a pressure-containing component in constant contact with the process media in both the open and closed valve positions. To promote reliability and safety, Consolidated flanged SRV nozzles are constructed from forgings, investment castings or centrifugal castings.

Spindle Pocket Connection

The connection between the spindle and disc holder in a Consolidated safety relief valve is a positive method of attachment. The Inconel snap ring and groove design make it virtually impossible to remove the spindle from the disc holder, unless the ring is compressed intentionally. This design requires a minimum amount of effort to disassemble during maintenance.

Design Simplicity

Consolidated safety relief valves use a minimum number of component parts, which results in a savings by minimizing spare parts inventory and simplifying valve maintenance.

Maximum Seat Tightness

Seat finish in a safety relief valve is critically important; otherwise, valve leakage can occur. Consolidated safety relief valve seats are precision-machined and lapped, which promotes positive seating and prevents loss of contained media.

The Thermodisc* design offers a tighter closure and compensates for temperature variations around the periphery of the nozzle. Thermal distortion, which produces seat leakage, is minimized in steam service.

Cap and Lever Interchangeability

Sometimes it may be necessary to change the type of cap or lever in the field after a valve has been installed. All Consolidated safety relief valves are supplied so they can be converted to any type of lever or cap desired. It is not necessary to remove the valve from the installation, and the set pressure will not be affected when making such a change.

Valve Interchangeability

A Consolidated safety relief valve may be converted from the standard, conventional type valve to the bellows type, or to the O-ring seat seal type, Thermodisc seat liquid trim, or vice versa, requiring a minimum number of new parts for lower costs.

Quality Material

All Consolidated safety relief valve castings and forgings are made to ASTM and ASME specifications and are subject to many rigid inspections. These rigorous processes, coupled with quality workmanship, promote a long, trouble-free valve life.

Scope of Design

Product Features - 1900 Flanged Series

Reduction of Valve Bonnet Pressure

Closed bonnet valves are subject to variable pressure past the guiding surfaces when the valve is open. This adds a variable force to that of the spring, which can affect valve performance. An eductor tube can help reduce excess bonnet pressure and promote good valve opening and closing action.

The eductor tube reduces bonnet pressure by pulling discharging fluids out of the bonnet faster than the fluids can enter past the guiding surfaces. Consequently, the tube acts as a siphon through the drawing effect of the flow through the outlet side of the valve.

Eductor Tube Reduces Bonnet Pressure

During valve discharge, media flows through the clearance between the disc holder and guide, building up bonnet pressure. This adds a variable force to the spring force, which inhibits valve lift. The eductor effect of the medium flowing at high velocity through the valve outlet reduces bonnet pressure.

The greater lifting force (resulting from a reduction in bonnet pressure) introduces important advantages:

1. Uniform response to blowdown control adjustment
2. Positive, full-rated capacity at low overpressures
3. Better operation at higher back pressures with the eductor tube
4. Stability of valve lift and capacity during operation
5. When the valve opens, an increase in lifting force that breaks up slight corrosive deposits or surface film accumulates on the guiding surfaces and hinders valve action. (For severe corrosion applications, a bellows valve is recommended.)

Eductor Tube

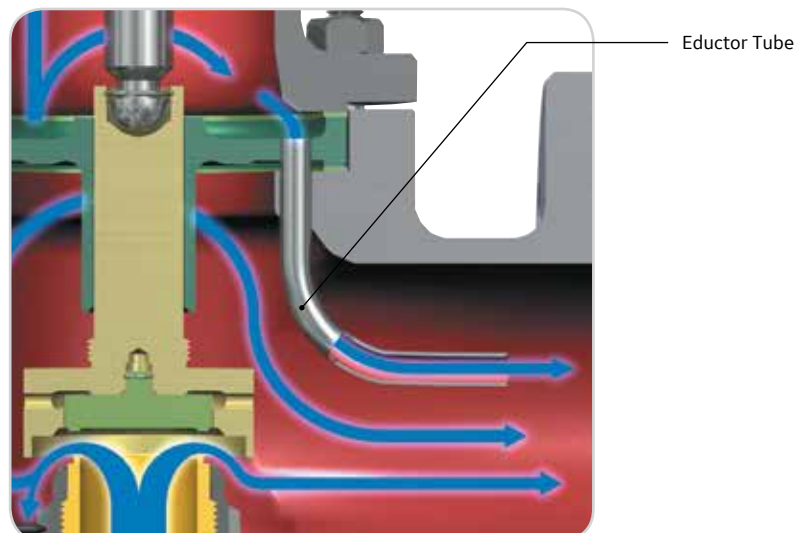

Scope of Design

1900 Steam Trim (TD) Valves

The 1900 TD is specifically configured for steam service and organic heat-transfer media. It is certified to ASME Code Section VIII.

The Thermodisc is a specifically configured disc for use with high-temperature fluids. The Thermodisc concept has consistently contributed to valve tightness during more than 40 years of field-proven performance.

A Thermodisc is required for steam service.

The martensitic stainless steel disc construction promotes high strength and toughness. As the valve set point is approached, the pressure-sealing effect of the Thermodisc assists in the tightness of the seat as does the rapid thermal equalization that occurs due to the thin-sealing section.



1900 Disc Design Availability											
Valve Type	Disc Design										ASME Code Section
	Standard Solid Disc					Thermodisc ¹					
	Steam	Liquid	Liquid Organic Heat Transfer Media	Vapor Organic Heat Transfer Media	Vapor	Steam	Liquid	Liquid Organic Heat Transfer Media	Vapor Organic Heat Transfer Media	Vapor	
1900	-	X	X	X	X	X	-	-	X	-	VIII
1900-30	-	X	X	X	X	X	-	-	X	-	VIII
1900-35	-	X	X	X	X	X	-	-	X	-	VIII
1900/P1 ²	-	-	-	-	-	X ³	X ⁴	-	X	-	I or VIII
1900/P3 ²	-	-	-	-	-	X ³	-	-	X	-	I or VIII

Notes:

1. Thermodisc is provided in one material only, a specially heat treated martensitic stainless steel.
2. Refer to the 1900/P Series section for product information.
3. 1900/P Series are not intended for overpressure protection of power boiler drum, superheater or reheater equipment.
4. Consult the factory for special conditions that require the use of an ASME Code Section I pressure relief valve. Except for liquid thermal relief applications, the "P" Series are not intended for liquid service.

Scope of Design

1900 Liquid Trim (LA) Valves

The Liquid Trim LA (Liquid Application) represents the second generation of ASME B and PVC, Section VIII certified liquid-trim valves and must be used for all liquid applications for both ASME B and PVC, Section VIII certified and non-certified valves.

Liquid applications are defined as:

1. The fluid remains liquid while flowing through the valve
2. Flowing fluid flashes going through the valve
3. For ASME B and PVC, Section VIII, certified and non-certified thermal-relief applications (thermal relief is to prevent excessive pressure caused by thermal

expansion of trapped liquids). The LA trim offers blowdown performance with ranges from 7 percent to 12 percent below the set pressure. This valuable feature offers media conservation, a positive lift and smooth, chatter-free operation. Because of the short blowdown performance of this design, it is critical that the inlet connection always supports a pressure drop of 3 percent or less from the vessel to the valve as recommended by API 520.

Conversion of existing 1900 Series valves to liquid trim is available through the factory or your local Green Tag Center*.

Liquid Service Internals

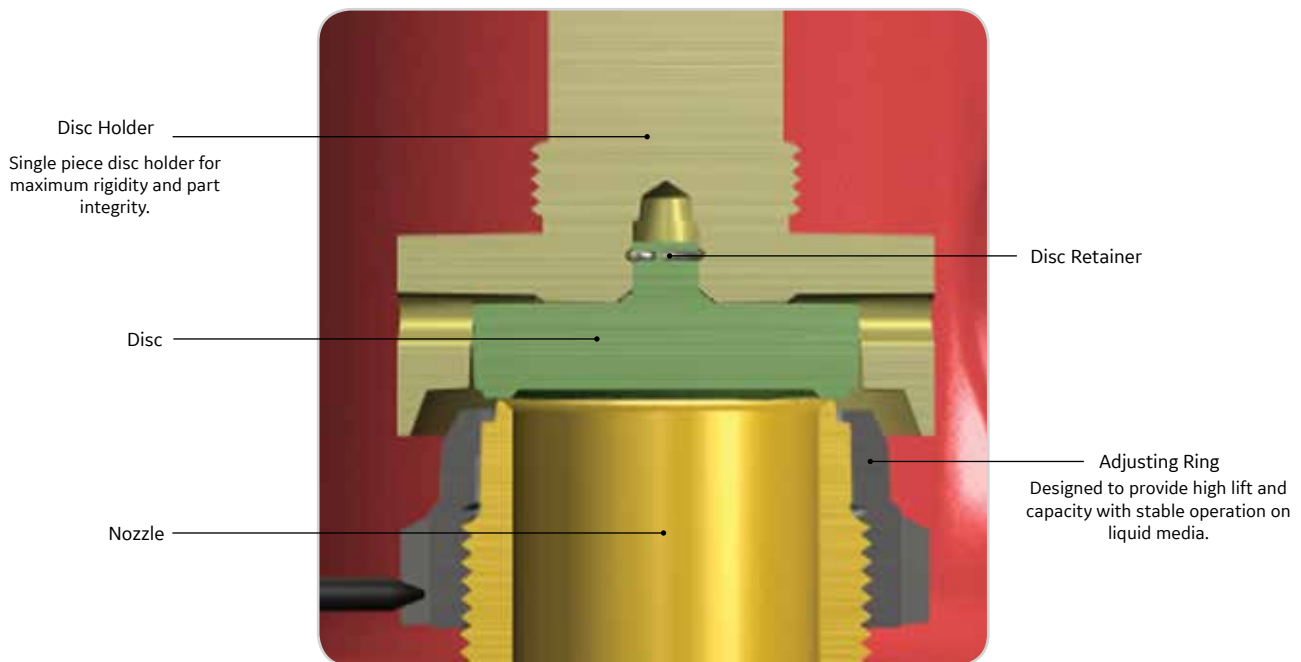

Scope of Design

1900 Restricted Lift Valves

We offer the 1900 Series in orifice sizes ranging from the smallest “D” size to the largest “W” size. In order to accomplish certain valve functions, some special considerations should be made as shown below with the D and E orifice designs.

The D and E valves are restricted-lift versions of the “F” orifice valve. The lift is restricted by a limit washer to provide the equivalent effective orifice area for a “D” or “E” orifice. This design is available with a balanced bellows configuration for back pressure applications.

The standard 1900 Series valves are available with restricted lifts in orifices ranging from “F” to “W” for compressible media only.

Restricted Lift

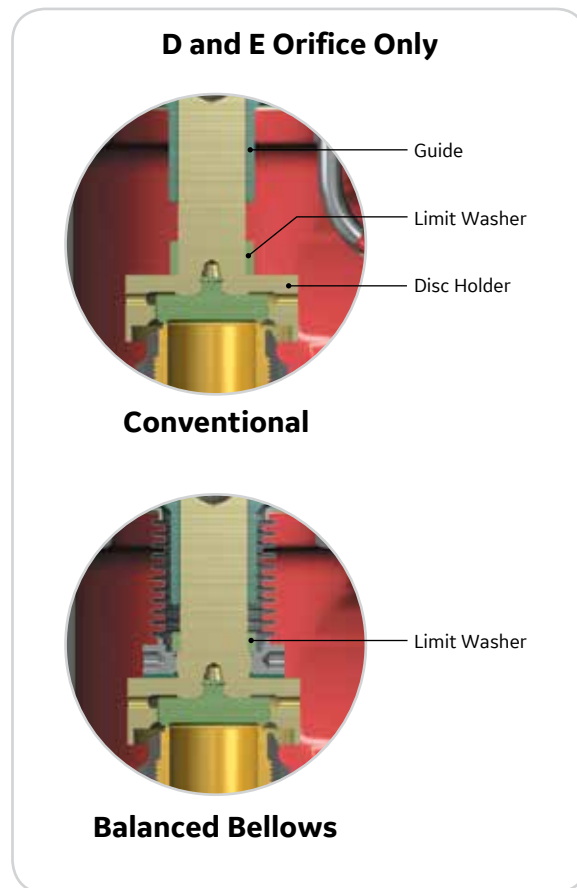

Scope of Design

Soft Seat Applications

Operating and Set Pressures

Where the operating pressure is close to the set pressure, seat tightness can be maintained at relatively higher operating pressures.

Seats Positioned for Correct Alignment

Mechanical vibration and pressure waves could lift the valve disc with each stroke and may cause flat metal-to-metal seats to rub together and become damaged.

The 45-degree metal-to-metal load-bearing seats in the Consolidated O-ring seat seal promote true alignment aided by full system pressure behind the O-ring, which effectively seals against leakage.

Corrosive Services

In some services, seating surface corrosion is the cause of valve leakage. In this type of service, the Consolidated O-ring seat seal will protect the metal seat on the nozzle against contact of the corrosive fluid thereby maintaining greater tightness.

1900-DA soft seats without bellows

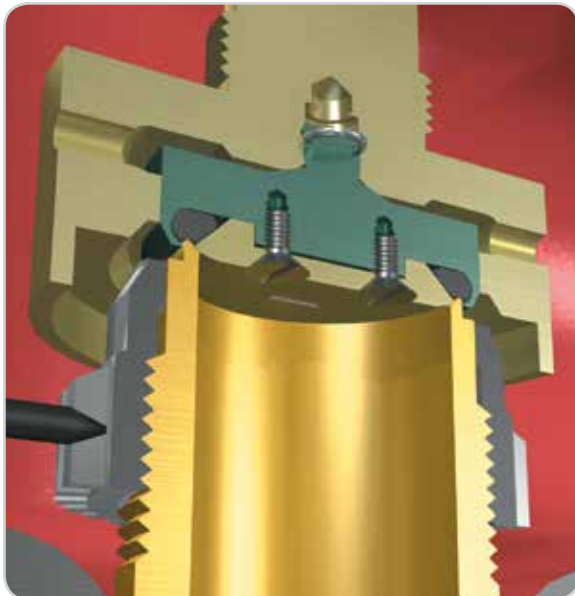

Foreign Matter and Slurry Service

Many times foreign material such as pipe scale, welding beads, sand and dust particles may damage the metal-to-metal seating surfaces in a valve of this type when it is open and flowing.

The Consolidated O-ring seat seal can absorb the impact of most foreign particles without damage.

Hot Water Boiler Service

When a safety relief valve opens, hot water flashes into steam at the seating surfaces, and solid particles that float to the water surface are driven against the seating surfaces at steam velocities. Consolidated O-ring seat seal valves can withstand this type of service and remain tight to a greater degree than metal-to-metal seat valves.

GE uses proven quality Teflon® O-ring seats for this service. In some pressure and temperature applications, Teflon is not resilient, and leakage may occur.

Benefits

Safety Relief Valve leakage that is aggravated by any cause is usually costly. In many cases, an expensive product is lost and maintenance costs increase. Consolidated O-ring seat seal valves are configured to eliminate leakage in troublesome applications and reduce overall costs. Should leakage occur, it is simpler and less expensive to replace the O-ring than to maintain metal-to-metal seats.

O-ring Conversion

1900 Series Consolidated metal-seated valves can be converted to O-ring seat seals by installing a few basic parts provided in a conversion kit.

Scope of Design

1900 Soft Seat (DA) Option

The Double Seal Soft Seat

The double seal design incorporates the merits of both a soft seat and a metal seat design valve. The 45-degree metal seat offers the load-bearing surface to transmit spring force and the slotted O-ring retainer allows O-ring pressurization to accomplish the primary sealing function. This O-ring seal design can be used throughout the full pressure range of the valve. For pressure and temperature ratings of the seal, refer to the O-ring Selection Table in this section (pages 41 and 42).

Consolidated O-ring seat seal valves are bubble tight at 95 percent of set pressures over 100 psig (6.89 barg).

The following table reflects the percent of set pressure (popping pressure) at which the valve will be bubble tight on air.

Bubble Tight Pressures				
Set Pressure				Percent of Set Pressure
psig		barg		
min.	max.	min.	max.	
5	30	0.34	2.07	90%
31	50	2.14	3.45	92%
51	100	3.52	6.89	94%
101 to max. rating of valve		6.96 to max. rating of valve		95%

Consolidated O-ring seat seals provide positive closure at service pressures closer to the set pressure than is possible with metal-to-metal seats. This assures continuous, trouble-free service and complete valve tightness after numerous “pops.”

Note:

The Consolidated 1900 O-ring design features a secondary metal-to-metal seat that becomes effective if O-ring integrity is lost due to external fire or other causes. The retainer is lapped to the nozzle at assembly assuring seat tightness.

1900 Soft Seat (DA)

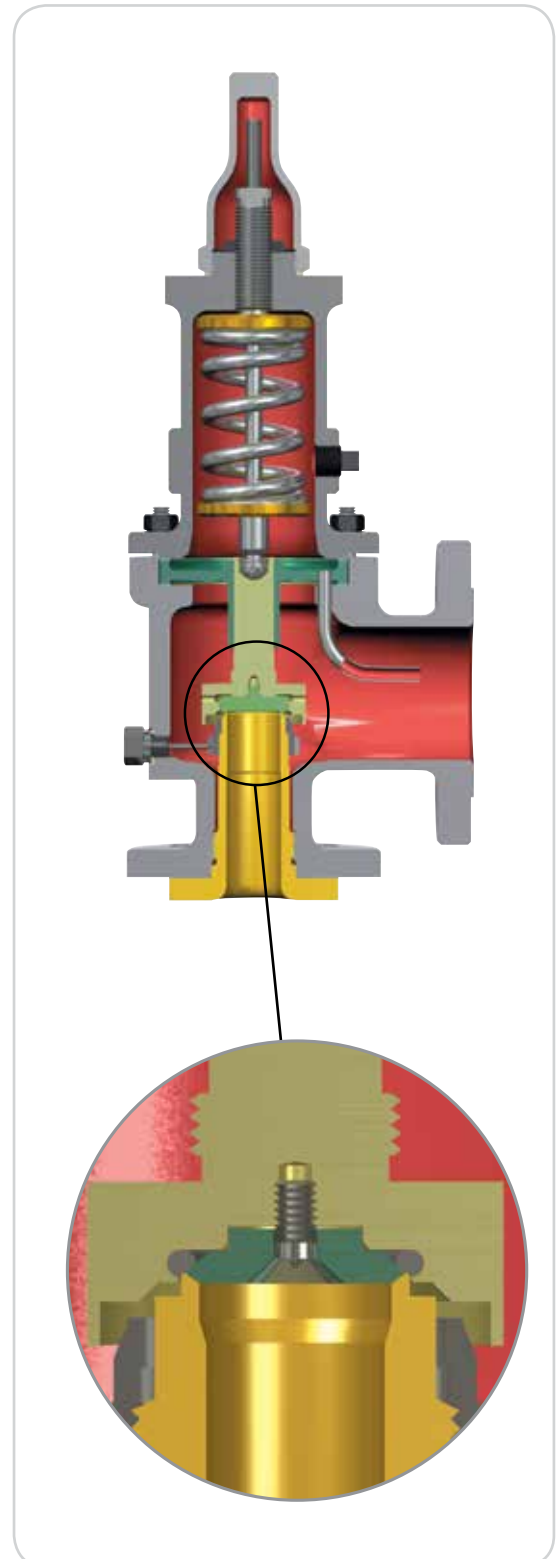

Scope of Design

1900 Soft Seat (DA) Option - How the Double Seal Works

Two unique features distinguish the Consolidated O-ring seat safety valve from other designs. These are the 45-degree metal-to-metal load bearing seats and the slotted O-ring retainer.

Double Seal

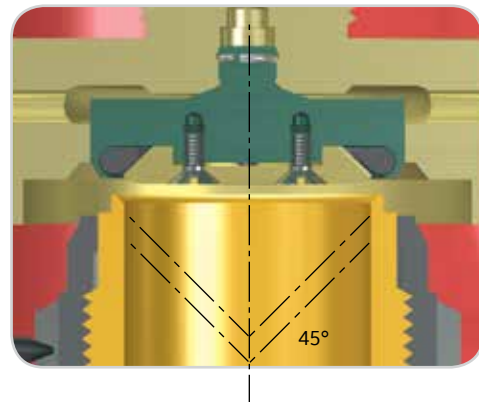

Three Essentials to a Tighter and More Secure Seat

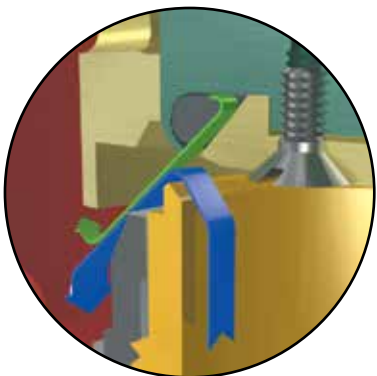
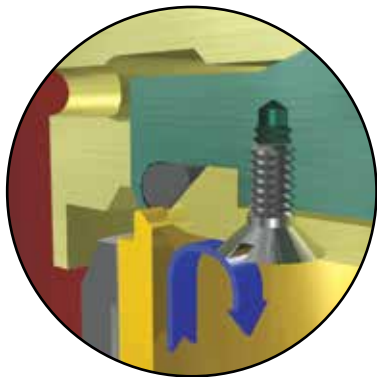

1) Concentric Alignment

The nozzle bore and O-ring retainer are both machined to an angle of 45 degrees. This ensures that as the valve disc opens and closes, the O-ring is aligned concentrically against the lip of the nozzle. Close tolerance between the nozzle and the body, or between the body and the disc guide and disc holder, also help to ensure a tight seal when the valve is closed. Accurate alignment coupled with the load bearing function of the O-ring retainer virtually eliminates O-ring abrasion from valve action.

2) Maximum Sealing Force

On the back side of the O-ring retainer there are two small slots. When the valve is closed, process media enters between the machined seat of the nozzle and the O-ring retainer and proceeds up the slots behind the O-ring. This pressure forces the O-ring against the lip of the nozzle and the curved recess of the disc holder. As the pressure within the valve rises to set point, the O-ring is pressed tightly against the nozzle to maintain maximum sealing force until break-away pressure is reached.

3) O-ring Retention

When the valve opens, the pressure behind the O-ring escapes from the same two slots on the O-ring retainer. This prevents the O-ring from being ejected. Additionally, the O-ring encapsulating retainer prevents the O-ring from being pulled from its setting by the high velocity, low pressure discharge inside the upper valve body.

Materials

Conventional Safety Relief Valve 1900 Series

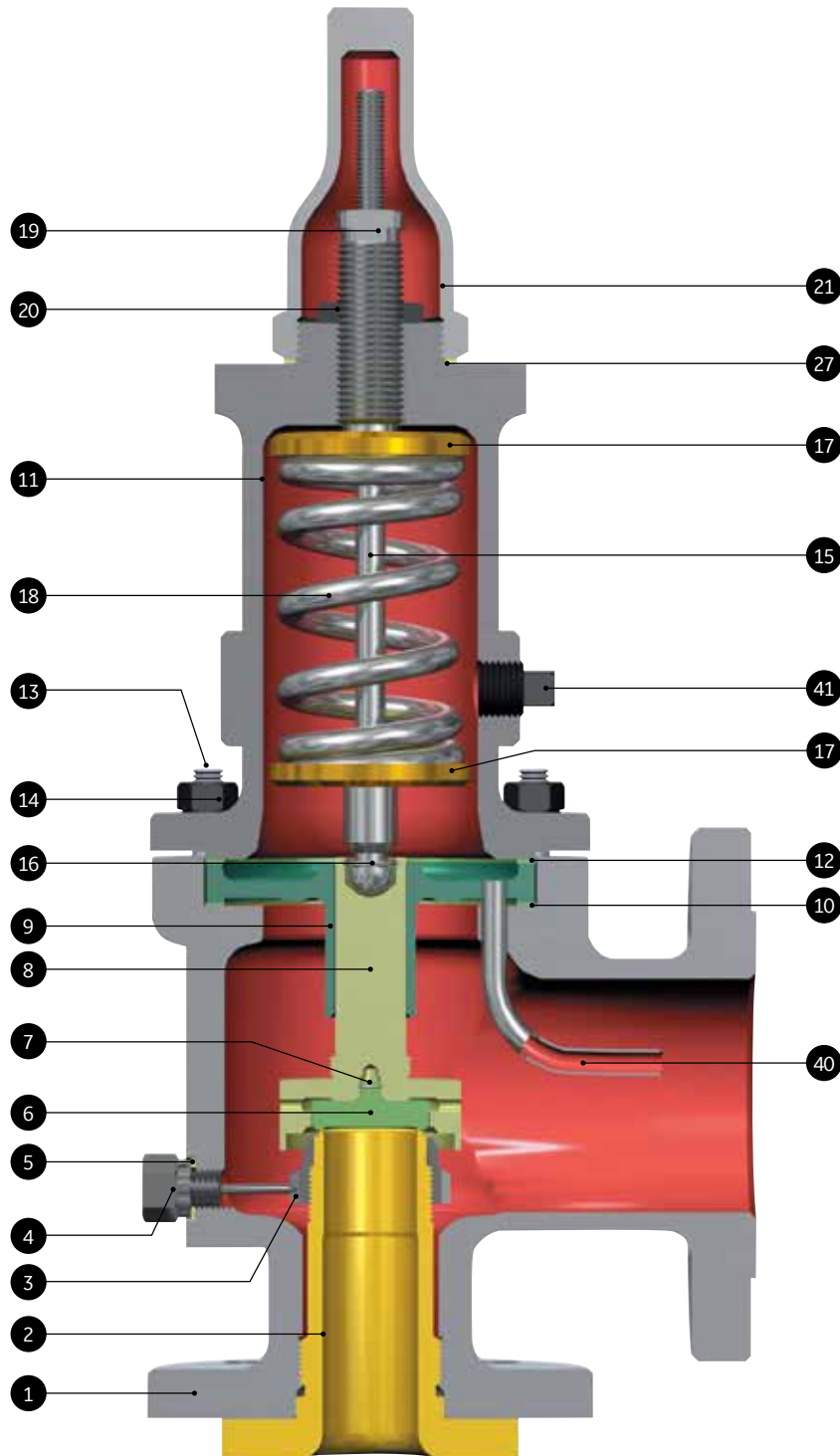

Materials

For Gas, Vapor and Liquid Service 1900 Series (Conventional)

SRV 1900 (Conventional) D-U Orifices			SRV 1900 (Conventional) V and W Orifices		
Part No.	Nomenclature	Conventional (Standard) Valve Material (-00)	Part No.	Nomenclature	Conventional (Standard) Valve Material (-00)
1	Base		3	Adjusting Ring	410 Stainless Steel
	(1905-1918)	ASME SA216 WCC Carbon Steel	8	Disc Holder	
	(1920-1928)	ASME SA217 WC6 Alloy Steel		(1905-1910)	316 Stainless Steel
1A	Base Plug			(1920)	316 Stainless Steel (Boronized)
	(1905-1918)	Carbon Steel	9	Guide	
	(1920-1928)	316 Stainless Steel		(1905-1910)	410 Stainless Steel
2	Nozzle	316 Stainless Steel		(1920)	316 Stainless Steel (Boronized)
3	Adjusting Ring	316 Stainless Steel	36	Drop Lever	Carbon Steel
4	Adjusting Ring Pin	316 Stainless Steel	48	Guide Rings (Not Shown)	Teflon
5	Adjusting Ring Pin Gasket	Soft Iron	49	Disc Retainer Screw (Not Shown)	316 Stainless Steel
6	Disc		50	Retainer Screw Locknut (Not Shown)	316 Stainless Steel
	Solid Metal Flat Seat	316 Stainless Steel	51	Compression Screw (Not Shown)	616 Stainless Steel
	Thermodisc	616 Stainless Steel	52	Compression Screw Locknut Gasket (Not Shown)	Soft Iron
7	Disc Retainer	Inconel X-750	53	Spring Plunger (Not Shown)	616 Stainless Steel
8	Disc Holder	316 Stainless Steel		Plunger Rings (Not Shown)	Teflon
9	Guide	316 Stainless Steel			
10	Guide Gasket	Soft Iron			
11	Bonnet	ASME SA216 WCC Carbon Steel			
12	Bonnet Gasket	Soft Iron			
13	Base Stud	ASME SA193 B7 Alloy Steel			
14	Stud Nut	ASME SA194 2H Carbon Steel			
15	Spindle	410 Stainless Steel			
16	Spindle Retainer	Inconel X-750			
17	Spring Washer	Carbon Steel			
18	Spring				
	(-450° to -76°F)	316 Stainless Steel			
	(-75° to 800°F)	Alloy Steel			
	(801° to 1000°F)	Tungsten Steel or Inconel X-750			
19	Adjusting Screw	416 Stainless Steel			
20	Adjusting Screw Nut	416 Stainless Steel			
21	Screwed Cap	Carbon Steel			
22	Bolted Cap	Carbon Steel			
23	Packed Cap	Carbon Steel			
24	Plain Cap	Malleable Iron			
25	Cap Bolt	Carbon Steel			
26	Cap Set Screw	Carbon Steel			
27	Cap Gasket	Soft Iron			
28	Release Nut	Carbon Steel			
29	Release Locknut	Carbon Steel			
30	Lever (Packed and Plain)	Malleable Iron			
31	Lifting Fork	Malleable Iron			
32	Lever Shaft	410/416 Stainless Steel			
33	Packing	316 Stainless Steel ¹			
34	Packing Nut	410/416 Stainless Steel			
35	Top Lever	Malleable Iron			
36	Drop Lever	Malleable Iron			
37	Gag	Carbon Steel			
38	Sealing Plug	Carbon Steel			
39	Sealing Plug Gasket	Soft Iron			
40	Eductor Tube	316 Stainless Steel			
41	Bonnet Plug	Carbon Steel			
42	Limit Washer (D-2 and E-2)	316 Stainless Steel			

Note:

1. With Flexible Graphite Fillers (Spiral Wound).

Materials

Conventional Safety Relief Valve 1900-30 Series Balanced (Bellows Type)

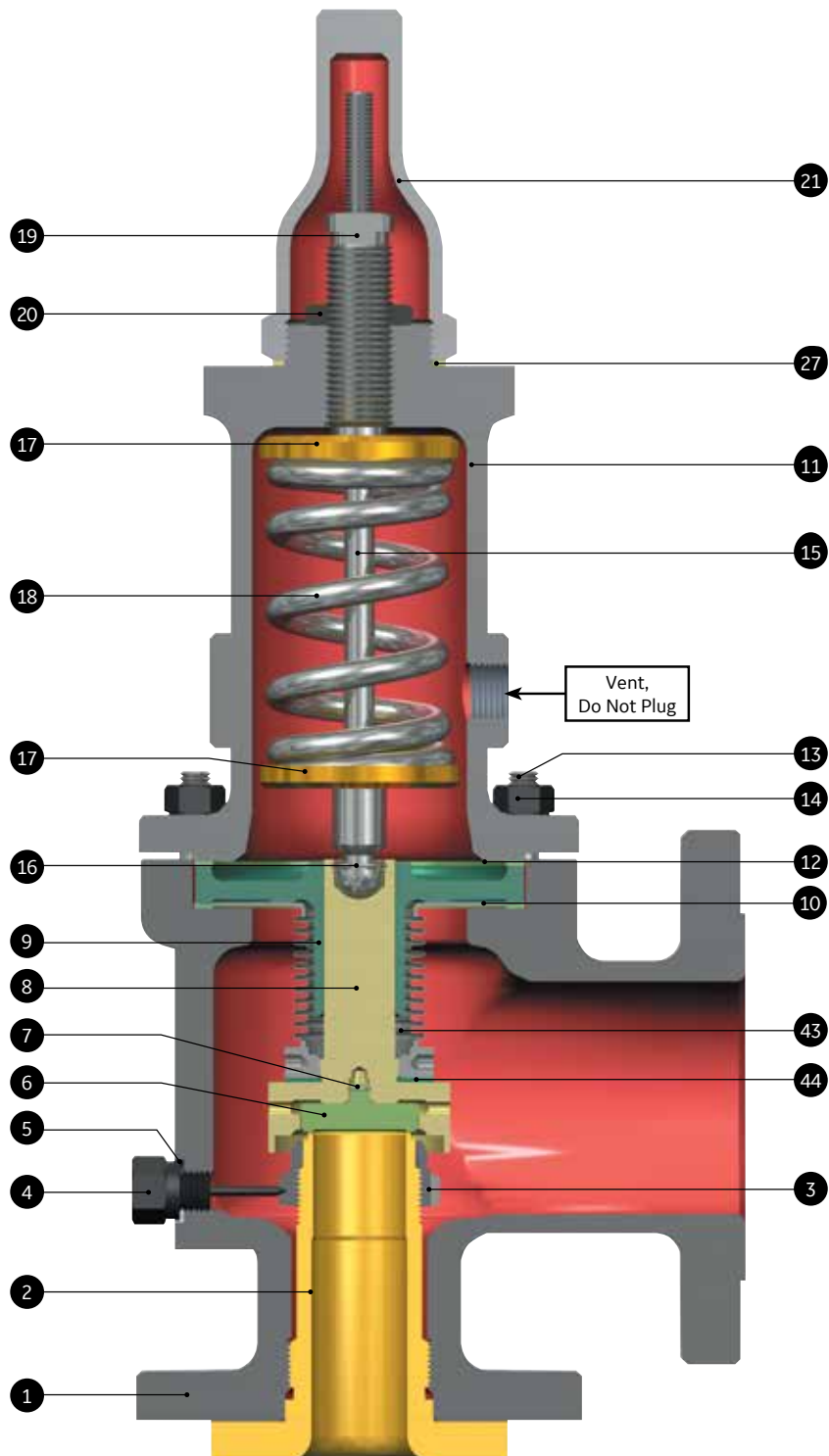

Materials

For Gas, Vapor, and Liquid Service 1900-30 Series (Balanced Bellows)

SRV 1900 Bellows (D - U Orifices)			SRV 1900 Bellows (V and W Orifices)		
Part No.	Nomenclature	Bellows Valve Material (-30)	Part No.	Nomenclature	Bellows Valve Material (-30)
1	Base		3	Adjusting Ring	410 Stainless Steel
	(1905-1918)	ASME SA216 WCC Carbon Steel	8	Disc Holder	
	(1920-1928)	ASME SA217 WC6 Alloy Steel		(1905-1910)	316 Stainless Steel
1A	Base Plug			(1920)	316 Stainless Steel (Boronized)
	(1905-1918)	Carbon Steel	9	Guide	
	(1920-1928)	316 Stainless Steel		(1905-1910)	410 Stainless Steel
2	Nozzle	316 Stainless Steel		(1920)	316 Stainless Steel (Boronized)
3	Adjusting Ring	316 Stainless Steel	20	Compression Screw Nut	416 Stainless Steel
4	Adjusting Ring Pin	316 Stainless Steel	36	Drop Lever	Carbon Steel
5	Adjusting Ring Pin Gasket	Soft Iron	45	Bellows Bolts (Not Shown)	ASME SA193 B7 Alloy Steel
6	Disc		46	Bellows Bolts Lock Washers (Not Shown)	316 Stainless Steel
	Solid Metal Flat Seat	316 Stainless Steel	47	Overlift Restrictor (Not Shown)	410 Stainless Steel
	Thermodisc	616 Stainless Steel	48	Guide Rings (Not Shown)	Teflon
7	Disc Retainer	Inconel X-750	49	Disc Retainer Screw (Not Shown)	316 Stainless Steel
8	Disc Holder	316 Stainless Steel	50	Retainer Screw Locknut (Not Shown)	316 Stainless Steel
9	Guide	316 Stainless Steel	51	Compression Screw (Not Shown)	616 Stainless Steel
10	Guide Gasket	Soft Iron	52	Compression Screw Locknut Gasket (Not Shown)	Soft Iron
11	Bonnet	ASME SA216 WCC Carbon Steel	53	Spring Plunger (Not Shown)	616 Stainless Steel
12	Bonnet Gasket	Soft Iron		Plunger Rings (Not Shown)	Teflon
13	Base Stud	ASME SA193 B7 Alloy Steel			
14	Stud Nut	ASME SA194 2H Carbon Steel			
15	Spindle	410 Stainless Steel			
16	Spindle Retainer	Inconel X-750			
17	Spring Washer	Carbon Steel			
18	Spring				
	(-450° to -76°F)	316 Stainless Steel			
	(-75° to 800°F)	Alloy Steel			
	(801° to 1000°F)	Tungsten Steel or Inconel X-750			
19	Adjusting Screw	416 Stainless Steel			
20	Adjusting Screw Nut	416 Stainless Steel			
21	Screwed Cap	Carbon Steel			
22	Bolted Cap	Carbon Steel			
23	Packed Cap	Carbon Steel			
24	Plain Cap	Malleable Iron			
25	Cap Bolt	Carbon Steel			
26	Cap Set Screw	Carbon Steel			
27	Cap Gasket	Soft Iron			
28	Release Nut	Carbon Steel			
29	Release Locknut	Carbon Steel			
30	Lever (Packed and Plain)	Malleable Iron			
31	Lifting Fork	Malleable Iron			
32	Lever Shaft	410/416 Stainless Steel			
33	Packing	316 Stainless Steel ¹			
34	Packing Nut	410/416 Stainless Steel			
35	Top Lever	Malleable Iron			
36	Drop Lever	Malleable Iron			
37	Gag	Carbon Steel			
38	Sealing Plug	Carbon Steel			
39	Sealing Plug Gasket	Soft Iron			
42	Limit Washer (D-2 and E-2)	316 Stainless Steel			
43	Bellows	Inconel 625 LCF			
43	Bellows Nut	316L Stainless Steel			
43	Bellows Flange	316L Stainless Steel			
44	Bellows Gasket	Soft Iron			

Note:

1. With Flexible Graphite Fillers (Spiral Wound).

Materials

Conventional Safety Relief Valve 1900-35 Series (Balanced Piston)

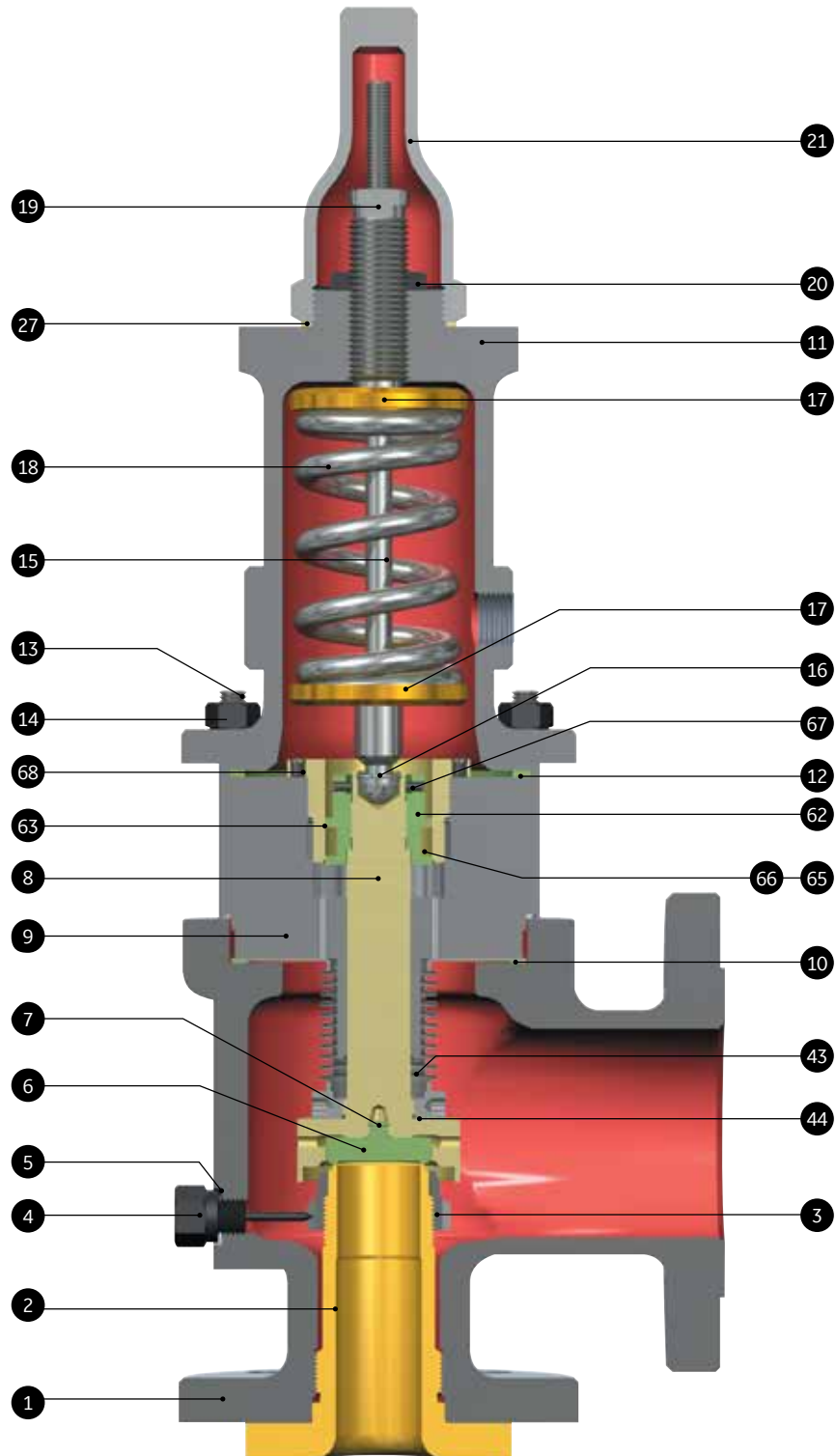

Materials

For Gas, Vapor, and Liquid Service 1900-35 Series (Balanced Piston)

SRV 1900 Balanced Bellows		
Part No.	Nomenclature	Balanced Piston Valve Material (-35) ¹
1	Base	
	(1905-1918)	ASME SA216 WCC Carbon Steel
	(1920-1928)	ASME SA217 WC6 Alloy Steel
1A	Base Plug	
	(1905-1918)	Carbon Steel
	(1920-1928)	316 Stainless Steel
2	Nozzle	316 Stainless Steel
3	Adjusting Ring	316 Stainless Steel
4	Adjusting Ring Pin	316 Stainless Steel
5	Adjusting Ring Pin Gasket	Soft Iron
6	Disc	
	Solid Metal Flat Seat	316 Stainless Steel
	Thermodisc	616 Stainless Steel
7	Disc Retainer	Inconel X-750
8	Disc Holder	316 Stainless Steel
9	Guide	316 Stainless Steel
10	Guide Gasket	Soft Iron
11	Bonnet	ASME SA216 WCC Carbon Steel
12	Bonnet Gasket	Soft Iron
13	Base Stud	ASME SA193 B7 Alloy Steel
14	Stud Nut	ASME SA194 2H Carbon Steel
15	Spindle	410 Stainless Steel
16	Spindle Retainer	Inconel X-750
17	Spring Washer	Carbon Steel
18	Spring	
	(-450° to -76°F)	316 Stainless Steel
	(-75° to 800°F)	Alloy Steel
	(801° to 1000°F)	Tungsten Steel or Inconel X-750
19	Adjusting Screw	416 Stainless Steel
20	Adjusting Screw Nut	416 Stainless Steel
21	Screwed Cap	Carbon Steel
22	Bolted Cap	Carbon Steel
23	Packed Cap	Carbon Steel

SRV 1900 Balanced Bellows		
Part No.	Nomenclature	Balanced Piston Valve Material (-35) ¹
24	Plain Cap	Malleable Iron
25	Cap Bolt	Carbon Steel
26	Cap Set Screw	Carbon Steel
27	Cap Gasket	Soft Iron
28	Release Nut	Carbon Steel
29	Release Locknut	Carbon Steel
30	Lever	Malleable Iron
31	Lifting Fork	Malleable Iron
32	Lever Shaft	410/416 Stainless Steel
33	Packing	316 Stainless Steel ²
34	Packing Nut	410/416 Stainless Steel
35	Top Lever	Malleable Iron
36	Drop Lever	Malleable Iron
37	Gag	Carbon Steel
38	Sealing Plug	Carbon Steel
39	Sealing Plug Gasket	Soft Iron
42	Limit Washer (D-2 and E-2)	316 Stainless Steel
43	Bellows	Inconel 625 LCF
43	Bellows Nut	316L Stainless Steel
43	Bellows Flange	316L Stainless Steel
44	Bellows Gasket	Soft Iron
62	Piston	304 Stainless Steel
63	Piston Guide	316 Stainless Steel
64	Piston Retainer Ring (D-F only) (Not Shown)	Inconel X-750
65	Seal Ring	Graphitar Grade 67
66	Seal Ring Expander	410 Stainless Steel
67	Piston Lock Screw	18-8 Stainless Steel
68	Piston Guide lock Screw	18-8 Stainless Steel
69	Piston Plate (D-F only) (Not Shown)	316 Stainless Steel

Notes:

1. Other material variations are available. Balanced piston components will be per the bellows "-30" type, except in "X3" and "X4" variations. (S3, S4, etc.). In these cases, the materials for the piston, lock screws, seal ring expander, and piston guide may be changed. The Seal Ring will remain as Graphitar Grade 67.
2. With Flexible Graphite Fillers (Spiral Wound).

Materials

1900 Soft Seat (DA) Option Safety Relief Valve

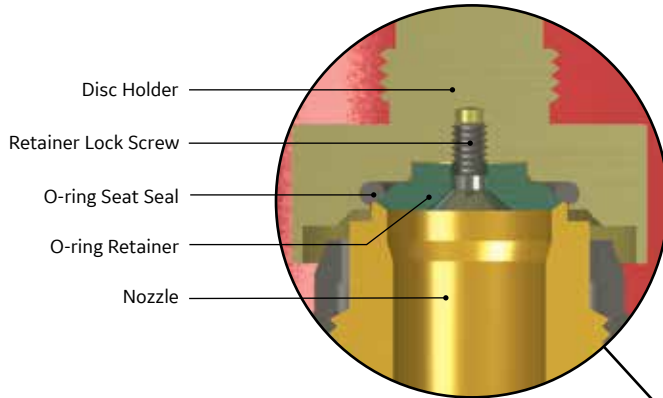

D Thru J Orifice

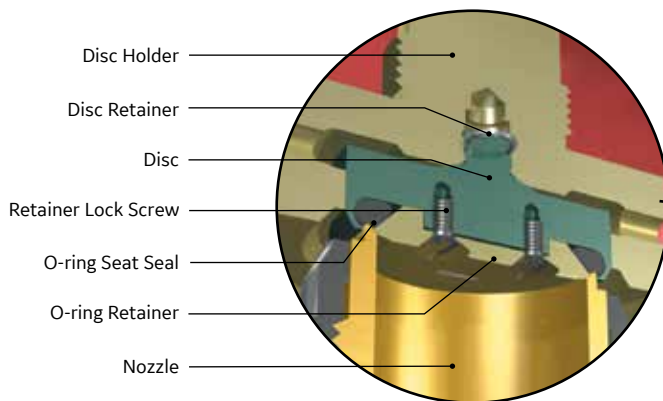

K Thru T Orifice

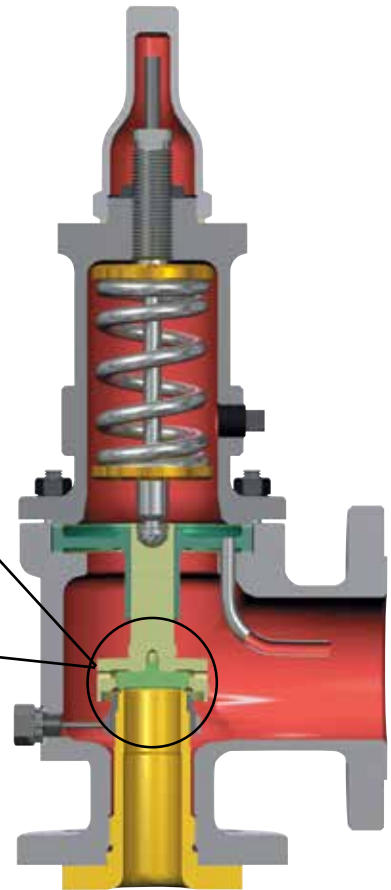

Standard Material for 1900 Soft Seat (DA) Safety Relief Valves	
Part Name	Materials ¹
Disc (K-T Orifice)	316 Stainless Steel
Disc Holder ²	316 Stainless Steel
Bonnet	ASME SA352 LCC CS
Disc Retainer	Inconel X750
O-ring Retainer ³	316 Stainless Steel
Retainer Lock Screw (Not Shown) ³	316 Stainless Steel
O-ring Seat Seal	Select ⁴

Notes:

1. Balance of materials is the same as 1900 standard construction
2. Disc Holder material for D-J orifice, will be Monel for "M" variations and Hastelloy C for "H" variations.
3. O-ring Retainer material will be Monel for "M" variations and Hastelloy C for "H" variations. The retainer lock screw will be Monel with Nylon locking feature in the "M" variations and Hastelloy C with Nylon locking feature in the "H" variations.
4. Refer to pages 1900.41 and 1900.42 for O-ring Selection (Durometer and Temperature Limits). See Technical Information Section for application.

Materials

1900 Steam Trim (TD) Option Safety Relief Valve

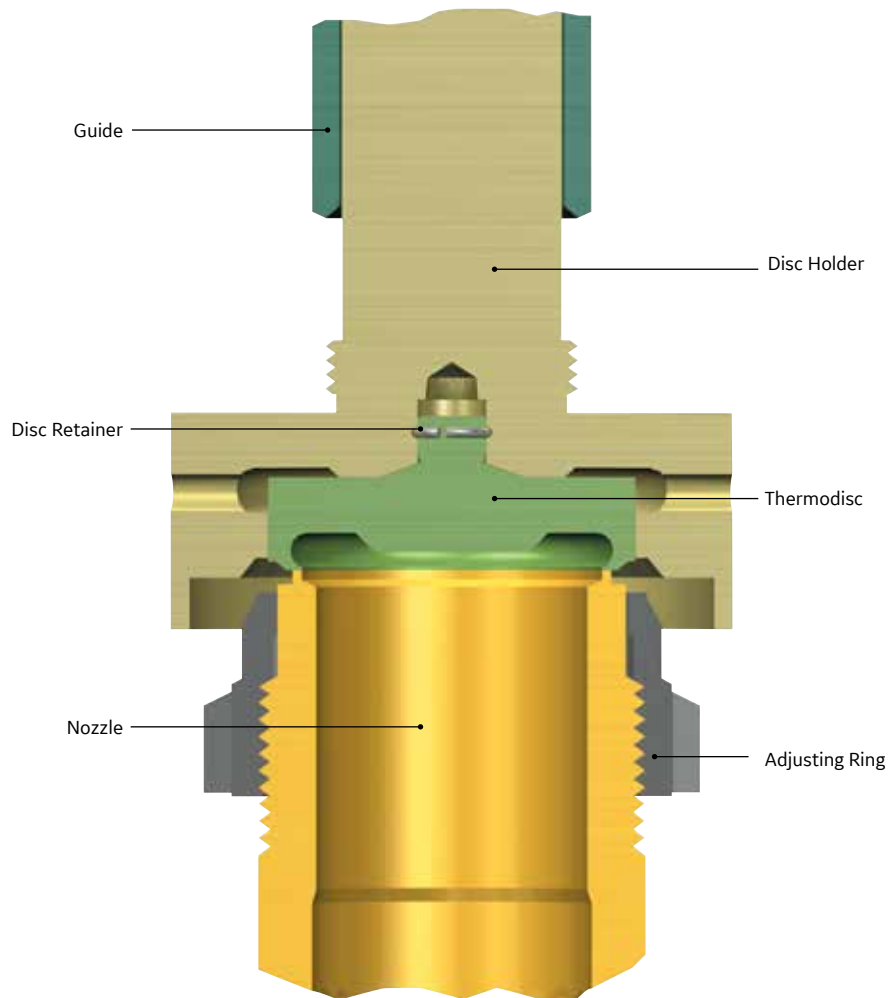

Standard Material for 1900 Steam Trim (TD)
Safety Relief Valves

Part Name	Materials ¹
Nozzle	316 Stainless Steel
Thermodisc	616 Stainless Steel
Disc Retainer	Inconel X750
Disc Holder	316 Stainless Steel
Guide	316 Stainless Steel
Adjusting Ring	316 Stainless Steel

Note:

1. Balance of materials same as 1900 standard construction.

Materials

1900 Liquid Trim (LA) Option Safety Relief Valve

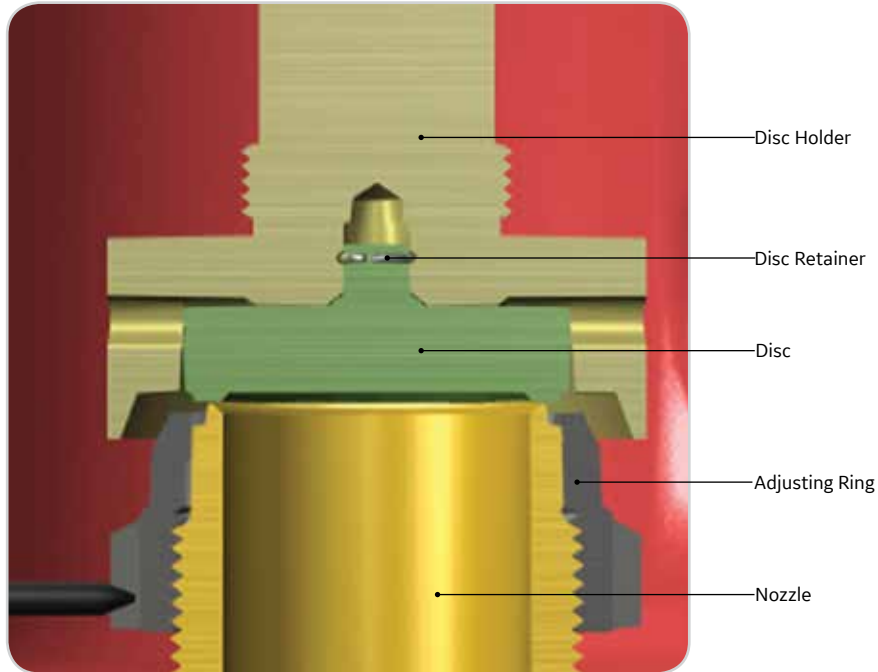

Standard Material for 1900 Liquid Trim (LA) Safety Relief Valves	
Part Name	Materials ¹
Nozzle	316 Stainless Steel
Disc	316 Stainless Steel
Disc Retainer	Inconel X750
Disc Holder	316 Stainless Steel
Guide	316 Stainless Steel
Adjusting Ring	316 Stainless Steel

Note:

1. Balance of materials same as 1900 standard construction.

Materials

1900 Special Material and Service Options

The 1900 Flanged Series offers various material options to satisfy customer needs and API standards. The most common options are listed in this section.

These material options are not the only available options however. Ask BHGE for options not listed here.

Specify the material construction classification using the construction variations such as: S2, H4, etc.

Options included are:	Page Number
• Sour Gas Service (N1 and N2)	29
• Hydrofluoric Acid Service (HA)	31
• Stainless Steel (S2, S3 and S4)	32
• Alloy 20 (A1, A2, A3 and A4)	34
• Monel (M1, M1½(MB), M2, M3 and M4)	35
• Hastelloy C (H1, H2, H3 and H4)	36
• Duplex (D1, D2, D3 and D4)	37
• Low Temperature - Process Fluid (L1, L2, and L3) (For media temperatures to -450°F or -268°C)	39
• Low Temperature - Ambient (C1 and C2) (For ambient temperatures to -50°F or -45.6°C)	40
• High Temperature (T1 and T2) (For media temperatures to 1500°F or 816°C)	41
• Lethal Service	42
• O-ring Selection	43

Many other special options not necessarily of a material nature are available. These include, but are not limited to, special facings on connections or special connections. Contact the factory for any special requirements you may have.

Materials

1900 Sour Gas Trims

Standard Material for 1900 Sour Gas Safety Relief Valves				
Component	Construction Variation			
	Conventional Valves		Bellows Valves	
	N1	N2	N1	N2
Base (1905-1918), Bonnet	ASME SA216 WCC CS	ASME SA351 CF8M SS	ASME SA216 WCC CS	ASME SA351 CF8M SS
Base (1920-1928)	ASME SA217 WC6 AS	ASME SA351 CF8M SS	ASME SA217 WC6 AS	ASME SA351 CF8M SS
Base Plug (1905-1918)	Carbon Steel	316 Stainless Steel	Carbon Steel	316 Stainless Steel
Base Plug (1920-1928), Nozzle	316 Stainless Steel	316 Stainless Steel	316 Stainless Steel	316 Stainless Steel
Adjusting Ring, Adjusting Ring Pin	316 Stainless Steel	316 Stainless Steel	316 Stainless Steel	316 Stainless Steel
Adjusting Ring Pin Gasket	Soft Iron	Monel	Soft Iron	Monel
Disc - Solid Metal Flat Seat, Disc Holder	316 Stainless Steel	316 Stainless Steel	316 Stainless Steel	316 Stainless Steel
Disc - Thermodisc, Disc Retainer	Inconel X-750	Inconel X-750	Inconel X-750	Inconel X-750
Guide, Limit Washer (D-2 and E-2)	316 Stainless Steel	316 Stainless Steel	316 Stainless Steel	316 Stainless Steel
Guide Gasket, Bonnet Gasket	Soft Iron	Monel	Soft Iron	Monel
Base Stud	ASME SA193 B7 AS	ASME SA193 B8M SS	ASME SA193 B7 AS	ASME SA193 B8M SS
Stud Nut	ASME SA194 2H CS	ASME SA194 8M SS	ASME SA194 2H CS	ASME SA194 8M SS
Spindle	316 Stainless Steel	316 Stainless Steel	410 Stainless Steel	316 Stainless Steel
Spindle Retainer	Inconel X-750	Inconel X-750	Inconel X-750	Inconel X-750
Spring Washer	316 Stainless Steel	316 Stainless Steel	Carbon Steel	316 Stainless Steel
Spring	Inconel X-750	Inconel X-750	Alloy Steel ⁴	316 Stainless Steel
Adjusting Screw, Adjusting Screw Nut	316 Stainless Steel	316 Stainless Steel	416 Stainless Steel	316 Stainless Steel
Screwed Cap, Bolted Cap, Gag	Carbon Steel	316 Stainless Steel	Carbon Steel	316 Stainless Steel
Packed Cap, Cap Bolt	Carbon Steel	316 Stainless Steel	Carbon Steel	316 Stainless Steel
Plain Cap, Lever, Lifting Fork	Malleable Iron	Malleable Iron	Malleable Iron	Malleable Iron
Cap Set Screw, Sealing Plug	Carbon Steel	Carbon Steel, 316 Stainless Steel	Carbon Steel	Carbon Steel, 316 Stainless Steel
Cap Gasket, Sealing Plug Gasket	Soft Iron	Monel	Soft Iron	Monel
Release Nut, Release Locknut	Carbon Steel	316 Stainless Steel	Carbon Steel	316 Stainless Steel
Lever Shaft, Packing Nut	410/416 Stainless Steel	316 Stainless Steel	410/416 Stainless Steel	316 Stainless Steel
Packing	316 Stainless Steel ⁶	316 Stainless Steel ⁶	316 Stainless Steel ⁶	316 Stainless Steel ⁶
Top Lever, Drop Lever	Malleable Iron	Malleable Iron	Malleable Iron	Malleable Iron
Eductor Tube	316 Stainless Steel	316 Stainless Steel	Not Applicable	Not Applicable
Bonnet Plug	Carbon Steel	316 Stainless Steel	Not Applicable	Not Applicable
Bellows	Not Applicable	Not Applicable	Inconel 625 LCF ⁵	Inconel 625 LCF ⁵
Bellows Nut, Bellows Flange	Not Applicable	Not Applicable	316L Stainless Steel	316L Stainless Steel
Bellows Gasket	Not Applicable	Not Applicable	Soft Iron	Monel

Notes:

1. The materials in red denote variation from standard material construction.
2. Compliance to NACE MR0175 requires media and materials evaluation. Please contact factory sales.
3. N1 and N2 valves are for installations for compliance to NACE MR0103-2015 and prior editions.
4. Spring is Aluminum Metallized.
5. Heat treated.
6. With Flexible Graphite Fillers (Spiral Wound).

Materials

1900 Hydrofluoric Acid (HA) Service

To meet the demanding requirements of extremely corrosive HF Alky service, BHGE has, in conjunction with major designers and users in this industry, developed the 1900 HA variation. Extensive use of Monel Alloy 400, in the stress-relieved condition for critical components, has been utilized for this option.

NACE document 5A171 states, "In practice, occurrence of stress corrosion cracking may either be avoided by complete exclusion of oxygen or may be minimized by

stress-relieving welded or cold formed parts." The HA materials should not be confused with the M1-through-M4 materials used for other corrosive applications.

In addition to the special stress-relieved conditioned Monel 400 materials, a bellows seal and litharged-cured soft seat have been incorporated into this option. Long-term applications have shown excellent results in the most severe, moist, aerated HF Alky service.

Special Materials, Hydrofluoric Acid Service (HA) ^{1 & 2}	
Component	Bellows Valve Material (-30)
Base (1905-1918)	ASME SA216 WCC CS ³
Base Plug (1905-1918)	Carbon Steel
Nozzle	Monel 400 ⁴
Adjusting Ring	Monel 400
Adjusting Ring Pin	Monel 400
Adjusting Ring Pin Gasket	Monel 400
Disc - Solid Metal Flat Seat	Monel 400 ⁴
Disc Retainer	Inconel X-750
Disc Holder	Monel 400 ⁴
Guide	Monel 400
Guide Gasket	Monel 400
Bonnet	ASME SA216 WCC CS
Bonnet Gasket	Monel 400
Base Stud	ASTM F468 Nickel Alloy 500
Stud Nut	ASTM F467 Nickel Alloy 500
Spindle	Monel 400
Spindle Retainer	Inconel X-750
Spring Washer	Carbon Steel
Spring	Carbon Steel (Nickel Plated)
Adjusting Screw	Monel 400
Adjusting Screw Nut	Monel 400
Screwed Cap	Carbon Steel
Bolted Cap	Carbon Steel
Packed Cap	Carbon Steel

Special Materials, Hydrofluoric Acid Service (HA) ^{1 & 2}	
Component	Bellows Valve Material (-30)
Plain Cap	Malleable Iron
Cap Bolt	Carbon Steel
Cap Set Screw	Carbon Steel
Cap Gasket	Monel 400
Release Nut	Carbon Steel
Release Locknut	Carbon Steel
Lever	Malleable Iron
Lifting Fork	Malleable Iron
Lever Shaft	410 Stainless Steel
Packing	316 Stainless Steel ⁵
Packing Nut	410 Stainless Steel
Top Lever	Malleable Iron
Drop Lever	Malleable Iron
Gag	Carbon Steel
Sealing Plug	Carbon Steel
Sealing Plug Gasket	Monel 400
Limit Washer (D-2 and E-2)	Monel 400
Bellows	Monel 400 ⁴
Bellows Nut	Monel 400 ⁴
Bellows Flange	Monel 400 ⁴
Bellows Gasket	Garlock Gylon 35101
O-ring Retainer	Monel 400 ⁴
Retainer Lock Screw	Monel 400 with Nylon Lock Feature
O-ring	Kalrez Spectrum 6375

Notes:

- The materials in red denote variation from standard material construction.
- To specify valves, add material designation to the valve type, 1910L/HA or 1910-30L/HA.
- (Including Supplement S5)
PWHT is required for weld repairs per ASTM A216 paragraph 10, or if C.E. is above 0.40. Carbon equivalent shall be determined per ASTM A216, S11.2. Weld PQR shall include hardness test of PWHT area. Test piece to confirm that weld and weld heat-affected-zone hardnesses are 200 brinell maximum.
- Stress relieved.
- With Flexible Graphite Fillers (Spiral Wound).

Materials

Corrosive Service

Corrosive Service, Stainless Steel Material (D-U Orifice) ^{1 & 2}			
Component	Construction Variation		
	S2	S3	S4
Common Components (-00 and -30)			
Base (1905-1918), Bonnet	ASME SA216 WCC CS	ASME SA351 CF8M SS	ASME SA351 CF8M SS
Base (1920-1928)	ASME SA217 WC6 AS	ASME SA351 CF8M SS	ASME SA351 CF8M SS
Base Plug (1905-1918), Release Nut, Sealing Plug	Carbon Steel	316 Stainless Steel	316 Stainless Steel
Base Plug (1920-1928), Nozzle	316 Stainless Steel	316 Stainless Steel	316 Stainless Steel
Adjusting Ring, Adjusting Ring Pin	316 Stainless Steel	316 Stainless Steel	316 Stainless Steel
Adjusting Ring Pin Gasket, Guide Gasket	Monel	Monel	Monel
Disc - Solid Metal Flat Seat, Disc Holder	316 Stainless Steel	316 Stainless Steel	316 Stainless Steel
Disc - Thermodisc	616 Stainless Steel	616 Stainless Steel	616 Stainless Steel
Disc Retainer, Spindle Retainer	Inconel X-750	Inconel X-750	Inconel X-750
Guide, Limit Washer (D-2 and E-2)	316 Stainless Steel	316 Stainless Steel	316 Stainless Steel
Base Stud	ASME SA193 B7 AS	ASME SA193 B8M SS	ASME SA193 B8M SS
Stud Nut	ASME SA194 2H CS	ASME SA194 8M SS	ASME SA194 8M SS
Spring Washer, Release Locknut	Carbon Steel	Carbon Steel	316 Stainless Steel
Spring (-20° to 800°F)	Alloy Steel	Alloy Steel	316 Stainless Steel
Spring (801° to 1000°F)	Tungsten Steel ³	Tungsten Steel ³	316 Stainless Steel
Screwed Cap, Bolted Cap, Packed Cap	Carbon Steel	316 Stainless Steel	316 Stainless Steel
Plain Cap, Lifting Fork	Malleable Iron	316 Stainless Steel	316 Stainless Steel
Cap Bolt	Carbon Steel	ASME SA193 B8M SS	ASME SA193 B8M SS
Cap Set Screw	Carbon Steel	B8M Stainless Steel	B8M Stainless Steel
Cap Gasket, Sealing Plug Gasket	Manel	Manel	Manel
Lever, Top Lever, Drop Lever	Malleable Iron	Malleable Iron	Malleable Iron
Lever Shaft, Packing Nut	410/416 Stainless Steel	316 Stainless Steel	316 Stainless Steel
Packing	316 Stainless Steel ⁴	316 Stainless Steel ⁴	316 Stainless Steel ⁴
Gag	Carbon Steel	Carbon Steel	Carbon Steel
Conventional (Standard) Valve Components (-00)			
Bonnet Gasket	Monel	Monel	Monel
Spindle, Adjusting Screw	316 Stainless Steel	316 Stainless Steel	316 Stainless Steel
Adjusting Screw Nut, Eductor Tube	316 Stainless Steel	316 Stainless Steel	316 Stainless Steel
Bonnet Plug	Carbon Steel	316 Stainless Steel	316 Stainless Steel
Bellows Valve Components (-30)			
Bonnet Gasket	Soft Iron	Monel	Monel
Spindle, Adjusting Screw	410 Stainless Steel	316 Stainless Steel	316 Stainless Steel
Adjusting Screw Nut	416 Stainless Steel	316 Stainless Steel	316 Stainless Steel
Bellows	Inconel 625 LCF	Inconel 625 LCF	Inconel 625 LCF
Bellows Nut, Bellows Flange	316L Stainless Steel	316L Stainless Steel	316L Stainless Steel
Bellows Gasket	Monel	Monel	Monel

Notes:

1. The materials in red denote variation from standard material construction.
2. To specify valves, add material designation to the valve type, 1910L/S3 or 1910-30L/S3.
3. or Inconel X-750
4. With Flexible Graphite Fillers (Spiral Wound).

Materials

Corrosive Service

Corrosive Service, Stainless Steel Material (V and W Orifice) ^{1 & 2}			
Component	Construction Variation		
	S2	S3	S4
Common Components (-00 and -30)			
Base(1905-1910)	ASME SA216 WCC CS	ASME SA351 CF8M SS	ASME SA351 CF8M SS
Base(1920-1928)	ASME SA217 WC6 AS	ASME SA351 CF8M SS	ASME SA351 CF8M SS
Base Plug (1905-1910), Screwed Cap, Bolted Cap	Carbon Steel	316 Stainless Steel	316 Stainless Steel
Packed Cap, Cap Set Screw, Release Nut	Carbon Steel	316 Stainless Steel	316 Stainless Steel
Release Locknut, Sealing Plug	Carbon Steel	316 Stainless Steel	316 Stainless Steel
Base Plug (1920-1928), Nozzle, Adjusting Ring	316 Stainless Steel	316 Stainless Steel	316 Stainless Steel
Adjusting Ring Pin, Disc - Solid Metal Flat Seat	316 Stainless Steel	316 Stainless Steel	316 Stainless Steel
Disc Retainer Screw, Retainer Screw Locknut	316 Stainless Steel	316 Stainless Steel	316 Stainless Steel
Disc Holder - (1905-1910), Spindle	316 Stainless Steel	316 Stainless Steel	316 Stainless Steel
Compression Screw Nut, Guide (1905-1910)	316 Stainless Steel	316 Stainless Steel	316 Stainless Steel
Adjusting Ring Pin Gasket, Guide Gasket, Cap Gasket	Monel	Monel	Monel
Compression Screw Locknut Gasket, Sealing Plug Gasket	Monel	Monel	Monel
Disc - Thermodisc, Spring Plunger, Compression Screw	616 Stainless Steel	616 Stainless Steel	616 Stainless Steel
Disc Holder (1920-1928), Guide (1920-1928)	316 Stainless Steel (Boronized)	316 Stainless Steel (Boronized)	316 Stainless Steel (Boronized)
Bonnet	ASME SA216 WCC CS	ASME SA351 CF8M SS	ASME SA351 CF8M SS
Base Stud	ASME SA193 B7 Alloy Steel	ASME SA193 B8M Alloy Steel	ASME SA193 B8M Alloy Steel
Stud Nut	ASME SA194 2H Carbon Steel	ASME SA194 8M Carbon Steel	ASME SA194 8M Carbon Steel
Spring Washer, Drop Lever, Gag	Carbon Steel	Carbon Steel	Carbon Steel
Spring (-20° to 800°F)	Alloy Steel	Alloy Steel	316 Stainless Steel
Spring (801° to 1000°F)	Tungsten Steel or Inconel X-750	Tungsten Steel or Inconel X-750	316 Stainless Steel
Plain Cap	Malleable Iron	316 Stainless Steel	316 Stainless Steel
Cap Bolt	Carbon Steel	ASME SA193 B8M Alloy Steel	ASME SA193 B8M Alloy Steel
Lever, Top Lever	Malleable Iron	Malleable Iron	Malleable Iron
Lifting Fork	Malleable Iron	316 Stainless Steel	316 Stainless Steel
Lever Shaft	410/416 Stainless Steel	316 Stainless Steel	316 Stainless Steel
Packing	316 Stainless Steel ³	316 Stainless Steel ³	316 Stainless Steel ³
Packing Nut	410/416 Stainless Steel	316 Stainless Steel	316 Stainless Steel
Guide Rings (1905-1910), Plunger Rings (Not Shown)	Teflon	Teflon	Teflon
Conventional (Standard) Valve Components (-00)			
Bonnet Gasket	Monel	Monel	Monel
Eductor Tube	316 Stainless Steel	316 Stainless Steel	316 Stainless Steel
Bonnet Plug	Carbon Steel	316 Stainless Steel	316 Stainless Steel
Bellows Valve Components (-30)			
Bonnet Gasket	Soft Iron	Monel	Monel
Limit Washer	410 Stainless Steel	316 Stainless Steel	316 Stainless Steel
Bellows	Inconel 625 LCF	Inconel 625 LCF	Inconel 625 LCF
Bellows Nut , Bellows Flange	316L Stainless Steel	316L Stainless Steel	316L Stainless Steel
Bellows Gasket	Monel	Monel	Monel
Bellows Bolts	ASME SA193 B7 Alloy Steel	ASME SA193 B8M Alloy Steel	ASME SA193 B8M Alloy Steel
Bellows Bolts Lock Washers	316 Stainless Steel	316 Stainless Steel	316 Stainless Steel
Overlift Restrictor	410 Stainless Steel	410 Stainless Steel	410 Stainless Steel

Notes:

1. The materials in red denote variation from standard material construction.
2. To specify valves, add material designation to the valve type, 1910L/S3 or 1910-30L/S3.
3. With Flexible Graphite Fillers (Spiral Wound).

Materials

Corrosive Service

Corrosive Service, Alloy 20 Material ^{1 & 2}				
Component	Construction Variation			
	A1	A2	A3	A4
Common Components (-00 and -30)				
Base (1905-1918)	ASME SA216 WCC CS	ASME SA216 WCC CS	ASME SA351 CN7M AS	ASME SA351 CN7M AS
Base (1920-1928)	ASME SA217 WC6 AS	ASME SA217 WC6 AS	ASME SA351 CN7M AS	ASME SA351 CN7M AS
Base Plug (1905-1918)	Carbon Steel	Carbon Steel	Alloy 20 ³	Alloy 20
Base Plug (1920-1928)	316 Stainless Steel	316 Stainless Steel	Alloy 20	Alloy 20
Nozzle, Disc - Solid Metal Flat Seat	Alloy 20	Alloy 20	Alloy 20	Alloy 20
Adjusting Ring, Adjusting Ring Pin	316 Stainless Steel	Alloy 20	Alloy 20	Alloy 20
Adjusting Ring Pin Gasket	Soft Iron	Monel	Monel	Monel
Disc - Thermosdisc, Disc Retainer	Inconel X-750	Inconel X-750	Inconel X-750	Inconel X-750
Disc Holder	316 Stainless Steel	Alloy 20	Alloy 20	Alloy 20
Guide Gasket	Soft Iron	Monel	Monel	Monel
Bonnet	ASME SA216 WCC CS	ASME SA216 WCC CS	ASME SA351 CN7M AS	ASME SA351 CN7M AS
Base Stud	ASME SA193 B7 AS	ASME SA193 B7 AS	Alloy 20	Alloy 20
Stud Nut	ASME SA194 2H CS	ASME SA194 2H CS	Alloy 20	Alloy 20
Spindle Retainer	Inconel X-750	Inconel X-750	Inconel X-750	Inconel X-750
Spring Washer	Carbon Steel	Carbon Steel	Carbon Steel	Alloy 20
Spring (-20° to 800°F)	Alloy Steel	Alloy Steel	Alloy Steel	Alloy 20
Spring (801° to 1000°F)	Tungsten Steel ⁴	Tungsten Steel ⁴	Tungsten Steel ⁴	Alloy 20
Packed Cap	Carbon Steel	Carbon Steel	Alloy 20	Alloy 20
Plain Cap	Malleable Iron	Malleable Iron	Not Applicable	Not Applicable
Cap Bolt, Sealing Plug	Carbon Steel	Carbon Steel	Alloy 20	Alloy 20
Cap Set Screw	Carbon Steel	Carbon Steel	Not Applicable	Not Applicable
Cap Gasket	Soft Iron	Monel	Monel	Monel
Release Nut, Release Locknut	Carbon Steel	Carbon Steel	Carbon Steel	Carbon Steel
Lever, Lifting Fork	Malleable Iron	Malleable Iron	Malleable Iron	Malleable Iron
Lever Shaft	410/416 Stainless Steel	410/416 Stainless Steel	410/416 Stainless Steel	410/416 Stainless Steel
Packing	316 Stainless Steel ⁵	316 Stainless Steel ⁵	316 Stainless Steel ⁵	316 Stainless Steel ⁵
Packing Nut	410/416 Stainless Steel	410/416 Stainless Steel	410/416 Stainless Steel	410/416 Stainless Steel
Top Lever, Drop Lever	Malleable Iron	Malleable Iron	Not Applicable	Not Applicable
Gag	Carbon Steel	Carbon Steel	Carbon Steel	Carbon Steel
Sealing Plug Gasket	Soft Iron	Monel	Monel	Monel
Conventional (Standard) Valve Components (-00)				
Guide	316 Stainless Steel	Alloy 20	Alloy 20	Alloy 20
Bonnet Gasket	Soft Iron	Monel	Monel	Monel
Spindle	410 Stainless Steel	Alloy 20	Alloy 20	Alloy 20
Adjusting Screw, Adjusting Screw Nut	416 Stainless Steel	Alloy 20	Alloy 20	Alloy 20
Screwed Cap, Bolted Cap, Bonnet Plug	Carbon Steel	Carbon Steel	Alloy 20	Alloy 20
Eductor Tube	316 Stainless Steel	316 Stainless Steel	Alloy 20	Alloy 20
Limit Washer (D-2 and E-2)	316 Stainless Steel	Alloy 20	Alloy 20	Alloy 20
Bellows Valve Components (-30)				
Guide	316 Stainless Steel	316 Stainless Steel	Alloy 20	Alloy 20
Bonnet Gasket	Soft Iron	Soft Iron	Monel	Monel
Spindle	410 Stainless Steel	410 Stainless Steel	Alloy 20	Alloy 20
Adjusting Screw, Adjusting Screw Nut	416 Stainless Steel	416 Stainless Steel	Alloy 20	Alloy 20
Screwed Cap, Bolted Cap	Carbon Steel	Carbon Steel	Carbon Steel	Alloy 20
Limit Washer (D-2 and E-2)	316 Stainless Steel	Alloy 20	Alloy 20	Alloy 20
Bellows	Inconel 625 LCF	Alloy 20	Alloy 20	Alloy 20
Bellows Nut, Bellows Flange	316L Stainless Steel	Alloy 20	Alloy 20	Alloy 20
Bellows Gasket	Soft Iron	Monel	Monel	Monel

Notes:

- The materials in red denote variation from standard material construction.
- To specify valves, add material designation to the valve type, 1910L/A3 or 1910-30L/A3.
- Alloy 20 - ASTM B473 UNS N08020.
- or Inconel X-750.
- With Flexible Graphite Fillers (Spiral Wound).

Materials

Corrosive Service

Corrosive Service, Monel Material ^{1 & 2}					
Component	Construction Variation				
	M1	MB (M 1½)	M2	M3	M4
Common Components (-00 and -30)					
Base (1905-1918)	ASME SA216 WCC CS	ASME SA216 WCC CS	ASME SA216 WCC CS	ASME SA494 M35-1 NCA ³	ASME SA494 M35-1 NCA ³
Base (1920-1928)	ASME SA217 WC6 AS	ASME SA217 WC6 AS	ASME SA217 WC6 AS	ASME SA494 M35-1 NCA ³	ASME SA494 M35-1 NCA ³
Base Plug (1905-1918)	Carbon Steel	Carbon Steel	Carbon Steel	Monel	Monel
Base Plug (1920-1928)	316 Stainless Steel	316 Stainless Steel	316 Stainless Steel	Monel	Monel
Nozzle	Monel	Monel	Monel	Monel	Monel
Adjusting Ring, Adjusting Ring Pin	316 Stainless Steel	Monel	Monel	Monel	Monel
Adjusting Ring Pin Gasket	Soft Iron	Monel	Monel	Monel	Monel
Disc - Solid Metal Flat Seat	Monel	Monel	Monel	Monel	Monel
Disc - Thermosdisc, Disc Retainer	Inconel X-750	Inconel X-750	Inconel X-750	Inconel X-750	Inconel X-750
Disc Holder	316 Stainless Steel	Monel	Monel	Monel	Monel
Guide	316 Stainless Steel	316 Stainless Steel	Monel	Monel	Monel
Guide Gasket	Soft Iron	Monel	Monel	Monel	Monel
Bonnet	ASME SA216 WCC CS	ASME SA216 WCC CS	ASME SA216 WCC CS	ASME SA494 M35-1 NCA ³	ASME SA494 M35-1 NCA ³
Base Stud	ASME SA193 B7 AS	ASME SA193 B7 AS	ASME SA193 B7 AS	Monel K500	Monel K500
Stud Nut	ASME SA194 2H CS	ASME SA194 2H CS	ASME SA194 2H CS	Monel K500	Monel K500
Spindle Retainer	Inconel X-750	Inconel X-750	Inconel X-750	Inconel X-750	Inconel X-750
Spring Washer	Carbon Steel	Carbon Steel	Carbon Steel	Carbon Steel	Monel
Spring (-450° to -21°F)	Not Applicable	Not Applicable	Not Applicable	316 Stainless Steel	Inconel X-750
Spring (-20° to 800°F)	Alloy Steel	Alloy Steel	Alloy Steel	Alloy Steel	Not Applicable
Spring (801° to 1000°F)	Tungsten Steel ⁴	Tungsten Steel ⁴	Tungsten Steel ⁴	Not Applicable	Not Applicable
Adjusting Screw, Adjusting Screw Nut	416 Stainless Steel	416 Stainless Steel	Monel	Monel	Monel
Screwed Cap, Bolted Cap	Carbon Steel	Carbon Steel	Carbon Steel	Monel	Monel
Packed Cap, Sealing Plug	Carbon Steel	Carbon Steel	Carbon Steel	Monel	Monel
Plain Cap	Malleable Iron	Malleable Iron	Malleable Iron	Not Applicable	Not Applicable
Cap Bolt	Carbon Steel	Carbon Steel	Carbon Steel	Monel K500	Monel K500
Cap Set Screw	Carbon Steel	Carbon Steel	Carbon Steel	Not Applicable	Not Applicable
Cap Gasket	Soft Iron	Monel	Monel	Monel	Monel
Release Nut, Release Locknut	Carbon Steel	Carbon Steel	Carbon Steel	Monel	Monel
Lever, Lifting Fork	Malleable Iron	Malleable Iron	Malleable Iron	Malleable Iron ⁵	Malleable Iron ⁵
Lever Shaft, Packing Nut	410/416 Stainless Steel	410/416 Stainless Steel	410/416 Stainless Steel	410/416 Stainless Steel	410/416 Stainless Steel
Packing	316 Stainless Steel ⁶	316 Stainless Steel ⁶	316 Stainless Steel ⁶	316 Stainless Steel ⁶	316 Stainless Steel ⁶
Top Lever, Drop Lever	Malleable Iron	Malleable Iron	Malleable Iron	Not Applicable	Not Applicable
Gag	Carbon Steel	Carbon Steel	Carbon Steel	Carbon Steel	Carbon Steel
Sealing Plug Gasket	Soft Iron	Monel	Monel	Monel	Monel
Limit Washer (D-2 and E-2)	316 Stainless Steel	Monel	Monel	Monel	Monel
Conventional (Standard) Valve Components (-00)					
Bonnet Gasket	Soft Iron	Monel	Monel	Monel	Monel
Spindle	410 Stainless Steel	410 Stainless Steel	Monel	Monel	Monel
Eductor Tube	316 Stainless Steel	316 Stainless Steel	316 Stainless Steel	Monel	Monel
Bonnet Plug	Carbon Steel	Carbon Steel	Carbon Steel	Monel	Monel
Bellows Valve Components (-30)					
Bonnet Gasket	Soft Iron	Soft Iron	Soft Iron	Monel	Monel
Spindle	410 Stainless Steel	410 Stainless Steel	410 Stainless Steel	Monel	Monel
Bellows	Inconel 625 LCF	Inconel 625 LCF	Monel	Monel	Monel
Bellows Nut, Bellows Flange	316L Stainless Steel	316L Stainless Steel	Monel	Monel	Monel
Bellows Gasket	Soft Iron	Monel	Monel	Monel	Monel

Notes:

- The materials in red denote variation from standard material construction.
- To specify valves, add material designation to the valve type, 1910L/M3 or 1910-30L/M3.

- Nickel Copper Alloy (Per ASME Code Case 1750-22).
- Or Inconel X-750.
- Else Customer Specified.
- With Flexible Graphite Filler (Spiral Wound).

Materials

Corrosive Service

Corrosive Service, Hastelloy Material ^{1 & 2}				
Component	Construction Variation			
	H1	H2	H3	H4
Common Components (-00 and -30)				
Base (1905-1918)	ASME SA216 WCC CS	ASME SA216 WCC CS	Nickel Alloy ³	Nickel Alloy ³
Base (1920-1928)	ASME SA217 WC6 AS	ASME SA217 WC6 AS	Nickel Alloy ³	Nickel Alloy ³
Base Plug (1905-1918), Cap Bolt	Carbon Steel	Carbon Steel	Hastelloy C	Hastelloy C
Base Plug (1920-1928)	316 Stainless Steel	316 Stainless Steel	Hastelloy C	Hastelloy C
Nozzle, Disc - Solid Metal Flat Seat	Hastelloy C	Hastelloy C	Hastelloy C	Hastelloy C
Adjusting Ring, Adjusting Ring Pin	316 Stainless Steel	Hastelloy C	Hastelloy C	Hastelloy C
Adjusting Ring Pin Gasket	Soft Iron	Monel	Monel	Monel
Disc - Thermodisc, Disc Retainer	Inconel X-750	Inconel X-750	Inconel X-750	Inconel X-750
Disc Holder	316 Stainless Steel	Hastelloy C	Hastelloy C	Hastelloy C
Guide Gasket	Soft Iron	Monel	Monel	Monel
Bonnet	ASME SA216 WCC CS	ASME SA216 WCC CS	Nickel Alloy ²	Nickel Alloy ²
Bonnet Gasket	Soft Iron	Monel	Monel	Monel
Base Stud	ASME SA193 B7 AS	ASME SA193 B7 AS	Hastelloy C	Hastelloy C
Stud Nut	ASME SA194 2H CS	ASME SA194 2H CS	Hastelloy C	Hastelloy C
Spindle Retainer	Inconel X-750	Inconel X-750	Inconel X-750	Inconel X-750
Spring Washer	Carbon Steel	Carbon Steel	Carbon Steel	Hastelloy C
Spring (-450° to -76°F)	316 Stainless Steel	Not Applicable	Not Applicable	Not Applicable
Spring (-75° to 800°F)	Alloy Steel	Alloy Steel	Alloy Steel	Hastelloy C
Spring (801° to 1000°F)	Tungsten Steel ⁴	Tungsten Steel ⁴	Tungsten Steel ⁴	Hastelloy C
Screwed Cap, Bolted Cap,	Carbon Steel	Carbon Steel	Hastelloy C	Hastelloy C
Packed Cap, Sealing Plug	Carbon Steel	Carbon Steel	Hastelloy C	Hastelloy C
Plain Cap	Malleable Iron	Malleable Iron	Not Applicable	Not Applicable
Cap Set Screw	Carbon Steel	Carbon Steel	Not Applicable	Not Applicable
Cap Gasket	Soft Iron	Monel	Monel	Monel
Release Nut, Release Locknut, Gag	Carbon Steel	Carbon Steel	Carbon Steel	Carbon Steel
Lever	Malleable Iron	Malleable Iron	Malleable Iron ⁵	Malleable Iron ⁵
Lifting Fork, Top Lever, Drop Lever	Malleable Iron	Malleable Iron	Malleable Iron	Malleable Iron
Lever Shaft, Packing Nut	410/416 Stainless Steel	410/416 Stainless Steel	410/416 Stainless Steel	410/416 Stainless Steel
Packing	316 Stainless Steel ⁶	316 Stainless Steel ⁶	316 Stainless Steel ⁶	316 Stainless Steel ⁶
Sealing Plug Gasket	Soft Iron	Monel	Monel	Monel
Limit Washer (D-2 and E-2)	316 Stainless Steel	Hastelloy C	Hastelloy C	Hastelloy C
Standard Components (-00)				
Guide	316 Stainless Steel	Hastelloy C	Hastelloy C	Hastelloy C
Spindle	410 Stainless Steel	Hastelloy C	Hastelloy C	Hastelloy C
Adjusting Screw, Adjusting Screw Nut	416 Stainless Steel	Hastelloy C	Hastelloy C	Hastelloy C
Eductor Tube	316 Stainless Steel	316 Stainless Steel	Hastelloy C	Hastelloy C
Bonnet Plug	Carbon Steel	Carbon Steel	Hastelloy C	Hastelloy C
Bellows Components (-30)				
Guide	316 Stainless Steel	316 Stainless Steel	Hastelloy C	Hastelloy C
Spindle	410 Stainless Steel	410 Stainless Steel	Hastelloy C	Hastelloy C
Adjusting Screw, Adjusting Screw Nut	416 Stainless Steel	416 Stainless Steel	Hastelloy C	Hastelloy C
Bellows	Inconel 625 LCF	Hastelloy C	Hastelloy C	Hastelloy C
Bellows Nut, Bellows Flange	316L Stainless Steel	Hastelloy C	Hastelloy C	Hastelloy C
Bellows Gasket	Soft Iron	Monel	Monel	Monel

Notes:

1. The materials in red denote variation from standard material construction.
2. To specify valves, add material designation to the valve type, 1910L/H3 or 1910-30L/H3.
3. ASME SA494 CW12MW Nickel Alloy.
4. Or Inconel X-750.
5. Else Customer Specified.
6. With Flexible Graphite Filler (Spiral Wound).

Materials

Corrosive Service

Duplex Material ^{1 & 2}		
Component	Construction Variation	
	D1	D2
Common Components (-00 and -30)		
Base (1905-1918)	ASME SA216 WCC Carbon Steel	ASME SA216 WCC Carbon Steel
Base (1920-1928)	ASME SA217 WC6 Alloy Steel	ASME SA217 WC6 Alloy Steel
Base Plug (1905-1918)	Carbon Steel	Carbon Steel
Base Plug (1920-1928)	316 Stainless Steel	316 Stainless Steel
Nozzle	Duplex ASME SA479 UNS 31803 ³	Duplex ASME SA479 UNS 31803 ³
Adjusting Ring	316 Stainless Steel	Duplex ASME SA479 UNS 31803 ³
Adjusting Ring Pin	316 Stainless Steel	Duplex SA479 UNS S31803
Adjusting Ring Pin Gasket	Soft Iron	Monel
Disc - Solid Metal Flat Seat	Duplex ASME SA479 UNS 31803 ³	Duplex ASME SA479 UNS 31803 ³
Disc - Thermodisc	Inconel X-750	Inconel X-750
Disc Retainer, Spindle Retainer	Inconel X-750	Inconel X-750
Disc Holder	316 Stainless Steel	Duplex ASME SA479 UNS 31803 ³
Guide Gasket, Cap Gasket	Soft Iron	Monel
Bonnet	ASME SA216 WCC Carbon Steel	ASME SA216 WCC Carbon Steel
Base Stud	ASME SA193 B7 Alloy Steel	ASME SA193 B7 Alloy Steel
Stud Nut	ASME SA194 2H Carbon Steel	ASME SA194 2H Carbon Steel
Spring Washer	Carbon Steel	Carbon Steel
Spring (-20° to 800°F)	Alloy Steel	Alloy Steel
Spring (801° to 1000°F)	Tungsten Steel or Inconel X-750	Tungsten Steel or Inconel X-750
Screwed Cap, Bolted Cap, Packed Cap	Carbon Steel	Carbon Steel
Plain Cap	Malleable Iron	Malleable Iron
Cap Bolt	Carbon Steel	Carbon Steel
Cap Set Screw	Carbon Steel	Carbon Steel
Release Nut, Release Locknut, Gag	Carbon Steel	Carbon Steel
Lever	Malleable Iron	Malleable Iron
Lifting Fork	Malleable Iron	Malleable Iron
Lever Shaft, Packing Nut	410/416 Stainless Steel	410/416 Stainless Steel
Packing	316 Stainless Steel ⁴	316 Stainless Steel ⁴
Top Lever, Drop Lever	Malleable Iron	Malleable Iron
Sealing Plug	Carbon Steel	Carbon Steel
Sealing Plug Gasket	Soft Iron	Monel
Limit Washer (D-2 and E-2)	316 Stainless Steel	316 Stainless Steel
Conventional (Standard) Valve Material (-00)		
Guide	316 Stainless Steel	Duplex ASME SA479 UNS 31803 ³
Bonnet Gasket	Soft Iron	Monel
Spindle	410 Stainless Steel	Duplex SA479 UNS S31803
Adjusting Screw, Adjusting Screw Nut	416 Stainless Steel	Duplex SA479 UNS S31803
Eductor Tube	316 Stainless Steel	316 Stainless Steel
Bonnet Plug	Carbon Steel	Carbon Steel
Bellows Valve Material (-30)		
Guide	316 Stainless Steel	316 Stainless Steel
Bonnet Gasket	Soft Iron	Soft Iron
Spindle	410 Stainless Steel	410 Stainless Steel
Adjusting Screw, Adjusting Screw Nut	416 Stainless Steel	416 Stainless Steel
Bellows	Inconel 625 LCF	Inconel 625 LCF
Bellows Nut, Bellows Flange	316L Stainless Steel	316L Stainless Steel
Bellows Gasket	Soft Iron	Monel

Notes:

1. The materials in red denote variation from standard material construction.
2. To specify valves, add material designation to the valve type, 1910L/D2 or 1910-30L/D2.
3. Or SA995 UNS J93345.
4. With Flexible Graphite Filler (Spiral Wound).

Materials

Corrosive Service

Duplex Material ^{1 & 2}		
Component	Construction Variation	
	D3	D4
Common Components (-00 and -30)		
Base (1905-1918)	ASME SA995 CE8MN UNS J93345 Duplex SS	ASME SA995 CE8MN UNS J93345 Duplex SS
Base Plug (1905-1918)	Duplex ASME SA479 UNS 31803	Duplex ASME SA479 UNS 31803
Nozzle	Duplex ASME SA479 UNS 31803 ³	Duplex ASME SA479 UNS 31803 ³
Adjusting Ring	Duplex ASME SA479 UNS 31803 ³	Duplex ASME SA479 UNS 31803 ³
Adjusting Ring Pin	Duplex SA479 UNS S31803	Duplex SA479 UNS S31803
Adjusting Ring Pin Gasket	Monel	Monel
Disc - Solid Metal Flat Seat	Duplex ASME SA479 UNS 31803 ³	Duplex ASME SA479 UNS 31803 ³
Disc - Thermodisc	Inconel X-750	Inconel X-750
Disc Retainer, Spindle Retainer	Inconel X-750	Inconel X-750
Disc Holder	Duplex ASME SA479 UNS 31803 ³	Duplex ASME SA479 UNS 31803 ³
Guide Gasket, Cap Gasket	Monel	Monel
Bonnet	ASME SA995 CE8MN UNS J93345 Duplex	ASME SA995 CE8MN UNS J93345 Duplex
Base Stud	ASME SA193 B8M Alloy Steel	ASME SA193 B8M Alloy Steel
Stud Nut	ASME SA194 8M Carbon Steel	ASME SA194 8M Carbon Steel
Spring Washer	Carbon Steel	Duplex ASME SA479 UNS S31803
Spring (-20° to 800°F)	Alloy Steel	Inconel X-750
Spring (801° to 1000°F)	Tungsten Steel or Inconel X-750	Inconel X-750
Screwed Cap, Bolted Cap, Packed Cap	Duplex ASME SA479 UNS 31803 ³	Duplex ASME SA479 UNS 31803 ³
Plain Cap	Not Applicable	Not Applicable
Cap Bolt	ASTM A193 B8M Stainless Steel	ASTM A193 B8M Stainless Steel
Release Nut, Release Locknut, Gag	Carbon Steel	Carbon Steel
Lever	Malleable Iron else Customer Specified	Malleable Iron else Customer Specified
Lifting Fork	Malleable Iron	Malleable Iron
Lever Shaft, Packing Nut	410/416 Stainless Steel	410/416 Stainless Steel
Packing	316 Stainless Steel ⁴	316 Stainless Steel ⁴
Sealing Plug	Duplex ASME SA479 UNS S31803	Duplex ASME SA479 UNS S31803
Sealing Plug Gasket	Monel	Monel
Limit Washer (D-2 and E-2)	Duplex UNS S31803	Duplex UNS S31803
Conventional (Standard) Valve Material (-00)		
Guide	Duplex ASME SA479 UNS 31803 ³	Duplex ASME SA479 UNS 31803 ³
Bonnet Gasket	Monel	Monel
Spindle	Duplex SA479 UNS S31803	Duplex SA479 UNS S31803
Adjusting Screw, Adjusting Screw Nut	Duplex SA479 UNS S31803	Duplex SA479 UNS S31803
Eductor Tube	ASTM A789 ⁵	ASTM A789 ⁵
Bonnet Plug	Duplex ASME SA479 UNS S31803	Duplex ASME SA479 UNS S31803
Bellows Valve Material (-30)		
Guide	316 Stainless Steel	316 Stainless Steel
Bonnet Gasket	Monel	Monel
Spindle	410 Stainless Steel	410 Stainless Steel
Adjusting Screw, Adjusting Screw Nut	416 Stainless Steel	416 Stainless Steel
Bellows	Inconel 625	Inconel 625
Bellows Nut, Bellows Flange	Inconel 625	Inconel 625
Bellows Gasket	Monel	Monel

Notes:

1. The materials in red denote variation from standard material construction.
2. To specify valves, add material designation to the valve type, 1910L/D2 or 1910-30L/D2.
3. Or SA995 UNS J93345
4. With Flexible Graphite Filler (Spiral Wound)
5. Or ASME SA789 SAF 2507 Super Duplex UNS S32750

Materials

Low Temperature

Special Materials for Low Process Fluid Temperature ^{1 & 2}			
Nomenclature	Construction Variation		
	L1	L2	L3
	-21 to -75°F (-29 to -59°C)	-76 to -150°F (-60 to -101°C)	-151 to -450°F (-102 to -268°C)
Common Components (-00 and -30)			
Base (1905-1918)	ASME SA351 CF8M ⁵	ASME SA351 CF8M	ASME SA351 CF8M
Base Plug (1905-1918), Nozzle	316 Stainless Steel	316 Stainless Steel	316 Stainless Steel
Adjusting Ring, Adjusting Ring Pin, Guide	316 Stainless Steel	316 Stainless Steel	316 Stainless Steel
Adjusting Ring Pin Gasket, Sealing Plug Gasket	Monel	Monel	Monel
Guide Gasket, Bonnet Gasket, Cap Gasket	Monel	Monel	Monel
Disc - Solid Metal Flat Seat, Disc Holder	316 Stainless Steel	316 Stainless Steel	316 Stainless Steel ⁵
Disc - Thermodisc, Disc Retainer	Inconel X-750	Inconel X-750	Inconel X-750
Bonnet	ASME SA216 WCC CS	ASME SA351 CF8M	ASME SA351 CF8M
Base Stud	ASME SA193 B8M St.St.	ASME SA193 B8M St.St.	ASME SA193 B8M St.St.
Stud Nut	ASME SA194 8M St.St.	ASME SA194 8M St.St.	ASME SA194 8M St.St.
Spindle	410 Stainless Steel	316 Stainless Steel	316 Stainless Steel ⁵
Spindle Retainer	Inconel X-750	Inconel X-750	Inconel X-750
Spring Washer	Carbon Steel	316 Stainless Steel	316 Stainless Steel ⁵
Sealing Plug	Carbon Steel	316 Stainless Steel	316 Stainless Steel
Spring (-450° to -76°F)	Not Applicable	316 Stainless Steel	316 Stainless Steel
Spring (-75° to 800°F)	Alloy Steel	Not Applicable	Not Applicable
Adjusting Screw	416 Stainless Steel	316 Stainless Steel	316 Stainless Steel ⁵
Adjusting Screw Nut	416 Stainless Steel	316 Stainless Steel	316 Stainless Steel
Screwed Cap, Bolted Cap, Packed Cap	Carbon Steel	316 Stainless Steel	316 Stainless Steel
Plain Cap, Lifting Fork	Malleable Iron	316 Stainless Steel	316 Stainless Steel
Cap Bolt	Carbon Steel	316 Stainless Steel	ASME SA193 B8M St.St.
Cap Set Screw, Release Nut, Release Locknut	Carbon Steel	316 Stainless Steel	316 Stainless Steel
Lever, Top Lever, Drop Lever	Malleable Iron	Malleable Iron	Malleable Iron
Lever Shaft, Packing Nut	410/416 Stainless Steel	410/416 Stainless Steel	410/416 Stainless Steel
Packing	316 Stainless Steel ⁴	316 Stainless Steel ⁴	316 Stainless Steel ⁴
Gag	Carbon Steel	Carbon Steel	Carbon Steel
Limit Washer (D-2 and E-2)	316 Stainless Steel	316 Stainless Steel	316 Stainless Steel
Conventional (Standard) Components (-00)			
Eductor Tube	316 Stainless Steel	316 Stainless Steel	316 Stainless Steel
Bonnet Plug	Carbon Steel	316 Stainless Steel	316 Stainless Steel
Bellows Components (-30)			
Bellows	Inconel 625 LCF	Inconel 625 LCF	316L Stainless Steel
Bellows Nut , Bellows Flange	316L Stainless Steel	316L Stainless Steel	316L Stainless Steel
Bellows Gasket	Monel	Monel	Monel

Notes:

- The materials in red denote variation from standard material construction.
- To specify valves, add material designation to the valve type, 1910L/L2 or 1910-30L/L2.
- ASME SA352 LCC can be substituted for bases down to -50°F (-45.6°C) when requested.
- With Flexible Graphite Filler (Spiral Wound).
- With Titanium Nitride Coating.

Materials

Low Temperature

Special Materials for Low Ambient Temperatures ^{1, 2 & 3} (to -50°F or -45°C)		
Component	Construction Variation	
	C1	C2 ⁴
Common Components (-00 and -30)		
Base (1905-1918)	ASME SA352 LCC Carbon Steel	ASME SA351 CF8M Stainless Steel
Base Plug (1905-1918), Nozzle	316 Stainless Steel	316 Stainless Steel
Adjusting Ring, Adjusting Ring Pin	316 Stainless Steel	316 Stainless Steel
Adjusting Ring Pin Gasket, Guide Gasket	Soft Iron	Soft Iron
Disc - Solid Metal Flat Seat	316 Stainless Steel	316 Stainless Steel
Disc - Thermodisc	616 Stainless Steel	616 Stainless Steel
Disc Retainer, Spindle Retainer	Inconel X-750	Inconel X-750
Disc Holder, Guide, Spring Washer	316 Stainless Steel	316 Stainless Steel
Bonnet Gasket, Cap Gasket, Sealing Plug Gasket	Soft Iron	Soft Iron
Bonnet	ASME SA352 LCC Carbon Steel	ASME SA351 CF8M Stainless Steel
Base Stud	ASME SA193 B8M Stainless Steel	ASME SA193 B8M Stainless Steel
Stud Nut	ASME SA194 8M Stainless Steel	ASME SA194 8M Stainless Steel
Spindle	410 Stainless Steel	410 Stainless Steel
Spring (-50° to 800°F)	Alloy Steel	Alloy Steel
Adjusting Screw, Adjusting Screw Nut	416 Stainless Steel	416 Stainless Steel
Screwed Cap, Bolted Cap, Packed Cap	LCC Carbon Steel	LCC Carbon Steel
Plain Cap, Lever, Lifting Fork, Top Lever, Drop Lever	Malleable Iron	Malleable Iron
Cap Bolt, Gag, Sealing Plug	Carbon Steel	Carbon Steel
Cap Set Screw, Limit Washer (D-2 and E-2)	316 Stainless Steel	316 Stainless Steel
Release Nut, Release Locknut	Carbon Steel	Carbon Steel
Lever Shaft, Packing Nut	410/416 Stainless Steel	410/416 Stainless Steel
Packing	316 Stainless Steel ⁵	316 Stainless Steel ⁵
Conventional (Standard) Valve Components (-00)		
Eductor Tube	316 Stainless Steel	316 Stainless Steel
Bonnet Plug	316 Stainless Steel	316 Stainless Steel
Bellows Valve Components (-30)		
Bellows	Inconel 625 LCF	Inconel 625 LCF
Bellows Nut, Bellows Flange	316L Stainless Steel	316L Stainless Steel
Bellows Gasket	Soft Iron	Soft Iron

Notes:

1. The materials in red denote variation from standard material construction.
2. Media temperature may impact valve temperature. Contact factory for assistance.
3. To specify valves, add material designation to the valve type, 1910L/C1 or 1910-30L/C1.
4. If impact testing is required, use the "C1" material variation.
5. With Flexible Graphite Filler (Spiral Wound).

Materials

High Temperature

Special Materials for Low Process Fluid Temperature ^{1 & 2}			
Component	T1		T2 ^{3 & 4}
	1001 to 1200°F (538°C to 649°C)		1201 to 1500°F (649 to 815°C)
	Standard Valve Material (-00)	Bellows Valve Material (-30)	Standard Valve Material (-00)
Base(1920-1928)	ASME SA351 CF8M St.St.	ASME SA351 CF8M St.St.	ASME SA351 CF8M St.St. ⁵
Base Plug(1920-1928), Nozzle	316 Stainless Steel	316 Stainless Steel	316 Stainless Steel
Adjusting Ring, Adjusting Ring Pin	316 Stainless Steel	316 Stainless Steel	316 Stainless Steel
Adjusting Ring Pin Gasket, Guide Gasket	Monel	Monel	Monel
Disc - Solid Metal Flat Seat	316 Stainless Steel	316 Stainless Steel	Inconel X-750
Disc - Thermodisc, Disc Retainer	Inconel X-750	Inconel X-750	Inconel X-750
Disc Holder	316 Stainless Steel ⁶	316 Stainless Steel ⁶	316 Stainless Steel ⁶
Guide	316 Stainless Steel	316 Stainless Steel	316 Stainless Steel ⁶
Bonnet	ASME SA351 CF8M St.St.	ASME SA351 CF8M St.St.	ASME SA351 CF8M St.St. ⁷
Bonnet Gasket, Sealing Plug Gasket	Monel	Monel	Not Applicable
Base Stud	ASME SA193 B8M Alloy Steel	ASME SA193 B8M Alloy Steel	ASME SA193 B8M Alloy Steel
Stud Nut	ASME SA194 8M Carbon Steel	ASME SA194 8M Carbon Steel	ASME SA194 8M Carbon Steel
Spindle	410 Stainless Steel	410 Stainless Steel	316 Stainless Steel (Stellited)
Spindle Retainer	Inconel X-750	Inconel X-750	Inconel X-750
Spring Washer	Carbon Steel	Carbon Steel	410 Stainless Steel
Spring	Tungsten Steel or Inconel X-750	Tungsten Steel or Inconel X-750	Tungsten Steel or Inconel X-750
Adjusting Screw	416 Stainless Steel	416 Stainless Steel	416 Stainless Steel
Adjusting Screw Nut	416 Stainless Steel	416 Stainless Steel	416 Stainless Steel
Screwed Cap, Bolted Cap, Packed Cap	Carbon Steel	Carbon Steel	Carbon Steel
Plain Cap, Cap Bolt, Gag, Sealing Plug	Carbon Steel	Carbon Steel	Carbon Steel
Cap Set Screw	Carbon Steel	Carbon Steel	Malleable Iron
Cap Gasket	Monel	Monel	Not Applicable
Release Nut, Release Locknut	Carbon Steel	Carbon Steel	Carbon Steel
Lever, Lifting Fork, Top Lever, Drop Lever	Malleable Iron	Malleable Iron	Malleable Iron
Lever Shaft, Packing Nut	410/416 Stainless Steel	410/416 Stainless Steel	410/416 Stainless Steel
Packing	316 Stainless Steel ⁸	316 Stainless Steel ⁸	316 Stainless Steel ⁸
Eductor Tube, Bonnet Plug	316 Stainless Steel	Not Applicable	Not Applicable
Limit Washer (D-2 and E-2)	316 Stainless Steel	316 Stainless Steel	316 Stainless Steel
Bellows	Not Applicable	Inconel 625 LCF	Inconel 625 LCF
Bellows Nut, Bellows Flange	Not Applicable	Inconel 625	Inconel 625
Bellows Gasket	Not Applicable	Monel	Monel
Deflector Plate (Not Shown)	Not Applicable	Not Applicable	316 Stainless Steel

Notes:

- The materials in red denote variation from standard material construction.
- To specify valves, add material designation to the valve type, 1920L/T2 or 1920-30L/T2.
- All T2 valves have ANSI Class 300 outlet flanges.
- Consult factory for temperatures above 1500°F (815°C).
- Carbon content must be 0.04% or higher.
- Glide-Alloy Coated.
- Slotted Yoke Bonnet for T2. Slotted Bonnet not available for liquid service.
- With Flexible Graphite Filler (Spiral Wound).

Materials

1900 Valves for Lethal Service

In some industries, there are lethal service applications which require special consideration. If your application may be for lethal service, please review this information. "Lethal Service" should be prominently indicated in your discussions, inquiries, or purchase orders.

I. Definition

ASME B and PVC, Section VIII (Division 1) states that it is the responsibility of the user to state that the valve will be in lethal service.

IMPORTANT:

GE does not determine if a fluid is lethal. The customer must specify the fluid is lethal and paperwork should be clearly stamped to identify that the application is a lethal fluid.

The ASME Code definition is as follows:

Lethal Substance - Poisonous gases or liquids of such a nature that a very small amount of the gas or the vapor of the liquid, mixed or unmixed with air, is dangerous to life when inhaled.

ASME B31.3 - A chemical plant and petroleum refining piping standard, supplies a similar definition, which it calls a "Category M Fluid Service."

II. Valve Requirements for Lethal Service Application

- A. Only closed bonnet valves with a screwed or bolted cap or packed lever can be used for lethal service.
- B. Valve model numbers that are acceptable for lethal service after modification are 1905/1910 conventional and bellows flanged valves.
- C. It is recommended that a soft-seat design be used for improved tightness.
- D. When service temperature exceeds 450°F (232°C), bolting material review is required by GE Engineering team.
- E. Use non-sparking material for flammable media. Examples are Bronze, 316 Stainless Steel, and Monel.

III. Base, Bonnet, and Cap Casting Requirements

- A. Each casting requires 100 percent visual inspection
- B. Each casting requires complete surface examination either by magnetic particle for steel castings or liquid penetrant for stainless castings.
- C. Each casting shall have radiographic examination.
- D. All repairs to base, bonnet and cap castings must be documented.
- E. All threads must be inspected for continuity of threads
- F. Hydro test should be 10 minutes.
- G. The base drain plug is to be sealed by seal welding a plug of the same material as the base.
- H. The bonnet vent is to be sealed in accordance with paragraph G for conventional valves (non-bellows). Bellows valves are to have the vent connection vented to a safe location.

IV. Additional Requirements

- A. Each bellows requires a mass spectrometer leak test to 1×10^{-7} cc/sec to be imposed.
- B. It is necessary to seal the nozzle-base joint. The customer must state its preference between a seal weld or O-ring joint, depending on conformance of its maintenance practice.
- C. The nozzle and disc require hydro testing with a hold time for a minimum of 10 minutes.
- D. Cleaning procedures and lubricants used shall be acceptable for lethal service.
- E. Back pressure testing is required.

Materials

O-ring Selection

O-ring Selection Table - Durometer																				
Valve Type	Set Pressure Range																			
	50 ¹				70 - 75 ¹				90 ²				Teflon ³ (-300°F to 200°F) (-184.4 to 93.3°C)				Teflon ³ (201°F to 500°F) (93.9 to 260°C)			
	psig		barg		psig		barg		psig		barg		psig		barg		psig		barg	
	min.	max.	min.	max.	min.	max.	min.	max.	min.	max.	min.	max.	min.	max.	min.	max.	min.	max.	min.	max.
1900D and E	5	75	0.34	5.17	76	800	5.24	55.16	801	2000	55.23	137.90	2000	6000	137.90	413.69	285	6000	19.65	413.69
1900F	5	75	0.34	5.17	76	800	5.24	55.16	801	2000	55.23	137.90	2000	6000	137.90	413.69	285	6000	19.65	413.69
1900G	5	75	0.34	5.17	76	780	5.24	53.78	781	1900	53.85	131.00	1900	3705	131.00	255.45	285	3705	19.65	255.45
1900H	5	75	0.34	5.17	76	780	5.24	53.78	781	1900	53.85	131.00	1900	2750	131.00	189.61	285	2750	19.65	189.61
1900J	5	75	0.34	5.17	76	780	5.24	53.78	781	1900	53.85	131.00	1900	2700	131.00	186.16	285	2700	19.65	186.16
1900K	5	75	0.34	5.17	76	580	5.24	39.99	581	1400	40.06	96.53	1400	2220	96.53	153.06	250	2220	17.24	153.06
1900L	5	75	0.34	5.17	76	580	5.24	39.99	581	1400	40.06	96.53	1400	1500	96.53	103.42	155	1500	10.69	103.42
1900M	5	75	0.34	5.17	76	580	5.24	39.99	581	1100	40.06	75.84	-	-	-	-	140	1100	9.65	75.84
1900N	5	75	0.34	5.17	76	580	5.24	39.99	581	1000	40.06	68.95	-	-	-	-	90	1000	6.21	68.95
1900P	5	70	0.34	4.83	71	500	4.90	34.47	501	1000	34.54	68.95	-	-	-	-	75	1000	5.17	68.95
1900Q	5	70	0.34	4.83	71	420	4.90	28.96	421	600	29.03	41.37	-	-	-	-	80	600	5.52	41.37
1900R	5	50	0.34	3.45	51	420	3.52	28.96	421	600	29.03	41.37	-	-	-	-	60	300	4.14	20.68
1900T	5	50	0.34	3.45	51	200	3.52	13.79	201	300	13.86	20.68	-	-	-	-	30	300	2.07	20.68
1900U	5	50	0.34	3.45	51	200	3.52	13.79	201	300	13.86	20.68	-	-	-	-	30	300	2.07	20.68
1900V	-	-	-	-	15	150	1.03	10.34	151	300	10.41	20.68	-	-	-	-	15	300	1.03	20.68
1900W	-	-	-	-	7	150	0.48	10.34	151	300	10.41	20.68	-	-	-	-	15	300	1.03	20.68

Notes:

1. Maximum set pressure for silicone compounds is half of the maximum value.
2. The E962-90D O-Ring can be used in steam service in applications down to 15 psig (1.03 barg).
3. Teflon will not be supplied for conditions that deviate from these ranges.

Materials

O-ring Selection

O-ring Temperature Limits				
Materials	Durometer	Description ¹	Temp. Limits (°F)	Temp. Limits (°C)
Nitrile	50	N299-50 or N1009-50	-45 to +225	-43 to +107
	70	N674-70	-40 to +250	-40 to +121
	90	N552-90	-40 to +250	-40 to +121
	70 ²	N1173-70	-25 to +300	-31 to +149
Ethylene/Propylene	50	E1100-50 or E981-50	-65 to +212	-53 to +100
	70	E603-70	-65 to +212	-53 to +100
	75 and 80 ⁵	E740-75 and E515-80	-70 to +250	-57 to +121
	90	E962-90 ⁴	-70 to +500	-57 to +260
	75 ⁵	E962-75	-60 to +250/400	-51 to +121/204
Fluorocarbon	50	V986-50	-15 to +400	-26 to +204
	75	V747-75 or V884-75	-15 to +400	-26 to +204
	90	V894-90 or V709-90	-15 to +400	-26 to +204
Neoprene	50	C267-50	-45 to +300	-43 to +149
	70	C944-70 or C873-70	-45 to +300	-43 to +149
Silicone	50	S595-50	-65 to +437	-53 to +225
	70	S604-70	-65 to +437	-53 to +225
Teflon	N/A	Teflon	-300 to +505	-184 to +263
Kalrez ⁶	82	1050LF	-42 to +550	-41 to +288
	75	4079	-58 to +601	-50 to +316
	91	3018	-35 to +601	-37 to +316
	65	1058	-40 to +500	-40 to +260

Notes:

1. Contact factory for O-ring selection for various fluids.
2. Consult factory before using. For use with freon 134A/ester oil service.
3. Set pressure ranges from durometer table for 70-75 Durometer shall apply to these compounds (for nuclear service, radiation environment).
4. EPR962-90D can be used on steam service to lower pressure limit of 15 psig (1.03 barg).
5. Can be used upto 400°F (204°C) for steam applications.
6. Consult factory before selecting.

Accessories

1900 Caps, Levers, and Accessories

Lifting Mechanisms

The purpose of the lifting mechanism is to open the valve when the pressure under the valve disc is lower than the set pressure. These mechanisms are available in three basic types: plain lever, packed lever and air-operated lifting device. The lifting lever may be used as follows:

1. To lift the disc from the valve seat periodically during the operation of equipment to be sure that the disc holder is not frozen in the guide as a result of corrosion, coking, sulphur deposits, etc. This will promote protection of the unit at all times. Operating pressure under the disc should be approximately 75 percent of the set pressure when lifting in accordance with the ASME Code; otherwise the lever assembly could be damaged.
2. To remove foreign particles that are sometimes trapped under the seat as the valve closes. Immediate cleaning of the valve seat with the pressure of the media, by use of the lifting lever, will correct an otherwise leaking valve, save maintenance costs at a later date and in some cases avoid equipment shutdown.
3. To vent equipment to the atmosphere or discharge piping.

Plain Lever

This lever assembly is not pressure-tight and should not be used where back pressure is present or where the escape of vapor discharging from an open valve is undesirable around the lever assembly.

Packed Lever

As indicated by the name, this lifting lever assembly is packed around the lever shaft, so that leakage will not occur around the upper part of the valve when the valve is open or when back pressure is present. The packed lifting lever should be used when positive protection against leakage is required.

Bolted Cap

Consolidated Standard Safety Relief valves are supplied with screwed caps but bolted caps are available.

Gag

The purpose of the gag is to hold the safety relief valve closed while equipment is undergoing an operational hydrostatic test. This is the only purpose for which the gag is intended, and it can be accomplished by pulling the gag hand-tight. Force should never be used. The gag should never be left in the valve during the operation of the equipment. It should be removed after each use and hung in a safe, convenient location and the sealing plug reinstated and properly torqued.

ASME B and PVC, Section VIII, Lever

- ASME Codes require that a lifting lever must be supplied with the valve for steam, air, and hot water service over 140°F (60°C) applications. While this need not be a sealed lifting mechanism, the ASME Codes do recommend that sealed lifting mechanisms be used. The lifting lever may be omitted under Code Case 2203, but GE requires that all orders for pressure relief valves without levers or blowdown valves for steam, air, and water over 140°F (60°C) state specifically that the valves are being purchased per Code Case 2203. The purchaser is responsible for obtaining jurisdictional authorization for use of Code Case 2203.
- Thermal relief valves: When ASME Code stamped valves are used for thermal relief applications, the ASME Code guidelines shall be followed in regard to lifting levers.

Accessories

1900 Caps, Levers, and Accessories

Air-Operated Lifting Device

The Air-Operated Lifting Device uses an air cylinder to obtain lifting power to open the valve from a remote control station. Normal operation of the safety relief valve is independent of the lifting device.

Please specify actual required conditions, otherwise the device will be supplied to operate with at least 75 percent of set pressure under the disc in accordance with the ASME Code.

Requirements for special application: valve size, set pressure, minimum pressure at which the valve must be kept open, air pressure for operator, or electrical characteristics for solenoid operation.

Regulated air, not to exceed 100 psig, is required for operation.

Air-Operated Lifting Device

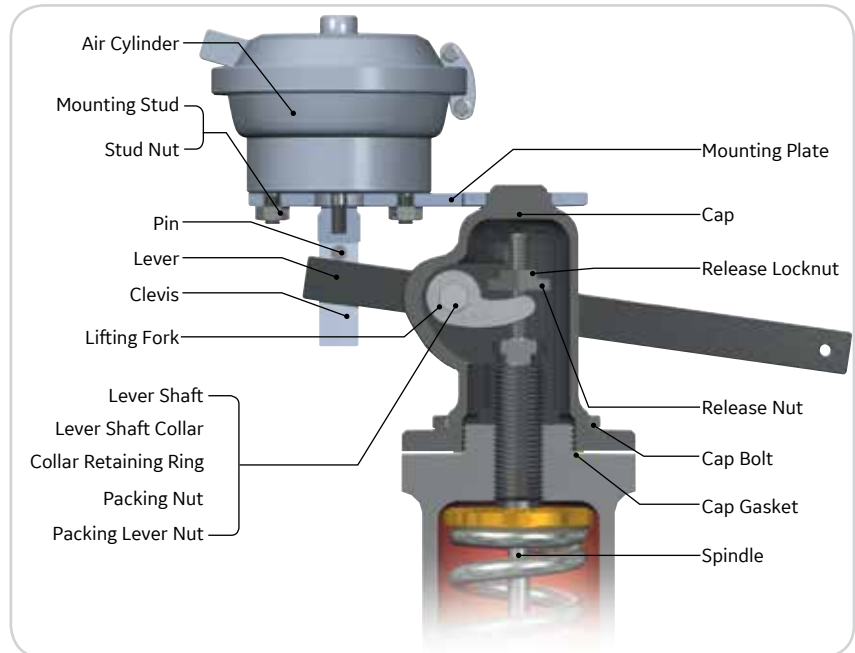

Valve Position Indicators

A valve position indicator, in general, is a micro switch apparatus used for remote indication of the opening of a safety relief valve. It is designed to activate warning devices such as control panel lights or auditory indicators. This option enhances the control function of operators located in remote control stations. Please advise voltage requirements for proper selection of micro switch when ordering.



Slotted Bonnet



Steam Jacket



Vent Bug Screen
(Available in 1900-30 bellows valve only)



Forged Body
(Severe Service, Special Materials, Special Dimensions)

Accessories

Packed Lever

As indicated by the name, this lifting lever assembly is packed around the lever shaft, so that leakage will not occur around the upper part of the valve when the valve is open or when back pressure is present. The packed lifting lever should be used when positive protection against leakage is required.

Packed Lever

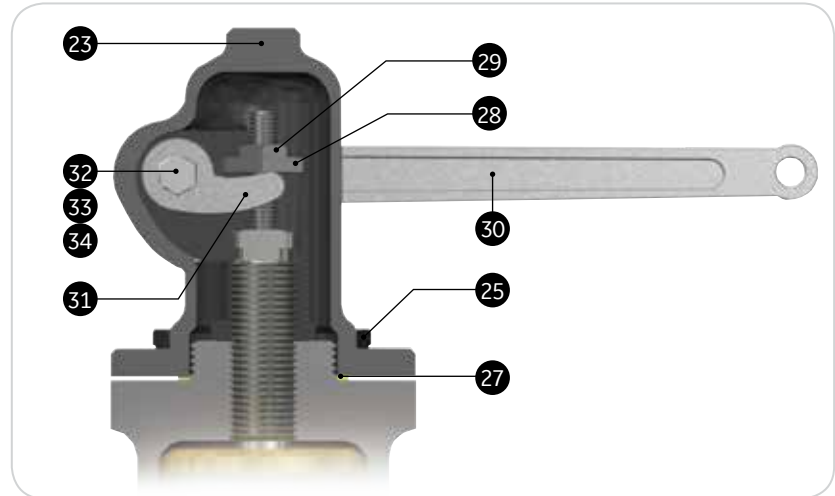

Plain Lever

This lever assembly is not pressure-tight and should not be used where back pressure is present or where the escape of vapor from an open valve is undesirable around the lever assembly. It is designed with either a one- or two-piece lever as illustrated below. The design is based on valve size and/or valve set pressure.

One-Piece Lever Design

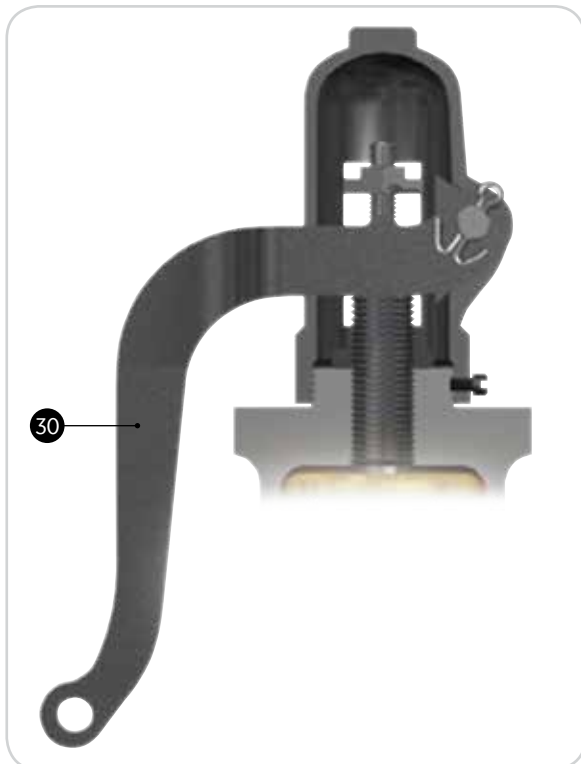

Two-Piece Lever Design

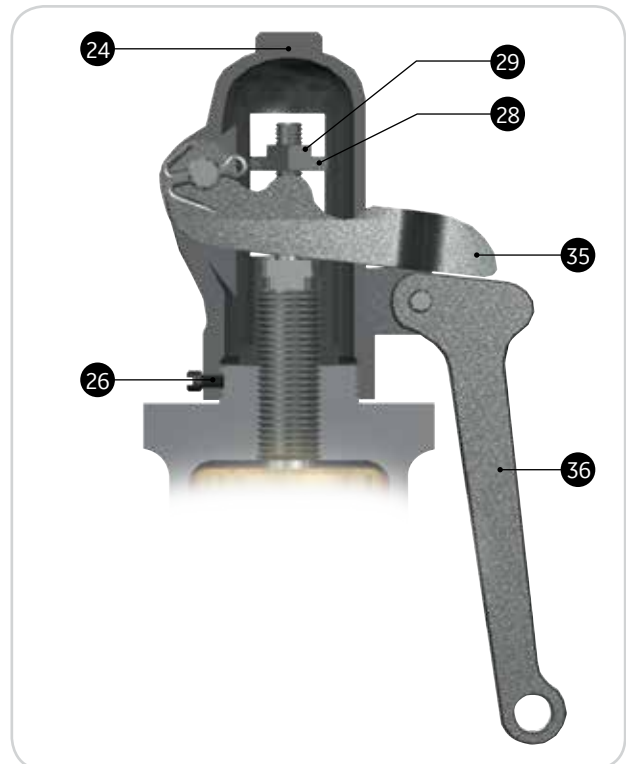

Accessories

Bolted Cap

Consolidated standard safety relief valves are supplied with screwed caps, but bolted caps are available.

Bolted Cap

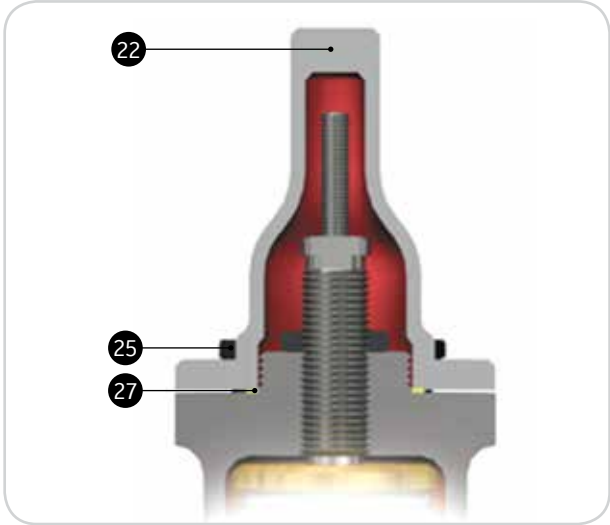

Cap with Gag

Cap with Gag

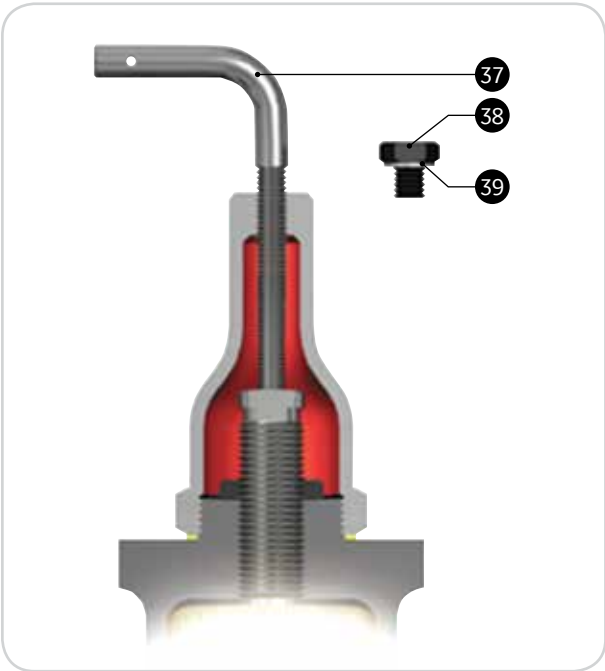

The purpose of the gag is to hold the safety relief valve closed while equipment is being subjected to an operational hydrostatic test. This is the only purpose for which the gag is intended, and it can be accomplished by pulling the gag hand-tight. Force should never be used. The gag should never be left in the valve during the operation of the equipment. It should be removed each time after using and hung in a safe, convenient location.

Accessories

Cap and Lever Construction

Standard, Alloy, Monel, Hastelloy and Duplex Material ¹					
Cap Type	Component	Construction Variation			
		Std., A1, A2, H1, H2, L1, M1, MB, M2, D1, D2, S2, T1, T2	Alloy 20	Hastelloy	HF Alky
			A3 and A4	H3 and H4	HA
Packed Lever	23 Cap	Carbon Steel	Alloy 20	Hastelloy C	Carbon Steel
	25 Cap Bolts	Carbon Steel	Alloy 20	Hastelloy C	Carbon Steel
	27 Cap Gasket	Soft Iron ³	Monel	Monel	Monel
	30 Packed Lever	Malleable Iron	Malleable Iron	Malleable Iron	Malleable Iron
	32 Lever Shaft	410/416 Stainless Steel	410/416 Stainless Steel	410/416 Stainless Steel	410/416 Stainless Steel
	33 Packing	316 Stainless Steel ²	316 Stainless Steel ²	316 Stainless Steel ²	316 Stainless Steel ⁴
	34 Packing Nut	410/416 SS	410/416 SS	410/416 SS	410/416 SS
	31 Lifting Fork	Malleable Iron	Malleable Iron	Malleable Iron	Malleable Iron
	28 Release Nut	Carbon Steel	Carbon Steel	Carbon Steel	Carbon Steel
	29 Release Lock Nut	Carbon Steel	Carbon Steel	Carbon Steel	Carbon Steel
Plain Lever	24 Cap	Malleable Iron	N/A	N/A	Malleable Iron
	26 Cap Set Screw	Carbon Steel	N/A	N/A	Carbon Steel
	35 Top Lever	Malleable Iron	N/A	N/A	Malleable Iron
	36 Drop Lever	Malleable Iron	N/A	N/A	Malleable Iron
	28 Release Nut	Carbon Steel	N/A	N/A	Carbon Steel
	29 Release Lock Nut	Carbon Steel	N/A	N/A	Carbon Steel
	30 Plain Lever (One Piece)	Malleable Iron	N/A	N/A	Malleable Iron
Bolted Cap	22 Cap	Carbon Steel	Alloy 20	Hastelloy C	Carbon Steel
	25 Cap Bolts	Carbon Steel	Alloy 20	Hastelloy C	Carbon Steel
	27 Cap Gasket	Soft Iron ³	Monel	Monel	Monel
Gag	37 Gag Bolt	Carbon Steel	Carbon Steel	Carbon Steel	Carbon Steel
	38 Sealing Plug	Carbon Steel	Alloy 20	Hastelloy C	Carbon Steel
	39 Plug Gasket ⁵	Soft Iron	Monel	Monel	Monel

Notes:

1. The materials in red denote variation from standard material construction.
2. With Flexible Graphite Filler (Spiral Wound).
3. Gasket material is Monel for A2, H2, MB, M2, D2 and S2 construction.
4. Or Graphlock

Accessories

Cap and Lever Construction

Monel, Stainless, and Low Temperature Material ¹						
Cap Type	Component	Construction Variation				
		Monel	Duplex	Stainless Steel	Low Temperature	
		M3 and M4	D3 and D4	S3 and S4	L2 and L3	
Packed Lever	23	Cap	Monel	Duplex ASME SA479 ³	316 Stainless Steel	316 Stainless Steel
	25	Cap Bolts	Monel K500	ASTM A193 B8M Stainless Steel	ASME SA193 B8M SS	ASME SA193 B8M SS
	27	Cap Gasket	Monel	Monel	Monel	Monel
	30	Packed Lever	Malleable Iron	Malleable Iron	Malleable Iron	Malleable Iron
	32	Lever Shaft	410/416 St.St.	410/416 Stainless Steel	316 Stainless Steel	410/416 St.St.
	33	Packing	316 Stainless Steel ²	316 Stainless Steel ²	316 Stainless Steel ²	316 Stainless Steel ²
	34	Packing Nut	410/416 St.St.	410/416 Stainless Steel	316 Stainless Steel	410/416 St.St.
	31	Lifting Fork	Malleable Iron	Malleable Iron	316 Stainless Steel	316 Stainless Steel
	28	Release Nut	Carbon Steel	Carbon Steel	316 Stainless Steel	316 Stainless Steel
29	Release Lock Nut	Carbon Steel	Carbon Steel	316 Stainless Steel	316 Stainless Steel	
Plain Lever	24	Cap	N/A	N/A	316 Stainless Steel	316 Stainless Steel
	26	Cap Set Screw	N/A	N/A	B8M Stainless Steel	316 Stainless Steel
	35	Top Lever	N/A	N/A	Malleable Iron	Malleable Iron
	36	Drop Lever	N/A	N/A	Malleable Iron	Malleable Iron
	28	Release Nut	N/A	N/A	Carbon Steel	Carbon Steel
	29	Release Lock Nut	N/A	N/A	Carbon Steel	Carbon Steel
	30	Plain Lever (One Piece)	N/A	N/A	Malleable Iron	Malleable Iron
Bolted Cap	22	Cap	Monel	Duplex ASME SA479 ³	316 Stainless Steel	316 Stainless Steel
	25	Cap Bolts	Monel K500	ASTM A193 B8M Stainless Steel	ASME SA193 B8M SS	ASME SA193 B8M SS
	27	Cap Gasket	Monel	Monel	Monel	Monel
Gag	37	Gag Bolt	Carbon Steel	Carbon Steel	Carbon Steel	Carbon Steel
	38	Sealing Plug	Monel	Duplex ASME SA479 UNS S31803	316 Stainless Steel	316 Stainless Steel
	39	Plug Gasket	Monel	Monel	Monel	Monel

Notes:

1. The materials in red denote variation from standard material construction.
2. With Flexible Graphite Filler (Spiral Wound).
3. Duplex ASME SA479 UNS 31803 or SA995 UNS J93345

Accessories

Bolt-on Jackets

Jacketing of Relief Valves

GE offers simple solutions to your heating problems with Bolt-on Jackets for Consolidated valves.

Viscous materials that freeze or harden in relief valve nozzles create hazardous conditions. Process pipe jacketing or tracing may not offer sufficient heat to the area in and around the relief valve seat. During a pressure surge, some of the solid materials may stick in and around the seating area, keeping the valve from functioning and re-seating properly. This can result in leakage around the valve seating surface.

The solution to this problem is the Bolt-on Jacket, a two-piece aluminum casting has a steel pressure chamber embedded in the aluminum jacket casting. The pressure chamber is fabricated of standard pressure vessel materials for various heating fluids and service temperatures. The chamber is configured and tested in accordance with the ASME B and PVC, Section VIII, Div. I. The jacket casting conducts heat from the pressure chamber and rapidly distributes it evenly over the outer surface of the relief valve.

The aluminum casting distributes heat only, it carries no pressure load at any time. Heating fluid is transferred from one half of the jacket to the other by an external connector. A thin layer of heat transfer cement is used between the jacket and the relief valve to promote effective heat transfer by filling any air gaps between the jacket and the relief valve.

Typical Bolt-on Jacket



Bolt-on Jacket halves bolt together for quick installation and unbolt for ready access to the relief valve for easy maintenance. The jackets cover from flange to flange providing uniform heat to all process-wetted surfaces. Standard service ratings for the jacket are 150 psig and 500°F. Higher ratings are available upon request.

Bolt-on Jackets may be ordered with adjacent flange coverage and with a variety of heating medium connections. Canadian registration is available for all provinces.

Bolt-on Jackets are operating successfully on relief valves in many different process service applications worldwide. Buyers should consider jacketing the relief valves whenever the adjacent vessel or piping is heated in some manner. The following process applications typically require jacketing of the relief valve:

- Acrylic Acid
- Ammonium Nitrate
- Coal Tars
- Caprolactam
- Cyanuric Chloride
- DMT
- DNT
- Fluoropolymers
- LLDPE
- Olefins
- Phosphorous
- Polypropylene
- Polystyrene Resins
- Phthalic Anhydride
- Sulphuric Acid
- Sulphur Dioxide
- Some Surfactants
- Tall Oils
- TMA

To ensure we provide the proper jacket coverage; please answer the following questions:

- 1.** Is the process operating at elevated temperatures?
- 2.** What is the process?
- 3.** What is the temperature of the process being maintained?
- 4.** What heating medium is being used in your jacket? What pressure and temperature is this medium?
- 5.** What type of jacket connections are required?
- 6.** How is the temperature being maintained on the process piping and other equipment (valves, pumps, meters, etc.)?

The relief valve will probably need a Bolt-on Jacket if it is operating in one of the process services listed above or if the adjacent piping and equipment is heated.

Contact the factory for assistance.

© 2018 Baker Hughes, a GE company. All rights reserved.

Dimensions and Weights

1900 Flanged Series Conventional Safety Relief Valve

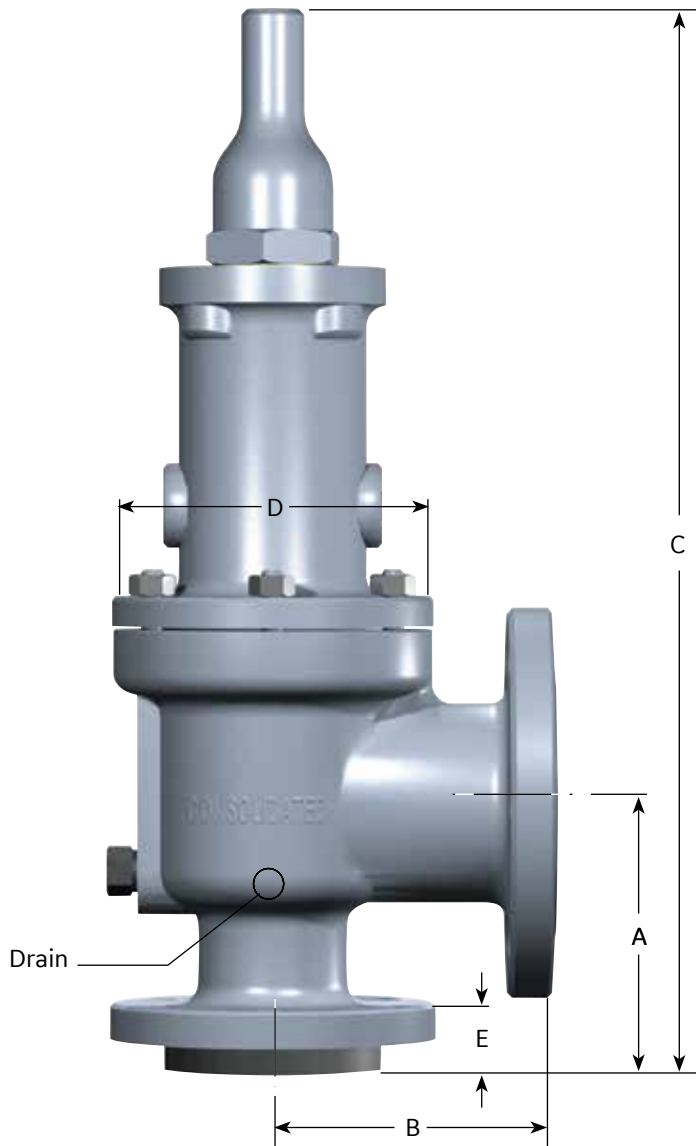

This table applies to the standard 1900 Series regardless of materials of construction.

The table provides overall dimensions for standard valve size and pressure class offerings as shown on pages 5-9.

If the valve you are reviewing has an inlet or outlet size different from standard valve offerings, the dimensions "A" through "E" and weight may not apply. Consult the factory for non-standard valve dimensions.

Note:

Inlet and outlet combinations as well as orifices sizes shown in the following tables are compliant with API Standard 526, Sixth Edition, 2009. For replacement valves that do not comply with this edition, contact the factory for verification of dimensions and inlet and outlet combinations. The U, V and W orifice valves are not an API approved orifice size.

Dimensions and Weights

Valve Data - D Orifice														
Valve Type	A		B		C				D		E		Approximate Weight	
	in.	mm	in.	mm	Standard		Bellows		in.	mm	in.	mm	lb.	kg
					in.	mm	in.	mm						
1905	4.13	104.9	4.50	114.3	17.00	431.8	18.00	457.2	5.44	138.2	1.13	28.7	40	18.1
1906	4.13	104.9	4.50	114.3	17.00	431.8	18.00	457.2	5.44	138.2	1.38	35.1	40	18.1
1910	4.13	104.9	4.50	114.3	17.50	444.5	18.50	469.9	5.44	138.2	1.38	35.1	50	22.7
1912	4.13	104.9	4.50	114.3	18.25	463.6	19.25	489.0	6.31	160.3	1.38	35.1	55	24.9
1914	4.13	104.9	5.50	139.7	21.75	552.5	22.75	577.9	7.81	198.4	1.94	49.3	95	43.1
1916	4.13	104.9	5.50	139.7	21.75	552.5	22.75	577.9	7.81	198.4	1.94	49.3	95	43.1
1918	5.50	139.7	7.00	177.8	26.50	673.1	27.50	698.5	8.88	225.6	2.44	62.0	150	68.0
1920	4.13	104.9	4.50	114.3	17.50	444.5	18.50	469.9	5.44	138.2	1.38	35.1	50	22.7
1922	4.13	104.9	4.50	114.3	17.50	444.5	18.50	469.9	5.44	138.2	1.38	35.1	50	22.7
1924	4.13	104.9	5.50	139.7	21.75	552.5	22.75	577.9	7.81	198.4	1.94	49.3	95	43.1
1926	4.13	104.9	5.50	139.7	21.75	552.5	22.75	577.9	7.81	198.4	1.94	49.3	95	43.1
1928	5.50	139.7	7.00	177.8	26.50	673.1	27.50	698.5	8.88	225.6	2.44	62.0	150	68.0

Valve Data - E Orifice														
Valve Type	A		B		C				D		E		Approximate Weight	
	in.	mm	in.	mm	Standard		Bellows		in.	mm	in.	mm	lb.	kg
					in.	mm	in.	mm						
1905	4.13	104.9	4.50	114.3	17.00	431.8	18.00	457.2	5.44	138.2	1.13	28.7	40	18.1
1906	4.13	104.9	4.50	114.3	17.00	431.8	18.00	457.2	5.44	138.2	1.38	35.1	40	18.1
1910	4.13	104.9	4.50	114.3	17.50	444.5	18.50	469.9	5.44	138.2	1.38	35.1	50	22.7
1912	4.13	104.9	4.50	114.3	18.25	463.6	19.25	489.0	6.31	160.3	1.38	35.1	55	24.9
1914	4.13	104.9	5.50	139.7	21.75	552.5	22.75	577.9	7.81	198.4	1.94	49.3	95	43.1
1916	4.13	104.9	5.50	139.7	21.75	552.5	22.75	577.9	7.81	198.4	1.94	49.3	95	43.1
1918	5.50	139.7	7.00	177.8	26.50	673.1	27.50	698.5	8.88	225.6	2.44	62.0	150	68.0
1920	4.13	104.9	4.50	114.3	17.50	444.5	18.50	469.9	5.44	138.2	1.38	35.1	50	22.7
1922	4.13	104.9	4.50	114.3	17.50	444.5	18.50	469.9	5.44	138.2	1.38	35.1	50	22.7
1924	4.13	104.9	5.50	139.7	21.75	552.5	22.75	577.9	7.81	198.4	1.94	49.3	95	43.1
1926	4.13	104.9	5.50	139.7	21.75	552.5	22.75	577.9	7.81	198.4	1.94	49.3	95	43.1
1928	5.50	139.7	7.00	177.8	26.50	673.1	27.50	698.5	8.88	225.6	2.44	62.0	150	68.0

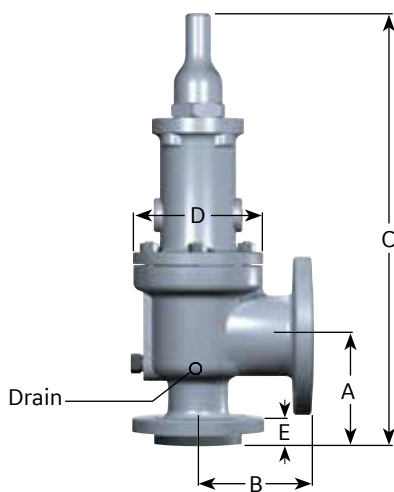

Dimensions and Weights

Valve Data - F Orifice														
Valve Type	A		B		C				D		E		Approximate Weight	
	in.	mm	in.	mm	Standard		Bellows		in.	mm	in.	mm	lb.	kg
					in.	mm	in.	mm						
1905	4.88	124.0	4.75	120.7	17.75	450.9	18.75	476.3	5.44	138.2	1.25	31.8	40	18.1
1906	4.88	124.0	4.75	120.7	17.75	450.9	18.75	476.3	5.44	138.2	1.50	38.1	45	20.4
1910	4.88	124.0	6.00	152.4	18.25	463.6	19.25	489.0	5.44	138.2	1.56	39.6	50	22.7
1912	4.88	124.0	6.00	152.4	19.00	482.6	20.00	508.0	6.31	160.3	1.56	39.6	60	27.2
1914	4.88	124.0	6.50	165.1	22.50	571.5	23.50	596.9	7.81	198.4	1.94	49.3	100	45.4
1916	4.88	124.0	6.50	165.1	22.50	571.5	23.50	596.9	7.81	198.4	1.94	49.3	100	45.4
1918	5.50	139.7	7.00	177.8	26.50	673.1	27.50	698.5	8.88	225.6	2.44	62.0	150	68.0
1920	4.88	124.0	6.00	152.4	18.25	463.6	19.25	489.0	5.44	138.2	1.56	39.6	50	22.7
1922	4.88	124.0	6.00	152.4	18.25	463.6	19.25	489.0	5.44	138.2	1.56	39.6	50	22.7
1924	4.88	124.0	6.50	165.1	22.50	571.5	23.50	596.9	7.81	198.4	1.94	49.3	100	45.4
1926	4.88	124.0	6.50	165.1	22.50	571.5	23.50	596.9	7.81	198.4	1.94	49.3	100	45.4
1928	5.50	139.7	7.00	177.8	26.50	673.1	27.50	698.5	8.88	225.6	2.44	62.0	150	68.0

Valve Data - G Orifice														
Valve Type	A		B		C				D		E		Approximate Weight	
	in.	mm	in.	mm	Standard		Bellows		in.	mm	in.	mm	lb.	kg
					in.	mm	in.	mm						
1905	4.88	124.0	7.75	196.9	17.75	450.9	19.00	482.6	5.44	138.2	1.25	31.8	55	24.9
1906	4.88	124.0	4.75	120.7	17.75	450.9	19.00	482.6	5.44	138.2	1.50	38.1	55	24.9
1910	4.88	124.0	6.00	152.4	18.25	463.6	19.50	495.3	5.44	138.2	1.56	39.6	60	27.2
1912	4.88	124.0	6.00	152.4	19.00	482.6	20.25	514.4	6.31	160.3	1.56	39.6	65	29.5
1914	4.88	124.0	6.50	165.1	22.50	571.5	23.75	603.3	7.81	198.4	1.94	49.3	95	43.1
1916	6.13	155.7	6.75	171.5	23.75	603.3	25.00	635.0	7.81	198.4	2.19	55.6	100	45.4
1918	6.13	155.7	6.75	171.5	23.75	603.3	25.00	635.0	7.81	198.4	2.69	68.3	110	49.9
1920	4.88	124.0	6.00	152.4	18.25	463.6	19.50	495.3	5.44	138.2	1.56	39.6	60	27.2
1922	4.88	124.0	6.00	152.4	19.00	482.6	20.25	514.4	6.31	160.3	1.56	39.6	65	29.5
1924	4.88	124.0	6.50	165.1	22.50	571.5	23.75	603.3	7.81	198.4	1.94	49.3	95	43.1
1926	6.13	155.7	6.75	171.5	23.75	603.3	25.00	635.0	7.81	198.4	2.19	55.6	100	45.4
1928	6.13	155.7	6.75	171.5	23.75	603.3	25.00	635.0	7.81	198.4	2.69	68.3	110	49.9

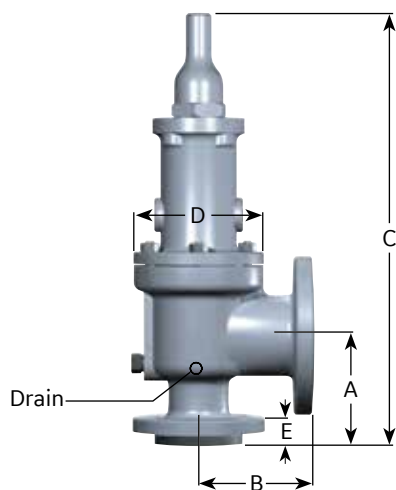

Dimensions and Weights

Valve Data - H Orifice														
Valve Type	A		B		C				D		E		Approximate Weight	
	in.	mm	in.	mm	Standard		Bellows		in.	mm	in.	mm	lb.	kg
					in.	mm	in.	mm						
1905	5.13	130.3	4.88	124.0	19.50	495.3	19.50	495.3	6.31	160.3	1.25	31.8	60	27.2
1906	5.13	130.3	4.88	124.0	19.50	495.3	19.50	495.3	6.31	160.3	1.56	39.6	60	27.2
1910	5.13	130.3	4.88	124.0	20.25	514.4	20.25	514.4	6.31	160.3	1.69	42.9	65	29.5
1912	6.06	153.9	6.38	162.1	23.00	584.2	23.00	584.2	7.00	177.8	1.69	42.9	85	38.6
1914	6.06	153.9	6.38	162.1	26.00	660.4	26.00	660.4	8.25	209.6	2.19	55.6	130	59.0
1916	6.06	153.9	6.38	162.1	26.00	660.4	26.00	660.4	8.25	209.6	2.19	55.6	140	63.5
1920	5.13	130.3	4.88	124.0	20.25	514.4	20.25	514.4	6.31	160.3	1.69	42.9	65	29.5
1922	5.13	130.3	4.88	124.0	20.25	514.4	20.25	514.4	6.31	160.3	1.69	42.9	65	29.5
1924	6.06	153.9	6.38	162.1	23.00	584.2	23.00	584.2	7.00	177.8	2.19	55.6	90	40.8
1926	6.06	153.9	6.38	162.1	26.00	660.4	26.00	660.4	8.25	209.6	2.19	55.6	140	63.5

Valve Data - J Orifice														
Valve Type	A		B		C				D		E		Approximate Weight	
	in.	mm	in.	mm	Standard		Bellows		in.	mm	in.	mm	lb.	kg
					in.	mm	in.	mm						
1905	5.38	136.7	4.88	124.0	21.25	539.8	21.25	539.8	6.88	174.8	1.31	33.3	75	34.0
1906	5.38	136.7	4.88	124.0	21.25	539.8	21.25	539.8	6.88	174.8	1.56	39.6	75	34.0
1910	7.25	184.2	7.13	181.1	25.63	651.0	25.63	651.0	7.38	187.5	1.81	46.0	100	45.4
1912	7.25	184.2	7.13	181.1	29.88	759.0	29.88	759.0	9.00	228.6	1.81	46.0	170	77.1
1914	7.25	184.2	7.13	181.1	29.75	755.7	29.75	755.7	9.00	228.6	2.19	55.6	195	88.5
1916	7.25	184.2	7.13	181.1	29.75	755.7	29.75	755.7	9.00	228.6	2.56	65.0	220	99.8
1920	7.25	184.2	7.13	181.1	25.63	651.0	25.63	651.0	7.38	187.5	1.81	46.0	100	45.4
1922	7.25	184.2	7.13	181.1	25.63	651.0	25.63	651.0	7.38	187.5	1.81	46.0	100	45.4
1924	7.25	184.2	7.13	181.1	29.88	759.0	29.88	759.0	9.00	228.6	2.31	58.7	180	81.6
1926	7.25	184.2	7.13	181.1	29.75	755.7	29.75	755.7	9.00	228.6	2.56	65.0	220	99.8

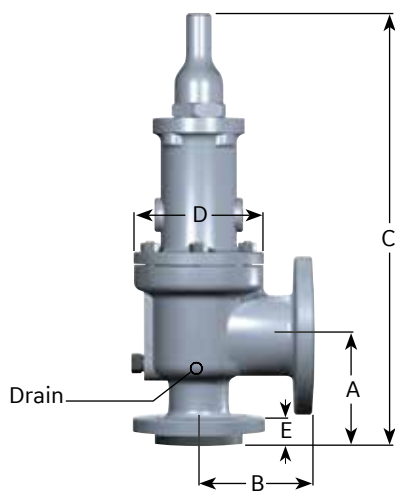

Dimensions and Weights

Valve Data - K Orifice														
Valve Type	A		B		C				D		E		Approximate Weight	
	in.	mm	in.	mm	Standard		Bellows		in.	mm	in.	mm	lb.	kg
					in.	mm	in.	mm						
1905	6.13	155.7	6.38	162.1	25.50	647.7	24.50	622.3	7.38	187.5	1.44	36.6	110	49.9
1906	6.13	155.7	6.75	171.5	24.50	622.3	24.50	622.3	7.38	187.5	1.81	46.0	115	52.2
1910	6.13	155.7	6.38	162.1	28.00	711.2	28.00	711.2	7.75	196.9	1.94	49.3	140	63.5
1912	7.25	184.2	7.13	181.1	29.25	743.0	29.25	743.0	7.75	196.9	1.94	49.3	150	68.0
1914	7.81	198.4	8.50	215.9	35.25	895.4	35.25	895.4	10.50	266.7	2.19	55.6	300	136.1
1916	7.75	196.9	8.50	215.9	35.25	895.4	35.25	895.4	10.50	266.7	2.56	65.0	320	145.1
1920	6.13	155.7	6.38	162.1	28.00	711.2	28.00	711.2	7.75	196.9	1.94	49.3	140	63.5
1922	6.13	155.7	6.38	162.1	28.00	711.2	28.00	711.2	7.75	196.9	1.94	49.3	140	63.5
1924	7.81	198.4	8.50	215.9	35.25	895.4	35.25	895.4	10.50	266.7	2.19	55.6	300	136.1
1926	7.75	196.9	8.50	215.9	35.25	895.4	35.25	895.4	10.50	266.7	2.56	65.0	320	145.1

Valve Data - L Orifice														
Valve Type	A		B		C				D		E		Approximate Weight	
	in.	mm	in.	mm	Standard		Bellows		in.	mm	in.	mm	lb.	kg
					in.	mm	in.	mm						
1905	6.13	155.7	6.50	165.1	28.75	730.3	28.75	730.3	8.88	225.6	1.44	36.6	140	63.5
1906	6.13	155.7	6.50	165.1	28.75	730.3	28.75	730.3	8.88	225.6	1.81	46.0	145	65.8
1910	7.06	179.3	7.13	181.1	32.00	812.8	32.00	812.8	9.50	241.3	1.94	49.3	220	99.8
1912	7.06	179.3	8.00	203.2	32.00	812.8	32.00	812.8	9.50	241.3	2.19	55.6	230	104.3
1914	7.75	196.9	8.75	222.3	37.25	946.2	37.25	946.2	12.25	311.2	2.44	62.0	360	163.3
1916	7.75	196.9	8.75	222.3	37.25	946.2	37.25	946.2	12.25	311.2	2.81	71.4	370	167.8
1920	7.06	179.3	7.13	181.1	32.00	812.8	32.00	812.8	9.50	241.3	1.94	49.3	220	99.8
1922	7.06	179.3	8.00	203.2	32.00	812.8	32.00	812.8	9.50	241.3	2.19	55.6	230	104.3
1924	7.75	196.9	8.75	222.3	37.25	946.2	37.25	946.2	12.25	311.2	2.44	62.0	360	163.3
1926	7.75	196.9	8.75	222.3	37.25	946.2	37.25	946.2	12.25	311.2	2.81	71.4	370	167.8

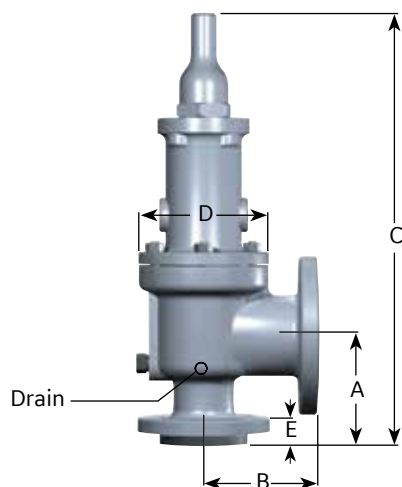

Dimensions and Weights

Valve Data - M Orifice														
Valve Type	A		B		C				D		E		Approximate Weight	
	in.	mm	in.	mm	Standard		Bellows		in.	mm	in.	mm	lb.	kg
					in.	mm	in.	mm						
1905	7.00	177.8	7.25	184.2	29.75	755.7	29.75	755.7	9.38	238.3	1.63	41.4	185	83.9
1906	7.00	177.8	7.25	184.2	29.75	755.7	29.75	755.7	9.38	238.3	1.94	49.3	190	86.2
1910	7.00	177.8	7.25	184.2	32.00	812.8	32.00	812.8	9.38	238.3	1.94	49.3	230	104.3
1912	7.00	177.8	8.00	203.2	36.25	920.8	36.25	920.8	10.75	273.1	2.19	55.6	300	136.1
1914	7.75	196.9	8.75	222.3	37.00	939.8	37.00	939.8	10.75	273.1	2.44	62.0	340	154.2
1920	7.00	177.8	7.25	184.2	32.00	812.8	32.00	812.8	9.38	238.3	1.94	49.3	230	104.3
1922	7.00	177.8	8.00	203.2	36.25	920.8	36.25	920.8	10.75	273.1	2.19	55.6	300	136.1
1924	7.75	196.9	8.75	222.3	37.00	939.8	37.00	939.8	10.75	273.1	2.44	62.0	340	154.2

Valve Data - N Orifice														
Valve Type	A		B		C				D		E		Approximate Weight	
	in.	mm	in.	mm	Standard		Bellows		in.	mm	in.	mm	lb.	kg
					in.	mm	in.	mm						
1905	7.75	196.9	8.25	209.6	33.00	838.2	33.00	838.2	10.13	257.3	1.63	41.4	220	99.8
1906	7.75	196.9	8.25	209.6	33.00	838.2	33.00	838.2	10.13	257.3	1.94	49.3	225	102.1
1910	7.75	196.9	8.25	209.6	34.25	870.0	34.25	870.0	10.50	266.7	1.94	49.3	260	117.9
1912	7.75	196.9	8.75	222.3	39.00	990.6	39.00	990.6	11.75	298.5	2.19	55.6	360	163.3
1914	7.75	196.9	8.75	222.3	39.00	990.6	39.00	990.6	11.75	298.5	2.44	62.0	380	172.4
1920	7.75	196.9	8.25	209.6	34.25	870.0	34.25	870.0	10.50	266.7	1.94	49.3	260	117.9
1922	7.75	196.9	8.75	222.3	39.00	990.6	39.00	990.6	11.75	298.5	2.19	55.6	360	163.3
1924	7.75	196.9	8.75	222.3	39.00	990.6	39.00	990.6	11.75	298.5	2.44	62.0	380	172.4

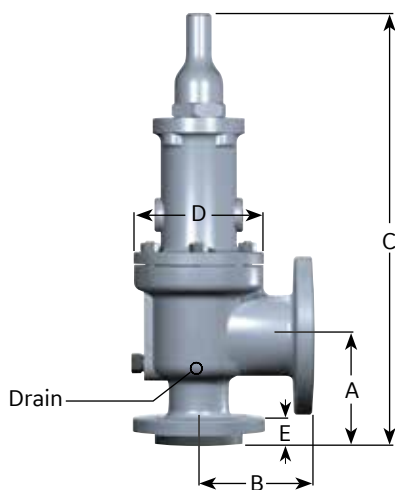

Dimensions and Weights

Valve Data - P Orifice														
Valve Type	A		B		C				D		E		Approximate Weight	
	in.	mm	in.	mm	Standard		Bellows		in.	mm	in.	mm	lb.	kg
					in.	mm	in.	mm						
1905	7.13	181.1	9.00	228.6	34.25	870.0	34.25	870.0	11.00	279.4	1.63	41.4	260	117.9
1906	7.13	181.1	9.00	228.6	24.25	616.0	34.25	870.0	11.00	279.4	1.94	49.3	270	122.5
1910	8.88	225.6	10.00	254.0	41.00	1041.4	41.00	1041.4	11.50	292.1	1.94	49.3	350	158.8
1912	8.88	225.6	10.00	254.0	43.50	1104.9	43.50	1104.9	13.88	352.6	2.19	55.6	530	240.4
1914	8.88	225.6	10.00	254.0	43.50	1104.9	43.50	1104.9	13.88	352.6	2.44	62.0	545	247.2
1920	8.88	225.6	10.00	254.0	41.00	1041.4	41.00	1041.4	11.50	292.1	1.94	49.3	350	158.8
1923	8.88	225.6	10.00	254.0	43.50	1104.9	43.50	1104.9	13.88	352.6	2.19	55.6	530	240.4
1924	8.88	225.6	10.00	254.0	43.50	1104.9	43.50	1104.9	13.88	352.6	2.44	62.0	545	247.2

Valve Data - Q Orifice														
Valve Type	A		B		C				D		E		Approximate Weight	
	in.	mm	in.	mm	Standard		Bellows		in.	mm	in.	mm	lb.	kg
					in.	mm	in.	mm						
1905	9.44	239.8	9.50	241.3	41.00	1041.4	41.00	1041.4	13.63	346.2	1.81	46.0	430	195.0
1906	9.44	239.8	9.50	241.3	41.00	1041.4	41.00	1041.4	13.63	346.2	13.63	346.2	445	201.8
1910	9.44	239.8	9.50	241.3	43.25	1098.6	43.25	1098.6	14.00	355.6	2.25	57.2	530	240.4
1912	9.44	239.8	9.50	241.3	46.00	1168.4	46.00	1168.4	14.25	362.0	2.69	68.3	645	292.6
1920	9.44	239.8	9.50	241.3	41.00	1041.4	41.00	1041.4	13.63	346.2	2.25	57.2	445	201.8
1922	9.44	239.8	9.50	241.3	46.00	1168.4	46.00	1168.4	14.25	362.0	2.69	68.3	645	292.6

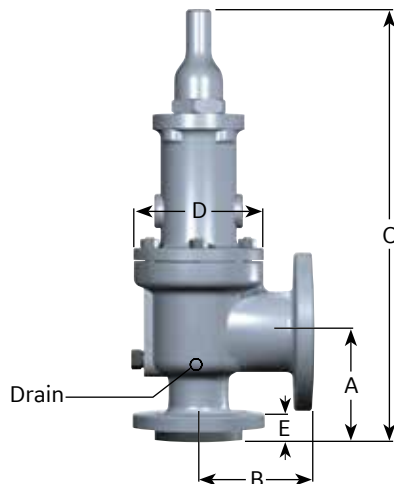

Dimensions and Weights

Valve Data - R Orifice														
Valve Type	A		B		C				D		E		Approximate Weight	
	in.	mm	in.	mm	Standard		Bellows		in.	mm	in.	mm	lb.	kg
					in.	mm	in.	mm						
1905	9.44	239.8	9.50	241.3	43.00	1092.2	43.00	1092.2	14.50	368.3	1.81	46.0	495	224.5
1906	9.44	239.8	9.50	241.3	43.00	1092.2	43.00	1092.2	14.50	368.3	2.25	57.2	510	231.3
1910	9.44	239.8	10.50	266.7	45.50	1155.7	45.50	1155.7	14.50	368.3	2.25	57.2	550	249.5
1912	9.44	239.8	10.50	266.7	47.50	1206.5	47.50	1206.5	15.13	384.3	2.69	68.3	675	306.2
1920	9.44	239.8	9.50	241.3	43.00	1092.2	43.00	1092.2	14.50	368.3	2.25	57.2	510	231.3
1922	9.44	239.8	10.50	266.7	47.50	1206.5	47.50	1206.5	15.13	384.3	2.69	68.3	675	306.2

Valve Data - T Orifice														
Valve Type	A		B		C				D		E		Approximate Weight	
	in.	mm	in.	mm	Standard		Bellows		in.	mm	in.	mm	lb.	kg
					in.	mm	in.	mm						
1905	10.88	276.4	11.00	279.4	47.50	1206.5	47.50	1206.5	16.50	419.1	1.94	49.3	620	281.2
1906	10.88	276.4	11.00	279.4	47.25	1200.2	47.25	1200.2	16.50	419.1	2.44	62.0	640	290.3
1910	10.88	276.4	11.00	279.4	53.38	1355.9	53.38	1355.9	16.50	419.1	2.44	62.0	840	381.0
1912	10.88	276.4	11.00	279.4	53.38	1355.9	53.38	1355.9	16.50	419.1	2.44	62.0	840	381.0
1920	10.88	276.4	11.00	279.4	53.38	1355.9	53.38	1355.9	16.50	419.1	2.44	62.0	840	381.0
1922	10.88	276.4	11.00	279.4	53.38	1355.9	53.38	1355.9	16.50	419.1	2.44	62.0	840	381.0

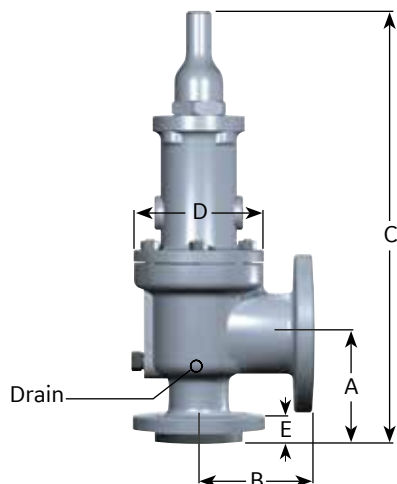

Dimensions and Weights

Valve Data - U Orifice														
Valve Type	A		B		C				D		E		Approximate Weight	
					Standard		Bellows							
	in.	mm	in.	mm	in.	mm	in.	mm	in.	mm	in.	mm	lb.	kg
1905	10.88	276.4	11.00	279.4	47.50	1206.5	47.50	1206.5	16.50	419.1	1.94	49.3	620	281.2
1906	10.88	276.4	11.00	279.4	47.25	1200.2	47.25	1200.2	16.50	419.1	2.44	62.0	640	290.3
1910	10.88	276.4	11.00	279.4	53.38	1355.9	53.38	1355.9	16.50	419.1	2.44	62.0	840	381.0
1920	10.88	276.4	11.00	279.4	53.38	1355.9	53.38	1355.9	16.50	419.1	2.44	62.0	840	381.0

Valve Data - V Orifice														
Valve Type	A		B		C				D		E		Approximate Weight	
					Standard		Bellows							
	in.	mm	in.	mm	in.	mm	in.	mm	in.	mm	in.	mm	lb.	kg
1905	12.00	304.8	16.00	406.4	62.00	1574.8	62.00	1574.8	21.75	552.5	2.00	50.8	1600	725.7
1906	12.00	304.8	16.00	406.4	62.00	1574.8	62.00	1574.8	21.75	552.5	2.69	68.3	1700	771.1
1910	12.00	304.8	16.00	406.4	66.00	1676.4	66.00	1676.4	24.50	622.3	2.69	68.3	2000	907.2
1920	12.00	304.8	16.00	406.4	66.00	1676.4	66.00	1676.4	24.50	622.3	2.69	68.3	2000	907.2

Valve Data - W Orifice														
Valve Type	A		B		C				D		E		Approximate Weight	
					Standard		Bellows							
	in.	mm	in.	mm	in.	mm	in.	mm	in.	mm	in.	mm	lb.	kg
1905	14.00	355.6	16.00	406.4	70.00	1778.0	70.00	1778.0	24.50	622.3	2.81	71.4	2800	1270.1
1906	14.00	355.6	16.00	406.4	70.00	1778.0	70.00	1778.0	24.50	622.3	2.94	74.7	2860	1297.3
1910	14.00	355.6	16.00	406.4	70.00	1778.0	70.00	1778.0	24.50	622.3	2.94	74.7	2860	1297.3
1920	14.00	355.6	16.00	406.4	70.00	1778.0	70.00	1778.0	24.50	622.3	2.81	71.4	2800	1270.1

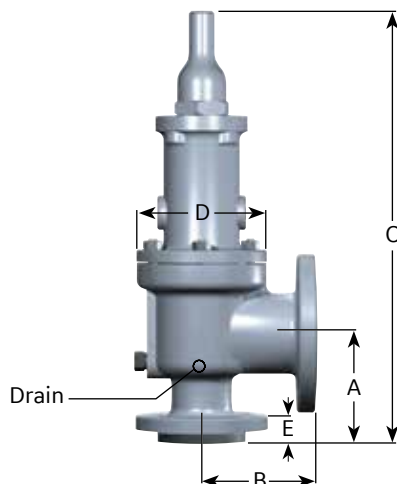

Pressure / Temperature

Pressure / Temperature Tables

How to Use Rating Tables

The included tables specify important data about the valve including valve sizes, flange ratings, pressure and temperature limits, back pressure ratings and materials with allowable temperature ranges.

After determining valve size from the Valve Sizing section, or capacity tables in this section, select the proper set of tables and graphs (in the following pages) for the size valve.

Enter the pressure and temperature graphs and determine valve type. Review the table of data for that size valve to get other pertinent information.

Notes:

1. The pressure/temperature limitations shown in the following tables are based on the limits specified in API526 applicable to the 1900 Series supplied in standard materials of construction. For pressure/temperature limitations of valves made from special materials, consult the factory or the SRVS sizing program. (Note that 1900-30 bellows design valve supplied with the standard Inconel 625 bellows is limited to a temperature range of 400°F (204°C) to 1500°F (816°C).)
2. ASME Class 300 outlet flanges are permitted for mating purposes only on valves that are normally supplied with standard ASME Class 150 pressure rating. For back pressure applications exceeding the ASME Class 150 pressure rating use SRVS sizing program or contact the factory for assistance.
3. When soft seats are used, they may govern the valve pressure/temperature rating.

Procedure

Example	
Valve Set Pressure	500 psig (34.47 barg)
Back Pressure	50 psig (3.45 barg)
Temperature	100°F (37.8°C)
Valve	"J"

Enter the graph on page 71 for the "J" size, select set pressure on the bottom scale at 500 psig (34.47 barg), follow this line vertically upward until it intersects the 100°F (38°C) line. The selection is a 1910Jc valve.

Results

Referring to the table on page 70, the valve is 3" (76.2 mm) - 300 x 4" (101.6 mm) - 150 with a carbon steel body and spring. The back pressure limit is satisfactory for 50 psig (3.45 barg) back pressure.

Springs

Within given temperature limits, alloy steel springs are specified. Most springs are of alloy steel construction which offers superior strength and corrosion-resistant properties.

Materials

The operating temperature should be used to select the materials in valves for fire-sizing applications.

Minimum Set Pressures				
The minimum set pressures of the 1900 flanged valves are in accordance with the following table.				
Orifice	Low Set Pressure Limit ²			
	Conventional Valve		Bellows Valve ¹	
	psig	barg	psig	barg
D	5	0.34	15	1.03
E	5	0.34	15	1.03
F	5	0.34	15	1.03
G	4	0.27	15	1.03
H	4	0.27	15	1.03
J	5	0.34	10	0.68
K	5	0.34	10	0.68
L	6	0.41	10	0.68
M	6	0.41	10	0.68

Notes:

- 1 The bonnet must be vented when a bellows is used.
- 2 Valves with set pressure less than 15 psig cannot be stamped with the ASME stamp.

Pressure / Temperature

Pressure Temperature Ratings for D Orifice ¹																				
API Ratings (D Orifice - 0.110 in ² (0.710 cm ²))															Backpressure Ratings @ 100°F (37.8°C)					
Valve Type	Connection				Flanged Ratings		Standard Material of Construction								Conventional		Bellows			
	Inlet		Outlet		Inlet	Outlet	-20 to 100°F (-28.9 to 37.8°C)		450°F (232.2°C)		800°F (426.7°C)		1000°F (537.8°C)				LP		HP	
	in.	mm	in.	mm	R.F. or R.J.	R.F.	psig	barg	psig	barg	psig	barg	psig	barg	psig	barg	psig	barg	psig	barg
1905	1.00	25.4	2.00	50.8	150	150	285	19.65	185	12.75	80	5.51	-	-	285	19.65	128	8.82	230	15.85
1906	1.00	25.4	2.00	50.8	300	150	285	19.65	285	19.65	285	19.65	-	-	285	19.65	128	8.82	230	15.85
1910	1.00	25.4	2.00	50.8	300	150	740	51.02	615	42.40	410	28.26	-	-	285	19.65	128	8.82	230	15.85
1912	1.00	25.4	2.00	50.8	600	150	1480	102.04	1235	85.15	825	56.88	-	-	285	19.65	128	8.82	230	15.85
1914	1.50	38.1	2.00	50.8	900	300	2220	153.06	1845	127.20	1235	85.15	-	-	600	41.36	128	8.82	500	34.47
1916	1.50	38.1	2.00	50.8	1500	300	3705	255.45	3080	212.35	2060	142.03	-	-	600	41.36	128	8.82	500	34.47
1918	1.50	38.1	3.00	76.2	2500	300	6000	413.68	6000	413.68	3430	236.49	-	-	740	51.02	128	8.82	500	34.47
1920	1.00	25.4	2.00	50.8	300	150	-	-	-	-	510	35.16	215	14.82	285	19.65	128	8.82	230	15.85
1922	1.00	25.4	2.00	50.8	600	150	-	-	-	-	1015	69.98	430	29.64	285	19.65	128	8.82	230	15.85
1924	1.50	38.1	2.00	50.8	900	300	-	-	-	-	1525	105.14	650	44.81	600	41.36	128	8.82	500	34.47
1926	1.50	38.1	2.00	50.8	1500	300	-	-	-	-	2540	175.12	1080	74.46	600	41.36	128	8.82	500	34.47
1928	1.50	38.1	3.00	76.2	2500	300	-	-	-	-	4230	291.64	1800	124.10	740	51.02	128	8.82	500	34.47

Pressure Temperature Ratings for D Orifice ¹																				
ASME Ratings (D Orifice - 0.128 in ² (0.825 cm ²) Actual)															Backpressure Ratings @ 100°F (37.8°C)					
Valve Type	Connection				Flanged Ratings		Standard Material of Construction								Conventional		Bellows			
	Inlet		Outlet		Inlet	Outlet	-20 to 100°F (-28.9 to 37.8°C)		450°F (232.2°C)		800°F (426.7°C)		1000°F (537.8°C)				LP		HP	
	in.	mm	in.	mm	R.F. or R.J.	R.F.	psig	barg	psig	barg	psig	barg	psig	barg	psig	barg	psig	barg	psig	barg
1905	1.00	25.4	2.00	50.8	150	150	290	19.99	185	12.75	80	5.51	-	-	290	19.99	128	8.82	290	19.99
1906	1.00	25.4	2.00	50.8	300	150	290	19.99	290	19.99	290	19.99	-	-	290	19.99	128	8.82	290	19.99
1910	1.00	25.4	2.00	50.8	300	150	750	51.71	685	47.22	410	28.26	-	-	290	19.99	128	8.82	290	19.99
1912	1.00	25.4	2.00	50.8	600	150	1500	103.42	1368	94.32	825	56.88	-	-	290	19.99	128	8.82	290	19.99
1914	1.50	38.1	2.00	50.8	900	300	2250	155.13	2053	141.54	1235	85.15	-	-	750	51.71	128	8.82	750	51.71
1916	1.50	38.1	2.00	50.8	1500	300	3750	258.55	3423	236.00	2055	141.68	-	-	750	51.71	128	8.82	750	51.71
1918	1.50	38.1	3.00	76.2	2500	300	6250	430.92	5703	393.20	3430	236.49	-	-	750	51.71	128	8.82	750	51.71
1920	1.00	25.4	2.00	50.8	300	150	-	-	-	-	510	35.16	215	14.82	290	19.99	128	8.82	290	19.99
1922	1.00	25.4	2.00	50.8	600	150	-	-	-	-	1015	69.98	430	29.64	290	19.99	128	8.82	290	19.99
1924	1.50	38.1	2.00	50.8	900	300	-	-	-	-	1525	105.14	650	44.81	750	51.71	128	8.82	750	51.71
1926	1.50	38.1	2.00	50.8	1500	300	-	-	-	-	2540	175.12	1080	74.46	750	51.71	128	8.82	750	51.71
1928	1.50	38.1	3.00	76.2	2500	300	-	-	-	-	4230	291.64	1800	124.10	750	51.71	128	8.82	750	51.71

Note:

- In 1995 API Changed connections from 2.5 - 3 in.(63.50 -76.20 mm).
For replacement applications, valves with 2.5 in.(63.50mm) connections are still available.

Pressure / Temperature

Selection Chart for Vapors, Gases and Liquids

1900 and 1900-30 Series, D Orifice - API Area: 0.110 in². (0.710 cm²)

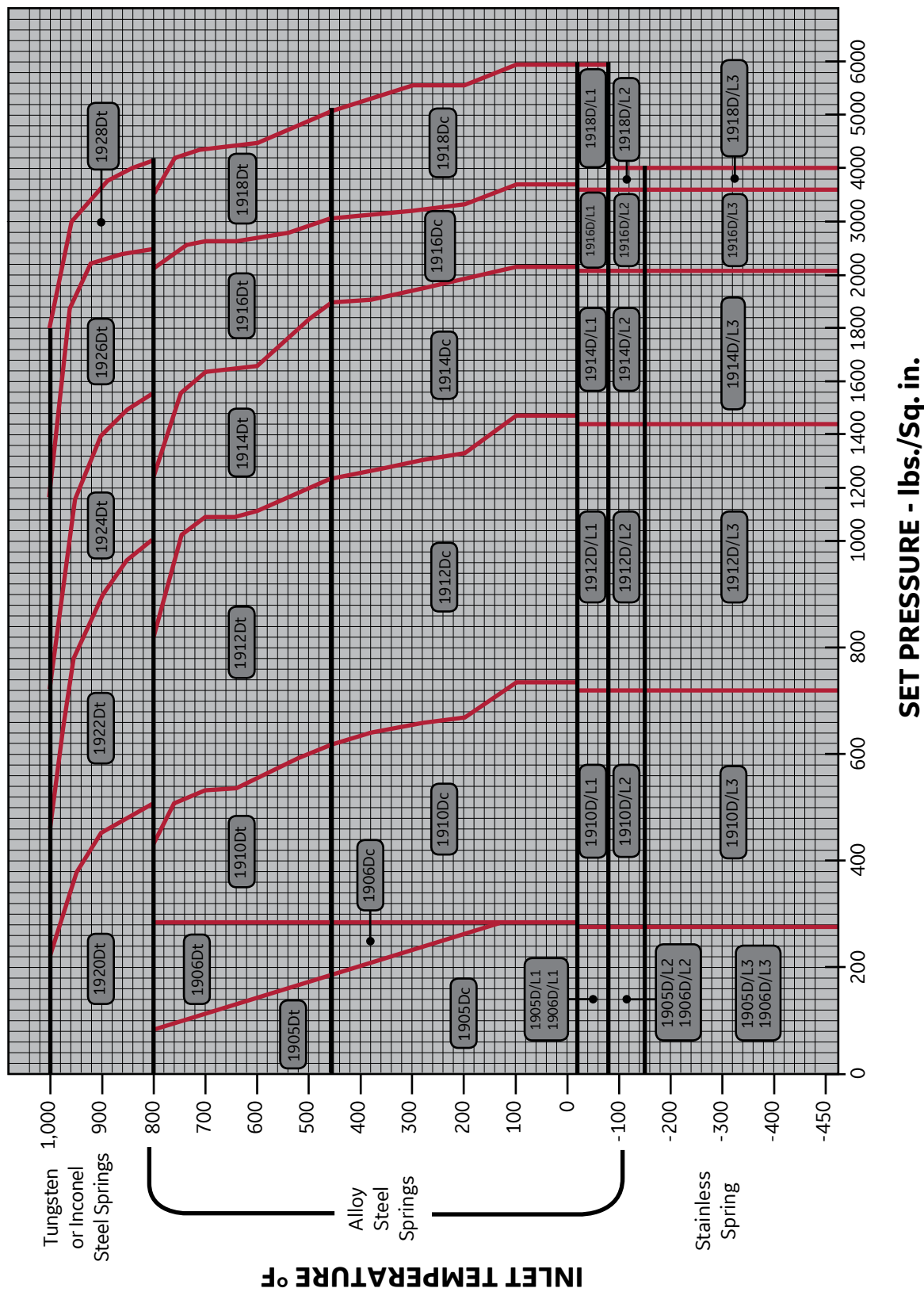

Pressure / Temperature

Pressure Temperature Ratings for E Orifice ¹																				
API Ratings (E Orifice - 0.196 in ² (1.265 cm ²))															Backpressure Ratings @ 100°F (37.8°C)					
Valve Type	Connection				Flanged Ratings		Standard Material of Construction								Conventional		Bellows			
	Inlet		Outlet		Inlet	Outlet	-20 to 100°F (-28.9 to 37.8°C)		450°F (232.2°C)		800°F (426.7°C)		1000°F (537.8°C)				LP		HP	
	in.	mm	in.	mm	R.F. or R.J.	R.F.	psig	barg	psig	barg	psig	barg	psig	barg	psig	barg	psig	barg	psig	barg
1905	1.00	25.4	2.00	50.8	150	150	285	19.65	185	12.75	80	5.51	-	-	285	19.65	128	8.82	230	15.85
1906	1.00	25.4	2.00	50.8	300	150	285	19.65	285	19.65	285	19.65	-	-	285	19.65	128	8.82	230	15.85
1910	1.00	25.4	2.00	50.8	300	150	740	51.02	615	42.40	410	28.26	-	-	285	19.65	128	8.82	230	15.85
1912	1.00	25.4	2.00	50.8	600	150	1480	102.04	1235	85.15	825	56.88	-	-	285	19.65	128	8.82	230	15.85
1914	1.50	38.1	2.00	50.8	900	300	2220	153.06	1845	127.20	1235	85.15	-	-	600	41.36	128	8.82	500	34.47
1916	1.50	38.1	2.00	50.8	1500	300	3705	255.45	3080	212.35	2060	142.03	-	-	600	41.36	128	8.82	500	34.47
1918	1.50	38.1	3.00	76.2	2500	300	6000	413.68	6000	413.68	3430	236.49	-	-	740	51.02	128	8.82	500	34.47
1920	1.00	25.4	2.00	50.8	300	150	-	-	-	-	510	35.16	215	14.82	285	19.65	128	8.82	230	15.85
1922	1.00	25.4	2.00	50.8	600	150	-	-	-	-	1015	69.98	430	29.64	285	19.65	128	8.82	230	15.85
1924	1.50	38.1	2.00	50.8	900	300	-	-	-	-	1525	105.14	650	44.81	600	41.36	128	8.82	500	34.47
1926	1.50	38.1	2.00	50.8	1500	300	-	-	-	-	2540	175.12	1080	74.46	600	41.36	128	8.82	500	34.47
1928	1.50	38.1	3.00	76.2	2500	300	-	-	-	-	4230	291.64	1800	124.10	740	51.02	128	8.82	500	34.47

Pressure Temperature Ratings for E Orifice ¹																				
ASME Ratings (E Orifice - 0.228 in ² (1.470 cm ²) Actual)															Backpressure Ratings @ 100°F (37.8°C)					
Valve Type	Connection				Flanged Ratings		Standard Material of Construction								Conventional		Bellows			
	Inlet		Outlet		Inlet	Outlet	-20 to 100°F (-28.9 to 37.8°C)		450°F (232.2°C)		800°F (426.7°C)		1000°F (537.8°C)				LP		HP	
	in.	mm	in.	mm	R.F. or R.J.	R.F.	psig	barg	psig	barg	psig	barg	psig	barg	psig	barg	psig	barg	psig	barg
1905	1.00	25.4	2.00	50.8	150	150	290	19.99	185	12.75	80	5.51	-	-	290	19.99	128	8.82	290	19.99
1906	1.00	25.4	2.00	50.8	300	150	290	19.99	290	19.99	290	19.99	-	-	290	19.99	128	8.82	290	19.99
1910	1.00	25.4	2.00	50.8	300	150	750	51.71	685	47.22	410	28.26	-	-	290	19.99	128	8.82	290	19.99
1912	1.00	25.4	2.00	50.8	600	150	1500	103.42	1368	94.32	825	56.88	-	-	290	19.99	128	8.82	290	19.99
1914	1.50	38.1	2.00	50.8	900	300	2250	155.13	2053	141.54	1235	85.15	-	-	750	51.71	128	8.82	750	51.71
1916	1.50	38.1	2.00	50.8	1500	300	3750	258.55	3423	236.00	2055	141.68	-	-	750	51.71	128	8.82	750	51.71
1918	1.50	38.1	3.00	76.2	2500	300	6250	430.92	5703	393.20	3430	236.49	-	-	750	51.71	128	8.82	750	51.71
1920	1.00	25.4	2.00	50.8	300	150	-	-	-	-	510	35.16	215	14.82	290	19.99	128	8.82	290	19.99
1922	1.00	25.4	2.00	50.8	600	150	-	-	-	-	1015	69.98	430	29.64	290	19.99	128	8.82	290	19.99
1924	1.50	38.1	2.00	50.8	900	300	-	-	-	-	1525	105.14	650	44.81	750	51.71	128	8.82	750	51.71
1926	1.50	38.1	2.00	50.8	1500	300	-	-	-	-	2540	175.12	1080	74.46	750	51.71	128	8.82	750	51.71
1928	1.50	38.1	3.00	76.2	2500	300	-	-	-	-	4230	291.64	1800	124.10	750	51.71	128	8.82	750	51.71

Note:

- In 1995 API Changed connections from 2.5 - 3 in.(63.50 - 76.20 mm).
For replacement applications, valves with 2.5 in.(63.50mm) connections are still available.

Pressure / Temperature

Selection Chart for Vapors, Gases and Liquids

1900 and 1900-30 Series, E Orifice - API Area: 0.196 in². (1.265 cm²)

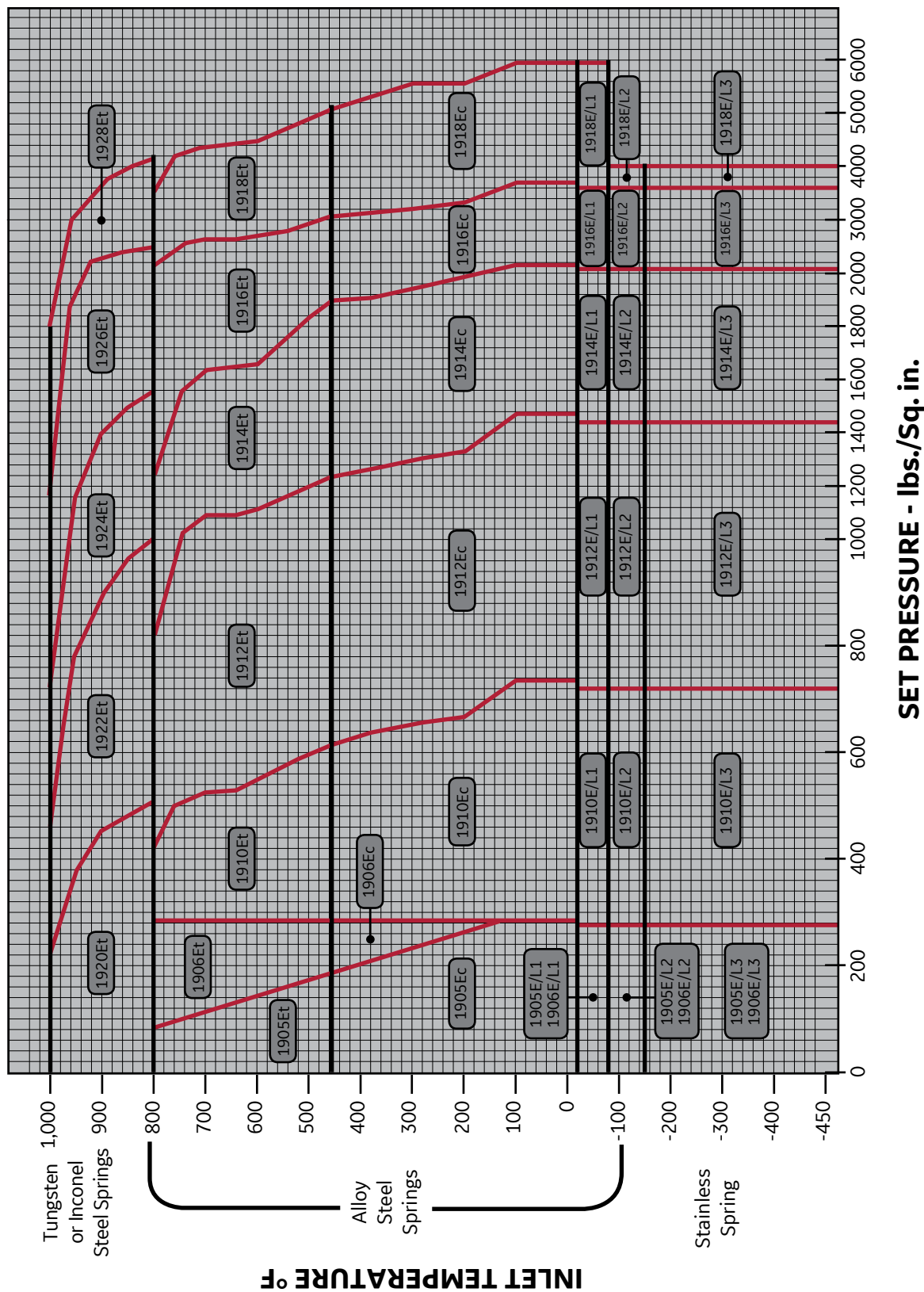

Pressure / Temperature

Pressure Temperature Ratings for F Orifice ¹																				
API Ratings (F Orifice - 0.307 in ² (1.981 cm ²))															Backpressure Ratings @ 100°F (37.8°C)					
Valve Type	Connection				Flanged Ratings		Standard Material of Construction								Conventional		Bellows			
	Inlet		Outlet		Inlet	Outlet	-20 to 100°F (-28.9 to 37.8°C)		450°F (232.2°C)		800°F (426.7°C)		1000°F (537.8°C)				LP		HP	
	in.	mm	in.	mm	R.F. or R.J.	R.F.	psig	barg	psig	barg	psig	barg	psig	barg	psig	barg	psig	barg	psig	barg
1905	1.50	38.1	2.00	50.8	150	150	285	19.65	185	12.75	80	5.51	-	-	285	19.65	128	8.82	230	15.85
1906	1.50	38.1	2.00	50.8	300	150	285	19.65	285	19.65	285	19.65	-	-	285	19.65	128	8.82	230	15.85
1910	1.50	38.1	2.00	50.8	300	150	740	51.02	615	42.40	410	28.26	-	-	285	19.65	128	8.82	230	15.85
1912	1.50	38.1	2.00	50.8	600	150	1480	102.04	1235	85.15	825	56.88	-	-	285	19.65	128	8.82	230	15.85
1914	1.50	38.1	3.00	76.2	900	300	2220	153.06	1845	127.20	1235	85.15	-	-	740	51.02	128	8.82	500	34.47
1916	1.50	38.1	3.00	76.2	1500	300	3705	255.45	3080	212.35	2060	142.03	-	-	740	51.02	128	8.82	500	34.47
1918	1.50	38.1	3.00	76.2	2500	300	5000	344.73	5000	344.73	3430	236.49	-	-	740	51.02	128	8.82	500	34.47
1920	1.50	38.1	2.00	50.8	300	150	-	-	-	-	510	35.16	215	14.82	285	19.65	128	8.82	230	15.85
1922	1.50	38.1	2.00	50.8	600	150	-	-	-	-	1015	69.98	430	29.64	285	19.65	128	8.82	230	15.85
1924	1.50	38.1	3.00	76.2	900	300	-	-	-	-	1525	105.14	650	44.81	740	51.02	128	8.82	500	34.47
1926	1.50	38.1	3.00	76.2	1500	300	-	-	-	-	2540	175.12	1080	74.46	740	51.02	128	8.82	500	34.47
1928	1.50	38.1	3.00	76.2	2500	300	-	-	-	-	4230	291.64	1800	124.10	740	51.02	128	8.82	500	34.47

Pressure Temperature Ratings for F Orifice ¹																				
ASME Ratings (F Orifice - 0.357 in ² (2.302 cm ²) Actual)															Backpressure Ratings @ 100°F (37.8°C)					
Valve Type	Connection				Flanged Ratings		Standard Material of Construction								Conventional		Bellows			
	Inlet		Outlet		Inlet	Outlet	-20 to 100°F (-28.9 to 37.8°C)		450°F (232.2°C)		800°F (426.7°C)		1000°F (537.8°C)				LP		HP	
	in.	mm	in.	mm	R.F. or R.J.	R.F.	psig	barg	psig	barg	psig	barg	psig	barg	psig	barg	psig	barg	psig	barg
1905	1.50	38.1	2.00	50.8	150	150	290	19.99	185	12.75	80	5.51	-	-	290	19.99	128	8.82	290	19.99
1906	1.50	38.1	2.00	50.8	300	150	290	19.99	290	19.99	290	19.99	-	-	290	19.99	128	8.82	290	19.99
1910	1.50	38.1	2.00	50.8	300	150	750	51.71	685	47.22	410	28.26	-	-	290	19.99	128	8.82	290	19.99
1912	1.50	38.1	2.00	50.8	600	150	1500	103.42	1368	94.32	825	56.88	-	-	290	19.99	128	8.82	290	19.99
1914	1.50	38.1	3.00	76.2	900	300	2250	155.13	2053	141.54	1235	85.15	-	-	750	51.71	128	8.82	750	51.71
1916	1.50	38.1	3.00	76.2	1500	300	3750	258.55	3423	236.00	2055	141.68	-	-	750	51.71	128	8.82	750	51.71
1918	1.50	38.1	3.00	76.2	2500	300	6250	430.92	5703	393.20	3430	236.49	-	-	750	51.71	128	8.82	750	51.71
1920	1.50	38.1	2.00	50.8	300	150	-	-	-	-	510	35.16	215	14.82	290	19.99	128	8.82	290	19.99
1922	1.50	38.1	2.00	50.8	600	150	-	-	-	-	1015	69.98	430	29.64	290	19.99	128	8.82	290	19.99
1924	1.50	38.1	3.00	76.2	900	300	-	-	-	-	1525	105.14	650	44.81	750	51.71	128	8.82	750	51.71
1926	1.50	38.1	3.00	76.2	1500	300	-	-	-	-	2540	175.12	1080	74.46	750	51.71	128	8.82	750	51.71
1928	1.50	38.1	3.00	76.2	2500	300	-	-	-	-	4230	291.64	1800	124.10	750	51.71	128	8.82	750	51.71

Note:

- In 1995 API Changed connections from 2.5 - 3 in.(63.50 - 76.20 mm).
For replacement applications, valves with 2.5 in.(63.50mm) connections are still available.

Pressure / Temperature

Selection Chart for Vapors, Gases and Liquids

1900 and 1900-30 Series, F Orifice - API Area: 0.307 in². (1.981 cm²)

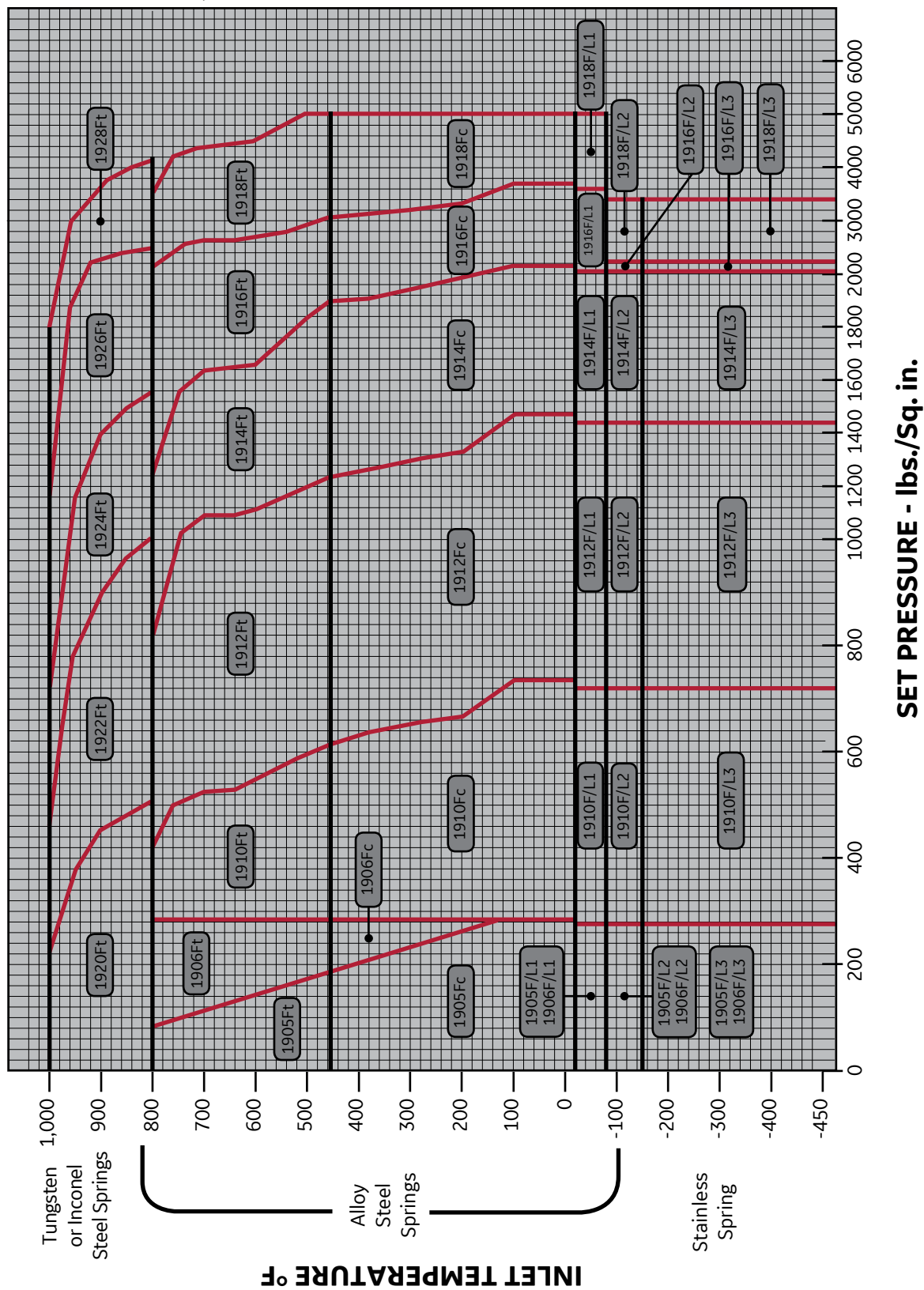

Pressure / Temperature

Pressure Temperature Ratings for G Orifice ¹																				
API Ratings (G Orifice - 0.503 in ² (3.245 cm ²))															Backpressure Ratings @ 100°F (37.8°C)					
Valve Type	Connection				Flanged Ratings		Standard Material of Construction								Conventional		Bellows			
	Inlet		Outlet		Inlet	Outlet	-20 to 100°F (-28.9 to 37.8°C)		450°F (232.2°C)		800°F (426.7°C)		1000°F (537.8°C)				LP		HP	
	in.	mm	in.	mm	R.F. or R.J.	R.F.	psig	barg	psig	barg	psig	barg	psig	barg	psig	barg	psig	barg	psig	barg
1905	1.50	38.1	3.00	76.2	150	150	285	19.65	185	12.75	80	5.51	-	-	285	19.65	140	9.65	230	15.85
1906	1.50	38.1	3.00	76.2	300	150	285	19.65	285	19.65	285	19.65	-	-	285	19.65	140	9.65	230	15.85
1910	1.50	38.1	3.00	76.2	300	150	740	51.02	615	42.40	410	28.26	-	-	285	19.65	140	9.65	230	15.85
1912	1.50	38.1	3.00	76.2	600	150	1480	102.04	1235	85.15	825	56.88	-	-	285	19.65	140	9.65	230	15.85
1914	1.50	38.1	3.00	76.2	900	300	2220	153.06	1845	127.20	1235	85.15	-	-	740	51.02	140	9.65	470	32.40
1916	2.00	50.8	3.00	76.2	1500	300	3705	255.45	3080	212.35	2060	142.03	-	-	740	51.02	140	9.65	470	32.40
1918	2.00	50.8	3.00	76.2	2500	300	3705	413.68	3705	255.45	3430	236.49	-	-	740	51.02	140	9.65	470	32.40
1920	1.50	38.1	3.00	76.2	300	150	-	-	-	-	510	35.16	215	14.82	285	19.65	140	9.65	230	15.85
1922	1.50	38.1	3.00	76.2	600	150	-	-	-	-	1015	69.98	430	29.64	285	19.65	140	9.65	230	15.85
1924	1.50	38.1	3.00	76.2	900	300	-	-	-	-	1525	105.14	650	44.81	740	51.02	140	9.65	500	34.47
1926	2.00	50.8	3.00	76.2	1500	300	-	-	-	-	2540	175.12	1080	74.46	740	51.02	140	9.65	500	34.47
1928	2.00	50.8	3.00	76.2	2500	300	-	-	-	-	3705	255.45	1800	124.10	740	51.02	140	9.65	500	34.47

Pressure Temperature Ratings for G Orifice ¹																				
ASME Ratings (G Orifice - 0.585 in ² (3.774 cm ²) Actual)															Backpressure Ratings @ 100°F (37.8°C)					
Valve Type	Connection				Flanged Ratings		Standard Material of Construction								Conventional		Bellows			
	Inlet		Outlet		Inlet	Outlet	-20 to 100°F (-28.9 to 37.8°C)		450°F (232.2°C)		800°F (426.7°C)		1000°F (537.8°C)				LP		HP	
	in.	mm	in.	mm	R.F. or R.J.	R.F.	psig	barg	psig	barg	psig	barg	psig	barg	psig	barg	psig	barg	psig	barg
1905	1.50	38.1	3.00	76.2	150	150	290	19.99	185	12.75	80	5.51	-	-	290	19.99	140	9.65	290	19.99
1906	1.50	38.1	3.00	76.2	300	150	290	19.99	290	19.99	290	19.99	-	-	290	19.99	140	9.65	290	19.99
1910	1.50	38.1	3.00	76.2	300	150	750	51.71	685	47.22	410	28.26	-	-	290	19.99	140	9.65	290	19.99
1912	1.50	38.1	3.00	76.2	600	150	1500	103.42	1368	94.32	825	56.88	-	-	290	19.99	140	9.65	290	19.99
1914	1.50	38.1	3.00	76.2	900	300	2250	155.13	2053	141.54	1235	85.15	-	-	750	51.71	140	9.65	750	51.71
1916	2.00	50.8	3.00	76.2	1500	300	3750	258.55	3423	236.00	2055	141.68	-	-	750	51.71	140	9.65	750	51.71
1918	2.00	50.8	3.00	76.2	2500	300	5000	344.73	5000	344.73	3430	236.49	-	-	750	51.71	140	9.65	750	51.71
1920	1.50	38.1	3.00	76.2	300	150	-	-	-	-	510	35.16	215	14.82	290	19.99	140	9.65	290	19.99
1922	1.50	38.1	3.00	76.2	600	150	-	-	-	-	1015	69.98	430	29.64	290	19.99	140	9.65	290	19.99
1924	1.50	38.1	3.00	76.2	900	300	-	-	-	-	1525	105.14	650	44.81	750	51.71	140	9.65	750	51.71
1926	2.00	50.8	3.00	76.2	1500	300	-	-	-	-	2540	175.12	1080	74.46	750	51.71	140	9.65	750	51.71
1928	2.00	50.8	3.00	76.2	2500	300	-	-	-	-	4230	291.64	1800	124.10	750	51.71	140	9.65	750	51.71

Note:

1. In 1995 API Changed connections from 2.5 - 3 in.(63.50 -76.20 mm).
For replacement applications, valves with 2.5 in.(63.50mm) connections are still available.

Pressure / Temperature

Selection Chart for Vapors, Gases and Liquids
 1900 and 1900-30 Series, G Orifice - API Area: 0.503 in². (3.245 cm²)

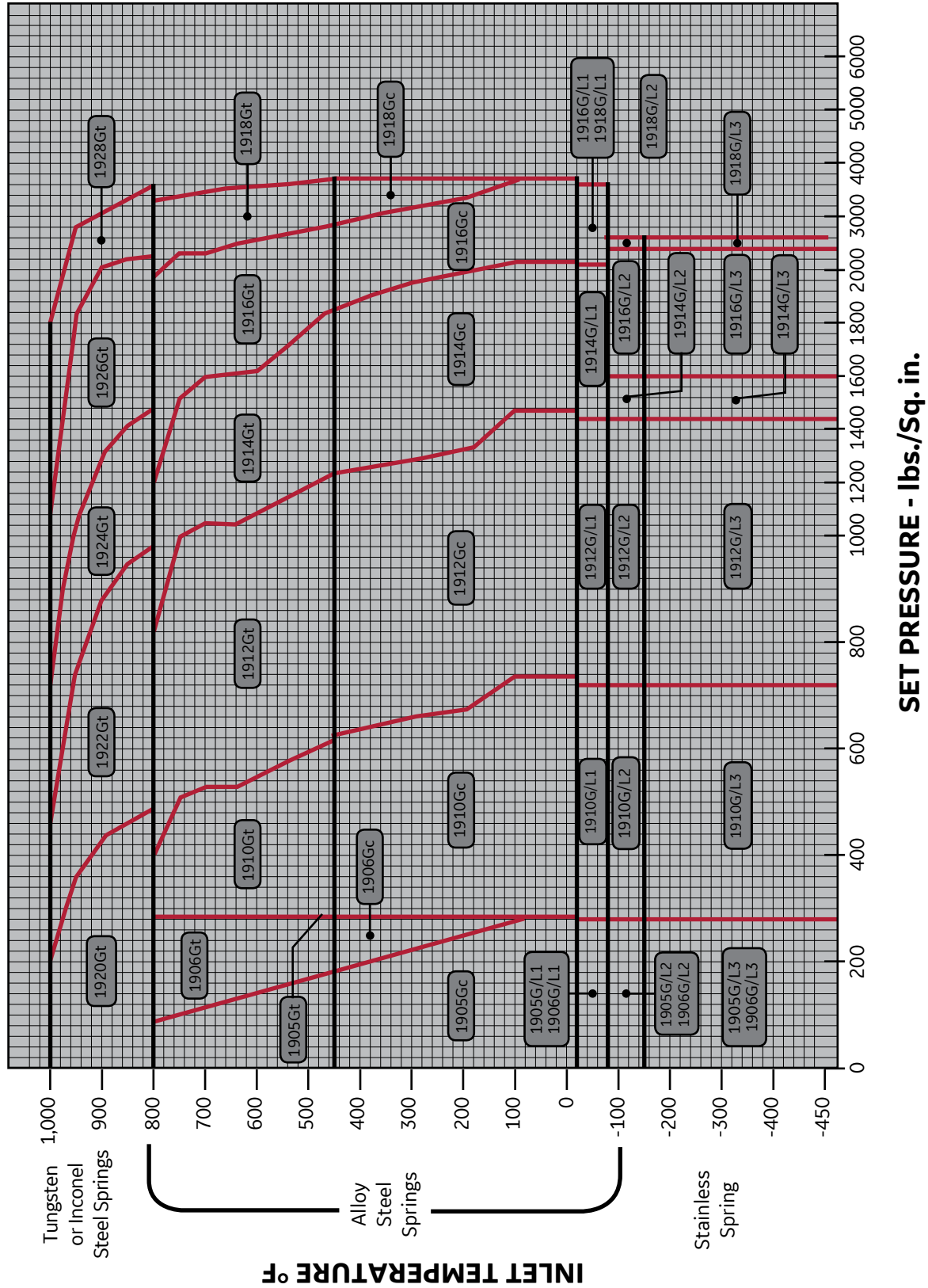

Pressure / Temperature

Pressure Temperature Ratings for H Orifice																				
API Ratings (H Orifice - 0.785 in ² (5.065 cm ²))															Backpressure Ratings @ 100°F (37.8°C)					
Valve Type	Connection				Flanged Ratings		Standard Material of Construction								Conventional		Bellows			
	Inlet		Outlet		Inlet	Outlet	-20 to 100°F (-28.9 to 37.8°C)		450°F (232.2°C)		800°F (426.7°C)		1000°F (537.8°C)				LP		HP	
	in.	mm	in.	mm	R.F. or R.J.	R.F.	psig	barg	psig	barg	psig	barg	psig	barg	psig	barg	psig	barg	psig	barg
1905	1.50	38.1	3.00	76.2	150	150	285	19.65	185	12.75	80	5.51	-	-	285	19.65	104	7.17	230	15.85
1906	1.50	38.1	3.00	76.2	300	150	285	19.65	285	19.65	285	19.65	-	-	285	19.65	104	7.17	230	15.85
1910	2.00	50.8	3.00	76.2	300	150	740	51.02	615	42.40	410	28.26	-	-	285	19.65	104	7.17	230	15.85
1912	2.00	50.8	3.00	76.2	600	150	1480	102.04	1235	85.15	825	56.88	-	-	285	19.65	104	7.17	230	15.85
1914	2.00	50.8	3.00	76.2	900	300	2220	153.06	1845	127.20	1235	85.15	-	-	285	19.65	104	7.17	230	15.85
1916	2.00	50.8	3.00	76.2	1500	300	2750	189.60	2750	189.60	2060	142.03	-	-	740	51.02	104	7.17	415	28.61
1920	2.00	50.8	3.00	76.2	300	150	-	-	-	-	510	35.16	215	14.82	285	19.65	104	7.17	230	15.85
1922	2.00	50.8	3.00	76.2	600	150	-	-	-	-	1015	69.98	430	29.64	285	19.65	104	7.17	230	15.85
1924	2.00	50.8	3.00	76.2	900	300	-	-	-	-	1225	84.46	650	44.81	285	19.65	104	7.17	230	15.85
1926	2.00	50.8	3.00	76.2	1500	300	-	-	-	-	2540	175.12	1080	74.46	740	51.02	104	7.17	415	28.61

Pressure Temperature Ratings for H Orifice																				
ASME Ratings (H Orifice - 0.913 in ² (5.888 cm ²) Actual)															Backpressure Ratings @ 100°F (37.8°C)					
Valve Type	Connection				Flanged Ratings		Standard Material of Construction								Conventional		Bellows			
	Inlet		Outlet		Inlet	Outlet	-20 to 100°F (-28.9 to 37.8°C)		450°F (232.2°C)		800°F (426.7°C)		1000°F (537.8°C)				LP		HP	
	in.	mm	in.	mm	R.F. or R.J.	R.F.	psig	barg	psig	barg	psig	barg	psig	barg	psig	barg	psig	barg	psig	barg
1905	1.50	38.1	3.00	76.2	150	150	290	19.99	185	12.75	80	5.51	-	-	290	19.99	104	7.17	290	19.99
1906	1.50	38.1	3.00	76.2	300	150	290	19.99	290	19.99	290	19.99	-	-	290	19.99	104	7.17	290	19.99
1910	2.00	50.8	3.00	76.2	300	150	750	51.71	685	47.22	410	28.26	-	-	290	19.99	104	7.17	290	19.99
1912	2.00	50.8	3.00	76.2	600	150	1500	103.42	1368	94.32	825	56.88	-	-	290	19.99	104	7.17	290	19.99
1914	2.00	50.8	3.00	76.2	900	300	2250	155.13	2053	141.54	1235	85.15	-	-	290	19.99	104	7.17	750	51.71
1916	2.00	50.8	3.00	76.2	1500	300	3300	227.52	3300	227.52	2055	141.68	-	-	750	51.71	104	7.17	750	51.71
1920	2.00	50.8	3.00	76.2	300	150	-	-	-	-	510	35.16	215	14.82	290	19.99	104	7.17	750	51.71
1922	2.00	50.8	3.00	76.2	600	150	-	-	-	-	1015	69.98	430	29.64	290	19.99	104	7.17	290	19.99
1924	2.00	50.8	3.00	76.2	900	300	-	-	-	-	1525	105.14	650	44.81	290	19.99	104	7.17	290	19.99
1926	2.00	50.8	3.00	76.2	1500	300	-	-	-	-	2540	175.12	1080	74.46	750	51.71	104	7.17	750	51.71

Pressure / Temperature

Selection Chart for Vapors, Gases and Liquids

1900 and 1900-30 Series, H Orifice - API Area: 0.785 in². (5.065 cm²)

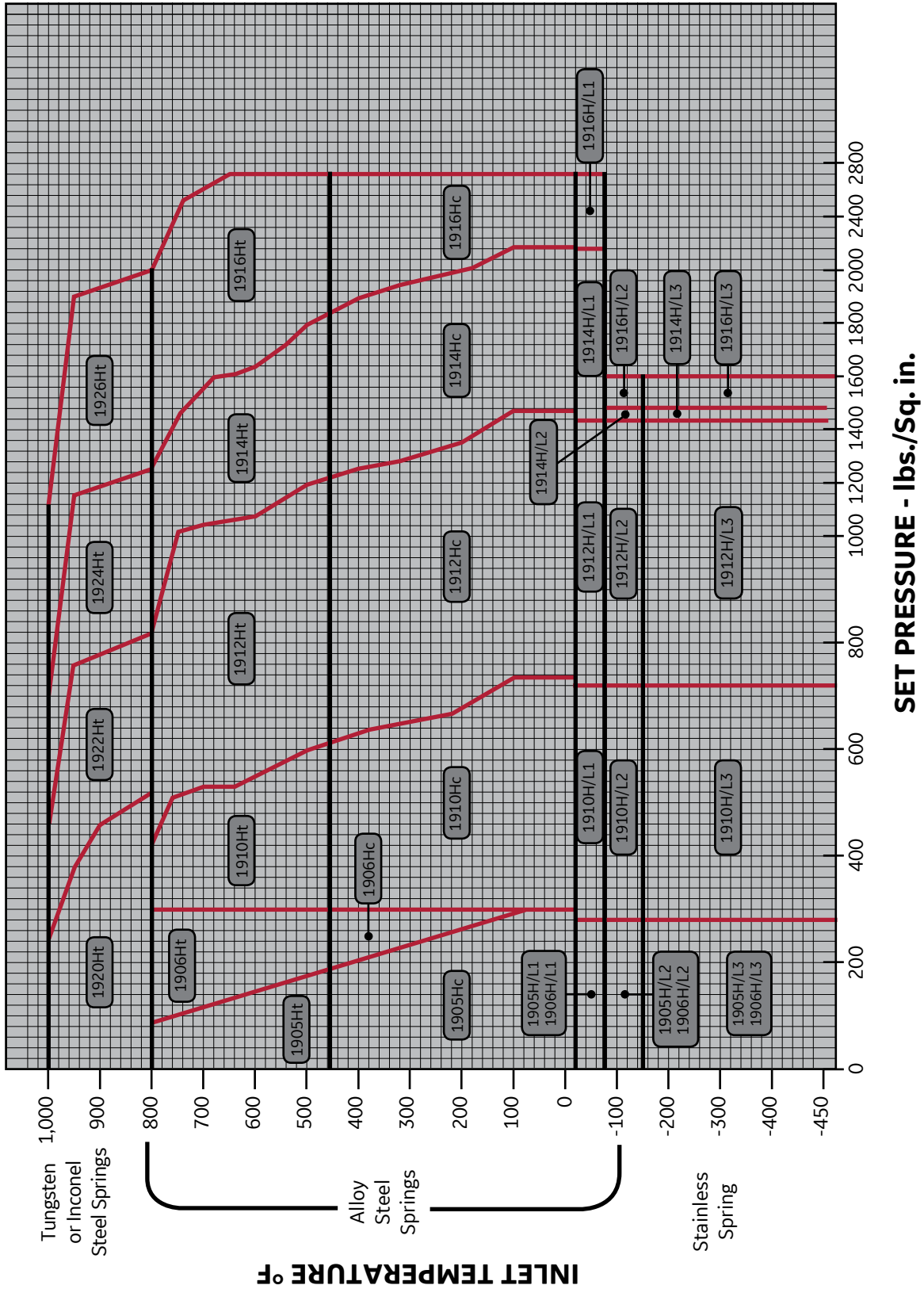

Pressure / Temperature

Pressure Temperature Ratings for J Orifice ¹																				
API Ratings (J Orifice - 1.287 in ² (8.303 cm ²))														Backpressure Ratings @ 100°F (37.8°C)						
Valve Type	Connection				Flanged Ratings		Standard Material of Construction								Conventional		Bellows			
	Inlet		Outlet		Inlet	Outlet	-20 to 100°F (-28.9 to 37.8°C)		450°F (232.2°C)		800°F (426.7°C)		1000°F (537.8°C)				LP		HP	
	in.	mm	in.	mm	R.F. or R.J.	R.F.	psig	barg	psig	barg	psig	barg	psig	barg	psig	barg	psig	barg	psig	barg
1905	2.00	50.8	3.00	76.2	150	150	285	19.65	185	12.75	80	5.51	-	-	285	19.65	89	6.13	230	15.85
1906	2.00	50.8	3.00	76.2	300	150	285	19.65	285	19.65	285	19.65	-	-	285	19.65	89	6.13	230	15.85
1910	3.00	76.2	4.00	101.6	300	150	740	51.02	615	42.40	410	28.26	-	-	285	19.65	89	6.13	230	15.85
1912	3.00	76.2	4.00	101.6	600	150	1480	102.04	1235	85.15	825	56.88	-	-	285	19.65	89	6.13	230	15.85
1914	3.00	76.2	4.00	101.6	900	300	2220	153.06	1845	127.20	1235	85.15	-	-	285	19.65	89	6.13	230	15.85
1916	3.00	76.2	4.00	101.6	1500	300	2700	186.15	2700	186.15	2060	142.03	-	-	600	41.36	89	6.13	230	15.85
1920	3.00	76.2	4.00	101.6	300	150	-	-	-	-	510	35.16	215	14.82	285	19.65	89	6.13	230	15.85
1922	3.00	76.2	4.00	101.6	600	150	-	-	-	-	1015	69.98	430	29.64	285	19.65	89	6.13	230	15.85
1924	3.00	76.2	4.00	101.6	900	300	-	-	-	-	1525	105.14	650	44.81	285	19.65	89	6.13	230	15.85
1926	3.00	76.2	4.00	101.6	1500	300	-	-	-	-	2540	175.12	1080	74.46	600	41.36	89	6.13	230	15.85

Pressure Temperature Ratings for J Orifice ¹																				
ASME Ratings (J Orifice - 1.496 in ² (9.652 cm ²) Actual)														Backpressure Ratings @ 100°F (37.8°C)						
Valve Type	Connection				Flanged Ratings		Standard Material of Construction								Conventional		Bellows			
	Inlet		Outlet		Inlet	Outlet	-20 to 100°F (-28.9 to 37.8°C)		450°F (232.2°C)		800°F (426.7°C)		1000°F (537.8°C)				LP		HP	
	in.	mm	in.	mm	R.F. or R.J.	R.F.	psig	barg	psig	barg	psig	barg	psig	barg	psig	barg	psig	barg	psig	barg
1905	2.00	50.8	3.00	76.2	150	150	290	19.99	185	12.75	80	5.51	-	-	290	19.99	89	6.13	290	19.99
1906	2.00	50.8	3.00	76.2	300	150	290	19.99	290	19.99	290	19.99	-	-	290	19.99	89	6.13	290	19.99
1910	3.00	76.2	4.00	101.6	300	150	750	51.71	685	47.22	410	28.26	-	-	290	19.99	89	6.13	290	19.99
1912	3.00	76.2	4.00	101.6	600	150	1500	103.42	1368	94.32	825	56.88	-	-	290	19.99	89	6.13	290	19.99
1914	3.00	76.2	4.00	101.6	900	300	2250	155.13	2053	141.54	1235	85.15	-	-	290	19.99	89	6.13	290	19.99
1916	3.00	76.2	4.00	101.6	1500	300	3100	213.73	3100	213.73	2055	141.68	-	-	750	51.71	89	6.13	635	43.78
1920	3.00	76.2	4.00	101.6	300	150	-	-	-	-	510	35.16	215	14.82	290	19.99	89	6.13	290	19.99
1922	3.00	76.2	4.00	101.6	600	150	-	-	-	-	1015	69.98	430	29.64	290	19.99	89	6.13	290	19.99
1924	3.00	76.2	4.00	101.6	900	300	-	-	-	-	1525	105.14	650	44.81	290	19.99	89	6.13	290	19.99
1926	3.00	76.2	4.00	101.6	1500	300	-	-	-	-	2540	175.12	1080	74.46	750	51.71	89	6.13	635	43.78

Note:

- In 1995 API Changed connections from 2.5 - 3 in.(63.50 -76.20 mm).
For replacement applications, valves with 2.5 in.(63.50mm) connections are still available.

Pressure / Temperature

Selection Chart for Vapors, Gases and Liquids

1900 and 1900-30 Series, J Orifice - API Area: 1.287 in². (8.303 cm²)

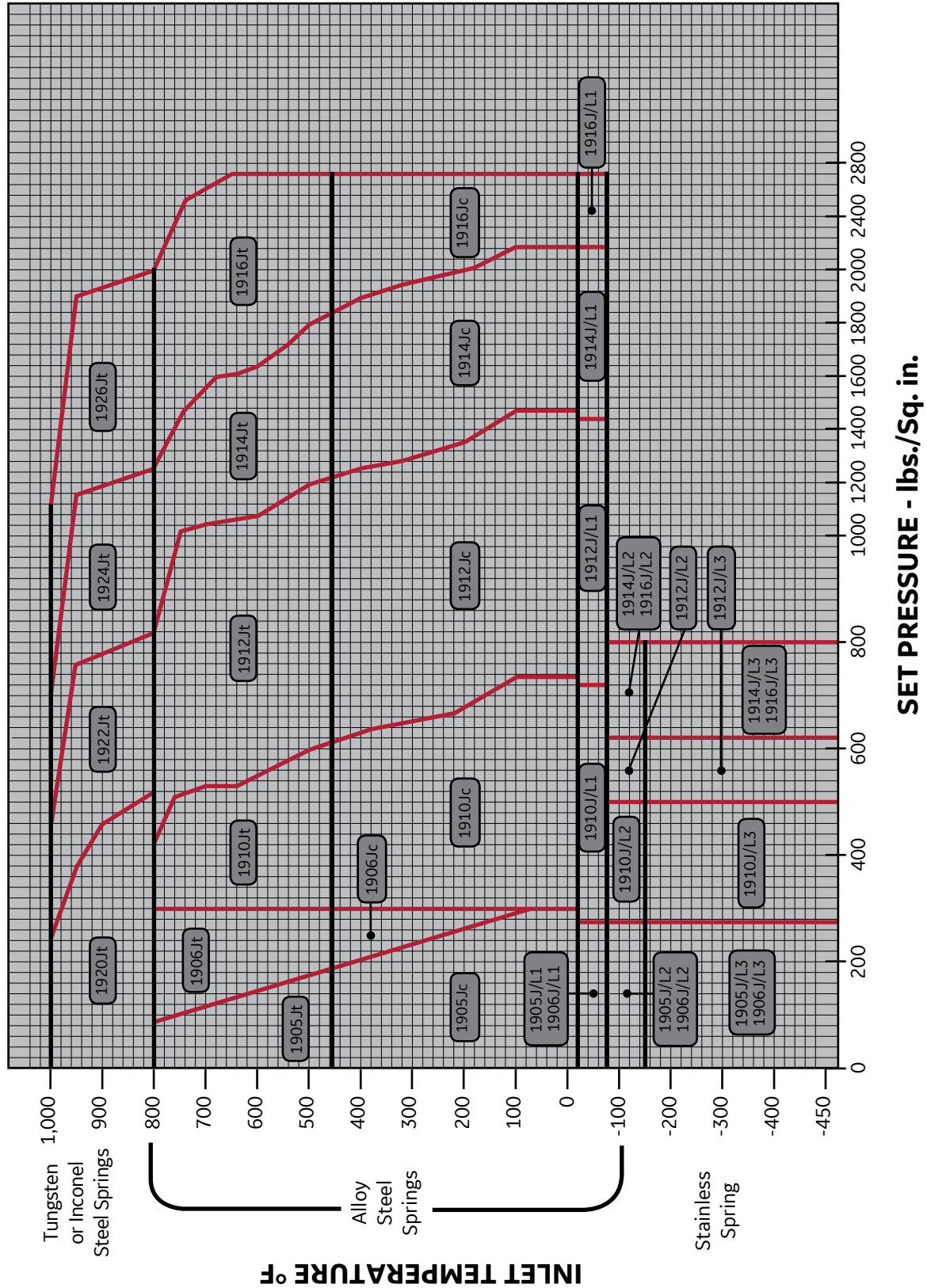

Pressure / Temperature

Pressure Temperature Ratings for K Orifice ¹																				
API Ratings (K Orifice - 1.838 in ² (11.858 cm ²))															Backpressure Ratings @ 100°F (37.8°C)					
Valve Type	Connection				Flanged Ratings		Standard Material of Construction								Conventional		Bellows			
	Inlet		Outlet		Inlet	Outlet	-20 to 100°F (-28.9 to 37.8°C)		450°F (232.2°C)		800°F (426.7°C)		1000°F (537.8°C)				LP		HP	
	in.	mm	in.	mm	R.F. or R.J.	R.F.	psig	barg	psig	barg	psig	barg	psig	barg	psig	barg	psig	barg	psig	barg
1905	3.00	76.2	4.00	101.6	150	150	285	19.65	185	12.75	80	5.51	-	-	285	19.65	65	4.48	150	10.34
1906	3.00	76.2	4.00	101.6	300	150	285	19.65	285	19.65	285	19.65	-	-	285	19.65	65	4.48	150	10.34
1910	3.00	76.2	4.00	101.6	300	150	740	51.02	615	42.40	410	28.26	-	-	285	19.65	65	4.48	150	10.34
1912	3.00	76.2	4.00	101.6	600	150	1480	102.04	1235	85.15	825	56.88	-	-	285	19.65	65	4.48	200	13.78
1914	3.00	76.2	6.00	152.4	900	300	2220	153.06	1845	127.20	1235	85.15	-	-	285	19.65	65	4.48	200	13.78
1916	3.00	76.2	6.00	152.4	1500	300	2220	153.06	2220	153.06	2060	142.03	-	-	600	41.36	65	4.48	200	13.78
1920	3.00	76.2	4.00	101.6	300	150	-	-	-	-	510	35.16	215	14.82	285	19.65	65	4.48	230	15.85
1922	3.00	76.2	4.00	101.6	600	150	-	-	-	-	1015	69.98	430	29.64	285	19.65	65	4.48	230	15.85
1924	3.00	76.2	6.00	152.4	900	300	-	-	-	-	1525	105.14	650	44.81	285	19.65	65	4.48	230	15.85
1926	3.00	76.2	6.00	152.4	1500	300	-	-	-	-	2220	153.06	1080	74.46	600	41.36	65	4.48	230	15.85

Pressure Temperature Ratings for K Orifice ¹																				
ASME Ratings (K Orifice - 2.138 in ² (13.794 cm ²) Actual)															Backpressure Ratings @ 100°F (37.8°C)					
Valve Type	Connection				Flanged Ratings		Standard Material of Construction								Conventional		Bellows			
	Inlet		Outlet		Inlet	Outlet	-20 to 100°F (-28.9 to 37.8°C)		450°F (232.2°C)		800°F (426.7°C)		1000°F (537.8°C)				LP		HP	
	in.	mm	in.	mm	R.F. or R.J.	R.F.	psig	barg	psig	barg	psig	barg	psig	barg	psig	barg	psig	barg	psig	barg
1905	3.00	76.2	4.00	101.6	150	150	290	19.99	185	12.75	80	5.51	-	-	290	19.99	89	6.13	290	19.99
1906	3.00	76.2	4.00	101.6	300	150	290	19.99	290	19.99	290	19.99	-	-	290	19.99	89	6.13	290	19.99
1910	3.00	76.2	4.00	101.6	300	150	750	51.71	685	47.22	410	28.26	-	-	290	19.99	89	6.13	290	19.99
1912	3.00	76.2	4.00	101.6	600	150	1500	103.42	1368	94.32	825	56.88	-	-	290	19.99	89	6.13	290	19.99
1914	3.00	76.2	6.00	152.4	900	300	2250	155.13	2053	141.54	1235	85.15	-	-	290	19.99	89	6.13	290	19.99
1916	3.00	76.2	6.00	152.4	1500	300	3000	206.84	3000	206.84	2055	141.68	-	-	750	51.71	89	6.13	535	36.88
1920	3.00	76.2	4.00	101.6	300	150	-	-	-	-	510	35.16	215	14.82	290	19.99	89	6.13	290	19.99
1922	3.00	76.2	4.00	101.6	600	150	-	-	-	-	1015	69.98	430	29.64	290	19.99	89	6.13	290	19.99
1924	3.00	76.2	6.00	152.4	900	300	-	-	-	-	1525	105.14	650	44.81	290	19.99	89	6.13	290	19.99
1926	3.00	76.2	6.00	152.4	1500	300	-	-	-	-	2540	175.12	1080	74.46	750	51.71	89	6.13	535	36.88

Note:

1. In 1995 API Changed connections from 2.5 - 3 in.(63.50 - 76.20 mm).
For replacement applications, valves with 2.5 in.(63.50mm) connections are still available.

Pressure / Temperature

Selection Chart for Vapors, Gases and Liquids
 1900 and 1900-30 Series, K Orifice - API Area: 1.838 in². (11.858 cm²)

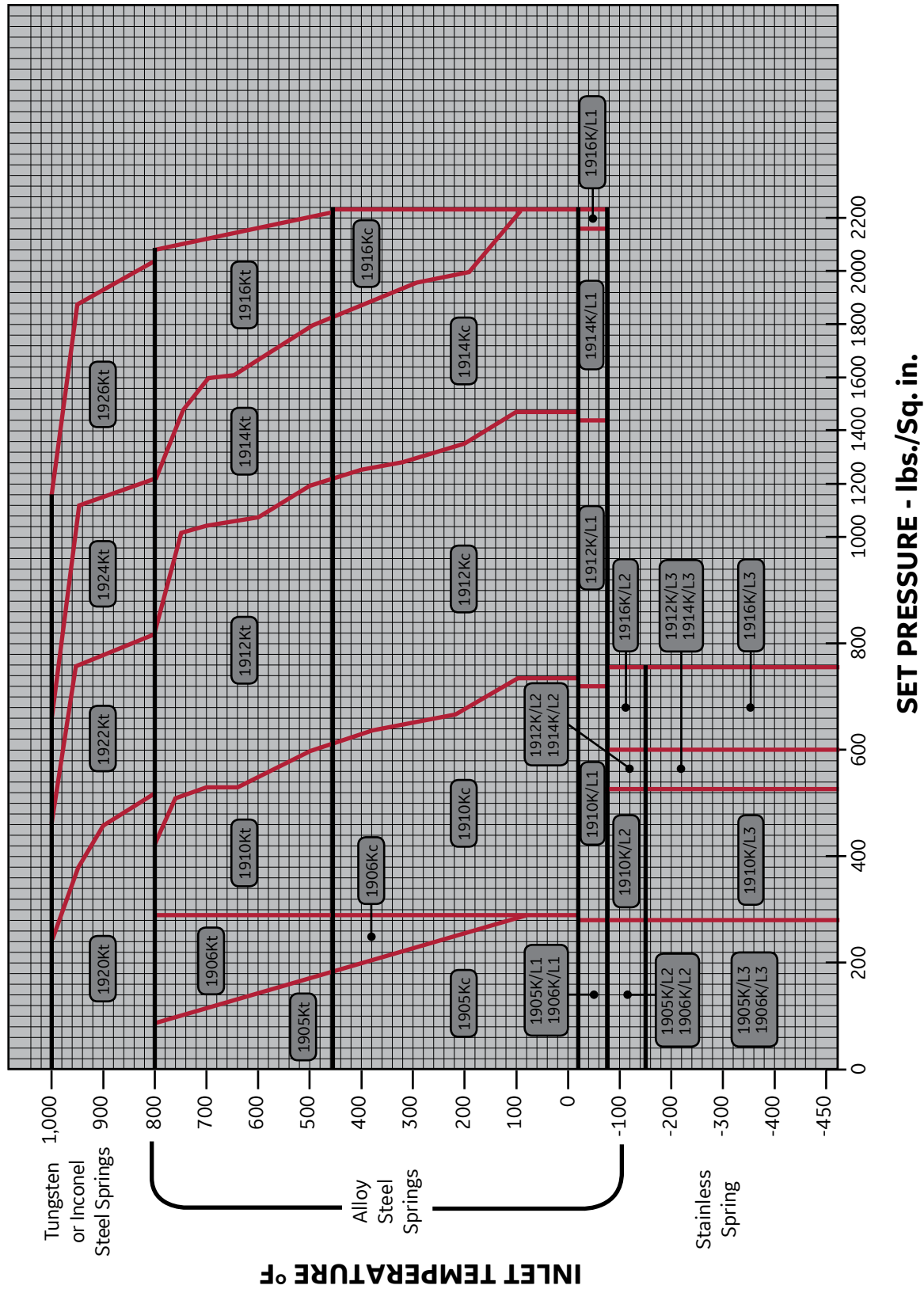

Pressure / Temperature

Pressure Temperature Ratings for L Orifice																					
API Ratings (L Orifice - 2.853 in ² (18.406 cm ²))															Backpressure Ratings @ 100°F (37.8°C)						
Valve Type	Connection				Flanged Ratings		Standard Material of Construction								Conventional		Bellows				
	Inlet		Outlet		Inlet	Outlet	-20 to 100°F (-28.9 to 37.8°C)		450°F (232.2°C)		800°F (426.7°C)		1000°F (537.8°C)				LP		HP		
	in.	mm	in.	mm	R.F. or R.J.	R.F.	psig	barg	psig	barg	psig	barg	psig	barg	psig	barg	psig	barg	psig	barg	
1905	3.00	76.2	4.00	101.6	150	150	285	19.65	185	12.75	80	5.51	-	-	285	19.65	53	3.65	100	6.89	
1906	3.00	76.2	4.00	101.6	300	150	285	19.65	285	19.65	285	19.65	-	-	285	19.65	53	3.65	100	6.89	
1910	4.00	101.6	6.00	152.4	300	150	740	51.02	615	42.40	410	28.26	-	-	285	19.65	53	3.65	170	11.72	
1912	4.00	101.6	6.00	152.4	600	150	1000	68.94	1000	68.94	825	56.88	-	-	285	19.65	53	3.65	170	11.72	
1914	4.00	101.6	6.00	152.4	900	300	1500	103.42	1500	103.42	1235	85.15	-	-	285	19.65	53	3.65	170	11.72	
1916	4.00	101.6	6.00	152.4	1500	300	1500	103.42	1500	103.42	1500	103.42	-	-	285	19.65	53	3.65	170	11.72	
1920	4.00	101.6	6.00	152.4	300	150	-	-	-	-	510	35.16	215	14.82	285	19.65	53	3.65	170	11.72	
1922	4.00	101.6	6.00	152.4	600	150	-	-	-	-	1000	68.94	430	29.64	285	19.65	53	3.65	170	11.72	
1924	4.00	101.6	6.00	152.4	900	300	-	-	-	-	1500	103.42	650	44.81	285	19.65	53	3.65	170	11.72	
1926	4.00	101.6	6.00	152.4	1500	300	-	-	-	-	1500	103.42	1080	74.46	600	41.36	53	3.65	170	11.72	

Pressure Temperature Ratings for L Orifice																					
ASME Ratings (L Orifice - 3.317 in ² (21.400 cm ²) Actual)															Backpressure Ratings @ 100°F (37.8°C)						
Valve Type	Connection				Flanged Ratings		Standard Material of Construction								Conventional		Bellows				
	Inlet		Outlet		Inlet	Outlet	-20 to 100°F (-28.9 to 37.8°C)		450°F (232.2°C)		800°F (426.7°C)		1000°F (537.8°C)				LP		HP		
	in.	mm	in.	mm	R.F. or R.J.	R.F.	psig	barg	psig	barg	psig	barg	psig	barg	psig	barg	psig	barg	psig	barg	
1905	3.00	76.2	4.00	101.6	150	150	290	19.99	185	12.75	80	5.51	-	-	290	19.99	53	3.65	290	19.99	
1906	3.00	76.2	4.00	101.6	300	150	290	19.99	290	19.99	290	19.99	-	-	290	19.99	53	3.65	290	19.99	
1910	4.00	101.6	6.00	152.4	300	150	750	51.71	685	47.22	410	28.26	-	-	290	19.99	53	3.65	290	19.99	
1912	4.00	101.6	6.00	152.4	600	150	1500	103.42	1368	94.32	825	56.88	-	-	290	19.99	53	3.65	290	19.99	
1914	4.00	101.6	6.00	152.4	900	300	2250	155.13	2053	141.54	1235	85.15	-	-	290	19.99	53	3.65	290	19.99	
1916	4.00	101.6	6.00	152.4	1500	300	3000	206.84	3000	206.84	2055	141.68	-	-	290	19.99	53	3.65	535	36.88	
1920	4.00	101.6	6.00	152.4	300	150	-	-	-	-	510	35.16	215	14.82	290	19.99	53	3.65	290	19.99	
1922	4.00	101.6	6.00	152.4	600	150	-	-	-	-	1015	69.98	430	29.64	290	19.99	53	3.65	290	19.99	
1924	4.00	101.6	6.00	152.4	900	300	-	-	-	-	1525	105.14	650	44.81	290	19.99	53	3.65	290	19.99	
1926	4.00	101.6	6.00	152.4	1500	300	-	-	-	-	2540	175.12	1080	74.46	290	19.99	53	3.65	535	36.88	

Pressure / Temperature

Selection Chart for Vapors, Gases and Liquids
1900 and 1900-30 Series, L Orifice - API Area: 2.853 in². (18.406 cm²)

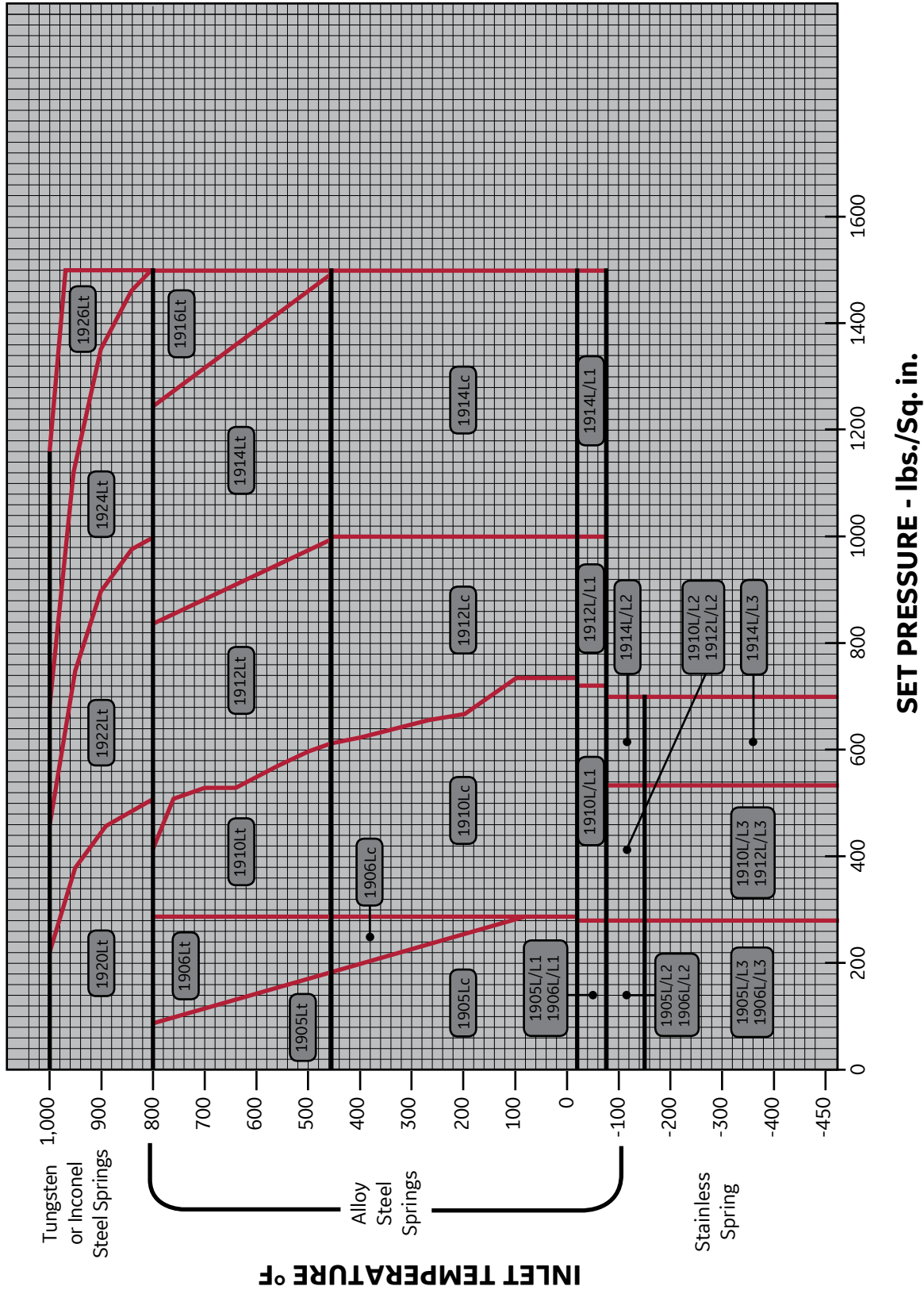

Pressure / Temperature

Pressure Temperature Ratings for M Orifice¹

API Ratings (M Orifice - 3.600 in ² (23.226 cm ²))																				Backpressure Ratings @ 100°F (37.8°C)			
Valve Type	Connection				Flanged Ratings		Standard Material of Construction								Conventional		Bellows						
	Inlet		Outlet		Inlet	Outlet	-20 to 100°F (-28.9 to 37.8°C)		450°F (232.2°C)		800°F (426.7°C)		1000°F (537.8°C)				LP		HP				
	in.	mm	in.	mm	R.F. or R.J.	R.F.	psig	barg	psig	barg	psig	barg	psig	barg	psig	barg	psig	barg	psig	barg			
1905	4.00	101.6	6.00	152.4	150	150	285	19.65	185	12.75	80	5.51	-	-	285	19.65	66	4.55	80	5.51			
1906	4.00	101.6	6.00	152.4	300	150	285	19.65	285	19.65	285	19.65	-	-	285	19.65	66	4.55	80	5.51			
1910	4.00	101.6	6.00	152.4	300	150	740	51.02	615	42.40	410	28.26	-	-	285	19.65	66	4.55	160	11.03			
1912	4.00	101.6	6.00	152.4	600	150	1100	75.84	1100	75.84	825	56.88	-	-	285	19.65	66	4.55	160	11.03			
1914	4.00	101.6	6.00	152.4	900	300	1100	75.84	1100	75.84	1100	75.84	-	-	285	19.65	66	4.55	160	11.03			
1920	4.00	101.6	6.00	152.4	300	150	-	-	-	-	510	35.16	215	14.82	285	19.65	66	4.55	160	11.03			
1922	4.00	101.6	6.00	152.4	600	150	-	-	-	-	1000	68.94	430	29.64	285	19.65	66	4.55	160	11.03			
1924	4.00	101.6	6.00	152.4	900	300	-	-	-	-	1100	75.84	650	44.81	285	19.65	66	4.55	160	11.03			

Pressure Temperature Ratings for M Orifice¹

ASME Ratings (M Orifice - 4.186 in ² (27.006 cm ²) Actual)																				Backpressure Ratings @ 100°F (37.8°C)			
Valve Type	Connection				Flanged Ratings		Standard Material of Construction								Conventional		Bellows						
	Inlet		Outlet		Inlet	Outlet	-20 to 100°F (-28.9 to 37.8°C)		450°F (232.2°C)		800°F (426.7°C)		1000°F (537.8°C)				LP		HP				
	in.	mm	in.	mm	R.F. or R.J.	R.F.	psig	barg	psig	barg	psig	barg	psig	barg	psig	barg	psig	barg	psig	barg			
1905	4.00	101.6	6.00	152.4	150	150	290	19.99	185	12.75	80	5.51	-	-	290	19.99	66	4.55	290	19.99			
1906	4.00	101.6	6.00	152.4	300	150	290	19.99	290	19.99	290	19.99	-	-	290	19.99	66	4.55	290	19.99			
1910	4.00	101.6	6.00	152.4	300	150	750	51.71	685	47.22	410	28.26	-	-	290	19.99	66	4.55	290	19.99			
1912	4.00	101.6	6.00	152.4	600	150	1500	103.42	1368	94.32	825	56.88	-	-	290	19.99	66	4.55	290	19.99			
1914	4.00	101.6	6.00	152.4	900	300	1600	110.31	1600	110.31	1235	85.15	-	-	290	19.99	66	4.55	290	19.99			
1920	4.00	101.6	6.00	152.4	300	150	-	-	-	-	510	35.16	215	14.82	290	19.99	66	4.55	290	19.99			
1922	4.00	101.6	6.00	152.4	600	150	-	-	-	-	1015	69.98	430	29.64	290	19.99	66	4.55	290	19.99			
1924	4.00	101.6	6.00	152.4	900	300	-	-	-	-	1525	105.14	650	44.81	290	19.99	66	4.55	290	19.99			

Note:

1. This valve is not listed in API 526 standard.

Pressure / Temperature

Selection Chart for Vapors, Gases and Liquids
 1900 and 1900-30 Series, M Orifice - API Area: 3.600 in². (23.226 cm²)

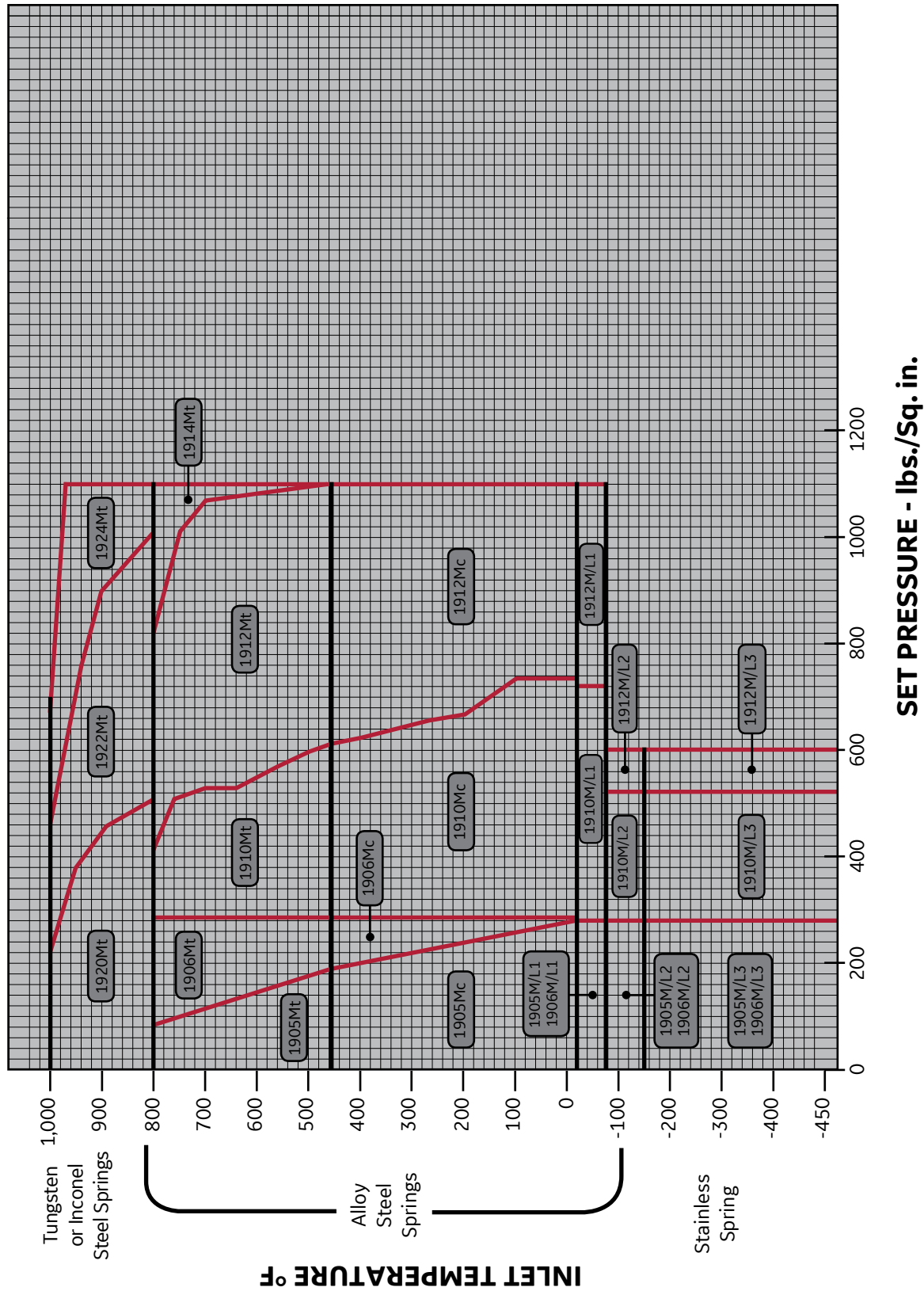

Pressure / Temperature

Pressure Temperature Ratings for N Orifice ¹																				
API Ratings (N Orifice - 4.340 in ² (28.000 cm ²))															Backpressure Ratings @ 100°F (37.8°C)					
Valve Type	Connection				Flanged Ratings		Standard Material of Construction								Conventional		Bellows			
	Inlet		Outlet		Inlet	Outlet	-20 to 100°F (-28.9 to 37.8°C)		450°F (232.2°C)		800°F (426.7°C)		1000°F (537.8°C)				LP		HP	
	in.	mm	in.	mm	R.F. or R.J.	R.F.	psig	barg	psig	barg	psig	barg	psig	barg	psig	barg	psig	barg	psig	barg
1905	4.00	101.6	6.00	152.4	150	150	285	19.65	185	12.75	80	5.51	-	-	285	19.65	73	5.03	80	5.51
1906	4.00	101.6	6.00	152.4	300	150	285	19.65	285	19.65	285	19.65	-	-	285	19.65	73	5.03	80	5.51
1910	4.00	101.6	6.00	152.4	300	150	740	51.02	615	42.40	410	28.26	-	-	285	19.65	73	5.03	160	11.03
1912	4.00	101.6	6.00	152.4	600	150	1000	68.94	1000	68.94	825	56.88	-	-	285	19.65	73	5.03	160	11.03
1914	4.00	101.6	6.00	152.4	900	300	1000	68.94	1000	68.94	1000	68.94	-	-	285	19.65	73	5.03	160	11.03
1920	4.00	101.6	6.00	152.4	300	150	-	-	-	-	510	35.16	215	14.82	285	19.65	73	5.03	160	11.03
1922	4.00	101.6	6.00	152.4	600	150	-	-	-	-	1000	68.94	430	29.64	285	19.65	73	5.03	160	11.03
1924	4.00	101.6	6.00	152.4	900	300	-	-	-	-	1000	68.94	650	44.81	285	19.65	73	5.03	160	11.03

Pressure Temperature Ratings for N Orifice ¹																				
ASME Ratings (N Orifice - 5.047 in ² (32.561 cm ²) Actual)															Backpressure Ratings @ 100°F (37.8°C)					
Valve Type	Connection				Flanged Ratings		Standard Material of Construction								Conventional		Bellows			
	Inlet		Outlet		Inlet	Outlet	-20 to 100°F (-28.9 to 37.8°C)		450°F (232.2°C)		800°F (426.7°C)		1000°F (537.8°C)				LP		HP	
	in.	mm	in.	mm	R.F. or R.J.	R.F.	psig	barg	psig	barg	psig	barg	psig	barg	psig	barg	psig	barg	psig	barg
1905	4.00	101.6	6.00	152.4	150	150	290	19.99	185	12.75	80	5.51	-	-	290	19.99	73	5.03	290	19.99
1906	4.00	101.6	6.00	152.4	300	150	290	19.99	290	19.99	290	19.99	-	-	290	19.99	73	5.03	290	19.99
1910	4.00	101.6	6.00	152.4	300	150	750	51.71	685	47.22	410	28.26	-	-	290	19.99	73	5.03	290	19.99
1912	4.00	101.6	6.00	152.4	600	150	1500	103.42	1368	94.32	825	56.88	-	-	290	19.99	73	5.03	290	19.99
1914	4.00	101.6	6.00	152.4	900	300	1600	110.31	1600	110.31	1235	85.15	-	-	290	19.99	73	5.03	290	19.99
1920	4.00	101.6	6.00	152.4	300	150	-	-	-	-	510	35.16	215	14.82	290	19.99	73	5.03	290	19.99
1922	4.00	101.6	6.00	152.4	600	150	-	-	-	-	1015	69.98	430	29.64	290	19.99	73	5.03	290	19.99
1924	4.00	101.6	6.00	152.4	900	300	-	-	-	-	1525	105.14	650	44.81	290	19.99	73	5.03	290	19.99

Note:

1. This valve is not listed in API 526 standard.

Pressure / Temperature

Selection Chart for Vapors, Gases and Liquids

1900 and 1900-30 Series, N Orifice - API Area: 4.340 in². (28.000 cm²)

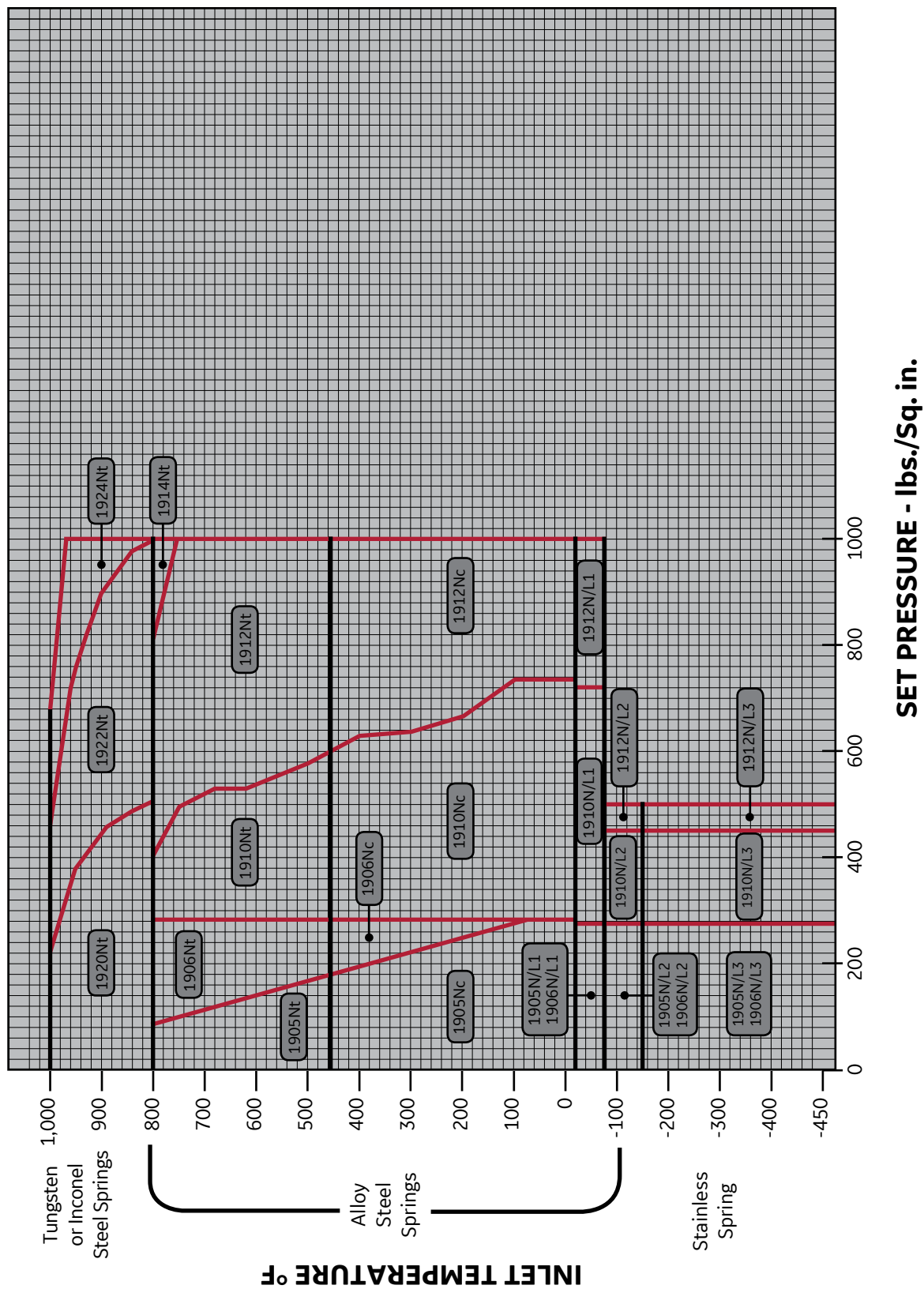

Pressure / Temperature

Pressure Temperature Ratings for P Orifice ¹																				
API Ratings (P Orifice - 6.380 in ² (41.161 cm ²))															Backpressure Ratings @ 100°F (37.8°C)					
Valve Type	Connection				Flanged Ratings		Standard Material of Construction								Conventional		Bellows			
	Inlet		Outlet		Inlet	Outlet	-20 to 100°F (-28.9 to 37.8°C)		450°F (232.2°C)		800°F (426.7°C)		1000°F (537.8°C)				LP		HP	
	in.	mm	in.	mm	R.F. or R.J.	R.F.	psig	barg	psig	barg	psig	barg	psig	barg	psig	barg	psig	barg	psig	barg
1905	4.00	101.6	6.00	152.4	150	150	285	19.65	185	12.75	80	5.51	-	-	285	19.65	56	3.86	80	5.51
1906	4.00	101.6	6.00	152.4	300	150	285	19.65	285	19.65	285	19.65	-	-	285	19.65	56	3.86	80	5.51
1910	4.00	101.6	6.00	152.4	300	150	525	36.19	525	36.19	410	28.26	-	-	285	19.65	56	3.86	150	10.34
1912	4.00	101.6	6.00	152.4	600	150	1000	68.94	1000	68.94	825	56.88	-	-	285	19.65	56	3.86	150	10.34
1914	4.00	101.6	6.00	152.4	900	300	1000	68.94	1000	68.94	1000	68.94	-	-	285	19.65	56	3.86	150	10.34
1920	4.00	101.6	6.00	152.4	300	150	-	-	-	-	510	35.16	215	14.82	285	19.65	56	3.86	160	11.03
1923	4.00	101.6	6.00	152.4	600	150	-	-	-	-	1000	68.94	430	29.64	285	19.65	56	3.86	160	11.03
1924	4.00	101.6	6.00	152.4	900	300	-	-	-	-	1000	68.94	650	44.81	285	19.65	56	3.86	160	11.03

Pressure Temperature Ratings for P Orifice ¹																				
ASME Ratings (P Orifice - 7.417 in ² (47.852 cm ²) Actual)															Backpressure Ratings @ 100°F (37.8°C)					
Valve Type	Connection				Flanged Ratings		Standard Material of Construction								Conventional		Bellows			
	Inlet		Outlet		Inlet	Outlet	-20 to 100°F (-28.9 to 37.8°C)		450°F (232.2°C)		800°F (426.7°C)		1000°F (537.8°C)				LP		HP	
	in.	mm	in.	mm	R.F. or R.J.	R.F.	psig	barg	psig	barg	psig	barg	psig	barg	psig	barg	psig	barg	psig	barg
1905	4.00	101.6	6.00	152.4	150	150	290	19.99	185	12.75	80	5.51	-	-	290	19.99	56	3.86	290	19.99
1906	4.00	101.6	6.00	152.4	300	150	290	19.99	290	19.99	290	19.99	-	-	290	19.99	56	3.86	290	19.99
1910	4.00	101.6	6.00	152.4	300	150	750	51.71	685	47.22	410	28.26	-	-	290	19.99	56	3.86	290	19.99
1912	4.00	101.6	6.00	152.4	600	150	1500	103.42	1368	94.32	825	56.88	-	-	290	19.99	56	3.86	290	19.99
1914	4.00	101.6	6.00	152.4	900	300	1700	117.21	1700	117.21	1235	85.15	-	-	290	19.99	56	3.86	290	19.99
1920	4.00	101.6	6.00	152.4	300	150	-	-	-	-	510	35.16	215	14.82	290	19.99	56	3.86	290	19.99
1923	4.00	101.6	6.00	152.4	600	150	-	-	-	-	1015	69.98	430	29.64	290	19.99	56	3.86	290	19.99
1924	4.00	101.6	6.00	152.4	900	300	-	-	-	-	1525	105.14	650	44.81	290	19.99	56	3.86	290	19.99

Note:

1. This valve is not listed in API 526 standard.

Pressure / Temperature

Selection Chart for Vapors, Gases and Liquids
 1900 and 1900-30 Series, P Orifice - API Area: 6.380 in². (41.161 cm²)

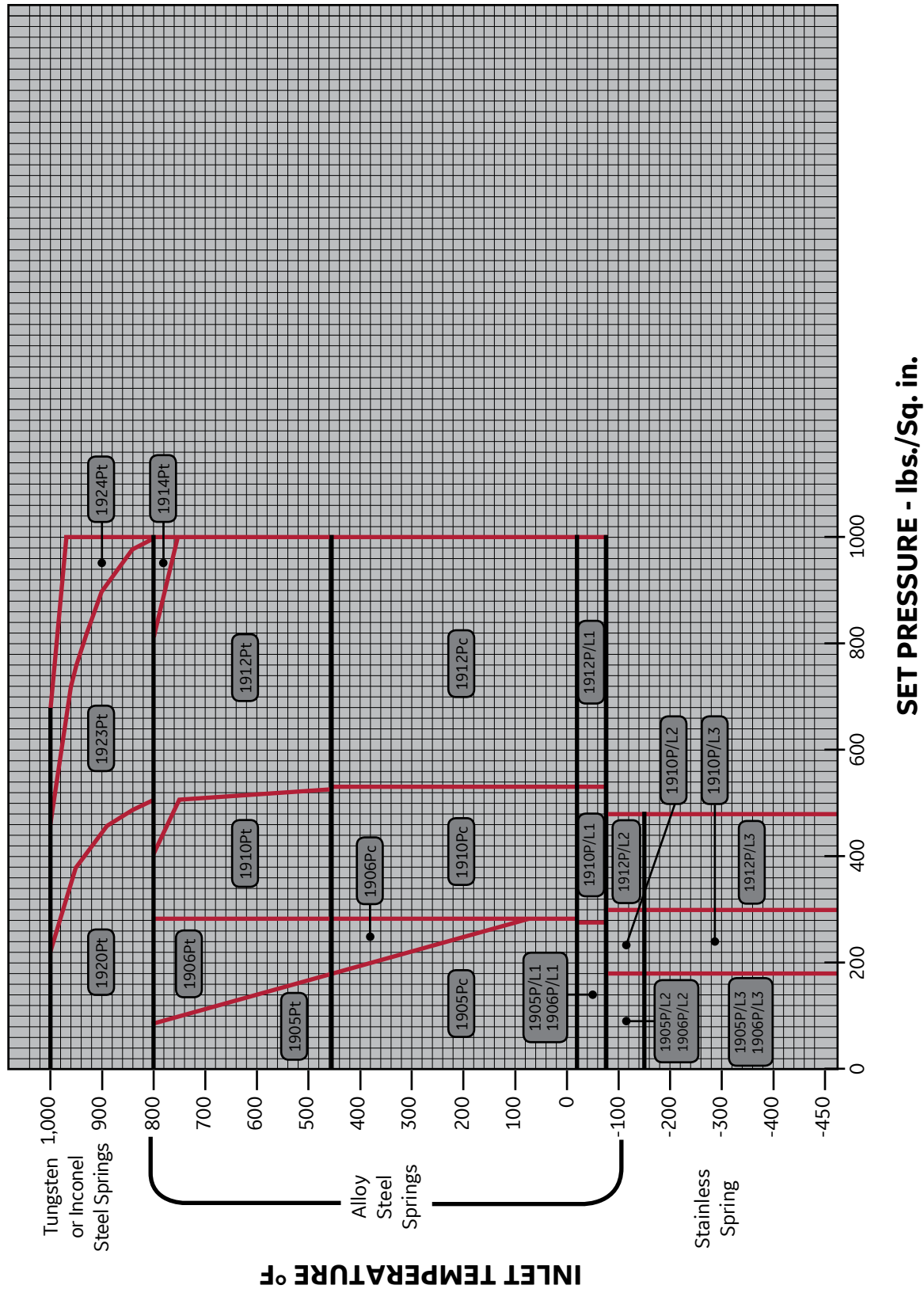

Pressure / Temperature

Pressure Temperature Ratings for Q Orifice ¹																				
API Ratings (Q Orifice - 11.050 in ² (71.290 cm ²))															Backpressure Ratings @ 100°F (37.8°C)					
Valve Type	Connection				Flanged Ratings		Standard Material of Construction								Conventional		Bellows			
	Inlet		Outlet		Inlet	Outlet	-20 to 100°F (-28.9 to 37.8°C)		450°F (232.2°C)		800°F (426.7°C)		1000°F (537.8°C)				LP		HP	
	in.	mm	in.	mm	R.F. or R.J.	R.F.	psig	barg	psig	barg	psig	barg	psig	barg	psig	barg	psig	barg	psig	barg
1905	6.00	152.4	8.00	203.2	150	150	165	11.37	165	11.37	80	5.51	-	-	285	19.65	56	3.86	70	4.83
1906	6.00	152.4	8.00	203.2	300	150	165	11.37	165	11.37	165	11.37	-	-	285	19.65	56	3.86	70	4.83
1910	6.00	152.4	8.00	203.2	300	150	300	20.68	300	20.68	300	20.68	-	-	285	19.65	56	3.86	115	7.93
1912	6.00	152.4	8.00	203.2	600	150	600	41.36	600	41.36	600	41.36	-	-	285	19.65	56	3.86	115	7.93
1920	6.00	152.4	8.00	203.2	300	150	-	-	-	-	165	11.37	165	11.37	285	19.65	56	3.86	115	7.93
1922	6.00	152.4	8.00	203.2	600	150	-	-	-	-	600	41.36	430	29.64	285	19.65	56	3.86	115	7.93

Pressure Temperature Ratings for Q Orifice ¹																				
ASME Ratings (Q Orifice - 12.850 in ² (82.903 cm ²) Actual)															Backpressure Ratings @ 100°F (37.8°C)					
Valve Type	Connection				Flanged Ratings		Standard Material of Construction								Conventional		Bellows			
	Inlet		Outlet		Inlet	Outlet	-20 to 100°F (-28.9 to 37.8°C)		450°F (232.2°C)		800°F (426.7°C)		1000°F (537.8°C)				LP		HP	
	in.	mm	in.	mm	R.F. or R.J.	R.F.	psig	barg	psig	barg	psig	barg	psig	barg	psig	barg	psig	barg	psig	barg
1905	6.00	152.4	8.00	203.2	150	150	290	19.99	185	12.75	80	5.51	-	-	290	19.99	52	3.58	205	14.13
1906	6.00	152.4	8.00	203.2	300	150	290	19.99	290	19.99	290	19.99	-	-	290	19.99	52	3.58	205	14.13
1910	6.00	152.4	8.00	203.2	300	150	650	44.81	650	44.81	410	28.26	-	-	290	19.99	52	3.58	205	14.13
1912	6.00	152.4	8.00	203.2	600	150	900	62.05	900	62.05	825	56.88	-	-	290	19.99	52	3.58	205	14.13
1920	6.00	152.4	8.00	203.2	300	150	-	-	-	-	510	35.16	215	14.82	290	19.99	52	3.58	205	14.13
1922	6.00	152.4	8.00	203.2	600	150	-	-	-	-	900	62.05	430	29.64	290	19.99	52	3.58	205	14.13

Note:

1. This valve is not listed in API 526 standard.

Pressure / Temperature

Selection Chart for Vapors, Gases and Liquids

1900 and 1900-30 Series, Q Orifice - API Area: 11.050 in². (71.290 cm²)

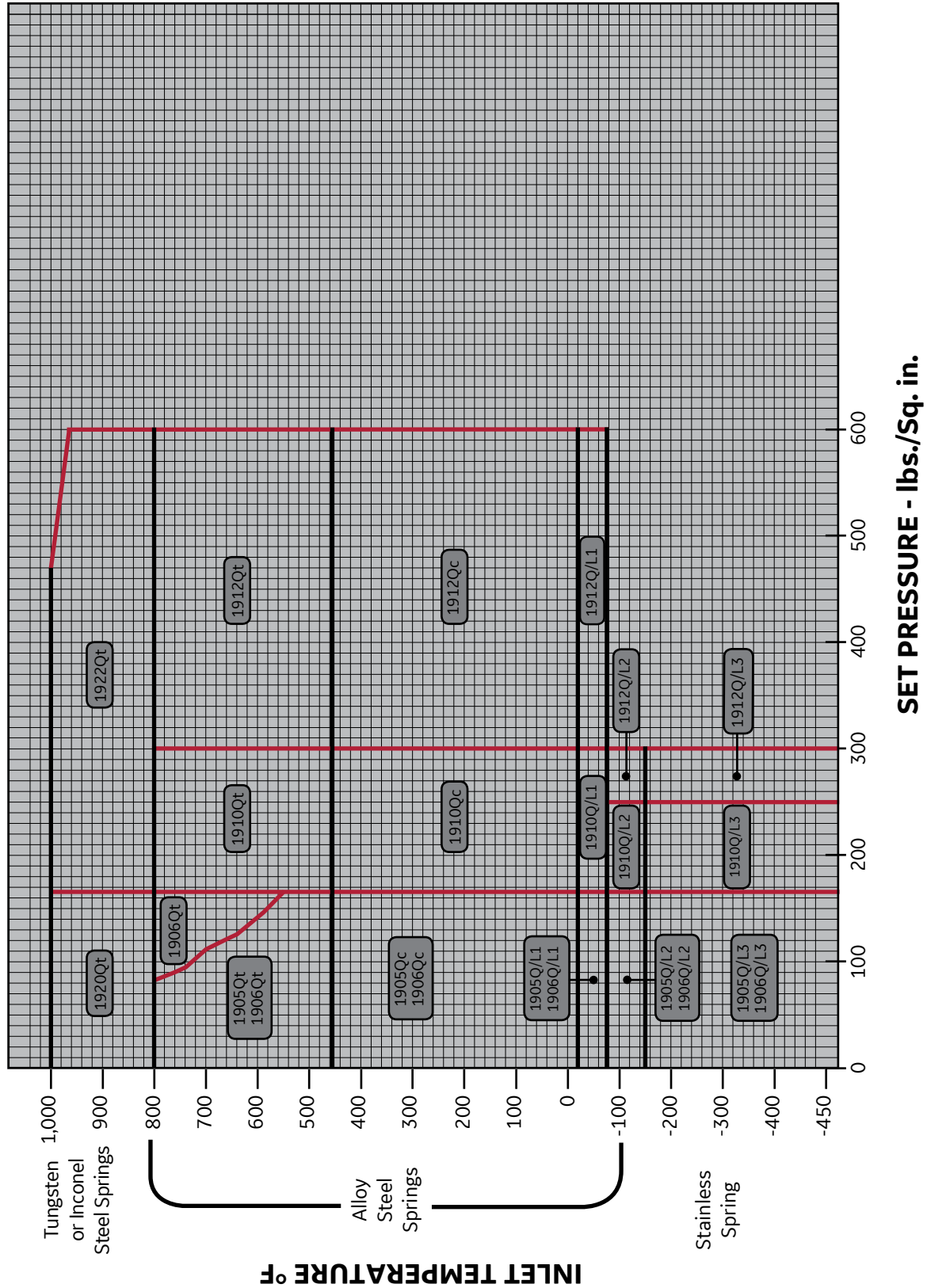

Pressure / Temperature

Pressure Temperature Ratings for R Orifice¹

API Ratings (R Orifice - 16.000 in ² (103.226 cm ²))																	Backpressure Ratings @ 100°F (37.8°C)			
Valve Type	Connection				Flanged Ratings		Standard Material of Construction								Conventional		Bellows			
	Inlet		Outlet		Inlet	Outlet	-20 to 100°F (-28.9 to 37.8°C)		450°F (232.2°C)		800°F (426.7°C)		1000°F (537.8°C)				LP		HP	
	in.	mm	in.	mm	R.F. or R.J.	R.F.	psig	barg	psig	barg	psig	barg	psig	barg	psig	barg	psig	barg	psig	barg
1905	6.00	152.4	8.00	203.2	150	150	100	6.89	100	6.89	80	5.51	-	-	60	4.13	52	3.58	60	4.13
1906	6.00	152.4	8.00	203.2	300	150	100	6.89	100	6.89	100	6.89	-	-	60	4.13	52	3.58	60	4.13
1910	6.00	152.4	10.00	254	300	150	230	15.85	230	15.85	230	15.85	-	-	100	6.89	52	3.58	100	6.89
1912	6.00	152.4	10.00	254	600	150	300	20.68	300	20.68	300	20.68	-	-	100	6.89	52	3.58	100	6.89
1920	6.00	152.4	8.00	203.2	300	150	-	-	-	-	100	6.89	100	6.89	100	6.89	52	3.58	100	6.89
1922	6.00	152.4	10.00	254	600	150	-	-	-	-	300	20.68	300	20.68	100	6.89	52	3.58	100	6.89

Pressure Temperature Ratings for R Orifice¹

ASME Ratings (R Orifice - 18.600 in ² (120.000 cm ²) Actual)																	Backpressure Ratings @ 100°F (37.8°C)				
Valve Type	Connection				Flanged Ratings		Standard Material of Construction								Conventional		Bellows				
	Inlet		Outlet		Inlet	Outlet	-20 to 100°F (-28.9 to 37.8°C)		450°F (232.2°C)		800°F (426.7°C)		1000°F (537.8°C)				LP		HP		
	in.	mm	in.	mm	R.F. or R.J.	R.F.	psig	barg	psig	barg	psig	barg	psig	barg	psig	barg	psig	barg	psig	barg	psig
1905	6.00	152.4	8.00	203.2	150	150	150	10.34	150	10.34	80	5.51	-	-	150	10.34	52	3.58	145	9.99	
1906	6.00	152.4	8.00	203.2	300	150	150	10.34	150	10.34	150	10.34	-	-	150	10.34	52	3.58	145	9.99	
1910	6.00	152.4	10.00	254	300	150	450	31.02	450	31.02	410	28.26	-	-	290	19.99	52	3.58	145	9.99	
1912	6.00	152.4	10.00	254	600	150	650	44.81	650	44.81	650	44.81	-	-	290	19.99	52	3.58	145	9.99	
1920	6.00	152.4	8.00	203.2	300	150	-	-	-	-	450	31.02	215	14.82	290	19.99	52	3.58	145	9.99	
1922	6.00	152.4	10.00	254	600	150	-	-	-	-	650	44.81	430	29.64	290	19.99	52	3.58	145	9.99	

Note:

1. This valve is not listed in API 526 standard.

Pressure / Temperature

Selection Chart for Vapors, Gases and Liquids

1900 and 1900-30 Series, R Orifice - API Area: 16.000 in². (103.226 cm²)

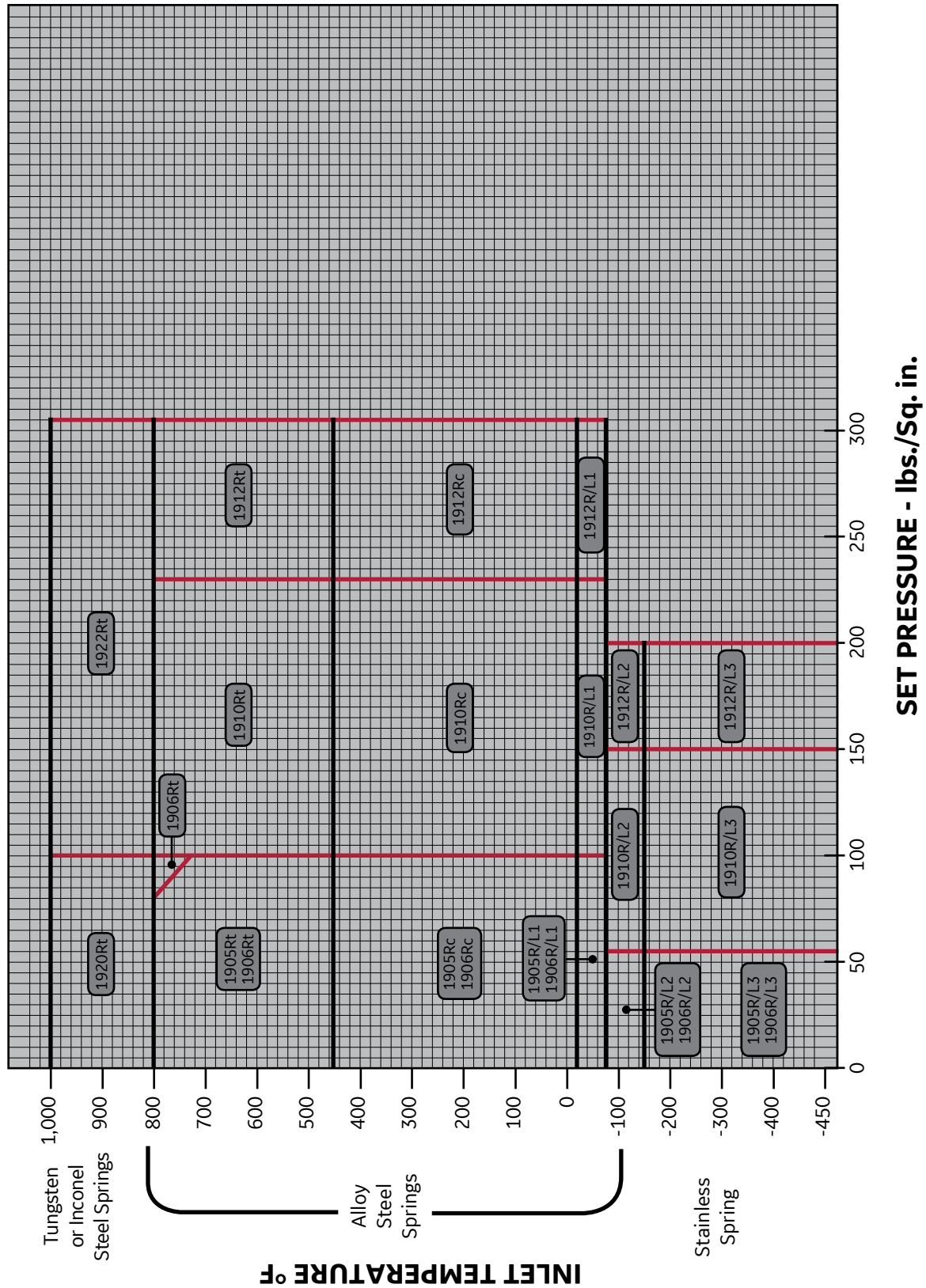

Pressure / Temperature

Pressure Temperature Ratings for T Orifice																				
API Ratings (T Orifice - 26.000 in ² (167.742 cm ²))															Backpressure Ratings @ 100°F (37.8°C)					
Valve Type	Connection				Flanged Ratings		Standard Material of Construction								Conventional		Bellows			
	Inlet		Outlet		Inlet	Outlet	-20 to 100°F (-28.9 to 37.8°C)		450°F (232.2°C)		800°F (426.7°C)		1000°F (537.8°C)				LP		HP	
	in.	mm	in.	mm	R.F. or R.J.	R.F.	psig	barg	psig	barg	psig	barg	psig	barg	psig	barg	psig	barg	psig	barg
1905	8.00	203.2	10.00	254	150	150	65	4.48	65	4.48	65	4.48	-	-	60	4.13	52	3.58	30	2.07
1906	8.00	203.2	10.00	254	300	150	65	4.48	65	4.48	65	4.48	-	-	60	4.13	52	3.58	30	2.07
1910	8.00	203.2	10.00	254	300	150	300	8.27	120	8.27	120	8.27	-	-	100	6.89	52	3.58	100	6.89
1920	8.00	203.2	10.00	254	300	150	-	-	-	-	120	8.27	100	6.89	100	6.89	52	3.58	100	6.89

Pressure Temperature Ratings for Orifice																				
ASME Ratings (Orifice - 30.210 in ² (194.903 cm ²) Actual)															Backpressure Ratings @ 100°F (37.8°C)					
Valve Type	Connection				Flanged Ratings		Standard Material of Construction								Conventional		Bellows			
	Inlet		Outlet		Inlet	Outlet	-20 to 100°F (-28.9 to 37.8°C)		450°F (232.2°C)		800°F (426.7°C)		1000°F (537.8°C)				LP		HP	
	in.	mm	in.	mm	R.F. or R.J.	R.F.	psig	barg	psig	barg	psig	barg	psig	barg	psig	barg	psig	barg	psig	barg
1905	8.00	203.2	10.00	254	150	150	125	8.61	125	8.61	80	5.51	-	-	125	8.61	41	2.82	125	8.61
1906	8.00	203.2	10.00	254	300	150	125	8.61	125	8.61	125	8.61	-	-	125	8.61	41	2.82	125	8.61
1910	8.00	203.2	10.00	254	300	150	360	24.82	360	24.82	360	24.82	-	-	290	19.99	41	2.82	145	9.99
1912 ¹	8.00	203.2	10.00	254	600	150	360	24.82	360	24.82	360	24.82	-	-	290	19.99	41	2.82	145	9.99
1920	8.00	203.2	10.00	254	300	150	-	-	-	-	360	24.82	215	14.82	290	19.99	41	2.82	145	9.99
1922 ¹	8.00	203.2	10.00	254	600	150	-	-	-	-	360	24.82	430	29.64	290	19.99	41	2.82	145	9.99

Note:

1. This valve is not listed in API 526 standard.

Pressure / Temperature

Selection Chart for Vapors, Gases and Liquids

1900 and 1900-30 Series, T Orifice - API Area: 26.000 in². (167.742 cm²)

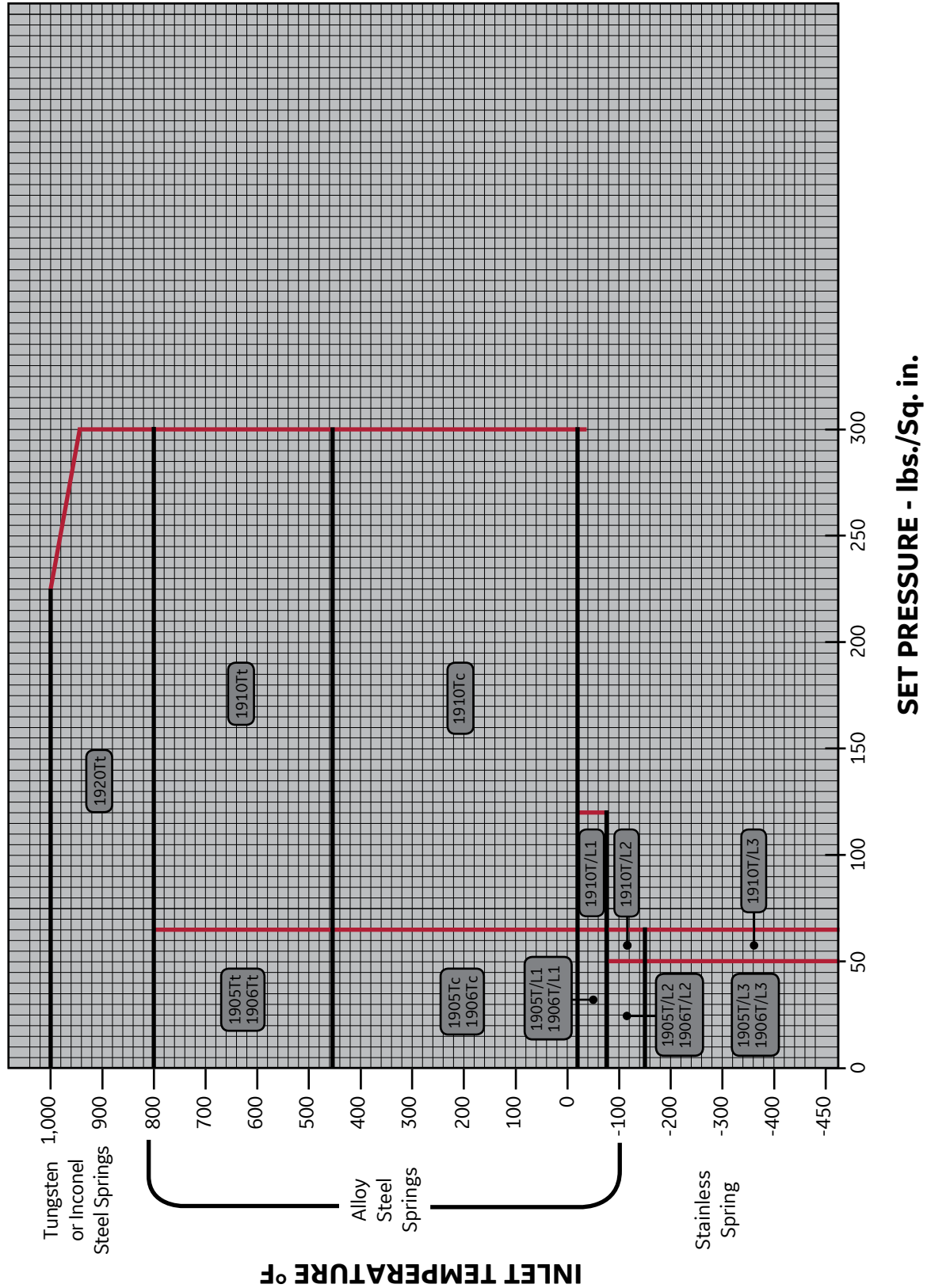

Pressure / Temperature

Pressure Temperature Ratings for U Orifice ¹																					
ASME Ratings (U Orifice - 35.099 in ² (225.445 cm ²) Actual)																Backpressure Ratings @ 100°F (37.8°C)					
Valve Type	Connection				Flanged Ratings		Standard Material of Construction								Conventional		Bellows				
	Inlet		Outlet		Inlet	Outlet	-20 to 100°F (-28.9 to 37.8°C)		450°F (232.2°C)		800°F (426.7°C)		1000°F (537.8°C)				LP		HP		
	in.	mm	in.	mm	R.F. or R.J.	R.F.	psig	barg	psig	barg	psig	barg	psig	barg	psig	barg	psig	barg	psig	barg	
1905	8.00	203.2	10.00	254	150	150	125	8.61	125	8.61	80	5.51	-	-	125	8.61	41	2.82	125	8.61	
1906	8.00	203.2	10.00	254	300	150	125	8.61	125	8.61	125	8.61	-	-	125	8.61	41	2.82	125	8.61	
1910	8.00	203.2	10.00	254	300	150	360	24.82	360	24.82	360	24.82	-	-	290	19.99	41	2.82	145	9.99	
1920	8.00	203.2	10.00	254	300	150	-	-	-	-	360	24.82	215	14.82	290	19.99	41	2.82	145	9.99	

Pressure Temperature Ratings for V Orifice ¹																					
ASME Ratings (V Orifice - 50.260 in ² (324.257 cm ²) Actual)																Backpressure Ratings @ 100°F (37.8°C)					
Valve Type	Connection				Flanged Ratings		Standard Material of Construction								Conventional		Bellows				
	Inlet		Outlet		Inlet	Outlet	-20 to 100°F (-28.9 to 37.8°C)		450°F (232.2°C)		800°F (426.7°C)		1000°F (537.8°C)				LP		HP		
	in.	mm	in.	mm	R.F. or R.J.	R.F.	psig	barg	psig	barg	psig	barg	psig	barg	psig	barg	psig	barg	psig	barg	
1905	10.00	254	14.00	355.6	150	150	154	10.61	154	10.61	80	5.51	-	-	154	10.61	-	-	72	4.96	
1906	10.00	254	14.00	355.6	300	150	154	10.61	154	10.61	154	10.61	-	-	154	10.61	-	-	72	4.96	
1910	10.00	254	14.00	355.6	300	150	300	20.68	300	20.68	300	20.68	-	-	290	19.99	-	-	72	4.96	
1920	10.00	254	14.00	355.6	300	150	-	-	-	-	300	20.68	154	10.61	290	19.99	-	-	72	4.96	

Pressure Temperature Ratings for W Orifice ¹																					
ASME Ratings (W Orifice - 78.996 in ² (509.651 cm ²) Actual)																Backpressure Ratings @ 100°F (37.8°C)					
Valve Type	Connection				Flanged Ratings		Standard Material of Construction								Conventional		Bellows				
	Inlet		Outlet		Inlet	Outlet	-20 to 100°F (-28.9 to 37.8°C)		450°F (232.2°C)		800°F (426.7°C)		1000°F (537.8°C)				LP		HP		
	in.	mm	in.	mm	R.F. or R.J.	R.F.	psig	barg	psig	barg	psig	barg	psig	barg	psig	barg	psig	barg	psig	barg	
1905	12.00	304.8	16.00	406.4	150	150	154	10.61	154	10.61	80	5.51	-	-	154	10.61	-	-	72	4.96	
1906	12.00	304.8	16.00	406.4	300	150	154	10.61	154	10.61	154	10.61	-	-	154	10.61	-	-	72	4.96	
1910	12.00	304.8	16.00	406.4	300	150	300	20.68	300	20.68	300	20.68	-	-	290	19.99	-	-	72	4.96	
1920	12.00	304.8	16.00	406.4	300	150	-	-	-	-	300	20.68	154	10.61	290	19.99	-	-	72	4.96	

Note:

1. This valve is not listed in API 526 standard.

Capacities

Valve Capacity for ASME BandPV Code Section VIII, for Air^{1&2}

Based at 10% overpressure or 3 psig (0.21 barg), whichever is greater, showing 90% actual capacity in accordance with latest ASME Code requirements.
Units of cubic feet of air per minute are at a temperature of 60°F

Orifice Designation	D		E		F		G		H		J		K		L		
	in ²	cm ²	in ²	cm ²	in ²	cm ²	in ²	cm ²	in ²	cm ²	in ²	cm ²	in ²	cm ²	in ²	cm ²	
Orifice Area	0.128	0.825	0.228	1.470	0.357	2.302	0.585	3.774	0.913	5.888	1.496	9.652	2.138	13.794	3.317	21.400	
Set Pressure	Orifice Capacity																
psig	barg	ft ³ /min	m ³ /min	ft ³ /min	m ³ /min	ft ³ /min	m ³ /min	ft ³ /min	m ³ /min	ft ³ /min	m ³ /min	ft ³ /min	m ³ /min	ft ³ /min	m ³ /min	ft ³ /min	m ³ /min
15	1.03	65	1	116	3	183	5	300	8	468	13	767	21	1097	31	1702	48
20	1.37	75	2	134	3	211	5	346	9	539	15	885	25	1264	35	1962	55
30	2.06	95	2	170	4	267	7	437	12	683	19	1119	31	1600	45	2483	70
40	2.75	117	3	209	5	328	9	538	15	840	23	1378	39	1969	55	3055	86
50	3.44	139	3	249	7	390	11	639	18	998	28	1636	46	2338	66	3628	102
60	4.13	161	4	288	8	451	12	740	20	1155	32	1894	53	2707	76	4200	118
70	4.82	184	5	327	9	513	14	841	23	1313	37	2152	60	3076	87	4773	135
80	5.51	206	5	367	10	575	16	942	26	1470	41	2411	68	3445	97	5346	151
90	6.20	228	6	406	11	636	18	1043	29	1628	46	2669	75	3814	108	5918	167
100	6.89	250	7	445	12	698	19	1144	32	1786	50	2927	82	4183	118	6491	183
120	8.27	294	8	524	14	821	23	1346	38	2101	59	3444	97	4922	139	7636	216
140	9.65	338	9	603	17	944	26	1548	43	2416	68	3960	112	5660	160	8781	248
160	11.03	382	10	682	19	1067	30	1750	49	2731	77	4477	126	6398	181	9926	281
180	12.41	426	12	760	21	1190	33	1952	55	3046	86	4993	141	7136	202	11072	313
200	13.78	471	13	839	23	1314	37	2154	60	3361	95	5510	156	7874	222	12217	345
220	15.16	515	14	918	25	1437	40	2356	66	3676	104	6026	170	8612	243	13362	378
240	16.54	559	15	996	28	1560	44	2558	72	3991	113	6543	185	9351	264	14507	410
260	17.92	603	17	1075	30	1683	47	2760	78	4307	121	7059	199	10089	285	15652	443
280	19.30	647	18	1154	32	1806	51	2962	83	4622	130	7576	214	10827	306	16798	475
300	20.68	691	19	1232	34	1930	54	3163	89	4937	139	8092	229	11565	327	17943	508
320	22.06	736	20	1311	37	2053	58	3365	95	5252	148	8609	243	12303	348	19088	540
340	23.44	780	22	1390	39	2176	61	3567	101	5567	157	9125	258	13041	369	20233	572
360	24.82	824	23	1468	41	2299	65	3769	106	5882	166	9642	273	13779	390	21378	605
380	26.20	868	24	1547	43	2422	68	3971	112	6197	175	10158	287	14518	411	22524	637
400	27.57	912	25	1626	46	2546	72	4173	118	6512	184	10675	302	15256	432	23669	670
420	28.95	956	27	1704	48	2669	75	4375	123	6827	193	11191	316	15994	452	24814	702
440	30.33	1000	28	1783	50	2792	79	4577	129	7143	202	11708	331	16732	473	25959	735
460	31.71	1045	29	1862	52	2915	82	4779	135	7458	211	12224	346	17470	494	27104	767
480	33.09	1089	30	1940	54	3038	86	4981	141	7773	220	12741	360	18208	515	28250	799
500	34.47	1133	32	2019	57	3161	89	5183	146	8088	229	13257	375	18946	536	29395	832
600	41.36	1354	38	2413	68	3777	106	6193	175	9663	273	15840	448	22637	641	35121	994
700	48.26	1575	44	2806	79	4393	124	7202	203	11239	318	18422	521	26328	745	40847	1156
800	55.15	1795	50	3199	90	5009	141	8212	232	12815	362	21004	594	30019	850	46573	1318
900	62.05	2016	57	3593	101	5625	159	9222	261	14390	407	23587	667	33709	954	52299	1480
1000	68.94	2237	63	3986	112	6241	176	10231	289	15966	452	26169	741	37400	1059	58025	1643
1100	75.84	2458	69	4380	124	6857	194	11241	318	17541	496	28752	814	41091	1163	63751	1805
1200	82.73	2678	75	4773	135	7473	211	12251	346	19117	541	31334	887	44782	1268	69477	1967
1300	89.63	2899	82	5166	146	8089	229	13260	375	20692	585	33917	960	48472	1372	75203	2129
1400	96.52	3120	88	5560	157	8705	246	14270	404	22268	630	36499	1033	52163	1477	80929	2291
1500	103.42	3341	94	5953	168	9321	263	15280	432	23843	675	39082	1106	55854	1581	86655	2453
2000	137.89	4445	125	7920	224	12400	351	20328	575	31721	898	51994	1472	74308	2104	—	—
2500	172.36	5549	157	9887	279	15480	438	25377	718	39599	1121	64907	1837	—	—	—	—
3000	206.84	6653	188	11855	335	18560	525	30425	861	47477	1344	77819	2203	—	—	—	—
4000	275.79	8861	250	15789	447	24719	699	—	—	—	—	—	—	—	—	—	—
5000	344.73	11068	313	19723	558	30878	874	—	—	—	—	—	—	—	—	—	—
6000	413.68	13276	375	23657	669	—	—	—	—	—	—	—	—	—	—	—	—

Notes:

1. For temperatures other than 60°F (15.6°C) and specific gravities other than air, use formula sizing method.
2. Sizing: Valves may be sized for either ASME or API applications

Capacities

Valve Capacity for ASME BandPV Code Section VIII, for Air ^{1&2}																			
Based at 10% overpressure or 3 psig (0.21 barg), whichever is greater, showing 90% actual capacity in accordance with latest ASME Code requirements. Units of cubic feet of air per minute are at a temperature of 60°F																			
Orifice Designation		M		N		P		Q		R		T		U		V		W	
Orifice Area		in ²	cm ²	in ²	cm ²	in ²	cm ²	in ²	cm ²	in ²	cm ²	in ²	cm ²	in ²	cm ²	in ²	cm ²	in ²	cm ²
Set Pressure		Orifice Capacity																	
psig	barg	ft ³ /min	m ³ /min	ft ³ /min	m ³ /min	ft ³ /min	m ³ /min	ft ³ /min	m ³ /min	ft ³ /min	m ³ /min	ft ³ /min	m ³ /min	ft ³ /min	m ³ /min	ft ³ /min	m ³ /min	ft ³ /min	m ³ /min
15	1.03	2148	60	2589	73	3806	107	6594	186	9544	270	15502	438	17966	508	25791	730	40538	1147
20	1.37	2476	70	2985	84	4388	124	7602	215	11004	311	17873	506	20713	586	29735	842	46736	1323
30	2.06	3133	88	3778	106	5552	157	9619	272	13923	394	22614	640	26207	742	37623	1065	59133	1674
40	2.75	3856	109	4649	131	6832	193	11837	335	17134	485	27829	788	32251	913	46299	1311	72770	2060
50	3.44	4578	129	5520	156	8112	229	14055	397	20345	576	33044	935	38294	1084	54975	1556	86407	2446
60	4.13	5301	150	6391	180	9393	265	16273	460	23555	667	38259	1083	44338	1255	63651	1802	100044	2832
70	4.82	6023	170	7263	205	10673	302	18492	523	26766	757	43474	1231	50381	1426	72327	2048	113680	3219
80	5.51	6746	191	8134	230	11953	338	20710	586	29977	848	48689	1378	56425	1597	81003	2293	127317	3605
90	6.20	7469	211	9005	254	13234	374	22928	649	33188	939	53904	1526	62469	1768	89680	2539	140954	3991
100	6.89	8191	231	9876	279	14514	410	25146	712	36399	1030	59119	1674	68512	1940	98356	2785	154591	4377
120	8.27	9637	272	11619	329	17075	483	29583	837	42820	1212	69549	1969	80600	2282	115708	3276	181864	5149
140	9.65	11082	313	13361	378	19636	556	34019	963	49242	1394	79979	2264	92687	2624	133061	3767	209138	5922
160	11.03	12527	354	15104	427	22196	628	38456	1088	55664	1576	90409	2560	104774	2966	150413	4259	236411	6694
180	12.41	13972	395	16846	477	24757	701	42892	1214	62086	1758	100839	2855	116861	3309	167765	4750	263685	7466
200	13.78	15417	436	18589	526	27318	773	47329	1340	68507	1939	111269	3150	128949	3651	185118	5241	290958	8239
220	15.16	16863	477	20331	575	29879	846	51765	1465	74929	2121	121699	3446	141036	3993	202470	5733	318232	9011
240	16.54	18308	518	22074	625	32439	918	56202	1591	81351	2303	132129	3741	153123	4335	219822	6224	345505	9783
260	17.92	19753	559	23816	674	35000	991	60638	1717	87772	2485	142559	4036	165210	4678	237175	6716	372779	10555
280	19.30	21198	600	25559	723	37561	1063	65075	1842	94194	2667	152990	4332	177298	5020	254527	7207	400052	11328
300	20.68	22644	641	27301	773	40122	1136	69511	1968	100616	2849	163420	4627	189385	5362	271879	7698	427326	12100
320	22.06	24089	682	29044	822	42682	1208	73948	2093	—	—	—	—	—	—	—	—	—	—
340	23.44	25534	723	30786	871	45243	1281	78384	2219	—	—	—	—	—	—	—	—	—	—
360	24.82	26979	763	32529	921	47804	1353	82821	2345	—	—	—	—	—	—	—	—	—	—
380	26.20	28424	804	34271	970	50364	1426	87257	2470	—	—	—	—	—	—	—	—	—	—
400	27.57	29870	845	36014	1019	52925	1498	91694	2596	—	—	—	—	—	—	—	—	—	—
420	28.95	31315	886	37756	1069	55486	1571	96130	2722	—	—	—	—	—	—	—	—	—	—
440	30.33	32760	927	39498	1118	58047	1643	100567	2847	—	—	—	—	—	—	—	—	—	—
460	31.71	34205	968	41241	1167	60607	1716	105003	2973	—	—	—	—	—	—	—	—	—	—
480	33.09	35651	1009	42983	1217	63168	1788	109440	3098	—	—	—	—	—	—	—	—	—	—
500	34.47	37096	1050	44726	1266	65729	1861	113876	3224	—	—	—	—	—	—	—	—	—	—
600	41.36	44322	1255	53438	1513	78533	2223	136058	3852	—	—	—	—	—	—	—	—	—	—
700	48.26	51548	1459	62151	1759	91336	2586	—	—	—	—	—	—	—	—	—	—	—	—
800	55.15	58774	1664	70863	2006	104140	2948	—	—	—	—	—	—	—	—	—	—	—	—
900	62.05	66000	1868	79576	2253	116944	3311	—	—	—	—	—	—	—	—	—	—	—	—
1000	68.94	73226	2073	88288	2500	129747	3674	—	—	—	—	—	—	—	—	—	—	—	—
1100	75.84	80453	2278	—	—	—	—	—	—	—	—	—	—	—	—	—	—	—	—
1200	82.73	—	—	—	—	—	—	—	—	—	—	—	—	—	—	—	—	—	—
1300	89.63	—	—	—	—	—	—	—	—	—	—	—	—	—	—	—	—	—	—
1400	96.52	—	—	—	—	—	—	—	—	—	—	—	—	—	—	—	—	—	—
1500	103.42	—	—	—	—	—	—	—	—	—	—	—	—	—	—	—	—	—	—
2000	137.89	—	—	—	—	—	—	—	—	—	—	—	—	—	—	—	—	—	—
2500	172.36	—	—	—	—	—	—	—	—	—	—	—	—	—	—	—	—	—	—
3000	206.84	—	—	—	—	—	—	—	—	—	—	—	—	—	—	—	—	—	—
4000	275.79	—	—	—	—	—	—	—	—	—	—	—	—	—	—	—	—	—	—
5000	344.73	—	—	—	—	—	—	—	—	—	—	—	—	—	—	—	—	—	—
6000	413.68	—	—	—	—	—	—	—	—	—	—	—	—	—	—	—	—	—	—

Notes:

- For temperatures other than 60°F (15.6°C) and specific gravities other than air, use formula sizing method.
- Sizing: Valves may be sized for either ASME or API applications.

Capacities

Valve Capacity for ASME BandPV Code Section VIII, for Saturated Steam ^{1 & 4}																	
Based on Set Pressure plus 10% overpressure or 3 psig (0.21 barg), whichever is greater showing 90% of actual capacity in accordance with latest ASME Code requirements.																	
Orifice Designation		D		E		F		G		H		J		K		L	
Orifice Area		in ²	cm ²	in ²	cm ²	in ²	cm ²	in ²	cm ²	in ²	cm ²	in ²	cm ²	in ²	cm ²	in ²	cm ²
Set Pressure		Orifice Capacity															
psig	barg	lb/hr	kg/hr	lb/hr	kg/hr	lb/hr	kg/hr	lb/hr	kg/hr	lb/hr	kg/hr	lb/hr	kg/hr	lb/hr	kg/hr	lb/hr	kg/hr
15	1.03	184	83	328	148	513	232	842	381	1314	596	2154	977	3078	1396	4776	2166
20	1.37	212	96	378	171	592	268	970	439	1515	687	2483	1126	3549	1609	5506	2497
30	2.06	268	121	478	216	749	339	1228	557	1916	869	3142	1425	4490	2036	6966	3159
40	2.75	330	149	589	267	922	418	1511	685	2359	1070	3866	1753	5526	2506	8573	3888
50	3.44	392	177	699	317	1095	496	1795	814	2801	1270	4591	2082	6561	2976	10180	4617
60	4.13	454	205	809	366	1267	574	2078	942	3243	1471	5315	2410	7597	3445	11786	5346
70	4.82	516	234	920	417	1440	653	2361	1070	3685	1671	6040	2739	8632	3915	13393	6074
80	5.51	578	262	1030	467	1613	731	2644	1199	4127	1871	6765	3068	9668	4385	14999	6803
90	6.20	640	290	1140	517	1786	810	2928	1328	4569	2072	7489	3396	10703	4854	16606	7532
100	6.89	702	318	1251	567	1959	888	3211	1456	5011	2272	8214	3725	11739	5324	18213	8261
120	8.27	826	374	1472	667	2304	1045	3778	1713	5895	2673	9663	4383	13810	6264	21426	9718
140	9.65	950	430	1692	767	2650	1202	4344	1970	6779	3074	11112	5040	15881	7203	24639	11176
160	11.03	1073	486	1913	867	2996	1358	4911	2227	7663	3475	12561	5697	17952	8142	27852	12633
180	12.41	1197	542	2134	967	3341	1515	5478	2484	8548	3877	14011	6355	20023	9082	31066	14091
200	13.78	1321	599	2355	1068	3687	1672	6044	2741	9432	4278	15460	7012	22095	10022	34279	15548
220	15.16	1445	655	2575	1168	4032	1828	6611	2998	10316	4679	16909	7669	24166	10961	37492	17006
240	16.54	1569	711	2796	1268	4378	1985	7177	3255	11200	5080	18358	8327	26237	11900	40705	18463
260	17.92	1693	767	3017	1368	4724	2142	7744	3512	12084	5481	19807	8984	28308	12840	43918	19920
280	19.30	1817	824	3238	1468	5069	2299	8311	3769	12968	5882	21257	9642	30379	13779	47132	21378
300	20.68	1941	880	3459	1568	5415	2456	8877	4026	13852	6283	22706	10299	32450	14719	50345	22836
320	22.06	2065	936	3679	1668	5761	2613	9444	4283	14737	6684	24155	10956	34521	15658	53558	24293
340	23.44	2189	992	3900	1769	6106	2769	10010	4540	15621	7085	25604	11613	36592	16597	56771	25750
360	24.82	2312	1048	4121	1869	6452	2926	10577	4797	16505	7486	27053	12271	38663	17537	59985	27208
380	26.20	2436	1104	4342	1969	6798	3083	11144	5054	17389	7887	28503	12928	40735	18477	63198	28666
400	27.57	2560	1161	4562	2069	7143	3240	11710	5311	18273	8288	29952	13585	42806	19416	66411	30123
420	28.95	2684	1217	4783	2169	7489	3396	12277	5568	19157	8689	31401	14243	44877	20355	69624	31580
440	30.33	2808	1273	5004	2269	7834	3553	12843	5825	20041	9090	32850	14900	46948	21295	72838	33038
460	31.71	2932	1329	5225	2370	8180	3710	13410	6082	20926	9491	34299	15557	49019	22234	76051	34496
480	33.09	3056	1386	5445	2469	8526	3867	13977	6339	21810	9892	35749	16215	51090	23174	79264	35953
500	34.47	3180	1442	5666	2570	8871	4023	14543	6596	22694	10293	37198	16872	53161	24113	82477	37410
600	41.36	3799	1723	6770	3070	10600	4808	17376	7881	27115	12299	44444	20159	63517	28810	98543	44698
700	48.26	4419	2004	7874	3571	12328	5591	20209	9166	31535	14304	51690	23446	73872	33507	114609	51985
800	55.15	5038	2285	8978	4072	14056	6375	23042	10451	35956	16309	58936	26732	84228	38205	130676	59273
900	62.05	5658	2566	10082	4573	15784	7159	25875	11736	40377	18314	66182	30019	94583	42902	146742	66561
1000	68.94	6277	2847	11186	5073	17512	7943	28708	13021	44798	20320	73428	33306	104939	47599	162808	73848
1100	75.84	6897	3128	12289	5574	19241	8727	31541	14306	49218	22324	80674	36593	115295	52296	178874	81135
1200	82.73	7516	3409	13393	6074	20969	9511	34374	15591	53639	24330	87920	39879	125650	56993	194940	88423
1300	89.63	8136	3690	14497	6575	22697	10295	37207	16876	58060	26335	95166	43166	136006	61691	211006	95710
1400	96.52	8755	3971	15601	7076	24425	11078	40040	18161	62481	28340	102412	46453	146361	66388	227072	102998
142 ²	981.33	8898	4036	15855	7191	24823	11259	40692	18457	63497	28801	104078	47208	148743	67468	230768	104674
1500	103.42	9420	4272	16785	7613	26279	11919	43079	19540	67222	30491	110183	49978	157468	71426	244304	110814
2000	137.89	13024	5907	23207	10526	36334	16480	59562	27016	92943	42158	152343	69101	217721	98756	—	—
2500	172.36	17235	7817	30711	13930	48082	21809	78821	35752	122995	55789	201601	91444	—	—	—	—
2903 ³	200.15	21551	9775	38401	17418	60121	27270	98557	44704	—	—	—	—	—	—	—	—

Notes:

1. Refer to page 1900.95 for correction factor applied for superheated steam.
2. The following Napier factor is applied to the capacity of pressures greater than 1423 psig (98.11 barg): $(0.1906 \times P_{\text{psia}} - 1000) / (0.2292 \times P_{\text{psia}} - 1061)$
3. Maximum permissible set pressure on steam is 2903 psig (200.15 barg). Value is interpolated.
4. Sizing: Valves may be sized for either ASME or API applications

Capacities

Valve Capacity for ASME Band PV Code Section VIII, for Saturated Steam^{1 & 4}

Based on Set Pressure plus 10% overpressure or 3 psig (0.21 barg), whichever is greater, showing 90% of actual capacity in accordance with latest ASME Code requirements.

Orifice Designation		M		N		P		Q		R		T		U		V		W	
Orifice Area		in ²	cm ²	in ²	cm ²	in ²	cm ²	in ²	cm ²	in ²	cm ²	in ²	cm ²	in ²	cm ²	in ²	cm ²	in ²	cm ²
Set Pressure		Orifice Capacity																	
psig	barg	lb/hr	kg/hr	lb/hr	kg/hr	lb/hr	kg/hr	lb/hr	kg/hr	lb/hr	kg/hr	lb/hr	kg/hr	lb/hr	kg/hr	lb/hr	kg/hr	lb/hr	kg/hr
15	1.03	6027	2733	7266	3295	10679	4843	18502	8392	26781	12147	43498	19730	50409	22865	72367	32825	113743	51592
20	1.37	6948	3151	8378	3800	12312	5584	21331	9675	30876	14005	50149	22747	58117	26361	83432	37844	131135	59481
30	2.06	8792	3987	10600	4808	15578	7066	26989	12242	39066	17720	63451	28780	73533	33354	105563	47882	165919	75259
40	2.75	10819	4907	13045	5917	19170	8695	33213	15065	48075	21806	78084	35418	90490	41045	129907	58924	204181	92614
50	3.44	12847	5827	15489	7025	22763	10325	39437	17888	57084	25892	92716	42055	107447	48737	154251	69967	242443	109970
60	4.13	14874	6746	17934	8134	26355	11954	45661	20711	66093	29979	107348	48692	124405	56429	178595	81009	280706	127326
70	4.82	16902	7666	20378	9243	29948	13584	51885	23534	75102	34065	121981	55329	141362	64120	202938	92051	318968	144681
80	5.51	18929	8586	22823	10352	33540	15213	58109	26357	84111	38152	136613	61966	158320	71812	227282	103093	357230	162036
90	6.20	20957	9505	25267	11460	37133	16843	64333	29180	93120	42238	151246	68604	175277	79504	251626	114135	395493	179392
100	6.89	22984	10425	27712	12569	40725	18472	70557	32004	102129	46324	165878	75241	192234	87195	275970	125177	433755	196747
120	8.27	27039	12264	32601	14787	47910	21731	83005	37650	120147	54497	195143	88515	226149	102579	324657	147261	510280	231459
140	9.65	31094	14104	37490	17005	55095	24990	95453	43296	138166	62671	224408	101789	260064	117963	373345	169346	586804	266169
160	11.03	35149	15943	42379	19222	62280	28249	107901	48943	156184	70843	253673	115064	293978	133346	422033	191430	663329	300880
180	12.41	39204	17782	47268	21440	69465	31508	120349	54589	174202	79016	282938	128338	327893	148729	470720	213515	739853	335591
200	13.78	43259	19621	52157	23658	76650	34767	132797	60235	192220	87189	312203	141612	361808	164113	519408	235599	816378	370302
220	15.16	47314	21461	57046	25875	83835	38026	145245	65882	210238	95362	341467	154886	395723	179496	568095	257683	892903	405014
240	16.54	51369	23300	61936	28093	91020	41285	157693	71528	228256	103535	370732	168161	429637	194880	616783	279768	969427	439724
260	17.92	55425	25140	66825	30311	98205	44545	170141	77174	246274	111708	399997	181435	463552	210263	665471	301852	1045952	474435
280	19.30	59480	26979	71714	32528	105390	47804	182589	82820	264292	119880	429262	194709	497467	225647	714158	323936	1122476	509146
300	20.68	63535	28818	76603	34746	112575	51063	195037	88467	282310	128053	458527	207984	531381	241030	762846	346021	1199001	543857
320	22.06	67590	30658	81492	36964	119760	54322	207485	94113	—	—	—	—	—	—	—	—	—	—
340	23.44	71645	32497	86381	39181	126945	57581	219933	99759	—	—	—	—	—	—	—	—	—	—
360	24.82	75700	34336	91270	41399	134130	60840	232381	105406	—	—	—	—	—	—	—	—	—	—
380	26.20	79755	36176	96159	43616	141315	64099	244829	111052	—	—	—	—	—	—	—	—	—	—
400	27.57	83810	38015	101048	45834	148500	67358	257277	116698	—	—	—	—	—	—	—	—	—	—
420	28.95	87865	39854	105938	48052	155685	70617	269725	122345	—	—	—	—	—	—	—	—	—	—
440	30.33	91920	41694	110827	50270	162869	73876	282173	127991	—	—	—	—	—	—	—	—	—	—
460	31.71	95975	43533	115716	52487	170054	77135	294621	133637	—	—	—	—	—	—	—	—	—	—
480	33.09	100030	45372	120605	54705	177239	80394	307069	139284	—	—	—	—	—	—	—	—	—	—
500	34.47	104085	47212	125494	56923	184424	83653	319517	144930	—	—	—	—	—	—	—	—	—	—
600	41.36	124360	56408	149939	68011	220349	99948	381757	173162	—	—	—	—	—	—	—	—	—	—
700	48.26	144635	65605	174385	79099	256274	116243	—	—	—	—	—	—	—	—	—	—	—	—
800	55.15	164911	74802	198830	90187	292199	132539	—	—	—	—	—	—	—	—	—	—	—	—
900	62.05	185186	83998	223276	101276	328124	148834	—	—	—	—	—	—	—	—	—	—	—	—
1000	68.94	205461	93195	247722	112364	364048	165129	—	—	—	—	—	—	—	—	—	—	—	—
1100	75.84	225736	102392	—	—	—	—	—	—	—	—	—	—	—	—	—	—	—	—
1200	82.73	246011	111588	—	—	—	—	—	—	—	—	—	—	—	—	—	—	—	—
1300	89.63	—	—	—	—	—	—	—	—	—	—	—	—	—	—	—	—	—	—
1400	96.52	—	—	—	—	—	—	—	—	—	—	—	—	—	—	—	—	—	—
1423 ²	981.33	—	—	—	—	—	—	—	—	—	—	—	—	—	—	—	—	—	—
1500	103.42	—	—	—	—	—	—	—	—	—	—	—	—	—	—	—	—	—	—
2000	137.89	—	—	—	—	—	—	—	—	—	—	—	—	—	—	—	—	—	—
2500	172.36	—	—	—	—	—	—	—	—	—	—	—	—	—	—	—	—	—	—
2903 ³	200.15	—	—	—	—	—	—	—	—	—	—	—	—	—	—	—	—	—	—

Notes:

1. Refer to page 1900.95 for correction factor applied for superheated steam.
2. The following Napier factor is applied to the capacity of pressures greater than 1423 psig (98.11 barg): $(0.1906 \times P_{psia} - 1000) / (0.2292 \times P_{psia} - 1061)$
3. Maximum permissible set pressure on steam is 2903 psig (200.15 barg). Value is interpolated.
4. Sizing: Valves may be sized for either ASME or API applications

Capacities

Valve Capacity for ASME BandPV Code Section VIII, for Water¹

Based on Set Pressure plus 10% overpressure or 3 psig (0.21 barg), whichever is greater, showing 90% of actual capacity in accordance with latest ASME Code requirements.

Orifice Designation	D		E		F		G		H		J		K		L		
	in ²	cm ²	in ²	cm ²	in ²	cm ²	in ²	cm ²	in ²	cm ²	in ²	cm ²	in ²	cm ²	in ²	cm ²	
	0.128	0.825	0.228	1.470	0.357	2.302	0.585	3.774	0.913	5.888	1.496	9.652	2.138	13.794	3.317	21.400	
Set Pressure	Orifice Capacity																
psig	barg	gpm	L/min	gpm	L/min	gpm	L/min	gpm	L/min	gpm	L/min	gpm	L/min	gpm	L/min	gpm	L/min
15	1.03	13	8	24	15	38	23	63	39	98	61	161	101	230	145	358	225
20	1.37	15	9	27	17	43	27	71	44	111	70	182	114	261	164	404	254
30	2.06	18	11	33	20	52	32	85	53	133	83	218	137	312	196	485	305
40	2.75	21	13	38	23	60	37	98	61	154	97	252	158	361	227	560	353
50	3.44	24	15	43	27	67	42	110	69	172	108	282	177	403	254	626	394
60	4.13	26	16	47	29	73	46	120	75	188	118	309	194	442	278	686	432
70	4.82	28	17	50	31	79	49	130	82	203	128	334	210	477	300	741	467
80	5.51	30	18	54	34	85	53	139	87	217	136	357	225	510	321	792	499
90	6.20	32	20	57	35	90	56	148	93	231	145	378	238	541	341	840	529
100	6.89	34	21	60	37	95	59	156	98	243	153	399	251	570	359	885	558
120	8.27	37	23	66	41	104	65	171	107	266	167	437	275	625	394	970	611
140	9.65	40	25	72	45	112	70	184	116	288	181	472	297	675	425	1047	660
160	11.03	43	27	76	47	120	75	197	124	308	194	505	318	722	455	1120	706
180	12.41	45	28	81	51	127	80	209	131	326	205	535	337	765	482	1188	749
200	13.78	48	30	86	54	134	84	220	138	344	217	564	355	807	509	1252	789
220	15.16	50	31	90	56	141	88	231	145	361	227	592	373	846	533	1313	828
240	16.54	52	32	94	59	147	92	241	152	377	237	618	389	884	557	1372	865
260	17.92	55	34	98	61	153	96	251	158	392	247	644	406	920	580	1428	900
280	19.30	57	35	101	63	159	100	261	164	407	256	668	421	955	602	1482	934
300	20.68	59	37	105	66	165	104	270	170	422	266	691	435	988	623	1534	967
320	22.06	61	38	108	68	170	107	279	176	435	274	714	450	1021	644	1584	999
340	23.44	62	39	112	70	175	110	287	181	449	283	736	464	1052	663	1633	1030
360	24.82	64	40	115	72	180	113	296	186	462	291	757	477	1083	683	1680	1059
380	26.20	66	41	118	74	185	116	304	191	475	299	778	490	1112	701	1726	1088
400	27.57	68	42	121	76	190	119	312	196	487	307	798	503	1141	719	1771	1117
420	28.95	69	43	124	78	195	123	320	201	499	314	818	516	1169	737	1815	1145
440	30.33	71	44	127	80	199	125	327	206	511	322	837	528	1197	755	1857	1171
460	31.71	73	46	130	82	204	128	334	210	522	329	856	540	1224	772	1899	1198
480	33.09	74	46	133	83	208	131	342	215	533	336	875	552	1250	788	1940	1223
500	34.47	76	47	136	85	213	134	349	220	544	343	893	563	1276	805	1980	1249
600	41.36	83	52	149	94	233	146	382	240	596	376	978	617	1398	881	2169	1368
700	48.26	90	56	161	101	252	158	413	260	644	406	1056	666	1510	952	2343	1478
800	55.15	96	60	172	108	269	169	441	278	689	434	1129	712	1614	1018	2505	1580
900	62.05	102	64	182	114	285	179	468	295	731	461	1198	755	1712	1080	2657	1676
1000	68.94	107	67	192	121	301	189	493	311	770	485	1263	796	1805	1138	2800	1766
1100	75.84	113	71	201	126	315	198	517	326	808	509	1324	835	1893	1194	2937	1852
1200	82.73	118	74	210	132	330	208	541	341	844	532	1383	872	1977	1247	3068	1935
1300	89.63	123	77	219	138	343	216	563	355	878	553	1440	908	2058	1298	3193	2014
1400	96.52	127	80	227	143	356	224	584	368	911	574	1494	942	2136	1347	3313	2090
1500	103.42	132	83	235	148	368	232	604	381	943	594	1547	975	2211	1394	3430	2163
2000	137.89	152	95	272	171	426	268	698	440	1089	687	1786	1126	2553	1610	—	—
2500	172.36	170	107	304	191	476	300	780	492	1218	768	1997	1259	—	—	—	—
3000	206.84	187	117	333	210	521	328	855	539	1334	841	2187	1379	—	—	—	—
4000	275.79	215	135	215	135	602	379	987	622	—	—	—	—	—	—	—	—
5000	344.73	241	152	241	152	673	424	—	—	—	—	—	—	—	—	—	—
6000	413.68	264	166	264	166	—	—	—	—	—	—	—	—	—	—	—	—

Note:

1. Sizing: Valves may be sized for either ASME or API applications

Capacities

Valve Capacity for ASME BandPV Code Section VIII, for Water ¹																			
Based on Set Pressure plus 10% overpressure or 3 psig (0.21 barg), whichever is greater, showing 90% of actual capacity in accordance with latest ASME Code requirements.																			
Orifice Designation		M		N		P		Q		R		T		U		V		W	
Orifice Area		in ²	cm ²	in ²	cm ²	in ²	cm ²	in ²	cm ²	in ²	cm ²	in ²	cm ²	in ²	cm ²	in ²	cm ²	in ²	cm ²
Set Pressure		Orifice Capacity																	
psig	barg	gpm	L/Sec	gpm	L/Sec	gpm	L/Sec	gpm	L/Sec	gpm	L/Sec	gpm	L/Sec	gpm	L/Sec	gpm	L/Sec	gpm	L/Sec
15	1.03	452	285	545	343	801	505	1387	875	2009	1267	3263	2058	3780	2385	5428	3424	8532	5382
20	1.37	511	322	616	388	905	570	1568	989	2271	1432	3688	2326	4273	2696	6136	3871	9645	6084
30	2.06	612	386	738	465	1084	683	1879	1185	2720	1716	4418	2787	5118	3229	7350	4636	11553	7288
40	2.75	706	445	852	537	1252	789	2170	1369	3141	1981	5101	3218	5910	3729	8487	5354	13340	8415
50	3.44	790	498	952	600	1400	883	2426	1530	3511	2215	5703	3597	6608	4169	9489	5986	14915	9409
60	4.13	865	545	1043	658	1534	967	2657	1676	3847	2427	6248	3941	7239	4567	10395	6558	16338	10307
70	4.82	935	589	1127	711	1656	1044	2870	1810	4155	2621	6749	4257	7819	4933	11228	7083	17648	11133
80	5.51	999	630	1205	760	1771	1117	3068	1935	4442	2802	7215	4551	8359	5274	12003	7572	18866	11902
90	6.20	1060	668	1278	806	1878	1184	3255	2053	4711	2972	7652	4827	8866	5593	12731	8031	20010	12623
100	6.89	1117	704	1347	849	1980	1249	3431	2164	4966	3132	8066	5088	9345	5896	13420	8466	21093	13307
120	8.27	1224	772	1476	931	2169	1368	3758	2370	5440	3432	8836	5574	10237	6458	14701	9274	23106	14577
140	9.65	1322	834	1594	1005	2343	1478	4059	2560	5876	3707	9544	6021	11057	6976	15879	10017	24958	15745
160	11.03	1413	891	1704	1075	2505	1580	4340	2738	6282	3963	10203	6436	11821	7458	16975	10709	26681	16832
180	12.41	1499	945	1808	1140	2657	1676	4603	2903	6663	4203	10822	6827	12538	7910	18005	11359	28299	17853
200	13.78	1580	996	1905	1201	2800	1766	4852	3061	7023	4430	11407	7196	13216	8338	18979	11973	29830	18819
220	15.16	1657	1045	1998	1260	2937	1852	5089	3210	7366	4647	11964	7547	13861	8745	19905	12557	31286	19737
240	16.54	1731	1092	2087	1316	3068	1935	5315	3353	7694	4854	12496	7883	14478	9134	20790	13116	32677	20615
260	17.92	1802	1136	2173	1370	3193	2014	5532	3490	8008	5052	13007	8205	15069	9507	21639	13651	34012	21457
280	19.30	1870	1179	2255	1422	3313	2090	5741	3621	8310	5242	13498	8515	15638	9866	22456	14167	35296	22267
300	20.68	1935	1220	2334	1472	3430	2163	5942	3748	8602	5426	13971	8814	16187	10212	23244	14664	36534	23048
320	22.06	1999	1261	2410	1520	3542	2234	6137	3871	—	—	—	—	—	—	—	—	—	—
340	23.44	2061	1300	2484	1567	3651	2303	6326	3990	—	—	—	—	—	—	—	—	—	—
360	24.82	2120	1337	2556	1612	3757	2370	6510	4107	—	—	—	—	—	—	—	—	—	—
380	26.20	2178	1374	2627	1657	3860	2435	6688	4219	—	—	—	—	—	—	—	—	—	—
400	27.57	2235	1410	2695	1700	3960	2498	6862	4329	—	—	—	—	—	—	—	—	—	—
420	28.95	2290	1444	2761	1741	4058	2560	7031	4435	—	—	—	—	—	—	—	—	—	—
440	30.33	2344	1478	2826	1782	4154	2620	7197	4540	—	—	—	—	—	—	—	—	—	—
460	31.71	2397	1512	2890	1823	4247	2679	7359	4642	—	—	—	—	—	—	—	—	—	—
480	33.09	2448	1544	2952	1862	4339	2737	7517	4742	—	—	—	—	—	—	—	—	—	—
500	34.47	2499	1576	3013	1900	4428	2793	7672	4840	—	—	—	—	—	—	—	—	—	—
600	41.36	2737	1726	3301	2082	4851	3060	8404	5301	—	—	—	—	—	—	—	—	—	—
700	48.26	2957	1865	3565	2249	5239	3305	9078	5727	—	—	—	—	—	—	—	—	—	—
800	55.15	3161	1994	3811	2404	5601	3533	9704	6122	—	—	—	—	—	—	—	—	—	—
900	62.05	3353	2115	4042	2550	5941	3748	10293	6493	—	—	—	—	—	—	—	—	—	—
1000	68.94	3534	2229	4261	2688	6262	3950	10850	6845	—	—	—	—	—	—	—	—	—	—
1100	75.84	3707	2338	—	—	—	—	—	—	—	—	—	—	—	—	—	—	—	—
1200	82.73	—	—	—	—	—	—	—	—	—	—	—	—	—	—	—	—	—	—
1300	89.63	—	—	—	—	—	—	—	—	—	—	—	—	—	—	—	—	—	—
1400	96.52	—	—	—	—	—	—	—	—	—	—	—	—	—	—	—	—	—	—
1500	103.42	—	—	—	—	—	—	—	—	—	—	—	—	—	—	—	—	—	—
2000	137.89	—	—	—	—	—	—	—	—	—	—	—	—	—	—	—	—	—	—
2500	172.36	—	—	—	—	—	—	—	—	—	—	—	—	—	—	—	—	—	—
3000	206.84	—	—	—	—	—	—	—	—	—	—	—	—	—	—	—	—	—	—
4000	275.79	—	—	—	—	—	—	—	—	—	—	—	—	—	—	—	—	—	—
5000	344.73	—	—	—	—	—	—	—	—	—	—	—	—	—	—	—	—	—	—
6000	413.68	—	—	—	—	—	—	—	—	—	—	—	—	—	—	—	—	—	—

Note:
 1. Sizing: Valves may be sized for either ASME or API applications

Capacities

Superheat Correction Factor ^{1 & 2}																	
Total Temp. (°F)	400	450	500	550	600	650	700	750	800	850	900	950	1000	1050	1100	1150	1200
Flowing Pressure ³ (psia)	Superheat Correction Factor K _{sh}																
50	0.987	0.957	0.93	0.905	0.882	0.861	0.841	0.823	0.805	0.789	0.774	0.759	0.745	0.732	0.719	0.708	0.696
100	0.998	0.963	0.935	0.909	0.885	0.864	0.843	0.825	0.807	0.79	0.775	0.76	0.746	0.733	0.72	0.708	0.697
150	0.984	0.97	0.94	0.913	0.888	0.866	0.846	0.826	0.808	0.792	0.776	0.761	0.747	0.733	0.721	0.709	0.697
200	0.979	0.977	0.945	0.917	0.892	0.869	0.848	0.828	0.81	0.793	0.777	0.762	0.748	0.734	0.721	0.709	0.698
250	-	0.972	0.951	0.921	0.895	0.871	0.85	0.83	0.812	0.794	0.778	0.763	0.749	0.735	0.722	0.71	0.698
300	-	0.968	0.957	0.926	0.898	0.874	0.852	0.832	0.813	0.796	0.78	0.764	0.75	0.736	0.723	0.71	0.699
350	-	0.968	0.963	0.93	0.902	0.877	0.854	0.834	0.815	0.797	0.781	0.765	0.75	0.736	0.723	0.711	0.699
400	-	-	0.963	0.935	0.906	0.88	0.857	0.836	0.816	0.798	0.782	0.766	0.751	0.737	0.724	0.712	0.7
450	-	-	0.961	0.94	0.909	0.883	0.859	0.838	0.818	0.8	0.783	0.767	0.752	0.738	0.725	0.712	0.7
500	-	-	0.961	0.946	0.914	0.886	0.862	0.84	0.82	0.801	0.784	0.768	0.753	0.739	0.725	0.713	0.701
550	-	-	0.962	0.952	0.918	0.889	0.864	0.842	0.822	0.803	0.785	0.769	0.754	0.74	0.726	0.713	0.701
600	-	-	0.964	0.958	0.922	0.892	0.867	0.844	0.823	0.804	0.787	0.77	0.755	0.74	0.727	0.714	0.702
650	-	-	0.968	0.958	0.927	0.896	0.869	0.846	0.825	0.806	0.788	0.771	0.756	0.741	0.728	0.715	0.702
700	-	-	-	0.958	0.931	0.899	0.872	0.848	0.827	0.807	0.789	0.772	0.757	0.742	0.728	0.715	0.703
750	-	-	-	0.958	0.936	0.903	0.875	0.85	0.828	0.809	0.79	0.774	0.758	0.743	0.729	0.716	0.703
800	-	-	-	0.96	0.942	0.906	0.878	0.852	0.83	0.81	0.792	0.774	0.759	0.744	0.73	0.716	0.704
850	-	-	-	0.962	0.947	0.91	0.88	0.855	0.832	0.812	0.793	0.776	0.76	0.744	0.73	0.717	0.704
900	-	-	-	0.965	0.953	0.914	0.883	0.857	0.834	0.813	0.794	0.777	0.76	0.745	0.731	0.718	0.705
950	-	-	-	0.969	0.958	0.918	0.886	0.86	0.836	0.815	0.796	0.778	0.761	0.746	0.732	0.718	0.705
1000	-	-	-	0.974	0.959	0.923	0.89	0.862	0.838	0.816	0.797	0.779	0.762	0.747	0.732	0.719	0.706
1050	-	-	-	-	0.96	0.927	0.893	0.864	0.84	0.818	0.798	0.78	0.763	0.748	0.733	0.719	0.707
1100	-	-	-	-	0.962	0.931	0.896	0.867	0.842	0.82	0.8	0.781	0.764	0.749	0.734	0.72	0.707
1150	-	-	-	-	0.964	0.936	0.899	0.87	0.844	0.821	0.801	0.782	0.765	0.749	0.735	0.721	0.708
1200	-	-	-	-	0.966	0.941	0.903	0.872	0.846	0.823	0.802	0.784	0.766	0.75	0.735	0.721	0.708
1250	-	-	-	-	0.969	0.946	0.906	0.875	0.848	0.825	0.804	0.785	0.767	0.751	0.736	0.722	0.709
1300	-	-	-	-	0.973	0.952	0.91	0.878	0.85	0.826	0.805	0.786	0.768	0.752	0.737	0.723	0.709
1350	-	-	-	-	0.977	0.958	0.914	0.88	0.852	0.828	0.807	0.787	0.769	0.753	0.737	0.723	0.71
1400	-	-	-	-	0.982	0.963	0.918	0.883	0.854	0.83	0.808	0.788	0.77	0.754	0.738	0.724	0.71
1450	-	-	-	-	0.987	0.968	0.922	0.886	0.857	0.832	0.809	0.79	0.771	0.754	0.739	0.724	0.711
1500	-	-	-	-	0.993	0.97	0.926	0.889	0.859	0.833	0.811	0.791	0.772	0.755	0.74	0.725	0.711
1550	-	-	-	-	-	0.972	0.93	0.892	0.861	0.835	0.812	0.792	0.773	0.756	0.74	0.726	0.712
1600	-	-	-	-	-	0.973	0.934	0.894	0.863	0.836	0.813	0.792	0.774	0.756	0.74	0.726	0.712
1650	-	-	-	-	-	0.973	0.936	0.895	0.863	0.836	0.812	0.791	0.772	0.755	0.739	0.724	0.71
1700	-	-	-	-	-	0.973	0.938	0.895	0.863	0.835	0.811	0.79	0.771	0.754	0.738	0.723	0.709
1750	-	-	-	-	-	0.974	0.94	0.896	0.862	0.835	0.81	0.789	0.77	0.752	0.736	0.721	0.707
1800	-	-	-	-	-	0.975	0.942	0.897	0.862	0.834	0.81	0.788	0.768	0.751	0.735	0.72	0.705
1850	-	-	-	-	-	0.976	0.944	0.897	0.862	0.833	0.809	0.787	0.767	0.749	0.733	0.718	0.704
1900	-	-	-	-	-	0.977	0.946	0.898	0.862	0.832	0.807	0.785	0.766	0.748	0.731	0.716	0.702
1950	-	-	-	-	-	0.979	0.949	0.898	0.861	0.832	0.806	0.784	0.764	0.746	0.729	0.714	0.7
2000	-	-	-	-	-	0.982	0.952	0.899	0.861	0.831	0.805	0.782	0.762	0.744	0.728	0.712	0.698
2050	-	-	-	-	-	0.985	0.954	0.899	0.86	0.83	0.804	0.781	0.761	0.742	0.726	0.71	0.696
2100	-	-	-	-	-	0.988	0.956	0.9	0.86	0.828	0.802	0.779	0.759	0.74	0.724	0.708	0.694
2150	-	-	-	-	-	-	0.956	0.9	0.859	0.827	0.801	0.778	0.757	0.738	0.722	0.706	0.692
2200	-	-	-	-	-	-	0.955	0.901	0.859	0.826	0.799	0.776	0.755	0.736	0.72	0.704	0.69
2250	-	-	-	-	-	-	0.954	0.901	0.858	0.825	0.797	0.774	0.753	0.734	0.717	0.702	0.687
2300	-	-	-	-	-	-	0.953	0.901	0.857	0.823	0.795	0.772	0.751	0.732	0.715	0.699	0.685
2350	-	-	-	-	-	-	0.952	0.902	0.856	0.822	0.794	0.769	0.748	0.729	0.712	0.697	0.682
2400	-	-	-	-	-	-	0.952	0.902	0.855	0.82	0.791	0.767	0.746	0.727	0.71	0.694	0.679
2450	-	-	-	-	-	-	0.951	0.902	0.854	0.818	0.789	0.765	0.743	0.724	0.707	0.691	0.677
2500	-	-	-	-	-	-	0.951	0.902	0.852	0.816	0.787	0.762	0.74	0.721	0.704	0.688	0.674
2550	-	-	-	-	-	-	0.951	0.902	0.851	0.814	0.784	0.759	0.738	0.718	0.701	0.685	0.671
2600	-	-	-	-	-	-	0.951	0.903	0.849	0.812	0.782	0.756	0.735	0.715	0.698	0.682	0.664
2650	-	-	-	-	-	-	0.952	0.903	0.848	0.809	0.779	0.754	0.731	0.712	0.695	0.679	0.664
2700	-	-	-	-	-	-	0.952	0.903	0.846	0.807	0.776	0.75	0.728	0.708	0.691	0.675	0.661
2750	-	-	-	-	-	-	0.953	0.903	0.844	0.804	0.773	0.747	0.724	0.705	0.687	0.671	0.657
2800	-	-	-	-	-	-	0.956	0.903	0.842	0.801	0.769	0.743	0.721	0.701	0.684	0.668	0.653
2850	-	-	-	-	-	-	0.959	0.902	0.839	0.798	0.766	0.739	0.717	0.697	0.679	0.663	0.649
2900	-	-	-	-	-	-	0.963	0.902	0.836	0.794	0.762	0.735	0.713	0.693	0.675	0.659	0.645
2950	-	-	-	-	-	-	-	0.902	0.834	0.79	0.758	0.731	0.708	0.688	0.671	0.655	0.64

Notes:

1. For capacity on superheated steam, multiply saturated steam capacity by correction factor.
2. Convert set pressure from (psig) to (psia) flowing pressure.
3. psia flowing = [set pressure psig x overpressure] + 14.7

Valve Configuration Code

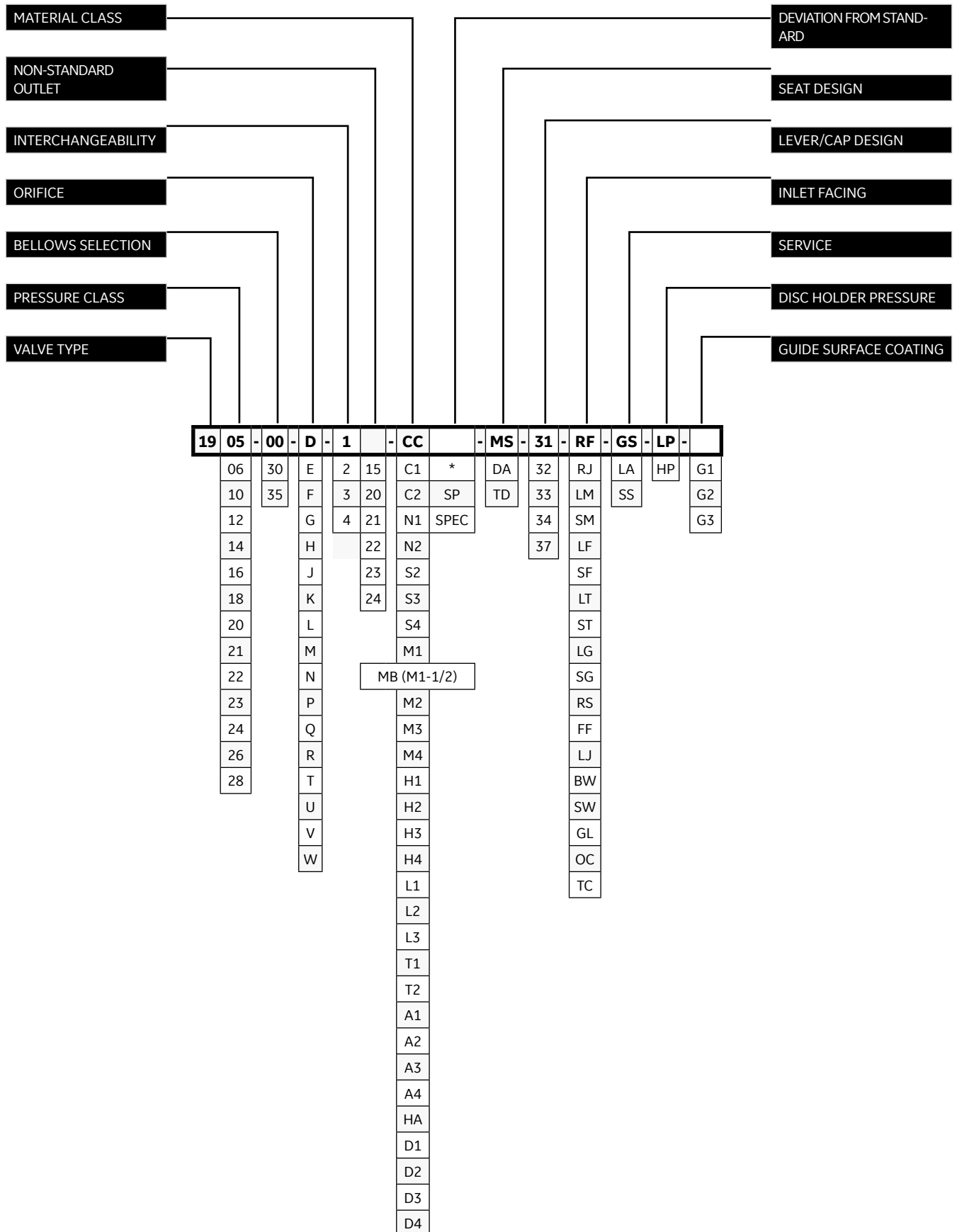

Valve Configuration Code

Pressure Class	
Designation	Class
05	150
06	300
10	300
12	600
14	900
16	1500
18	2500
20	300
21 (-2T Only)	300
22	600
23 (P-2 Only)	600
24	900
26	1500
28	2500

Seat Design	
Designation	Type
MS	Metal Seat
DA	O-ring
TD	Thermodisc

Bellows Selection	
Designation	Range
00	Non Bellows
30	Bellows
35	Balanced Bellows

Standard Valve Connection				
Orifice	Area (API)		Area (ASME)	
	in ²	cm ²	in ²	cm ²
D	0.110	0.710	0.128	0.825
E	0.196	1.265	0.228	1.470
F	0.307	1.981	0.357	2.302
G	0.503	3.245	0.585	3.774
H	0.785	5.065	0.913	5.888
J	1.287	8.303	1.496	9.652
K	1.838	11.858	2.138	13.794
L	2.853	18.406	3.317	21.400
M	3.600	23.226	4.186	27.006
N	4.340	28.000	5.047	32.561
P	6.380	41.161	7.417	47.852
Q	11.050	71.290	12.850	82.903
R	16.000	103.226	18.600	120.000
T	26.000	167.742	30.210	194.903
U	N/A	N/A	35.000	225.806
V	N/A	N/A	50.260	324.257
W	N/A	N/A	78.996	509.651

Non-Standard Outlet						
Valve Type	Orifice	Standard Outlet Flange Rating	Actual Body Class Rating	Actual Outlet Flange Class	Mated "M" - Rated "R"	Non Standard Outlet Code ¹
1905-1912	All	150	150	>150	M	15
1912-1918	D-G	300	300	>300		
1916	H-L					
1900	All	>150	150	300	R	20
			600	600		21
			900	900		22
			1500	1500		23
			2500	2500		24

¹The configuration code is modified by adding the "Non-Standard Outlet Code" from this column to the interchangeability number. For example: the interchangeability number is -1 and the Configuration Code from this table is 15 then the interchangeability number is -115.

Interchangeability Number	
Designation	Valve Type
1 to 4	Numerical values vary by Orifice

Material Trim	
Designation	Trim
CC	Standard Material
C1	Ambient Temp. to -50°F [LCC Construction]
C2	Ambient Temp. To -50°F [St. St. Construction]
N1	Carbon Steel Sour Gas
N2	Stainless Steel Sour Gas
S2	Stainless St. [Internals, Except Spring Assy.]
S3	Stainless St. [All except Spring Assy.]
S4	Stainless St. [Complete Valve]
M1	Monel [Nozzle and Disc]
MB (M1-1/2)	Monel [M1+Disc Holder, Adj. Ring and Ring Pin]
M2	Monel [Internals, except Spring Assy.]
M3	Monel [All except Spring Assy.]
M4	Monel [Complete Valve]
H1	Hastelloy C [Nozzle and Disc]
H2	Hastelloy C [Internals, except Spring Assy.]
H3	Hastelloy C [All except Spring Assy.]
H4	Hastelloy C [Complete Valve]
L1	Low Temperature Service [-21°F To -75°F]
L2	Low Temperature Service [-76°F To -150°F]
L3	Low Temperature Service [-151°F To -450°F]
T1	High Temperature Service [1001°F To 1200°F]
T2	High Temperature Service [1201°F To 1500°F]
A1	Alloy 20 [Nozzle and Disc]
A2	Alloy 20 [Internals, except Spring Assy.]
A3	Alloy 20 [All except Spring Assy.]
A4	Alloy 20 [Complete Valve]
HA	Hydrofluoric Acid [Anhydrous Hf Alky]
D1	Duplex [Nozzle and Disc]
D2	Duplex [Internals, except Spring Assy.]
D3	Duplex [All except Spring Assy., Stud/Nut and Bellows Assy.]
D4	Duplex [All except Stud/Nut and Bellows Assy.]

Valve Configuration Code

Lever/Cap Design	
Designation	Type
31	Screwed
32	Bolted
33	Packed
34	Plain
37	Air Operated

Service	
Designation	Type
GS	Gas
LA	Liquid
SS	Steam

Inlet Flange Facing	
Designation	Facing
RF	Raised Face Serrated
RJ	Ring Joint
LM	Large Male
SM	Small Male
LF	Large Female
SF	Small Female
LT	Large Tongue
ST	Small Tongue
LG	Large Groove
SG	Small Groove
RS	Raised Face, Smooth
LJ	Lens Joint
BW	Butt Weld
SW	Socket Weld
GL	Grayloc
OC	Oteco
TC	Tri-Clamp

Disc Holder Pressure Design	
Designation	Pressure Range ¹
LP	Low Pressure
HP	High Pressure

Guide Surface Coating	
Designation	Part Coated
G1	Glide-Aloy™ Disc Holder
G2	Glide-Aloy™ Guide
G3	Glide-Aloy™ Disc Holder and Guide

Note:

1. Pressure Ranges vary per orifice.

Ordering a 1900 Safety Relief Valve

Specification Sheet			
		Page _____ of _____	
Requisition No.	-----		
Job No.	-----		
Date	-----		
Revised By	-----		
General			
1.	Item Number:		
2.	Tag Number:		
3.	Service, Line or Equipment No:		
4.	Number Required:		
Basis of Selection			
5.	Code:		
	<input type="checkbox"/> ASME Sec. I (1900/P Series only)		
	<input type="checkbox"/> ASME Sec. III		
	<input type="checkbox"/> ASME Sec. VIII		
	<input type="checkbox"/> OTHER Specify:		
6.	Comply with API 526: <input type="checkbox"/> YES <input type="checkbox"/> NO		
7.	<input type="checkbox"/> Fire <input type="checkbox"/> OTHER Specify:		
8.	Rupture Disk: <input type="checkbox"/> YES <input type="checkbox"/> NO		
Valve Design			
9.	Type: Safety Relief		
10.	Design: <input type="checkbox"/> Conventional <input type="checkbox"/> Bellows		
	<input type="checkbox"/> Closed Bonnet <input type="checkbox"/> Yoke/Open Bonnet		
	<input type="checkbox"/> Metal Seat <input type="checkbox"/> Resilient Seat		
	<input type="checkbox"/> API 527 Seat Tightness		
	<input type="checkbox"/> OTHER Specify:		
Connections			
11.	Inlet Size:	Rating:	Facing:
	Outlet Size:	Rating:	Facing:
12.	<input type="checkbox"/> OTHER Specify:		
Materials			
13.	Body/Bonnet:		
14.	Guide/Rings:		
15.	Seat Material:		
	Metal:		
	Resilient:		
16.	Bellows:		
17.	Spring:		
18.	Comply with NACE MRO 175 <input type="checkbox"/> YES <input type="checkbox"/> NO		
19.	<input type="checkbox"/> OTHER Specify:		
20.	Cap and Lever Selection		
	<input type="checkbox"/> Screwed Cap (Standard) <input type="checkbox"/> Bolted Cap		
	<input type="checkbox"/> Plain Lever <input type="checkbox"/> Packed Lever <input type="checkbox"/> Gag		
21.	<input type="checkbox"/> OTHER Specify:		
Service Conditions			
22.	Fluid and State:		
23.	Required Capacity per Valve and Units:		
24.	Molecular Weight or Specific Gravity:		
25.	Viscosity at Flowing Temperature and Units:		
26.	Operating Pressure and Units:		
27.	Blowdown: <input type="checkbox"/> Standard <input type="checkbox"/> Other		
28.	Latent Heat of Vaporization and Units:		
29.	Operating Temperature and Units:		
30.	Relieving Temperature and Units:		
31.	Built-up Back Pressure and Units:		
32.	Superimposed Back Pressure and Units:		
33.	Cold differential Test Pressure and Units:		
34.	Allowable Overpressure in Percent or Units:		
35.	Compressibility Factor, Z:		
36.	Ratio of Specific Heats:		
Sizing and Selection			
37.	Calculated Orifice Area (square inches):		
38.	Selected Orifice Area (square inches):		
39.	Orifice Designation (letter):		
40.	Manufacturer:		
41.	Model Number:		
42.	Vendor Calculations Required: <input type="checkbox"/> YES <input type="checkbox"/> NO		

DIRECT SALES OFFICE LOCATIONS

AUSTRALIA

Brisbane
Phone: +61-7-3001-4319
Fax: +61-7-3001-4399

Perth
Phone: +61-8-6595-7018
Fax: +61-8-6595-7299

Melbourne
Phone: +61-3-8807-6002
Fax: +61-3-8807-6577

BELGIUM
Phone: +32-2-344-0970
Fax: +32-2-344-1123

BRAZIL
Phone: +55-19-2104-6900

CHINA
Phone: +86-10-5738-8888
Fax: +86-10-5918-9707

FRANCE
Courbevoie
Phone: +33-1-4904-9000
Fax: +33-1-4904-9010

GERMANY
Ratingen
Phone: +49-2102-108-0
Fax: +49-2102-108-111

INDIA
Mumbai
Phone: +91-22-8354790
Fax: +91-22-8354791

New Delhi
Phone: +91-11-2-6164175
Fax: +91-11-5-1659635

ITALY

Phone: +39-081-7892-111
Fax: +39-081-7892-208

JAPAN

Tokyo
Phone: +81-03-6871-9008
Fax: +81-03-6890-4620

KOREA

Phone: +82-2-2274-0748
Fax: +82-2-2274-0794

MALAYSIA

Phone: +60-3-2161-0322
Fax: +60-3-2163-6312

MEXICO

Phone: +52-55-3640-5060

THE NETHERLANDS

Phone: +31-15-3808666

RUSSIA

Veliky Novgorod
Phone: +7-8162-55-7898
Fax: +7-8162-55-7921

Moscow

Phone: +7 495-585-1276
Fax: +7 495-585-1279

SAUDI ARABIA

Phone: +966-3-341-0278
Fax: +966-3-341-7624

SINGAPORE

Phone: +65-6861-6100
Fax: +65-6861-7172

SOUTH AFRICA

Phone: +27-11-452-1550
Fax: +27-11-452-6542

SOUTH & CENTRAL

AMERICA AND THE CARIBBEAN
Phone: +55-12-2134-1201
Fax: +55-12-2134-1238

SPAIN

Phone: +34-93-652-6430
Fax: +34-93-652-6444

UNITED ARAB EMIRATES

Phone: +971-4-8991-777
Fax: +971-4-8991-778

UNITED KINGDOM

Bracknell
Phone: +44-1344-460-500
Fax: +44-1344-460-537

Skelmersdale

Phone: +44-1695-526-00
Fax: +44-1695-526-01

UNITED STATES

Jacksonville, Florida
Phone: +1-904-570-3409

Deer Park, Texas

Phone: +1-281-884-1000
Fax: +1-281-884-1010

Houston, Texas

Phone: +1-281-671-1640
Fax: +1-281-671-1735

bhge.com

*Denotes a trademark of Baker Hughes, a GE company, LLC.

Other company names and product names used in this document are the registered trademarks or trademarks of their respective owners.

© 2018 Baker Hughes, a GE company, LLC - All rights reserved.

BHGE reserves the right to make changes in specifications and features shown herein, or discontinue the product described at any time without notice or obligation. Contact your BHGE representative for the most current information. The BHGE logo is a trademark of Baker Hughes, a GE company, LLC. Baker Hughes, a GE company, the GE monogram are trademarks of the General Electric Company and Baker Hughes, a GE company, LLC.

