

Consolidated* **19000 Series**

Safety Relief Valve

ASME and PED certified, the 19000 Safety Relief Valve provides superior capacity and blowdown performance on all media types



Conversion Table

All the USCS values are converted to metric values using the following conversion factors:

USCS Unit	Conversion Factor	Metric Unit
in.	25.4	mm
lb.	0.4535924	kg
in ²	6.4516	cm ²
ft ³ /min	0.02831685	m ³ /min
gal/min	3.785412	L/min
lb/hr	0.4535924	kg/hr
psig	0.06894757	barg
ft lb	1.3558181	Nm
°F	5/9 (°F-32)	°C

Scope of Design

Standard Inlet/Outlet Connections and Pressure Classes												
Orifice		Pressure Range				Valve Type	Inlet			Outlet		
in ²	cm ²	psig		barg			Size		Type	Size		Type
		min	max	min	max		in	mm		in	mm	
0.096	0.619	5	290	0.34	19.99	19096L	.50	12.70	MNPT	1.00	25.4	FNPT
							.75	19.05	MNPT	1.00	25.4	FNPT
							.75	19.05	FNPT	1.00	25.4	FNPT
							1.00	25.40	MNPT	1.00	25.4	FNPT
		291	2000	20.06	137.90	19096M	.50	12.70	MNPT	1.00	25.4	FNPT
							.75	19.05	MNPT	1.00	25.4	FNPT
							.75	19.05	FNPT	1.00	25.4	FNPT
		2001	5000	137.96	344.74	19096H	.75	19.05	FNPT	1.00	25.4	FNPT
		0.096 BP	0.619	50	2000	3.45	137.90	19096M-BP	.50	12.70	MNPT	1.00
.75	19.05								MNPT	1.00	25.4	FNPT
.75	19.05								FNPT	1.00	25.4	FNPT
1.00	25.40								MNPT	1.00	25.4	FNPT
0.110	0.710	5	290	0.34	19.99	19110L	.50	12.70	MNPT	1.00	25.4	FNPT
							.75	19.05	MNPT	1.00	25.4	FNPT
							.75	19.05	FNPT	1.00	25.4	FNPT
							1.00	25.40	MNPT	1.00	25.4	FNPT
		291	2000	20.06	137.90	19110M	.50	12.70	MNPT	1.00	25.4	FNPT
							.75	19.05	MNPT	1.00	25.4	FNPT
							.75	19.05	FNPT	1.00	25.4	FNPT
		2001	5000	137.96	344.74	19110H	.75	19.05	FNPT	1.00	25.4	FNPT
		0.126	0.813	5	290	0.34	19.99	19126L	.75	19.05	MNPT	1.00
.75	19.05								FNPT	1.00	25.4	FNPT
1.00	25.40								MNPT	1.00	25.4	FNPT
291	2000			20.06	137.90	19126M	.75	19.05	MNPT	1.00	25.4	FNPT
							.75	19.05	FNPT	1.00	25.4	FNPT
							1.00	25.40	MNPT	1.00	25.4	FNPT
2001	8000	137.96	551.58	19126H	.75	19.05	FNPT	1.00	25.4	FNPT		
0.226	1.458	5	290	0.34	19.99	19226L	1.00	25.40	MNPT	1.50	38.1	FNPT
							1.00	25.40	FNPT	1.50	38.1	FNPT
		291	2000	20.06	137.90	19226M	1.00	25.40	MNPT	1.50	38.1	FNPT
							1.00	25.40	FNPT	1.50	38.1	FNPT
		2001	6400	137.96	441.26	19226H	1.00	25.40	FNPT	1.50	38.1	FNPT
		0.357	2.303	5	290	0.34	19.99	19357L	1.50	38.10	FNPT	2.00
291	1500			20.06	103.42	19357M	1.50	38.10	FNPT	2.00	50.8	FNPT
0.567	3.658	5	290	0.34	19.99	19567L	2.00	50.80	FNPT	2.50	63.5	FNPT
		291	1000	20.06	68.95	19567M	2.00	50.80	FNPT	2.50	63.5	FNPT

Materials

19000 Metal Seat Valve

19000-2 Threaded End Connection

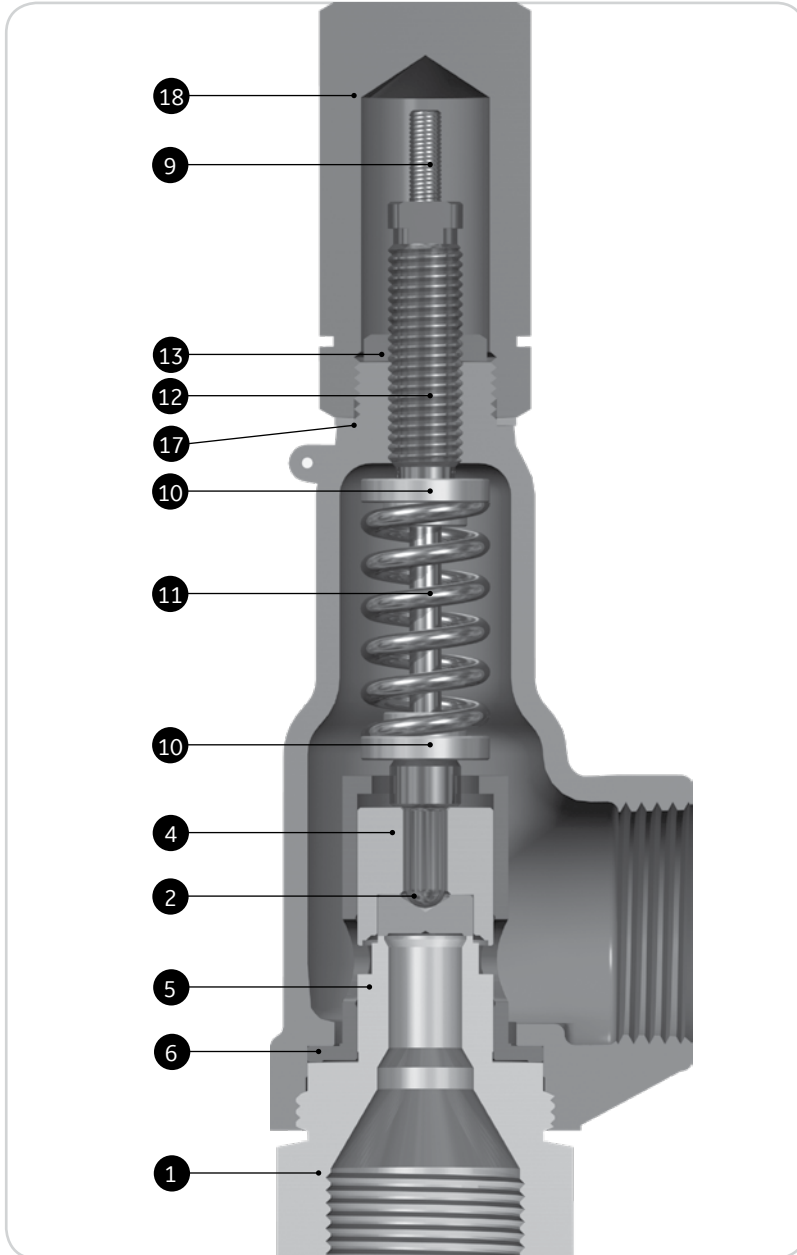

Note: Extension, flange and nipples for flanged and socket-weld connections are not shown.

Packed Lever

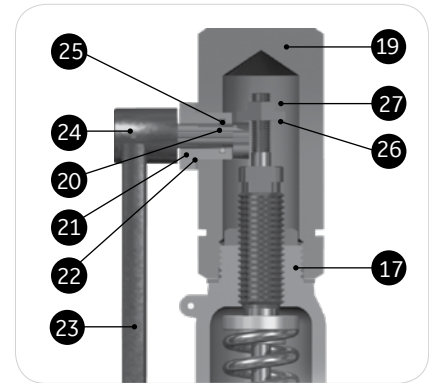

Plain Lever

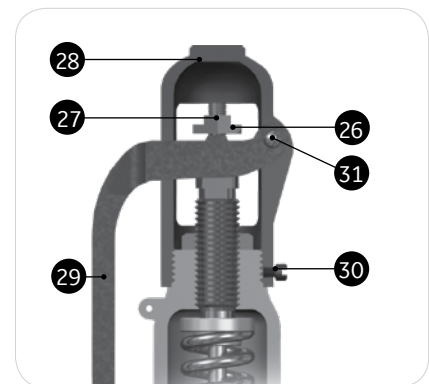

Cap with Gag

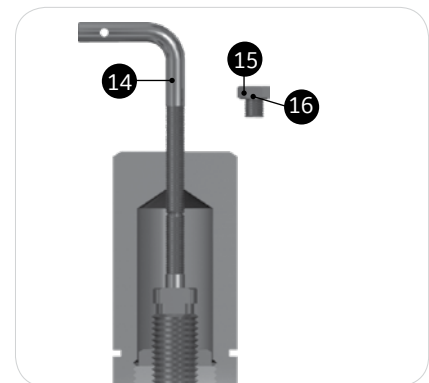

Materials

19000 Metal Seat Valve

19000 Metal Seat Valve - Std. Materials		
Ref. No.	Part	Material (-CC)
1	Base	
	19000L	ASME SA479 316 St. St.
	19000M	ASME SA479 316 St. St.
	19000H	ASME SA479 316 St. St. ¹
2	Disc	
	19000L & M	316 Stainless Steel
	19000L & M (Steam) ²	616 Stainless Steel
	19000H	Inconel X-750
4	Disc Holder	
	Metal Seat 19000L	316 Stainless Steel
	Metal Seat 19000M	316 Stainless Steel
	Metal Seat 19000H	316 Stainless Steel
5	Guide	316 Stainless Steel
6	Bonnet	ASME SA216 WCC CS
9	Spindle	
	Metal Seat 19000L	316 Stainless Steel
	Metal Seat 19000M	316 Stainless Steel
	Metal Seat 19000H	Inconel X-750
10	Spring Washer	Carbon Steel
11	Spring	
	19000Lc	17-7 PH Stainless Steel
	19000Lt	Inconel X-750
	19000Mc	17-7 PH Stainless Steel
	19000Mt	Inconel X-750
	19000Hc	17-7 PH Stainless Steel
19000Ht	Inconel X-750	
12	Adjusting Screw	316 Stainless Steel
13	Adjusting Screw Locknut	316 Stainless Steel
14	Gag Bolt	Carbon Steel
15	Sealing Plug	Carbon Steel
16	Sealing Plug Gasket	Soft Iron
17	Cap Gasket	Soft Iron
18	Screwed Cap	Carbon Steel
19	Packed Cap	Carbon Steel
20	Cam Shaft	410 Stainless Steel
21	Bushing	416 Stainless Steel
22	Bushing Gasket	Soft Iron
23	Packed Lifting Lever	Malleable Iron
24	Drive Pin	Steel (Ni-Plated)
25	O-Ring	Viton 70
26	Release Nut	Carbon Steel
27	Release Locknut	Carbon Steel
28	Plain Lever Cap	Malleable Iron
29	Plain Lifting Lever	Malleable Iron
30	Cap Screw	Carbon Steel
31	Lever Pin	Carbon Steel
32	Inlet Extension (Not Shown)	316 Stainless Steel
33	Inlet Flange (Not Shown)	ASME SA105 Carbon Steel
34	Outlet Extension (Not Shown)	316 Stainless Steel
35	Outlet Flange (Not Shown)	ASME SA105 Carbon Steel
41	Inlet Nipple Extension (Optional)	316 Stainless Steel
42	Outlet Nipple Extension (Optional)	Carbon Steel

NACE Material Variations

N1 material variation is the same as the CC material variation, except for all springs, which will be Inconel X750, and the disc material for applications where the temperature is $\geq 251^{\circ}\text{F}$ or steam, which will be Inconel X750.

N2 material variation is the same as the S4 material variation, except the disc material for applications where the temperature is $\geq 251^{\circ}\text{F}$ or steam, which will be Inconel X750. All disc holders and springs will be Inconel X750.

Notes:

1. Stellite or equivalent seats.
2. Supplied for steam service at and above 251°F (122°C).

Materials

19096-MBP

19096MBP

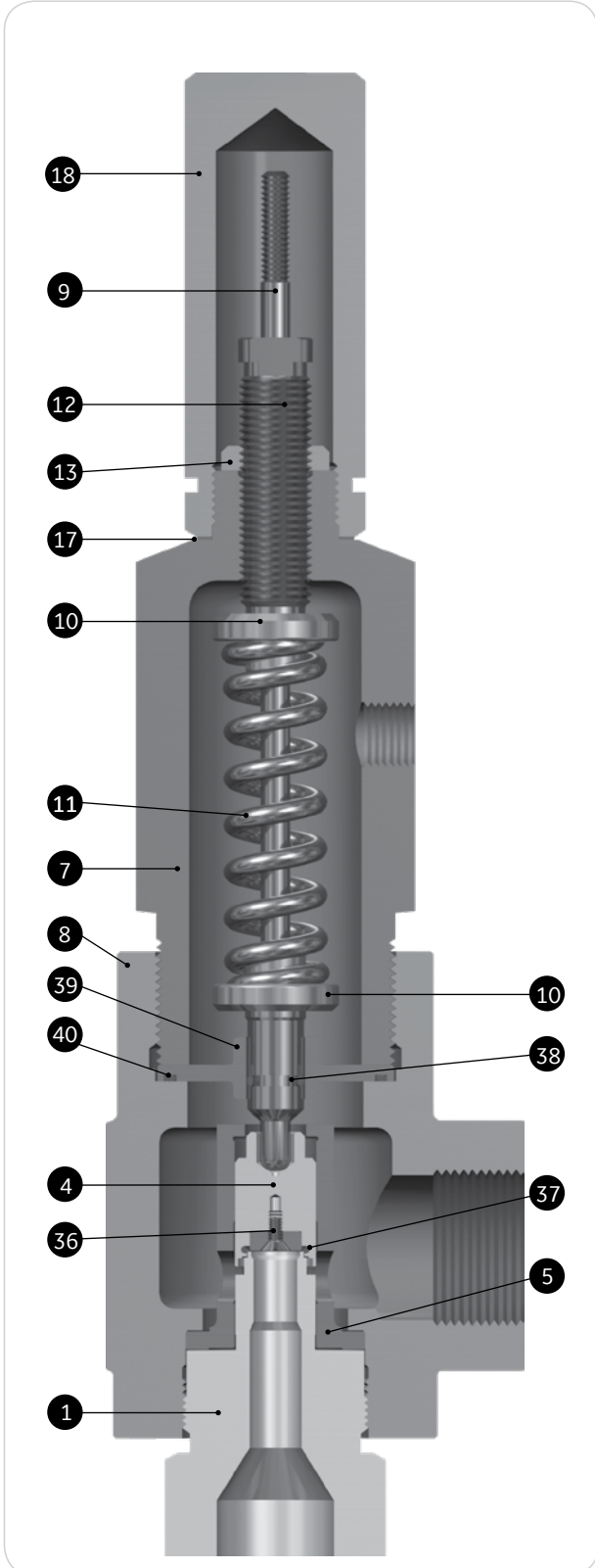

19000DA

19000DA

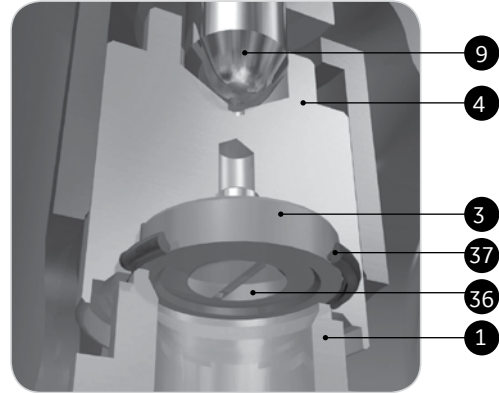

Plain Lever

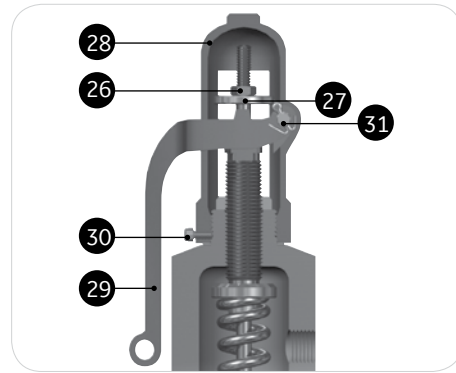

Cap with Gag

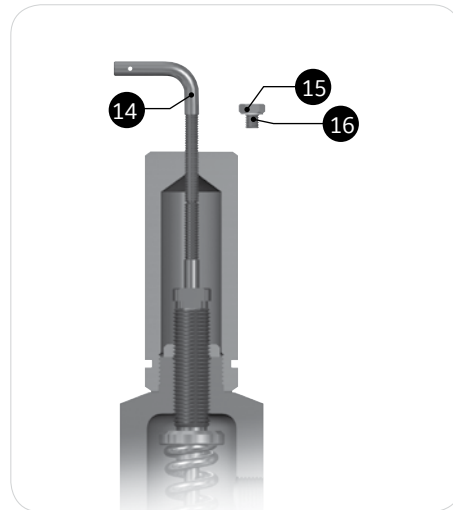

Materials

19096-MBP

19096-MBP - Std. Materials		
Ref. No.	Part	Material (-CC)
1	Base	
	19000L	ASME SA479 316 St.St.
	19000M	ASME SA479 316 St.St.
	19000H	ASME SA479 316 St.St. ¹
3	O-Ring Retainer	
	19000L	316 Stainless Steel
	19000M	316 Stainless Steel
	19000H	316 Stainless Steel
4	Disc Holder	
	19000L	316 Stainless Steel
	19000M	Inconel X-750
	19000H	Inconel X-750
5	Guide	316 Stainless Steel
7	Bonnet Top	ASME SA105 Carbon Steel
8	Bonnet Bottom	ASME SA105 Carbon Steel
9	Spindle	
	19000L	316 Stainless Steel
	19000M	Inconel X-750
	19000H	Inconel X-750
10	Spring Washer	Carbon Steel
11	Spring	
	19000Mc	17-7 PH Stainless Steel
	19000Mt	Inconel X-750
12	Adjusting Screw	316 Stainless Steel
13	Adj. Screw Locknut	316 Stainless Steel
14	Gag Bolt	Carbon Steel
15	Sealing Plug	Carbon Steel
16	Sealing Plug Gasket	Soft Iron
17	Cap Gasket	Soft Iron
18	Screwed Cap	Carbon Steel
26	Release Nut	Carbon Steel
27	Release Locknut	Carbon Steel
28	Plain Lever Cap	Malleable Iron
29	Plain Lifting Lever	Malleable Iron
30	Cap Screw	Carbon Steel
31	Lever Pin	Carbon Steel
32	Inlet Extension (Not Shown)	316 Stainless Steel
33	Inlet Flange (Not Shown)	ASME SA105 Carbon Steel
34	Outlet Extension (Not Shown)	316 Stainless Steel
35	Outlet Flange (Not Shown)	ASME SA105 Carbon Steel
36	O-Ring Retainer Lockscrew	316 Stainless Steel
37	O-Ring Seat Seal	Select
38	Spindle O-Ring	Same as O-Ring Seat Seal ²
39	Backup Plate	316 Stainless Steel
40	Backup Plate O-Ring	Same as O-Ring Seat Seal
41	Inlet Nipple Extension (Optional)	316 Stainless Steel
42	Outlet Nipple Extension (Optional)	Carbon Steel

NACE Material Variations

N1 material variation will be the same as the CC material variation, except for the spring, which will be Inconel X750.

N2 material variation will be the same as the S4 material variation, except for the spring, which will be Inconel X750.

Soft Seat Material Temp. Limits				
Material	Temperature Limits			
	°F		°C	
	min.	max.	min.	max.
Nitrile	-45	+300	-43	+149
Ethylene/Propylene	-70	+500	-57	+260
Fluoro-Carbon	-15	+400	-26	+204
Fluoro-Silicone	-100	+350	-73	+177
Neoprene	-45	+300	-43	+149
Silicone	-65	+437	-54	+225
Teflon	-300	+505	-184	+263

19000DA - Std. Materials		
Ref. No.	Part	Material (-CC)
1	Base	
	19000L	ASME SA479 316 St.St.
	19000M	ASME SA479 316 St.St.
	19000H	ASME SA479 316 St.St. ¹
3	O-Ring Retainer	
	19000L	316 Stainless Steel
	19000M	316 Stainless Steel
	19000H	316 Stainless Steel
4	Disc Holder	
	19000L	316 Stainless Steel
	19000M	Inconel X-750
	19000H	Inconel X-750
9	Spindle	
	19000L	316 Stainless Steel
	19000M	Inconel X-750
	19000H	Inconel X-750
36	O-Ring Retainer Lockscrew	316 Stainless Steel
37	O-Ring Seat Seal	Select

Notes:

1. Stellite or equivalent seats.
2. Not to be Teflon.

Materials

Corrosive Service Materials

Stainless Material Variations (Standard & Backpressure Design)			
Part	Stainless Steel Valve Construction		
	S2	S3	S4
Base			
19000L, 19000M	ASME SA479 316 St. St.	ASME SA479 316 St. St.	ASME SA479 316 St. St.
19000H	ASME SA479 316 St. St. ¹	ASME SA479 316 st. St. ¹	ASME SA479 316 St. St. ¹
Disc (MS)			
19000L & M	316 Stainless Steel	316 Stainless Steel	316 Stainless Steel
19000L & M (Steam) ²	616 Stainless Steel	616 Stainless Steel	616 Stainless Steel
19000H	Inconel X-750	Inconel X-750	Inconel X-750
O-Ring Retainer (DA & BP)			
19000L, 19000M	316 Stainless Steel	316 Stainless Steel	316 Stainless Steel
19000H	Inconel X-750	Inconel X-750	Inconel X-750
Disc Holder (BP-Soft Seat Only)			
Metal Seat; 19000L, 19000M, 19000H, Soft Seat; 19000L	316 Stainless Steel	316 Stainless Steel	316 Stainless Steel
Soft Seat; 19000M, 19000H	Inconel X-750	Inconel X-750	Inconel X-750
Guide, Outlet Extension	316 Stainless Steel	316 Stainless Steel	316 Stainless Steel
Bonnet (DA & MS)	ASME SA216 WCC CS	ASME SA351 CF8M St. St.	ASME SA351 CF8M St. St.
Bonnet Top & Bonnet Bottom (BP Only)	ASME SA105 Carbon Steel	ASME SA479 316 St. St.	ASME SA479 316 St. St.
Spindle (BP-Soft Seat Only)			
Metal Seat; 19000L, 19000M, Soft Seat; 19000L	316 Stainless Steel	316 Stainless Steel	316 Stainless Steel
Metal Seat; 19000H, Soft Seat; 19000M, 19000H	Inconel X-750	Inconel X-750	Inconel X-750
Spring Washer	Carbon Steel	Carbon Steel	316 Stainless Steel
Spring (BP-19000M Only)			
19000Lc	17-7 PH Stainless Steel	17-7 PH Stainless Steel	316 Stainless Steel
19000Lt, 19000Mt, 19000Ht	Inconel X-750	Inconel X-750	Inconel X-750
19000Mc, 19000Hc	17-7 PH Stainless Steel	17-7 PH Stainless Steel	Inconel X-750
Adjusting Screw, Adj. Screw Locknut	316 Stainless Steel	316 Stainless Steel	316 Stainless Steel
Gag Bolt, Sealing Plug	Carbon Steel	316 Stainless Steel	316 Stainless Steel
Sealing Plug Gasket, Cap Gasket, Bushing Gasket	Soft Iron	Monel	Monel
Screwed Cap, Packed Cap, Cap Screw	Carbon Steel	316 Stainless Steel	316 Stainless Steel
Cam Shaft	410 Stainless Steel	316 Stainless Steel	316 Stainless Steel
Bushing	416 Stainless Steel	316 Stainless Steel	316 Stainless Steel
Packed Lifting Lever	Malleable Iron	316 Stainless Steel	316 Stainless Steel
Drive Pin	Steel (Ni-Plated)	303 Stainless Steel	303 Stainless Steel
O-Ring	Viton 70	Viton 70	Viton 70
Release Nut, Release Locknut, Lever Pin	Carbon Steel	316 Stainless Steel	316 Stainless Steel
Plain Lever Cap, Plain Lifting Lever	Malleable Iron	316 Stainless Steel	316 Stainless Steel
Inlet Extension, Inlet Nipple Extension (Optional)	316 Stainless Steel	316 Stainless Steel	316 Stainless Steel
Inlet Flange	ASME SA105 Carbon Steel	ASME SA182-F316 ³	ASME SA182-F316 ³
Outlet Nipple Extension (Optional)	Carbon Steel	316 Stainless Steel	316 Stainless Steel
Outlet Flange	ASME SA105 Carbon Steel	ASME SA182-F316 ³	ASME SA182-F316 ³
Backup Plate, O-Ring Retainer Lockscrew	316 Stainless Steel	316 Stainless Steel	316 Stainless Steel
O-Ring Seat Seal, Backup Plate O-Ring, Spindle O-Ring ⁴	Select	Select	Select

Notes

1. Stellite or equivalent seats.
2. Supplied for steam service at and above 251°F (122°C).
3. or SA479-316 Stainless Steel.
4. Not to be Teflon.

Materials

Corrosive Service Materials

Monel Material Variations (Standard & Backpressure Design)					
Part	Monel Valve Construction				
	M1	MB	M2	M3	M4
Base					
19000L, 19000M	Monel	Monel	Monel	Monel	Monel
19000H	Inconel 625 ¹	Inconel 625 ¹	Inconel 625 ¹	Inconel 625 ¹	Inconel 625 ¹
Disc (MS)					
19000L & M	Monel	Monel	Monel	Monel	Monel
19000L & M (Steam) ² , 19000H	Inconel X-750	Inconel X-750	Inconel X-750	Inconel X-750	Inconel X-750
O-Ring Retainer (DA & BP)					
19000L, 19000M	Monel	Monel	Monel	Monel	Monel
19000H	Inconel X-750	Inconel X-750	Inconel X-750	Inconel X-750	Inconel X-750
Disc Holder (BP-Soft Seat Only)					
Metal Seat; 19000L, 19000M, 19000H	316 Stainless Steel	Monel	Monel	Monel	Monel
Soft Seat; 19000L	Monel	Monel	Monel	Monel	Monel
Soft Seat; 19000M, 19000H	Inconel X-750	Inconel X-750	Inconel X-750	Inconel X-750	Inconel X-750
Guide	316 Stainless Steel	316 Stainless Steel	316 Stainless Steel	316 Stainless Steel	316 Stainless Steel
One Piece Bonnet (DA & MS)	ASME SA216 WCC CS	ASME SA216 WCC CS	ASME SA216 WCC CS	ASTM A494 M35-1 NiCu Alloy	ASTM A494 M35-1 NiCu Alloy
Bonnet Top & Bonnet Bottom (BP Only)	ASME SA105 CS	ASME SA105 CS	ASME SA105 CSI	ASME SB164-N04400	ASME SB164-N04400
Spindle (BP-Soft Seat Only)					
Metal Seat; 19000L, 19000M	316 Stainless Steel	316 Stainless Steel	Monel	Monel	Monel
Metal Seat; 19000H Soft Seat; 19000M, 19000H	Inconel X-750	Inconel X-750	Inconel X-750	Inconel X-750	Inconel X-750
Soft Seat; 19000L	316 Stainless Steel	316 Stainless Steel	Monel	Monel	Monel
Spring Washer	Carbon Steel	Carbon Steel	Carbon Steel	Carbon Steel	Monel
Spring (BP-19000M Only)					
19000Lc, 19000Mc, 19000Hc	17-7 PH St. St.	17-7 PH St. St.	17-7 PH St. St.	17-7 PH St. St.	Monel
19000Lt, 19000Mt, 19000Ht	Inconel X-750	Inconel X-750	Inconel X-750	Inconel X-750	Inconel X-750
Adjusting Screw, Adj. Screw Locknut	316 Stainless Steel	316 Stainless Steel	316 Stainless Steel	Monel	Monel
Gag Bolt	Carbon Steel	Carbon Steel	Carbon Steel	316 Stainless Steel	316 Stainless Steel
Sealing Plug, Screwed Cap	Carbon Steel	Carbon Steel	Carbon Steel	Monel	Monel
Sealing Plug Gasket, Cap Gasket	Soft Iron	Soft Iron	Soft Iron	Monel	Monel
Packed Cap	Carbon Steel	Carbon Steel	Carbon Steel	N/A	N/A
Cam Shaft	410 Stainless Steel	410 Stainless Steel	410 Stainless Steel	N/A	N/A
Bushing	416 Stainless Steel	416 Stainless Steel	416 Stainless Steel	N/A	N/A
Bushing Gasket	Soft Iron	Soft Iron	Soft Iron	N/A	N/A
Packed Lifting Lever	Malleable Iron	Malleable Iron	Malleable Iron	N/A	N/A
Drive Pin	Steel (Ni-Plated)	Steel (Ni-Plated)	Steel (Ni-Plated)	N/A	N/A
O-Ring	Viton 70	Viton 70	Viton 70	N/A	N/A
Release Nut, Release Locknut	Carbon Steel	Carbon Steel	Carbon Steel	N/A	N/A
Plain Lever Cap, Plain Lifting Lever	Malleable Iron	Malleable Iron	Malleable Iron	N/A	N/A
Cap Screw, Lever Pin	Carbon Steel	Carbon Steel	Carbon Steel	N/A	N/A
Inlet Extension	Monel	Monel	Monel	Monel	Monel
Inlet Flange, Outlet Flange	ASME SA105 CS	ASME SA105 CS	ASME SA105 CS	ASME SB564 ³	ASME SB564 ³
Outlet Ext., Outlet Nipple Ext. (Optional)	316 Stainless Steel	316 Stainless Steel	316 Stainless Steel	Monel	Monel
O-Ring Retainer Lockscrew	Monel	Monel	Monel	Monel	Monel
O-Ring Seat Seal, Backup Plate O-Ring, Spindle O-Ring ⁴	Select	Select	Select	Select	Select
Backup Plate, Inlet Nipple Ext. (Optional)	Monel	Monel	Monel	Monel	Monel

Notes:

1. Stellite or equivalent seats.
2. Supplied for steam service at and above 251°F (122°C).
3. SB164-N04400.
4. Not to be Teflon.

Materials

Corrosive Service Materials

Hastelloy Material Variations (Standard & Backpressure Design)				
Part	Hastelloy Valve Construction			
	H1	H2	H3	H4
Base				
19000L, 19000M	Hastelloy	Hastelloy	Hastelloy	Hastelloy
19000H	Inconel 625 ¹	Inconel 625 ¹	Inconel 625 ¹	Inconel 625 ¹
Disc (MS)				
19000L & M	Hastelloy	Hastelloy	Hastelloy	Hastelloy
19000L & M (Steam) ² , 19000H	Inconel X-750	Inconel X-750	Inconel X-750	Inconel X-750
O-Ring Retainer (DA & BP)				
19000L, 19000M	Hastelloy	Hastelloy	Hastelloy	Hastelloy
19000H	Inconel X-750	Inconel X-750	Inconel X-750	Inconel X-750
Disc Holder (BP-Soft Seat Only)				
Metal Seat; 19000L, 19000M, 19000H	316 Stainless Steel	Hastelloy	Hastelloy	Hastelloy
Soft Seat; 19000L	Hastelloy	Hastelloy	Hastelloy	Hastelloy
Soft Seat; 19000M, 19000H	Inconel X-750	Inconel X-750	Inconel X-750	Inconel X-750
Guide	316 Stainless Steel	Hastelloy	Hastelloy	Hastelloy
Bonnet (DA & MS)	ASME SA216 WCC Carbon Steel	ASME SA216 WCC Carbon Steel	ASME SA194 CW12MW NA ³	ASME SA194 CW12MW NA ³
Bonnet Top & Bonnet Bottom (BP Only)	ASME SA105 Carbon Steel	ASME SA105 Carbon Steel	ASME SB574-N10276	ASME SB574-N10276
Spindle (BP-Soft Seat Only)				
Metal Seat; 19000L, 19000M	316 Stainless Steel	Hastelloy	Hastelloy	Hastelloy
Metal Seat; 19000H, Soft Seat; 19000M, 19000H	Inconel X-750	Inconel X-750	Inconel X-750	Inconel X-750
Soft Seat; 19000L	316 Stainless Steel	Hastelloy	Hastelloy	Hastelloy
Spring Washer	Carbon Steel	Carbon Steel	Carbon Steel	Hastelloy
Spring (BP-19000M Only)				
19000Lc	17-7 PH Stainless Steel	17-7 PH Stainless Steel	17-7 PH Stainless Steel	Hastelloy
19000Lt, 19000Mt, 19000Ht	Inconel X-750	Inconel X-750	Inconel X-750	Inconel X-750
19000Mc, 19000Hc	17-7 PH Stainless Steel	17-7 PH Stainless Steel	17-7 PH Stainless Steel	Inconel X-750
Adjusting Screw, Adj. Screw Locknut	316 Stainless Steel	316 Stainless Steel	Hastelloy	Hastelloy
Gag Bolt	Carbon Steel	Carbon Steel	316 Stainless Steel	316 Stainless Steel
Sealing Plug, Screwed Cap	Carbon Steel	Carbon Steel	Hastelloy	Hastelloy
Sealing Plug Gasket, Cap Gasket	Soft Iron	Soft Iron	Monel	Monel
Packed Cap, Cap Screw, Lever Pin	Carbon Steel	Carbon Steel	N/A	N/A
Cam Shaft	410 Stainless Steel	410 Stainless Steel	N/A	N/A
Bushing	416 Stainless Steel	416 Stainless Steel	N/A	N/A
Bushing Gasket	Soft Iron	Soft Iron	N/A	N/A
Packed Lifting Lever, Plain Lifting Lever	Malleable Iron	Malleable Iron	N/A	N/A
Drive Pin	Steel (Ni-Plated)	Steel (Ni-Plated)	N/A	N/A
O-Ring	Viton 70	Viton 70	N/A	N/A
Release Nut, Release Locknut	Carbon Steel	Carbon Steel	N/A	N/A
Plain Lever Cap	Malleable Iron	Malleable Iron	N/A	N/A
Inlet Ext., Inlet Nipple Ext. (Optional)	Hastelloy	Hastelloy	Hastelloy	Hastelloy
Inlet Flange, Outlet Flange	ASME SA105 Carbon Steel	ASME SA105 Carbon Steel	ASME SB574-N10276	ASME SB574-N10276
Outlet Ext., Outlet Nipple Ext. (Optional)	316 Stainless Steel	316 Stainless Steel	Hastelloy	Hastelloy
O-Ring Retainer Lockscrew (DA & BP)	Hastelloy	Hastelloy	Hastelloy	Hastelloy
O-Ring Seat Seal Spindle O-Ring, Backup Plate O-Ring ⁴	Select	Select	Select	Select
Backup Plate (BP Only)	Hastelloy	Hastelloy	Hastelloy	Hastelloy

Notes:

1. Stellite or equivalent seats.
2. Supplied for steam service at and above 251°F (122°C).
3. For flanged 19000 valves, bonnets must be made from barstock ASME SB574 UNS N10276.
4. Not to be Teflon.

Materials

Corrosive Service Materials

Alloy 20 Material Variations (Standard and Backpressure Design)				
Part	Alloy 20 Valve Construction			
	A1	A2	A3	A4
Base				
19000L, 19000M	Alloy 20	Alloy 20	Alloy 20	Alloy 20
19000H	Inconel 625 ¹	Inconel 625 ¹	Inconel 625 ¹	Inconel 625 ¹
Disc (MS)				
19000L & M	Alloy 20	Alloy 20	Alloy 20	Alloy 20
19000L & M (Steam) ² , 19000H	Inconel X-750	Inconel X-750	Inconel X-750	Inconel X-750
O-Ring Retainer (DA & BP)				
19000L, 19000M	Alloy 20	Alloy 20	Alloy 20	Alloy 20
19000H	Inconel X-750	Inconel X-750	Inconel X-750	Inconel X-750
Disc Holder (BP-Soft Seat Only)				
Metal Seat; 1900L, 1900M, 1900H	316 Stainless Steel	Alloy 20	Alloy 20	Alloy 20
Soft Seat; 19000L	Alloy 20	Alloy 20	Alloy 20	Alloy 20
Soft Seat; 19000M, 19000H	Inconel X-750	Inconel X-750	Inconel X-750	Inconel X-750
Guide	316 Stainless Steel	Alloy 20	Alloy 20	Alloy 20
Bonnet (DA & MS)	ASME SA216 WCC CS	ASME SA216 WCC CS	ASME SA351 CN7M	ASME SA351 CN7M
Bonnet Top & Bonnet Bottom (BP Only)	ASME SA105 Carbon Steel	ASME SA105 Carbon Steel	ASTM B473 N08020	ASTM B473 N08020
Spindle (BP-Soft Seat Only)				
Metal Seat; 1900L, 1900M, Soft Seat; 19000L	316 Stainless Steel	Alloy 20	Alloy 20	Alloy 20
Metal Seat; 1900H, Soft Seat; 19000M, 19000H	Inconel X-750	Inconel X-750	Inconel X-750	Inconel X-750
Spring Washer	Carbon Steel	Carbon Steel	Carbon Steel	Alloy 20
Spring (BP-19000M Only)				
19000Lc	17-7 PH Stainless Steel	17-7 PH Stainless Steel	17-7 PH Stainless Steel	Alloy 20
19000Lt, 19000Mt, 19000Ht	Inconel X-750	Inconel X-750	Inconel X-750	Inconel X-750
19000Mc, 19000Hc	17-7 PH Stainless Steel	17-7 PH Stainless Steel	17-7 PH Stainless Steel	Inconel X-750
Adjusting Screw, Adj. Screw Locknut	316 Stainless Steel	316 Stainless Steel	Alloy 20	Alloy 20
Gag Bolt	Carbon Steel	Carbon Steel	316 Stainless Steel	316 Stainless Steel
Sealing Plug, Screwed Cap	Carbon Steel	Carbon Steel	Alloy 20	Alloy 20
Sealing Plug Gasket, Cap Gasket	Soft Iron	Soft Iron	Monel	Monel
Packed Cap, Cap Screw, Lever Pin	Carbon Steel	Carbon Steel	N/A	N/A
Cam Shaft	410 Stainless Steel	410 Stainless Steel	N/A	N/A
Bushing	416 Stainless Steel	416 Stainless Steel	N/A	N/A
Bushing Gasket	Soft Iron	Soft Iron	N/A	N/A
Packed Lifting Lever, Plain Lifting Lever	Malleable Iron	Malleable Iron	N/A	N/A
Drive Pin	Steel (Ni-Plated)	Steel (Ni-Plated)	N/A	N/A
O-Ring	Viton 70	Viton 70	N/A	N/A
Release Nut, Release Locknut	Carbon Steel	Carbon Steel	N/A	N/A
Plain Lever Cap	Malleable Iron	Malleable Iron	N/A	N/A
Inlet Ext., Inlet Nipple Ext. (Optional)	Alloy 20	Alloy 20	Alloy 20	Alloy 20
Inlet Flange, Outlet Flange	ASME SA105 Carbon Steel	ASME SA105 Carbon Steel	ASME SB462 ³	ASME SB462 ³
Outlet Ext., Outlet Nipple Ext. (Optional)	316 Stainless Steel	316 Stainless Steel	Alloy 20	Alloy 20
O-Ring Retainer Lockscrew (DA & BP)	Alloy 20	Alloy 20	Alloy 20	Alloy 20
O-Ring Seat Seal (DA & BP), Backup Plate O-Ring Spindle O-Ring (BP Only) ⁴	Select	Select	Select	Select
Backup Plate (BP Only)	Alloy 20	Alloy 20	Alloy 20	Alloy 20

Notes:

1. Stellite or equivalent seats.
2. Supplied for steam service at and above 251°F (122°C).
3. or SB473-N08020.
4. Not to be Teflon.

Materials

Corrosive Service Materials

Duplex Material Variations (Standard & Backpressure Design)				
Part	Duplex Valve Construction ¹			
	D1	D2	D3	D4
Base				
19000L, 19000M	Duplex	Duplex	Duplex	Duplex
19000H	Duplex ²	Duplex ²	Duplex ²	Duplex ²
Disc (MS)				
19000L & M	Duplex	Duplex	Duplex	Duplex
19000L & M (Steam) ³ , 19000H	Inconel X-750	Inconel X-750	Inconel X-750	Inconel X-750
O-Ring Retainer (DA & BP)				
19000L, 19000M	Duplex	Duplex	Duplex	Duplex
19000H	Inconel X-750	Inconel X-750	Inconel X-750	Inconel X-750
Disc Holder (BP-Soft Seat Only)				
Metal Seat; 19000L, 19000M, 19000H	316 Stainless Steel	Duplex	Duplex	Duplex
Soft Seat; 19000L	Duplex	Duplex	Duplex	Duplex
Soft Seat; 19000M, 19000H	Inconel X-750	Inconel X-750	Inconel X-750	Inconel X-750
Guide	316 Stainless Steel	Duplex	Duplex	Duplex
Bonnet (DA & MS)	ASME SA216 WCC Carbon St.	ASME SA216 WCC Carbon St.	Duplex	Duplex
Bonnet Top & Bonnet Bottom (BP Only)	ASME SA105 Carbon St.	ASME SA105 Carbon St.	Duplex	Duplex
Spindle (BP-Soft Seat Only)				
Metal Seat: 19000L, 19000M; Soft Seat: 19000L	316 Stainless Steel	Duplex	Duplex	Duplex
Metal Seat: 19000H; Soft Seat: 19000M, 19000H	Inconel X-750	Inconel X-750	Inconel X-750	Inconel X-750
Spring Washer	Carbon Steel	Carbon Steel	Carbon Steel	Duplex
Spring (BP-19000M Only)				
19000Lc	17-7 PH Stainless Steel	17-7 PH Stainless Steel	17-7 PH Stainless Steel	Duplex
19000Lt, 19000Mt, 19000Ht	Inconel X-750	Inconel X-750	Inconel X-750	Inconel X-750
19000Mc, 19000Hc	17-7 PH Stainless Steel	17-7 PH Stainless Steel	17-7 PH Stainless Steel	Inconel X-750
Adjusting Screw, Adj. Screw Locknut	316 Stainless Steel	316 Stainless Steel	Duplex	Duplex
Gag Bolt	Carbon Steel	Carbon Steel	316 Stainless Steel	316 Stainless Steel
Sealing Plug, Screwed Cap	Carbon Steel	Carbon Steel	Duplex	Duplex
Sealing Plug Gasket, Cap Gasket	Soft Iron	Soft Iron	Monel	Monel
Packed Cap, Cap Screw, Lever Pin	Carbon Steel	Carbon Steel	N/A	N/A
Cam Shaft	410 Stainless Steel	410 Stainless Steel	N/A	N/A
Bushing	416 Stainless Steel	416 Stainless Steel	N/A	N/A
Bushing Gasket	Soft Iron	Soft Iron	N/A	N/A
Packed Lifting Lever, Plain Lifting Lever	Malleable Iron	Malleable Iron	N/A	N/A
Drive Pin	Steel (Ni-Plated)	Steel (Ni-Plated)	N/A	N/A
O-Ring	Viton 70	Viton 70	N/A	N/A
Release Nut, Release Locknut	Carbon Steel	Carbon Steel	N/A	N/A
Plain Lever Cap	Malleable Iron	Malleable Iron	N/A	N/A
Inlet Extension, Inlet Nipple Ext. (Optional)	Duplex	Duplex	Duplex	Duplex
Inlet Flange, Outlet Flange	ASME SA105 Carbon Steel	ASME SA105 Carbon St.	Duplex	Duplex
Outlet Ext., Outlet Nipple Ext. (Optional)	316 Stainless Steel	316 Stainless Steel	Duplex	Duplex
O-Ring Retainer Lockscrew (DA & BP)	Duplex	Duplex	Duplex	Duplex
O-Ring Seat Seal (DA & BP)	Select	Select	Select	Select
Backup Plate O-Ring (BP Only)	Select	Select	Select	Select
Spindle O-Ring	Select ⁴	Select ⁴	Select ⁴	Select ⁴
Backup Plate (BP Only)	Duplex	Duplex	Duplex	Duplex

Notes:

1. Parts made from castings shall be constructed from ASME SA995 CE8MN Duplex. Parts made from barstock shall be constructed from ASME SA479 UNS S31803 Duplex.
2. Stellite or equivalent seats.
3. Supplied for steam service at and above 251°F (122°C).
4. Not to be Teflon.

Materials

Cryogenic Service Materials

Low Temperature Material Variation (Standard and Backpressure Design) ¹	
Part	Material Variation (-C1)
Base	
19000L, 19000M	ASME SA479 316 Stainless Steel
19000H	ASME SA479 316L Stainless Steel ²
Disc (MS)	
19000L & M	316 Stainless Steel
19000L & M (Steam) ³	616 Stainless Steel
19000H	Inconel X-750
O-Ring Retainer (DA & BP)	
19000L, 19000M, 19000H	316 Stainless Steel
Disc Holder (BP-Soft Seat Only)	
Metal Seat: 19000L, 19000M	316 Stainless Steel
Metal Seat: 19000H, Soft Seat: 19000L	316 Stainless Steel
Soft Seat: 19000M, 19000H	Inconel X-750
Guide, Adjusting Screw, Adj. Screw Locknut	316 Stainless Steel
One Piece Bonnet (DA & MS)	ASME SA352 LCC Carbon Steel
Bonnet Top & Bonnet Bottom (BP Only)	ASME SA479 316 Stainless Steel
Spindle (BP-Soft Seat Only)	
Metal Seat: 19000L, 19000M; Soft Seat: 19000L	316 Stainless Steel
Metal Seat: 19000H; Soft Seat: 19000M, 19000H	Inconel X-750
Spring Washer, Screwed Cap, Packed Cap	316 Stainless Steel
Spring (BP-19000M Only)	
19000Lc, 19000Mc, 19000Hc	17-7 PH Stainless Steel
19000Lt, 19000Mt, 19000Ht	Inconel X-750
Gag Bolt, Sealing Plug, Cap Screw	Carbon Steel
Sealing Plug Gasket, Cap Gasket	Soft Iron
Cam Shaft	410 Stainless Steel
Bushing	416 Stainless Steel
Bushing Gasket	Soft Iron
Packed Lifting Lever, Plain Lifting Lever	Malleable Iron
Drive Pin	Steel (Ni-Plated)
O-Ring	EPR-70
Release Nut, Release Locknut, Lever Pin	Carbon Steel
Plain Lever Cap	Malleable Iron
Inlet Extension, Inlet Nipple Extension (Optional)	316 Stainless Steel
Inlet Flange	ASME SA182-F316 or SA479-316 St. St.
Outlet Nipple Extension (Optional)	Carbon Steel
Outlet Extension, O-Ring Retainer Lockscrew (DA & BP)	316 Stainless Steel
Backup Plate (BP Only)	316 Stainless Steel
Outlet Flange	ASME SA182-F316 or SA479-316 St. St.
O-Ring Seat Seal (DA & BP), Backup Plate O-Ring (BP Only)	Select
Spindle O-Ring (BP Only)	Select ⁴

Notes:

1. Applicable to Ambient Temperatures of -50°F (-45.6°C).
2. Stellite or equivalent seats
3. Supplied for steam service at and above 251°F (122°C).
4. Not to be Teflon.

Materials

Cryogenic Service Materials

Low Temperature Material Variation (Standard Design only) ¹	
Part	Material Variation (-L3)
Base	
19000L, 19000M	ASME SA479 316 Stainless Steel
19000H	ASME SA479 316 Stainless Steel, Stellite or Equivalent Seats
Disc (MS)	
19000L & M	316 Stainless Steel ²
Disc Holder	
Metal Seat: 1900L, 1900M	316 Stainless Steel ²
Guide, Adj. Screw Locknut	316 Stainless Steel
One Piece Bonnet (DA & MS)	ASME SA351 CF8M Stainless Steel
Spindle	
Metal Seat: 1900L, 1900M	316 Stainless Steel ²
Spring Washer	316 Stainless Steel ²
Spring	
19000Lc	316 Stainless Steel
19000Lt, 19000Mc, 19000Mt	Inconel X-750
Adjusting Screw	316 Stainless Steel ²
Gag Bolt, Sealing Plug	316 Stainless Steel
Sealing Plug Gasket, Cap Gasket, Bushing Gasket	Monel
Screwed Cap, Packed Cap, Cam Shaft	316 Stainless Steel
Bushing, Packed Lifting Lever	316 Stainless Steel
Drive Pin	303 Stainless Steel
O-Ring	Viton 70
Release Nut, Release Locknut, Plain Lever Cap	316 Stainless Steel
Plain Lifting Lever, Cap Screw, Lever Pin	316 Stainless Steel
Inlet Extension, Inlet Nipple Extension (Optional)	316 Stainless Steel
Inlet Flange, Outlet Flange	ASME SA182-F316 or SA479-316 Stainless Steel
Outlet Extension, Outlet Nipple Extension (Optional)	316 Stainless Steel

Notes:

1. Applicable to service temperatures of -151°F to -450°F (-102°C to -268°C), such as Cryogenic Service.
2. Titanium Nitrite Coating (TNC) required.

Materials

O-Ring Selection Procedure

In addition to the rating of the valve based on materials and temperatures, it is possible that if the valve is equipped with O-Rings (soft seats), the O-Ring may limit the range of valve application.

The following selection process is simple and straight forward and should yield a satisfactory valve selection.

Use the following steps in the O-Ring selection process:

1. Refer to the Technical Information section in this catalog to select appropriate O-Ring material for service media.
2. Refer to "Table A" (O-Ring Selection - Durometer). Using the valve set pressure, determine the durometer hardness which will be needed.
3. Refer to "Table B". Utilizing the material selected and the durometer hardness selected check the temperature limits of the material.
4. If the selected material is not adequate, select another material and repeat the procedure.

Note: For fire applications use the operating temperature when selecting a material.

Table A: O-Ring Selection - Durometer

Valve Type	O-Ring Durometer												Teflon							
	Set Pressure												Set Pressure							
	50 ¹				70 ¹				90 ²				-300 to 200 °F (-184.4 to 93.3 °C)				201 to 500 °F (93.9 to 260 °C)			
	min.		max.		min.		max.		min.		max.		min.		max.		min.		max.	
	psig	barg	psig	barg	psig	barg	psig	barg	psig	barg	psig	barg	psig	barg	psig	barg	psig	barg	psig	barg
19096	5	0.34	50	3.45	51	3.52	500	34.47	501	34.54	2500	172.37	1400	96.53	5000	344.74	15	1.03	5000	344.74
19110	5	0.34	50	3.45	51	3.52	500	34.47	501	34.54	2500	172.37	1400	96.53	5000	344.74	15	1.03	5000	344.74
19126	5	0.34	50	3.45	51	3.52	500	34.47	501	34.54	2250	155.13	1000	68.95	6000	413.69	15	1.03	6000	413.69
19226	5	0.34	50	3.45	51	3.52	450	31.03	451	31.10	2000	137.90	1000	68.95	6000	413.69	15	1.03	6000	413.69
19357	5	0.34	50	3.45	51	3.52	400	27.58	401	27.65	1500	103.42	-	-	-	-	15	1.03	1500	103.42
19567	5	0.34	50	3.45	51	3.52	400	27.58	401	27.65	1000	68.95	-	-	-	-	15	1.03	1000	68.95

Notes:

1. Maximum set pressure for silicone compounds is half of the maximum value.
2. The E9 62-90D O-Ring can be used in steam service to a lower pressure limit of 15 psig (1.03 barg).

Materials

O-Ring Selection Procedure

Table B: O-Ring Temperature Limits						
Material	Durometer	Description	Temperature Limits			
			min.		max.	
			°F	°C	°F	°C
Nitrile	50	N299-50 or N1009-50	-45	-42	225	107
	70	N674-70	-40	-40	250	121
	90	N552-90	-40	-40	250	121
	70 ¹	N1173-70	-25	-31	300	148
Ethylene/Propylene	50	E981-50	-65	-53	212	100
	70	E603-70	-65	-53	212	100
	75 & 80 ²	E740-75 & E515-80	-70	-56	250	121
	90	E962-90 ³	-70	-56	500	260
	75 ⁴	E962-75	-60	-51	250 / 400	121 / 204
Fluorocarbon	50	V986-50	-15	-26	400	204
	75	V747-75 or V884-75	-15	-26	400	204
	90	V894-90 or V709-90	-15	-26	400	204
Neoprene	50	C267-50	-45	-42	300	148
	70	C944-70 or C873-70	-45	-42	300	148
Silicone	50	S595-50	-65	-53	437	225
	70	S604-70	-65	-53	437	225
Teflon	N/A	Teflon	-300	-184	505	263
Kalrez ⁵	82	1050LF	-4	-20	550	287
	75	4079	-4	-20	600	315
	91	3018	-4	-20	550	287
	65	1058	-4	-20	500	260

Notes:

1. Consult Factory before using. For use with Freon 134A/Ester Oil Service.
2. Set Pressure Ranges per "Table B" For durometer shall apply to these compounds (For Nuclear Service, Radiation Environment.)
3. EPR962-90D can be used in steam service to a lower pressure limit of 15 psig (1.03 barg). A maximum temperature of 500°F (260°C) is possible for steam only.
4. Up to 400°F (204.4°C) for steam applications only.
5. Consult Factory before selecting. (4079 - Not for use in hot water or steam applications.)

Dimensions and Weights

Threaded Connections

19000 Threaded Connections

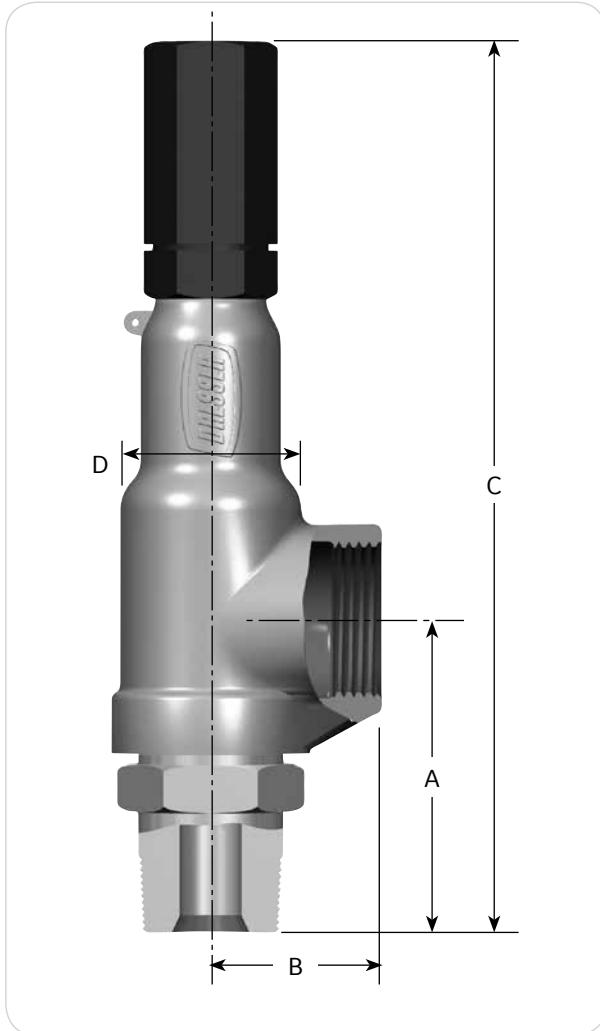

19000MBP Threaded Connections

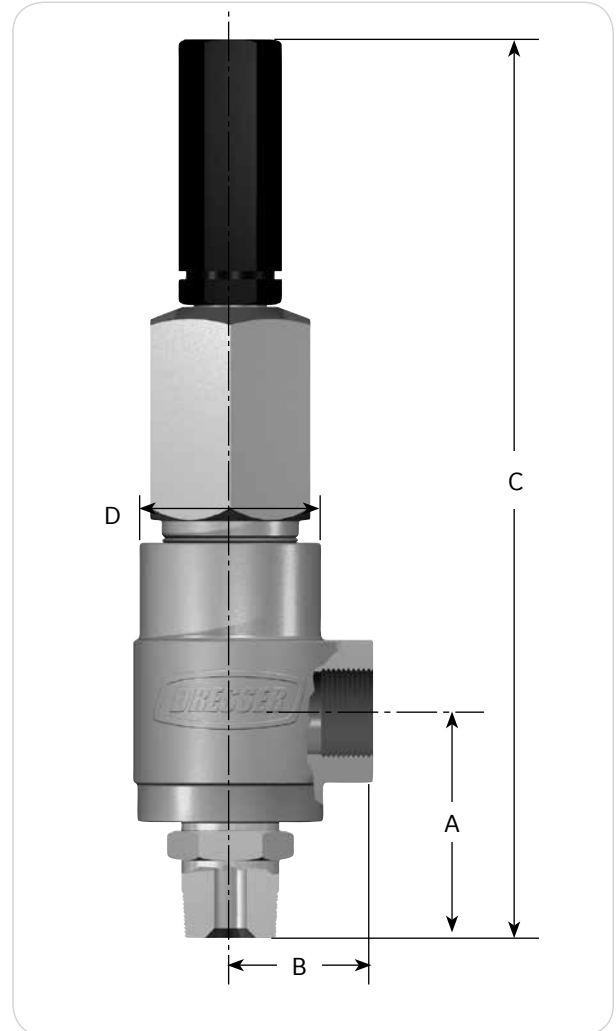

The key to selecting the appropriate dimensions is to use the numbers in the column named “Valve Type”. The “Inlet” column defines the valve by inlet size and connection type, then by outlet size and connection type.

Example: .50 - MNPT x 1.0 - FNPT

Inlet size is .500” (12.70 mm) with a male NPT pipe thread and the outlet is 1” (25.4 mm) size with a female NPT pipe thread. “SW” indicates socket weld. “Flanged Connections” show size of flange and pressure rating.



CAUTION

Do not seal weld inlet and outlet connections.

Dimensions and Weights

Threaded Connections

Threaded Connections (Standard & Backpressure Designs)														
Valve Type	Inlet			Outlet			A		B		C			
	Size		Type ¹	Size		Type ¹					STD		MBP	
	in	mm		in	mm		in	mm	in	mm	in	mm		
19096L	.50	12.7	MNPT	1.00	25.4	FNPT	3.25	82.6	1.88	47.75	10.38	263.7	N/A	N/A
	.75	19.1	MNPT	1.00	25.4	FNPT	3.25	82.6	1.88	47.75	10.38	263.7	N/A	N/A
	.75	19.1	FNPT	1.00	25.4	FNPT	3.13	79.5	1.88	47.75	10.25	260.4	N/A	N/A
	1.00	25.4	MNPT	1.00	25.4	FNPT	3.25	82.6	1.88	47.75	10.38	263.7	N/A	N/A
19096M	.50	12.7	MNPT	1.00	25.4	FNPT	3.25	82.6	2.00	50.80	12.19	309.6	12.88	327.2
	.75	19.1	MNPT	1.00	25.4	FNPT	3.25	82.6	2.00	50.80	12.19	309.6	12.88	327.2
	.75	19.1	FNPT	1.00	25.4	FNPT	3.13	79.5	2.00	50.80	12.06	306.3	12.75	323.9
	1.00	25.4	MNPT	1.00	25.4	FNPT	3.25	82.6	2.00	50.80	12.19	309.6	12.88	327.2
19096H	.75	19.1	FNPT	1.00	25.4	FNPT	3.13	79.5	2.38	60.45	12.50	317.5	N/A	N/A
19110L	.50	12.7	MNPT	1.00	25.4	FNPT	3.25	82.6	1.88	47.75	10.38	263.7	N/A	N/A
	.75	19.1	MNPT	1.00	25.4	FNPT	3.25	82.6	1.88	47.75	10.38	263.7	N/A	N/A
	.75	19.1	FNPT	1.00	25.4	FNPT	3.13	79.5	1.88	47.75	10.25	260.4	N/A	N/A
	1.00	25.4	MNPT	1.00	25.4	FNPT	3.25	82.6	1.88	47.75	10.38	263.7	N/A	N/A
19110M	.50	12.7	MNPT	1.00	25.4	FNPT	3.25	82.6	2.00	50.80	12.19	309.6	N/A	N/A
	.75	19.1	MNPT	1.00	25.4	FNPT	3.25	82.6	2.00	50.80	12.19	309.6	N/A	N/A
	.75	19.1	FNPT	1.00	25.4	FNPT	3.13	79.5	2.00	50.80	12.06	306.3	N/A	N/A
	1.00	25.4	MNPT	1.00	25.4	FNPT	3.25	82.6	2.00	50.80	12.19	309.6	N/A	N/A
19110H	.75	19.1	FNPT	1.00	25.4	FNPT	3.13	79.5	2.38	60.45	12.50	317.5	N/A	N/A
19126L	.75	19.1	MNPT	1.00	25.4	FNPT	3.25	82.6	1.88	47.75	10.38	263.7	N/A	N/A
	.75	19.1	FNPT	1.00	25.4	FNPT	3.13	79.5	1.88	47.75	10.25	260.4	N/A	N/A
	1.00	25.4	MNPT	1.00	25.4	FNPT	3.25	82.6	1.88	47.75	10.38	263.7	N/A	N/A
19126M	.75	19.1	MNPT	1.00	25.4	FNPT	3.25	82.6	2.00	50.80	12.19	309.6	N/A	N/A
	.75	19.1	FNPT	1.00	25.4	FNPT	3.13	79.5	2.00	50.80	12.06	306.3	N/A	N/A
	1.00	25.4	MNPT	1.00	25.4	FNPT	3.25	82.6	2.00	50.80	12.19	309.6	N/A	N/A
19126H	.75	19.1	FNPT	1.00	25.4	FNPT	3.13	79.5	3.13	79.50	15.94	404.9	N/A	N/A
19226L	1.00	25.4	MNPT	1.50	38.1	FNPT	3.63	92.2	2.25	57.15	11.63	295.4	N/A	N/A
	1.00	25.4	FNPT	1.50	38.1	FNPT	3.38	85.9	2.25	57.15	11.38	289.1	N/A	N/A
19226M	1.00	25.4	MNPT	1.50	38.1	FNPT	3.63	92.2	2.38	60.45	13.00	330.2	N/A	N/A
	1.00	25.4	FNPT	1.50	38.1	FNPT	3.38	85.9	2.38	60.45	12.75	323.9	N/A	N/A
19226H	1.00	25.4	FNPT	1.50	38.1	FNPT	3.13	79.5	3.13	79.50	15.94	404.9	N/A	N/A
19357L	1.50	38.1	FNPT	2.00	50.8	FNPT	4.06	103.1	3.13	79.50	15.06	382.5	N/A	N/A
19357M	1.50	38.1	FNPT	2.00	50.8	FNPT	4.06	103.1	3.13	79.50	16.88	428.8	N/A	N/A
19567L	2.00	50.8	FNPT	2.50	63.5	FNPT	4.06	103.1	3.13	79.50	15.06	382.5	N/A	N/A
19567M	2.00	50.8	FNPT	2.50	63.5	FNPT	4.06	103.1	3.13	79.50	16.88	428.8	N/A	N/A

Note:

1. Valves are provided with a male pipe threaded (MNPT) or a female pipe threaded (FNPT) inlet connection.

Dimensions and Weights

Threaded Connections

Threaded Connections (Standard & Backpressure Designs)														
Valve Type	Inlet		Type ¹	Outlet		Type ¹	D				Approx. Weight			
	Size			Size			STD		MBP		STD		MBP	
	in	mm		in	mm		in	mm	in	mm	lb	kg	lb	kg
19096L	.50	12.7	MNPT	1.00	25.4	FNPT	2.00	50.8	N/A	N/A	4.75	2.15	N/A	N/A
	.75	19.1	MNPT	1.00	25.4	FNPT	2.00	50.8	N/A	N/A	4.75	2.15	N/A	N/A
	.75	19.1	FNPT	1.00	25.4	FNPT	2.00	50.8	N/A	N/A	4.50	2.04	N/A	N/A
	1.00	25.4	MNPT	1.00	25.4	FNPT	2.00	50.8	N/A	N/A	4.75	2.15	N/A	N/A
19096M	.50	12.7	MNPT	1.00	25.4	FNPT	2.56	65.0	3.75	95.3	6.50	2.95	11.5	5.22
	.75	19.1	MNPT	1.00	25.4	FNPT	2.56	65.0	3.75	95.3	6.50	2.95	11.5	5.22
	.75	19.1	FNPT	1.00	25.4	FNPT	2.56	65.0	3.75	95.3	6.50	2.95	11.5	5.22
	1.00	25.4	MNPT	1.00	25.4	FNPT	2.56	65.0	3.75	95.3	6.50	2.95	11.5	5.22
19096H	.75	19.1	FNPT	1.00	25.4	FNPT	3.13	79.5	N/A	N/A	11.50	5.22	N/A	N/A
19110L	.50	12.7	MNPT	1.00	25.4	FNPT	2.00	50.8	N/A	N/A	4.75	2.15	N/A	N/A
	.75	19.1	MNPT	1.00	25.4	FNPT	2.00	50.8	N/A	N/A	4.75	2.15	N/A	N/A
	.75	19.1	FNPT	1.00	25.4	FNPT	2.00	50.8	N/A	N/A	4.50	2.04	N/A	N/A
	1.00	25.4	MNPT	1.00	25.4	FNPT	2.00	50.8	N/A	N/A	4.75	2.15	N/A	N/A
19110M	.50	12.7	MNPT	1.00	25.4	FNPT	2.56	65.0	N/A	N/A	6.50	2.95	N/A	N/A
	.75	19.1	MNPT	1.00	25.4	FNPT	2.56	65.0	N/A	N/A	6.50	2.95	N/A	N/A
	.75	19.1	FNPT	1.00	25.4	FNPT	2.56	65.0	N/A	N/A	6.50	2.95	N/A	N/A
	1.00	25.4	MNPT	1.00	25.4	FNPT	2.56	65.0	N/A	N/A	6.50	2.95	N/A	N/A
19110H	.75	19.1	FNPT	1.00	25.4	FNPT	3.13	79.5	N/A	N/A	11.50	5.22	N/A	N/A
19126L	.75	19.1	MNPT	1.00	25.4	FNPT	2.00	50.8	N/A	N/A	5.25	2.38	N/A	N/A
	.75	19.1	FNPT	1.00	25.4	FNPT	2.00	50.8	N/A	N/A	5.00	2.27	N/A	N/A
	1.00	25.4	MNPT	1.00	25.4	FNPT	2.00	50.8	N/A	N/A	5.25	2.38	N/A	N/A
19126M	.75	19.1	MNPT	1.00	25.4	FNPT	2.56	65.0	N/A	N/A	6.50	2.95	N/A	N/A
	.75	19.1	FNPT	1.00	25.4	FNPT	2.56	65.0	N/A	N/A	6.50	2.95	N/A	N/A
	1.00	25.4	MNPT	1.00	25.4	FNPT	2.56	65.0	N/A	N/A	6.50	2.95	N/A	N/A
19126H	.75	19.1	FNPT	1.00	25.4	FNPT	4.63	117.6	N/A	N/A	30.00	13.61	N/A	N/A
19226L	1.00	25.4	MNPT	1.50	38.1	FNPT	2.38	60.5	N/A	N/A	6.75	3.06	N/A	N/A
	1.00	25.4	FNPT	1.50	38.1	FNPT	2.38	60.5	N/A	N/A	6.50	2.95	N/A	N/A
19226M	1.00	25.4	MNPT	1.50	38.1	FNPT	3.13	79.5	N/A	N/A	11.50	5.22	N/A	N/A
	1.00	25.4	FNPT	1.50	38.1	FNPT	3.13	79.5	N/A	N/A	11.50	5.22	N/A	N/A
19226H	1.00	25.4	FNPT	1.50	38.1	FNPT	4.63	117.6	N/A	N/A	30.00	13.61	N/A	N/A
19357L	1.50	38.1	FNPT	2.00	50.8	FNPT	3.63	92.2	N/A	N/A	18.00	8.16	N/A	N/A
19357M	1.50	38.1	FNPT	2.00	50.8	FNPT	4.63	117.6	N/A	N/A	30.00	13.61	N/A	N/A
19567L	2.00	50.8	FNPT	2.50	63.5	FNPT	3.63	92.2	N/A	N/A	19.00	8.62	N/A	N/A
	2.00	50.8	FNPT	2.50	63.5	FNPT	4.63	117.6	N/A	N/A	30.00	13.61	N/A	N/A

Note:

1. Valves are provided with a male pipe threaded (MNPT) or a female pipe threaded (FNPT) inlet connection.

Dimensions and Weights

Socket Weld Connections

19000 Socket Weld Connections

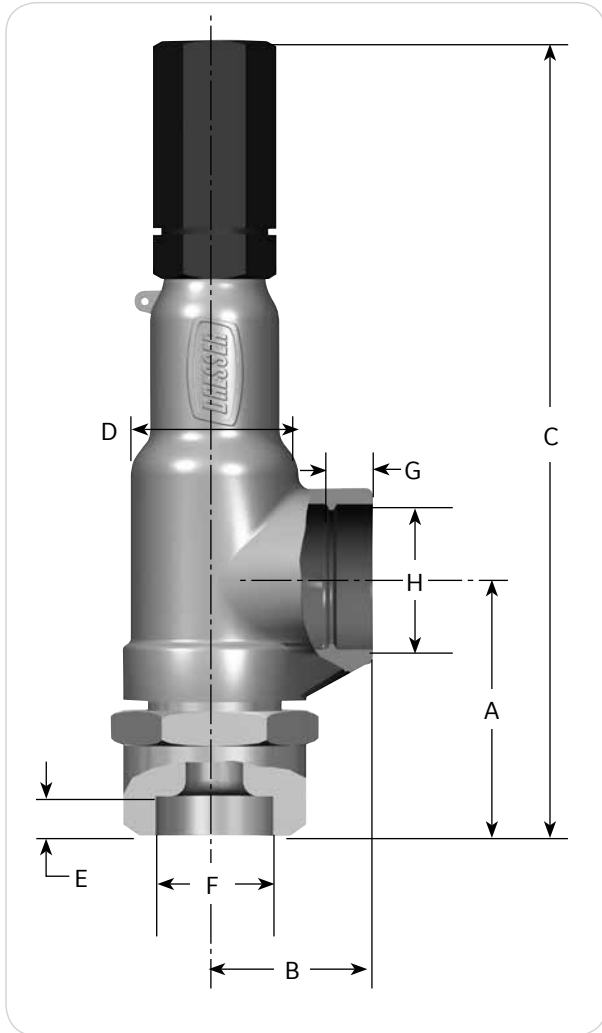

19000MBP Socket Weld Connections

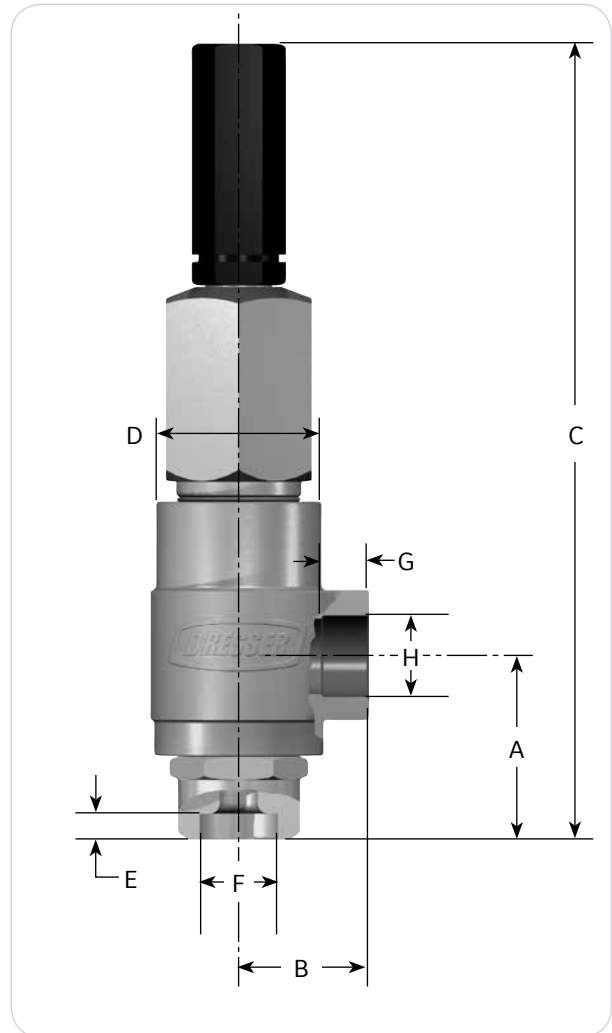

CAUTION

Avoid excessive weld deposits.

Dimensions and Weights

Socket Weld Connections

Socket Weld Connections (Standard & Backpressure Designs)																		
Valve Type	Inlet			Outlet			A		B		C				D			
	Size		Type	Size		Type					STD		MBP		STD		MBP	
	in	mm		in	mm		in	mm	in	mm	in	mm	in	mm	in	mm		
19096L	.50	12.7	SW	1.00	25.4	SW	3.50	88.9	1.88	47.8	10.63	270.0	N/A	N/A	2.00	50.8	N/A	N/A
	.75	19.1	SW	1.00	25.4	SW	3.50	88.9	1.88	47.8	10.63	270.0	N/A	N/A	2.00	50.8	N/A	N/A
	1.00	25.4	SW	1.00	25.4	SW	3.50	88.9	1.88	47.8	10.63	270.0	N/A	N/A	2.00	50.8	N/A	N/A
19096M	.50	12.7	SW	1.00	25.4	SW	3.50	88.9	2.00	50.8	12.44	316.0	13.13	333.4	2.56	65.0	3.75	95.3
	.75	19.1	SW	1.00	25.4	SW	3.50	88.9	2.00	50.8	12.44	316.0	13.13	333.4	2.56	65.0	3.75	95.3
	1.00	25.4	SW	1.00	25.4	SW	3.50	88.9	2.00	50.8	12.44	316.0	13.13	333.4	2.56	65.0	3.75	95.3
19096H	.75	19.1	SW	1.00	25.4	SW	4.00	101.6	2.38	60.5	13.38	339.9	N/A	N/A	3.13	79.5	N/A	N/A
19110L	.50	12.7	SW	1.00	25.4	SW	3.50	88.9	1.88	47.8	10.63	270.0	N/A	N/A	2.00	50.8	N/A	N/A
	.75	19.1	SW	1.00	25.4	SW	3.50	88.9	1.88	47.8	10.63	270.0	N/A	N/A	2.00	50.8	N/A	N/A
	1.00	25.4	SW	1.00	25.4	SW	3.50	88.9	1.88	47.8	10.63	270.0	N/A	N/A	2.00	50.8	N/A	N/A
19110M	.50	12.7	SW	1.00	25.4	SW	3.50	88.9	2.00	50.8	12.44	316.0	N/A	N/A	2.56	65.0	N/A	N/A
	.75	19.1	SW	1.00	25.4	SW	3.50	88.9	2.00	50.8	12.44	316.0	N/A	N/A	2.56	65.0	N/A	N/A
	1.00	25.4	SW	1.00	25.4	SW	3.50	88.9	2.00	50.8	12.44	316.0	N/A	N/A	2.56	65.0	N/A	N/A
19110H	.75	19.1	SW	1.00	25.4	SW	4.00	101.6	2.38	60.5	13.38	339.9	N/A	N/A	3.13	79.5	N/A	N/A
19126L	.75	19.1	SW	1.00	25.4	SW	3.50	88.9	1.88	47.8	10.63	270.0	N/A	N/A	2.00	50.8	N/A	N/A
	1.00	25.4	SW	1.00	25.4	SW	3.50	88.9	1.88	47.8	10.63	270.0	N/A	N/A	2.00	50.8	N/A	N/A
19126M	.75	19.1	SW	1.00	25.4	SW	3.50	88.9	2.00	50.8	12.44	316.0	N/A	N/A	2.56	65.0	N/A	N/A
	1.00	25.4	SW	1.00	25.4	SW	3.50	88.9	2.00	50.8	12.44	316.0	N/A	N/A	2.56	65.0	N/A	N/A
19126H	.75	19.1	SW	1.00	25.4	SW	4.50	114.3	3.13	79.5	17.31	439.7	N/A	N/A	4.63	117.6	N/A	N/A
19226L	1.00	25.4	SW	1.50	38.1	SW	3.94	100.1	2.25	57.2	11.94	303.3	N/A	N/A	2.38	60.5	N/A	N/A
19226M	1.00	25.4	SW	1.50	38.1	SW	3.94	100.1	2.38	60.5	13.31	338.1	N/A	N/A	3.13	79.5	N/A	N/A
19226H	1.00	25.4	SW	1.50	38.1	SW	4.50	114.3	3.13	79.5	17.31	439.7	N/A	N/A	4.63	117.6	N/A	N/A
19357L	1.50	38.1	SW	2.00	50.8	SW	4.75	120.7	3.13	79.5	15.75	400.1	N/A	N/A	3.63	92.2	N/A	N/A
19357M	1.50	38.1	SW	2.00	50.8	SW	4.75	120.7	3.13	79.5	17.56	446.0	N/A	N/A	4.63	117.6	N/A	N/A
19567L	2.00	50.8	SW	2.50	63.5	SW	5.38	136.7	3.13	79.5	16.38	416.1	N/A	N/A	3.63	92.2	N/A	N/A
19567M	2.00	50.8	SW	2.50	63.5	SW	5.38	136.7	3.13	79.5	18.19	462.0	N/A	N/A	4.63	117.6	N/A	N/A

Dimensions and Weights

Socket Weld Connections

Socket Weld Connections (Standard & Backpressure Designs)																		
Valve Type	Inlet			Outlet			E		F		G		H		Approx. Weight			
	Size		Type	Size		Type	in	mm	in	mm	in	mm	in	mm	STD		MBP	
	in	mm		in	mm										lb	kg	lb	kg
19096L	.50	12.7	SW	1.00	25.4	SW	.50	12.7	.86	21.7	.63	16.0	1.33	33.8	5.50	2.49	N/A	N/A
	.75	19.1	SW	1.00	25.4	SW	.50	12.7	1.07	27.1	.63	16.0	1.33	33.8	5.50	2.49	N/A	N/A
	1.00	25.4	SW	1.00	25.4	SW	.50	12.7	1.33	33.8	.63	16.0	1.33	33.8	6.25	2.83	N/A	N/A
19096M	.50	12.7	SW	1.00	25.4	SW	.50	12.7	.86	21.7	.63	16.0	1.33	33.8	7.00	3.18	12.00	5.44
	.75	19.1	SW	1.00	25.4	SW	.50	12.7	1.07	27.1	.63	16.0	1.33	33.8	7.50	3.40	12.50	5.67
	1.00	25.4	SW	1.00	25.4	SW	.50	12.7	1.33	33.8	.63	16.0	1.33	33.8	8.00	3.63	13.00	5.90
19096H	.75	19.1	SW	1.00	25.4	SW	.50	12.7	1.07	27.1	.63	16.0	1.33	33.8	12.00	5.44	N/A	N/A
19110L	.50	12.7	SW	1.00	25.4	SW	.50	12.7	.86	21.7	.63	16.0	1.33	33.8	5.50	2.49	N/A	N/A
	.75	19.1	SW	1.00	25.4	SW	.50	12.7	1.07	27.1	.63	16.0	1.33	33.8	5.50	2.49	N/A	N/A
	1.00	25.4	SW	1.00	25.4	SW	.50	12.7	1.33	33.8	.63	16.0	1.33	33.8	6.25	2.83	N/A	N/A
19110M	.50	12.7	SW	1.00	25.4	SW	.50	12.7	.86	21.7	.63	16.0	1.33	33.8	7.00	3.18	N/A	N/A
	.75	19.1	SW	1.00	25.4	SW	.50	12.7	1.07	27.1	.63	16.0	1.33	33.8	7.50	3.40	N/A	N/A
	1.00	25.4	SW	1.00	25.4	SW	.50	12.7	1.33	33.8	.63	16.0	1.33	33.8	8.00	3.63	N/A	N/A
19110H	.75	19.1	SW	1.00	25.4	SW	.50	12.7	1.07	27.1	.63	16.0	1.33	33.8	12.00	5.44	N/A	N/A
19126L	.75	19.1	SW	1.00	25.4	SW	.50	12.7	1.07	27.1	.63	16.0	1.33	33.8	6.00	2.72	N/A	N/A
	1.00	25.4	SW	1.00	25.4	SW	.50	12.7	1.33	33.8	.63	16.0	1.33	33.8	6.75	3.06	N/A	N/A
19126M	.75	19.1	SW	1.00	25.4	SW	.50	12.7	1.07	27.1	.63	16.0	1.33	33.8	7.00	3.18	N/A	N/A
	1.00	25.4	SW	1.00	25.4	SW	.50	12.7	1.33	33.8	.63	16.0	1.33	33.8	8.00	3.63	N/A	N/A
19126H	.75	19.1	SW	1.00	25.4	SW	.63	16.0	1.07	27.1	.63	16.0	1.33	33.8	32.00	14.51	N/A	N/A
19226L	1.00	25.4	SW	1.50	38.1	SW	.50	12.7	1.33	33.8	.63	16.0	1.92	48.6	8.00	3.63	N/A	N/A
19226M	1.00	25.4	SW	1.50	38.1	SW	.50	12.7	1.33	33.8	.63	16.0	1.92	48.6	12.50	5.67	N/A	N/A
19226H	1.00	25.4	SW	1.50	38.1	SW	.63	16.0	1.33	33.8	.63	16.0	1.92	48.6	32.00	14.51	N/A	N/A
19357L	1.50	38.1	SW	2.00	50.8	SW	.63	16.0	1.92	48.6	.63	16.0	2.41	61.1	18.25	8.28	N/A	N/A
19357M	1.50	38.1	SW	2.00	50.8	SW	.63	16.0	1.92	48.6	.63	16.0	2.41	61.1	31.00	14.06	N/A	N/A
19567L	2.00	50.8	SW	2.50	63.5	SW	.63	16.0	2.41	61.1	.63	16.0	2.91	73.8	24.00	10.89	N/A	N/A
19567M	2.00	50.8	SW	2.50	63.5	SW	.63	16.0	2.41	61.1	.63	16.0	2.91	73.8	34.00	15.42	N/A	N/A

Dimensions and Weights

Flanged Connections

19000 Flanged Connections

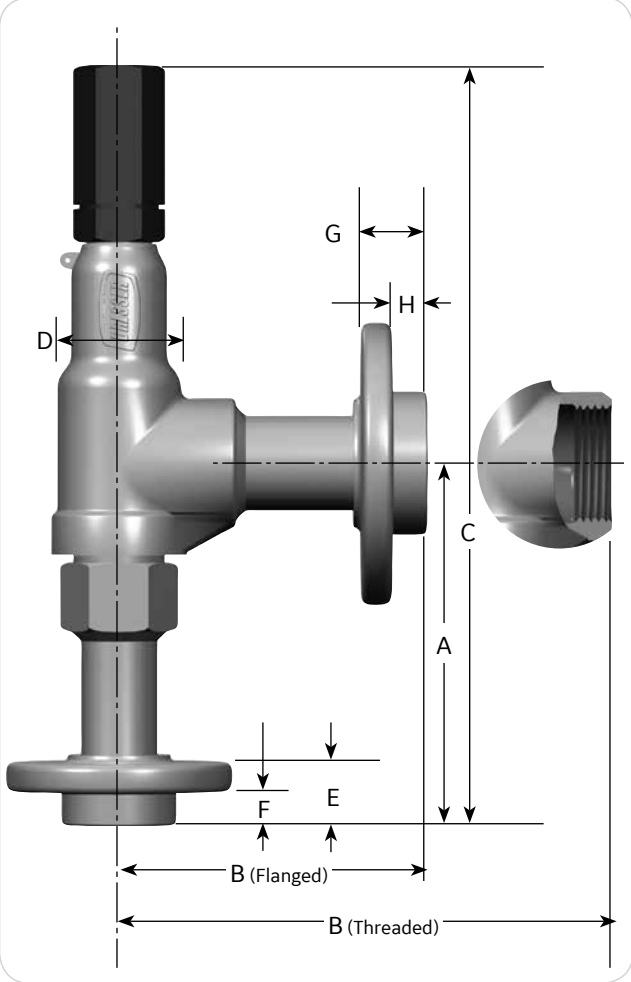

19000MBP Flanged Connections

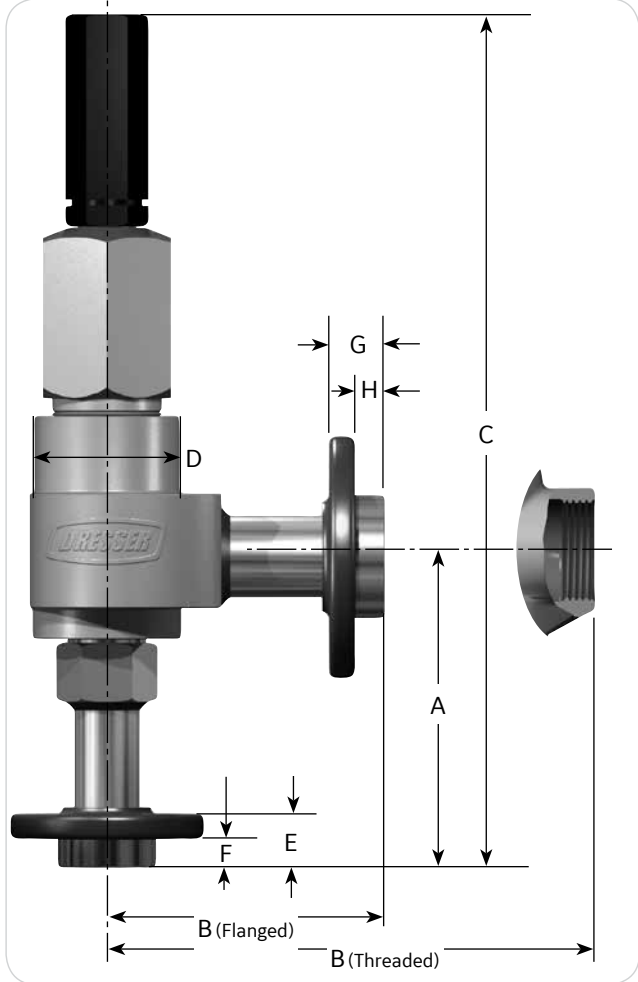

Dimensions and Weights

Flanged Connections

Flanged Connections (Standard Design)																
Valve Type	Inlet			Outlet			A		B		C		D		E	
	Size		Type	Size		Type	in.	mm	in.	mm	in.	mm	in.	mm	in.	mm
	in	mm		in	mm											
19096L 19110L	.50	12.7	150#	1.00	25.4	FNPT 150#	6.00	152.4	1.88	47.8	13.13	333.5	2.00	50.8	.88	22.4
	.50	12.7	300#	1.00	25.4	FNPT 150#	6.00	152.4	1.88	47.8	13.13	333.5	2.00	50.8	1.00	25.4
	.75	19.05	150#	1.00	25.4	FNPT 150#	6.25	158.8	7.88 4.88	200.2 124.0	13.38	339.9	2.00	50.8	1.00	25.4
	.75	19.05	300#	1.00	25.4	FNPT 150#	6.25	158.8	7.88 4.88	200.2 124.0	13.38	339.9	2.00	50.8	1.13	28.7
	1.00	25.4	150#	1.00	25.4	FNPT 150#	6.50	165.1	1.88 4.88	47.8 124.0	13.63	346.2	2.00	50.8	1.06	26.9
	1.00	25.4	300#	1.00	25.4	FNPT 150#	6.50	165.1	1.88 4.88	47.8 124.0	13.63	346.2	2.00	50.8	1.19	30.2
19126L	.75	19.05	150#	1.00	25.4	FNPT 150#	6.25	158.8	1.88 4.88	47.8 124.0	13.38	339.9	2.00	50.8	1.00	25.4
	.75	19.05	300#	1.00	25.4	FNPT 150#	6.25	158.8	1.88 4.88	47.8 124.0	13.38	339.9	2.00	50.8	1.13	28.7
	1.00	25.4	150#	1.00	25.4	FNPT 150#	6.50	165.1	1.88 4.88	47.8 124.0	13.63	346.2	2.00	50.8	1.06	26.9
	1.00	25.4	300#	1.00	25.4	FNPT 150#	6.50	165.1	1.88 4.88	47.8 124.0	13.63	346.2	2.00	50.8	1.19	30.2
19226L	1.00	25.4	150#	1.50	38.1	FNPT 150#	6.25	158.8	2.25 6.13	57.2 155.7	14.25	362.0	2.38	60.5	1.06	26.9
	1.00	25.4	300#	1.50	38.1	FNPT 150#	6.25	158.8	2.25 6.13	57.2 155.7	14.25	362.0	2.38	60.5	1.19	30.2
19357L	1.50	38.1	150#	2.00	50.8	FNPT 150#	7.13	181.1	3.13 6.13	79.5 155.7	18.13	460.5	3.63	92.2	1.19	30.2
	1.50	38.1	300#	2.00	50.8	FNPT 150#	7.13	181.1	3.13 6.13	79.5 155.7	18.13	460.5	3.63	92.2	1.31	33.3
19567L	2.00	50.8	150#	2.50	63.5	FNPT 150#	7.13	181.1	3.13 6.13	79.5 155.7	18.13	460.5	3.63	92.2	1.38	35.1
	2.00	50.8	300#	2.50	63.5	FNPT 150#	7.13	181.1	3.13 6.13	79.5 155.7	18.13	460.5	3.63	92.2	1.50	38.1

Dimensions and Weights

Flanged Connections

Flanged Connections (Standard Design)														
Valve Type	Inlet			Outlet			F		G		H		Approx. Weight	
	Size		Type	Size		Type	in.	mm	in.	mm	in.	mm	lb	kg
	in.	mm		in.	mm									
19096L 19110L	.50	12.7	150#	1.00	25.4	FNPT	.44	11.1	1.06	26.9	.50	12.7	6.30	2.86
						150#							9.30	4.22
	.50	12.7	300#	1.00	25.4	FNPT	.44	11.1	1.06	26.9	.50	12.7	7.30	3.31
						150#							10.30	4.67
	.75	19.05	150#	1.00	25.4	FNPT	.50	12.7	1.06	26.9	.50	12.7	7.00	3.18
						150#							10.00	4.54
.75	19.05	300#	1.00	25.4	FNPT	.50	12.7	1.06	26.9	.50	12.7	8.50	3.86	
					150#							11.50	5.22	
1.00	25.4	150#	1.00	25.4	FNPT	.50	12.7	1.06	26.9	.50	12.7	7.80	3.54	
					150#							10.80	4.90	
1.00	25.4	300#	1.00	25.4	FNPT	.50	12.7	1.06	26.9	.50	12.7	9.30	4.22	
					150#							12.30	5.58	
19126L	.75	19.05	150#	1.00	25.4	FNPT	.50	12.7	1.06	26.9	.50	12.7	7.50	3.40
						150#							10.30	4.67
	.75	19.05	300#	1.00	25.4	FNPT	.50	12.7	1.06	26.9	.50	12.7	9.00	4.08
						150#							12.00	5.44
1.00	25.4	150#	1.00	25.4	FNPT	.50	12.7	1.06	26.9	.50	12.7	8.30	3.76	
					150#							11.30	5.13	
1.00	25.4	300#	1.00	25.4	FNPT	.50	12.7	1.06	26.9	.50	12.7	9.80	4.45	
					150#							12.80	5.81	
19226L	1.00	25.4	150#	1.50	38.1	FNPT	.50	12.7	1.19	30.2	.50	12.7	9.80	4.45
						150#							14.80	6.71
	1.00	25.4	300#	1.50	38.1	FNPT	.50	12.7	1.19	30.2	.50	12.7	11.30	5.13
						150#							16.30	7.39
19357L	1.50	38.1	150#	2.00	50.8	FNPT	.50	12.7	1.38	35.1	.63	16.0	22.80	10.34
						150#							30.30	13.74
	1.50	38.1	300#	2.00	50.8	FNPT	.50	12.7	1.38	35.1	.63	16.0	26.30	11.93
						150#							33.80	15.33
19567L	2.00	50.8	150#	2.50	63.5	FNPT	.63	15.9	1.50	38.1	.63	16.0	26.80	12.16
						150#							38.30	17.37
	2.00	50.8	300#	2.50	63.5	FNPT	.63	15.9	1.50	38.1	.63	16.0	28.80	13.06
						150#							40.30	18.28

Dimensions and Weights

Flanged Connections

Flanged Connections (Standard Design)																
Valve Type	Inlet			Outlet			A		B		C		D		E	
	Size		Type	Size		Type	in.	mm	in.	mm	in.	mm	in.	mm	in.	mm
	in	mm		in	mm											
19096M 19110M	.50	12.7	300#	1.00	25.4	FNPT	6.00	152.4	2.00	50.8	14.94	379.5	2.56	65.0	1.00	25.4
						150#			4.88	124.0						
	.50	12.7	600#	1.00	25.4	FNPT	6.00	152.4	2.00	50.8	14.94	379.5	2.56	65.0	1.00	25.4
						150#			4.88	124.0						
	.50	12.7	900#	1.00	25.4	FNPT	6.50	165.1	2.00	50.8	15.44	392.2	2.56	65.0	1.50	38.1
						300#			4.88	124.0						
	.50	12.7	1500#	1.00	25.4	FNPT	6.50	165.1	2.00	50.8	15.44	392.2	2.56	65.0	1.50	38.1
						300#			4.88	124.0						
	.75	19.1	300#	1.00	25.4	FNPT	6.25	158.75	2.00	50.8	15.19	385.8	2.56	65.0	1.13	28.7
						150#			4.88	124.0						
	.75	19.1	600#	1.00	25.4	FNPT	6.25	158.75	2.00	50.8	15.19	385.8	2.56	65.0	1.13	28.7
						150#			4.88	124.0						
.75	19.1	900#	1.00	25.4	FNPT	6.75	171.45	2.00	50.8	15.69	398.5	2.56	65.0	1.63	41.4	
					300#			4.88	124.0							
.75	19.1	1500#	1.00	25.4	FNPT	6.75	171.45	2.00	50.8	15.69	398.5	2.56	65.0	1.63	41.4	
					300#			4.88	124.0							
1.00	25.4	300#	1.00	25.4	FNPT	6.50	165.1	2.00	50.8	15.44	392.2	2.56	65.0	1.19	30.2	
					150#			4.88	124.0							
1.00	25.4	600#	1.00	25.4	FNPT	6.50	165.1	2.00	50.8	15.44	392.2	2.56	65.0	1.19	30.2	
					150#			4.88	124.0							
1.00	25.4	900#	1.00	25.4	FNPT	7.50	190.5	2.00	50.8	16.44	417.6	2.56	65.0	1.75	44.5	
					300#			4.88	124.0							
1.00	25.4	1500#	1.00	25.4	FNPT	7.50	190.5	2.00	50.8	16.44	417.6	2.56	65.0	1.75	44.5	
					300#			4.88	124.0							
19126M	.75	19.1	300#	1.00	25.4	FNPT	6.25	158.75	2.00	50.8	15.19	385.8	2.56	65.0	1.13	28.7
						150#			4.88	124.0						
	.75	19.1	600#	1.00	25.4	FNPT	6.25	158.75	2.00	50.8	15.19	385.8	2.56	65.0	1.13	28.7
						150#			4.88	124.0						
	.75	19.1	900#	1.00	25.4	FNPT	6.75	171.45	2.00	50.8	15.69	398.5	2.56	65.0	1.63	41.4
						300#			4.88	124.0						
	.75	19.1	1500#	1.00	25.4	FNPT	6.75	171.45	2.00	50.8	15.69	398.5	2.56	65.0	1.63	41.4
						300#			4.88	124.0						
1.00	25.4	300#	1.00	25.4	FNPT	6.50	165.1	2.00	50.8	15.44	392.2	2.56	65.0	1.19	30.2	
					150#			4.88	124.0							
1.00	25.4	600#	1.00	25.4	FNPT	6.50	165.1	2.00	50.8	15.44	392.2	2.56	65.0	1.19	30.2	
					150#			4.88	124.0							
1.00	25.4	900#	1.00	25.4	FNPT	7.50	190.5	2.00	50.8	16.44	417.6	2.56	65.0	1.75	44.5	
					300#			4.88	124.0							
1.00	25.4	1500#	1.00	25.4	FNPT	7.50	190.5	2.00	50.8	16.44	417.6	2.56	65.0	1.75	44.5	
					300#			4.88	124.0							

Dimensions and Weights

Flanged Connections

Flanged Connections (Standard Design)														
Valve Type	Inlet			Outlet			F		G		H		Approx. Weight	
	Size		Type	Size		Type	in	mm	in	mm	in	mm	lb	kg
	in	mm		in	mm									
19096M 19110M	.50	12.7	300#	1.00	25.4	FNPT	.44	11.1	1.06	26.9	.50	12.7	9.00	4.08
						150#							12.00	5.44
	.50	12.7	600#	1.00	25.4	FNPT	.44	11.1	1.06	26.9	.50	12.7	9.00	4.08
						150#							12.00	5.44
	.50	12.7	900#	1.00	25.4	FNPT	.63	15.9	1.19	30.2	.50	12.7	13.30	6.03
						300#							17.80	8.07
	.50	12.7	1500#	1.00	25.4	FNPT	.63	15.9	1.19	30.2	.50	12.7	13.30	6.03
						300#							17.80	8.07
	.75	19.1	300#	1.00	25.4	FNPT	.50	12.7	1.06	26.9	.50	12.7	10.30	4.67
						150#							13.30	6.03
	.75	19.1	600#	1.00	25.4	FNPT	.50	12.7	1.06	26.9	.50	12.7	10.30	4.67
						150#							13.30	6.03
.75	19.1	900#	1.00	25.4	FNPT	.63	15.9	1.19	30.2	.50	12.7	13.50	6.12	
					300#							18.00	8.16	
.75	19.1	1500#	1.00	25.4	FNPT	.63	15.9	1.19	30.2	.50	12.7	13.50	6.12	
					300#							18.00	8.16	
1.00	25.4	300#	1.00	25.4	FNPT	.50	12.7	1.06	26.9	.50	12.7	11.00	4.99	
					150#							14.00	6.35	
1.00	25.4	600#	1.00	25.4	FNPT	.50	12.7	1.06	26.9	.50	12.7	11.00	4.99	
					150#							14.00	6.35	
1.00	25.4	900#	1.00	25.4	FNPT	.63	15.9	1.19	30.2	.50	12.7	15.50	7.03	
					300#							20.00	9.07	
1.00	25.4	1500#	1.00	25.4	FNPT	.63	15.9	1.19	30.2	.50	12.7	15.50	7.03	
					300#							20.00	9.07	
19126M	.75	19.1	300#	1.00	25.4	FNPT	.50	12.7	1.06	26.9	.50	12.7	10.30	4.67
						150#							13.30	6.03
	.75	19.1	600#	1.00	25.4	FNPT	.50	12.7	1.06	26.9	.50	12.7	10.30	4.67
						150#							13.30	6.03
	.75	19.1	900#	1.00	25.4	FNPT	.63	15.9	1.19	30.2	.50	12.7	13.50	6.12
						300#							18.00	8.16
	.75	19.1	1500#	1.00	25.4	FNPT	.63	15.9	1.19	30.2	.50	12.7	13.50	6.12
						300#							18.00	8.16
1.00	25.4	300#	1.00	25.4	FNPT	.50	12.7	1.06	26.9	.50	12.7	11.00	4.99	
					150#							14.00	6.35	
1.00	25.4	600#	1.00	25.4	FNPT	.50	12.7	1.06	26.9	.50	12.7	11.00	4.99	
					150#							14.00	6.35	
1.00	25.4	900#	1.00	25.4	FNPT	.63	15.9	1.19	30.2	.50	12.7	15.80	7.17	
					300#							20.30	9.21	
1.00	25.4	1500#	1.00	25.4	FNPT	.63	15.9	1.19	30.2	.50	12.7	15.80	7.17	
					300#							20.30	9.21	

Dimensions and Weights

Flanged Connections

Flanged Connections (Standard Design)																
Valve Type	Inlet			Outlet			A		B		C		D		E	
	Size		Type	Size		Type	in.	mm	in.	mm	in.	mm	in.	mm	in.	mm
	in.	mm		in.	mm											
19226M	1.00	25.4	300#	1.50	38.1	FNPT	6.25	158.8	2.38	60.5	15.63	397.0	3.13	79.5	1.19	30.2
						150#			6.13	155.7						
	1.00	25.4	600#	1.50	38.1	FNPT	6.25	158.8	2.38	60.5	15.63	397.0	3.13	79.5	1.19	30.2
						150#			6.13	155.7						
1.00	25.4	900#	1.50	38.1	FNPT	7.25	184.2	2.38	60.5	16.63	422.4	3.13	79.5	1.75	44.5	
					300#			6.13	155.7							
1.00	25.4	1500#	1.50	38.1	FNPT	7.25	184.2	2.38	60.5	16.63	422.4	3.13	79.5	1.75	44.5	
					300#			6.13	155.7							
19357M	1.50	38.1	300#	2.00	50.8	FNPT	7.13	181.1	3.13	79.5	19.94	506.5	4.63	117.6	1.31	33.3
						150#			6.13	155.7						
	1.50	38.1	600#	2.00	50.8	FNPT	7.13	181.1	3.13	79.5	19.94	506.5	4.63	117.6	1.38	35.1
						150#			6.13	155.7						
1.50	38.1	900#	2.00	50.8	FNPT	8.25	209.6	3.13	79.5	21.06	534.9	4.63	117.6	1.88	47.8	
					300#			6.13	155.7							
1.50	38.1	1500#	2.00	50.8	FNPT	8.25	209.6	3.13	79.5	21.06	534.9	4.63	117.6	1.88	47.8	
					300#			6.13	155.7							
19567M	2.00	50.8	300#	2.50	63.5	FNPT	7.13	181.1	3.13	79.5	19.94	506.5	4.63	117.6	1.50	38.1
						150#			6.13	155.7						
	2.00	50.8	600#	2.50	63.5	FNPT	7.13	181.1	3.13	79.5	19.94	506.5	4.63	117.6	1.63	41.4
						150#			6.13	155.7						
2.00	50.8	900#	2.50	63.5	FNPT	8.25	209.6	3.13	79.5	21.06	534.9	4.63	117.6	2.13	54.1	
					300#			6.13	155.7							
2.00	50.8	1500#	2.50	63.5	FNPT	8.25	209.6	3.13	79.5	21.06	534.9	4.63	117.6	2.13	54.1	
					300#			6.13	155.7							

Dimensions and Weights

Flanged Connections

Flanged Connections (Standard Design)															
Valve Type	Inlet			Outlet			F		G		H		Approx. Weight		
	Size		Type	Size		Type	in.	mm	in.	mm	in.	mm	lb	kg	
	in.	mm		in.	mm										
19226M	1.00	25.4	300#	1.50	38.1	FNPT	.50	12.7	1.19	30.2	.50	12.7	16.00	7.26	
						150#	.50	12.7	1.19	30.2	.50	12.7	21.00	9.53	
	1.00	25.4	600#	1.50	38.1	FNPT	.50	12.7	1.19	30.2	.50	12.7	16.00	7.26	
						150#	.50	12.7	1.19	30.2	.50	12.7	21.00	9.53	
	1.00	25.4	900#	1.50	38.1	FNPT	.63	15.9	1.31	33.3	.50	12.7	20.50	9.30	
						300#	.63	15.9	1.31	33.3	.50	12.7	29.00	13.15	
	1.00	25.4	1500#	1.50	38.1	FNPT	.63	15.9	1.31	33.3	.50	12.7	20.50	9.30	
						300#	.63	15.9	1.31	33.3	.50	12.7	29.00	13.15	
	19357M	1.50	38.1	300#	2.00	50.8	FNPT	.50	12.7	1.38	35.1	.63	15.9	38.30	17.37
							150#	.50	12.7	1.38	35.1	.63	15.9	45.80	20.77
1.50		38.1	600#	2.00	50.8	FNPT	.50	12.7	1.38	35.1	.63	15.9	38.30	17.37	
						150#	.50	12.7	1.38	35.1	.63	15.9	45.80	20.77	
1.50		38.1	900#	2.00	50.8	FNPT	.63	15.9	1.50	38.1	.63	15.9	46.80	21.23	
						300#	.63	15.9	1.50	38.1	.63	15.9	56.30	25.54	
1.50		38.1	1500#	2.00	50.8	FNPT	.63	15.9	1.50	38.1	.63	15.9	46.80	21.23	
						300#	.63	15.9	1.50	38.1	.63	15.9	56.30	25.54	
19567M		2.00	50.8	300#	2.50	63.5	FNPT	.63	15.9	1.50	38.1	.63	15.9	39.80	18.05
							150#	.63	15.9	1.50	38.1	.63	15.9	51.30	23.27
	2.00	50.8	600#	2.50	63.5	FNPT	.63	15.9	1.50	38.1	.63	15.9	40.80	18.51	
						150#	.63	15.9	1.50	38.1	.63	15.9	52.30	23.72	
	2.00	50.8	900#	2.50	63.5	FNPT	.63	15.9	1.63	41.4	.63	15.9	55.30	25.08	
						300#	.63	15.9	1.63	41.4	.63	15.9	68.80	31.21	
	2.00	50.8	1500#	2.50	63.5	FNPT	.63	15.9	1.63	41.4	.63	15.9	55.30	25.08	
						300#	.63	15.9	1.63	41.4	.63	15.9	68.80	31.21	

Dimensions and Weights

Flanged Connections

Flanged Connections (Standard Design)																
Valve Type	Inlet			Outlet			A		B		C		D		E	
	Size		Type	Size		Type	in.	mm	in.	mm	in.	mm	in.	mm	in.	mm
	in.	mm		in.	mm											
19096H 19110H	.75	19.1	1500#	1.00	25.4	FNPT	6.50	165.1	2.38	60.5	15.63	397.0	3.13	79.5	1.63	41.4
						300#	6.50	165.1	6.25	158.8	15.63	397.0	3.13	79.5		
	.75	19.1	2500#	1.00	25.4	FNPT	6.50	165.1	2.38	60.5	15.63	397.0	3.13	79.5	1.88	47.8
						300#	6.50	165.1	6.25	158.8	15.63	397.0	3.13	79.5		
19126H	.75	19.1	1500#	1.00	25.4	FNPT	6.50	165.1	3.13	79.5	19.06	484.1	4.63	117.6	1.63	41.4
						300#	6.50	165.1	6.25	158.8	19.06	484.1	4.63	117.6		
	.75	19.1	2500#	1.00	25.4	FNPT	6.50	165.1	3.13	79.5	19.06	484.1	4.63	117.6	1.88	47.8
						300#	6.50	165.1	6.25	158.8	19.06	484.1	4.63	117.6		
19226H	1.00	25.4	1500#	1.50	38.1	FNPT	7.25	184.15	3.13	79.5	16.38	416.1	4.63	117.6	1.75	44.5
						300#	7.25	184.15	6.13	155.7	16.38	416.1	4.63	117.6		
	1.00	25.4	2500#	1.50	38.1	FNPT	7.25	184.15	3.13	79.5	16.38	416.1	4.63	117.6	2.00	50.8
						300#	7.25	184.15	6.13	155.7	16.38	416.1	4.63	117.6		

Flanged Connections (Standard Design)														
Valve Type	Inlet			Outlet			F		G		H		Approx. Weight	
	Size		Type	Size		Type	in.	mm	in.	mm	in.	mm	lb	kg
	in.	mm		in.	mm									
19096H 19110H	.75	19.1	1500#	1.00	25.4	FNPT	.63	15.9	1.19	30.2	.50	12.7	18.50	8.39
						300#							23.00	10.43
	.75	19.1	2500#	1.00	25.4	FNPT	.63	15.9	1.19	30.2	.50	12.7	20.80	9.43
						300#							25.30	11.48
19126H	.75	19.1	1500#	1.00	25.4	FNPT	.63	15.9	1.19	30.2	.50	12.7	37.00	16.78
						300#							41.50	18.82
	.75	19.1	2500#	1.00	25.4	FNPT	.63	15.9	1.19	30.2	.50	12.7	39.00	17.69
						300#							43.50	19.73
19226H	1.00	25.4	1500#	1.50	38.1	FNPT	.63	15.9	1.31	33.3	.50	12.7	39.00	17.69
						300#							47.00	21.32
	1.00	25.4	2500#	1.50	38.1	FNPT	.63	15.9	1.31	33.3	.50	12.7	43.50	19.73
						300#							51.50	23.36

Dimensions and Weights

Flanged Connections

Flanged Connections (Backpressure Design)																
Valve Type	Inlet			Outlet			A		B		C		D		E	
	Size		Type	Size		Type	in	mm	in	mm	in	mm	in	mm	in	mm
	in.	mm		in.	mm											
19096M	.50	12.7	150#	1.00	25.4	FNPT	6.00	152.4	2.00	50.8	15.63	397.0	3.75	95.3	.88	22.4
						150#										
	.50	12.7	300#	1.00	25.4	FNPT	6.00	152.4	2.00	50.8	15.63	397.0	3.75	95.3	1.00	25.4
						150#										
	.50	12.7	600#	1.00	25.4	FNPT	6.00	152.4	2.00	50.8	15.63	397.0	3.75	95.3	1.00	25.4
						150#										
	.50	12.7	900#	1.00	25.4	FNPT	6.50	165.1	2.00	50.8	16.13	409.7	3.75	95.3	1.50	38.1
						300#										
	.50	12.7	1500#	1.00	25.4	FNPT	6.50	165.1	2.00	50.8	16.13	409.7	3.75	95.3	1.50	38.1
						300#										
	.75	19.1	150#	1.00	25.4	FNPT	6.25	158.75	2.00	50.8	15.88	403.4	3.75	95.3	1.00	25.4
						150#										
	.75	19.1	300#	1.00	25.4	FNPT	6.25	158.75	2.00	50.8	15.88	403.4	3.75	95.3	1.13	28.7
						150#										
	.75	19.1	600#	1.00	25.4	FNPT	6.25	158.75	2.00	50.8	15.88	403.4	3.75	95.3	1.13	28.7
						150#										
.75	19.1	900#	1.00	25.4	FNPT	6.75	171.45	2.00	50.8	16.38	416.1	3.75	95.3	1.63	41.4	
					300#											
.75	19.1	1500#	1.00	25.4	FNPT	6.75	171.45	2.00	50.8	16.38	416.1	3.75	95.3	1.63	41.4	
					300#											
1.00	25.4	150#	1.00	25.4	FNPT	6.50	165.1	2.00	50.8	16.13	409.7	3.75	95.3	1.06	26.9	
					150#											
1.00	25.4	300#	1.00	25.4	FNPT	6.50	165.1	2.00	50.8	16.13	409.7	3.75	95.3	1.19	30.2	
					150#											
1.00	25.4	600#	1.00	25.4	FNPT	6.50	165.1	2.00	50.8	16.13	409.7	3.75	95.3	1.19	30.2	
					150#											
1.00	25.4	900#	1.00	25.4	FNPT	7.50	190.5	2.00	50.8	17.13	435.1	3.75	95.3	1.75	44.5	
					300#											
1.00	25.4	1500#	1.00	25.4	FNPT	7.50	190.5	2.00	50.8	17.13	435.1	3.75	95.3	1.75	44.5	
					300#											

Dimensions and Weights

Flanged Connections

Flanged Connections (Backpressure Design)														
Valve Type	Inlet			Outlet			F		G		H		Approx. Weight	
	Size		Type	Size		Type	in.	mm	in.	mm	in.	mm	lb.	kg
	in.	mm		in.	mm									
19096M	.50	12.7	150#	1.00	25.4	FNPT	.438	11.1	1.06	26.9	.50	12.7	13.00	5.9
						150#							16.00	7.3
	.50	12.7	300#	1.00	25.4	FNPT	.438	11.1	1.06	26.9	.50	12.7	14.00	6.4
						150#							17.00	7.7
	.50	12.7	600#	1.00	25.4	FNPT	.438	11.1	1.06	26.9	.50	12.7	14.00	6.4
						150#							17.00	7.7
	.50	12.7	900#	1.00	25.4	FNPT	.625	15.9	1.19	30.2	.50	12.7	18.25	8.3
						300#							22.75	10.3
	.50	12.7	1500#	1.00	25.4	FNPT	.625	15.9	1.19	30.2	.50	12.7	18.25	8.3
						300#							22.75	10.3
	.75	19.1	150#	1.00	25.4	FNPT	.500	12.7	1.06	26.9	.50	12.7	13.75	6.2
						150#							16.75	7.6
	.75	19.1	300#	1.00	25.4	FNPT	.500	12.7	1.06	26.9	.50	12.7	15.25	6.9
						150#							18.25	8.3
	.75	19.1	600#	1.00	25.4	FNPT	.500	12.7	1.06	26.9	.50	12.7	15.25	6.9
						150#							18.25	8.3
	.75	19.1	900#	1.00	25.4	FNPT	.625	15.9	1.19	30.2	.50	12.7	20.00	9.1
						300#							23.00	10.4
.75	19.1	1500#	1.00	25.4	FNPT	.625	15.9	1.19	30.2	.50	12.7	20.00	9.1	
					300#							23.00	10.4	
1.00	25.4	150#	1.00	25.4	FNPT	.500	12.7	1.06	26.9	.50	12.7	14.50	6.6	
					150#							17.50	7.9	
1.00	25.4	300#	1.00	25.4	FNPT	.500	12.7	1.06	26.9	.50	12.7	16.00	7.3	
					150#							19.00	8.6	
1.00	25.4	600#	1.00	25.4	FNPT	.500	12.7	1.06	26.9	.50	12.7	16.00	7.3	
					150#							19.00	8.6	
1.00	25.4	900#	1.00	25.4	FNPT	.625	15.9	1.19	30.2	.50	12.7	22.00	10.0	
					300#							25.00	11.3	
1.00	25.4	1500#	1.00	25.4	FNPT	.625	15.9	1.19	30.2	.50	12.7	22.00	10.0	
					300#							25.00	11.3	

Pressure/Temperature

General Information

19000 & 19096MBP Series

These ratings apply to threaded or socket weld end connections.

When the valves are supplied with flanged connections the flange ratings may govern the range of valve pressure/temperature rating.

Note: When soft seats are used, Elastomer material may govern the valve pressure/temperature rating.

When selecting valves for back pressure applications the following limits apply:

- Constant back pressure - 400 psig (27.58 barg).
- Variable back pressure (superimposed or built-up) - 400 psig (27.58 barg) or 10 percent of set pressure whichever is smaller.

Valves with set pressures less than 15 psig (1.03 barg) cannot be stamped with the ASME Code stamp.

19000 & 19096MBP Series

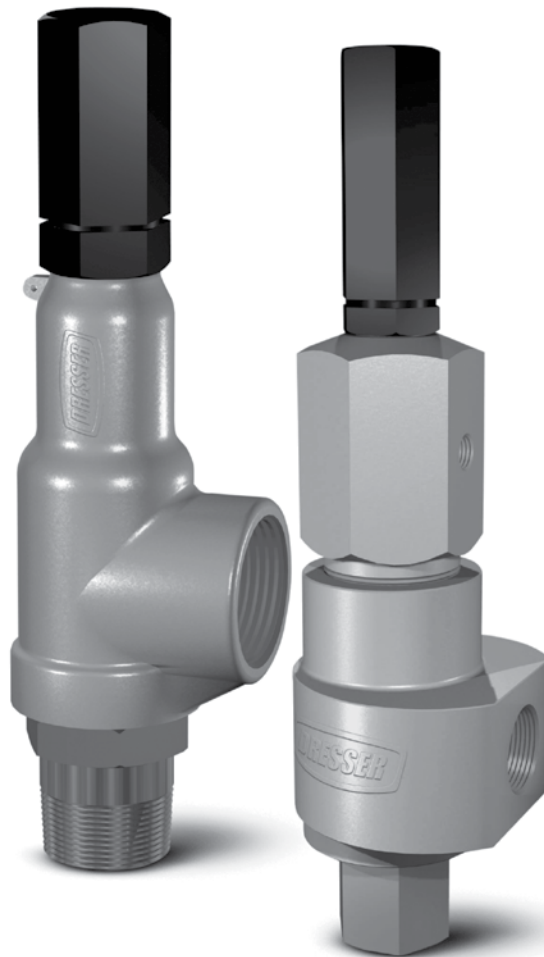

Pressure/Temperature

Pressure Temperature Ratings of 19000 Series Valves												
Valve Type	-425 °F (-253.9 °C)		-75 °F (-59.4 °C)		100 °F (37.8 °C)		200 °F (93.3 °C)		300 °F (148.9 °C)		400 °F (204.4 °C)	
	psig	barg	psig	barg	psig	barg	psig	barg	psig	barg	psig	barg
19096L	290	19.99	290	19.99	290	19.99	290	19.99	290	19.99	290	19.99
19110L	290	19.99	290	19.99	290	19.99	290	19.99	290	19.99	290	19.99
19126L	290	19.99	290	19.99	290	19.99	290	19.99	290	19.99	290	19.99
19226L	290	19.99	290	19.99	290	19.99	290	19.99	290	19.99	290	19.99
19357L	290	19.99	290	19.99	290	19.99	290	19.99	290	19.99	290	19.99
19567L	290	19.99	290	19.99	290	19.99	290	19.99	290	19.99	290	19.99
19096M	2000	137.89	2000	137.89	2000	137.89	2000	137.89	2000	137.89	2000	137.89
19110M	2000	137.89	2000	137.89	2000	137.89	2000	137.89	2000	137.89	2000	137.89
19126M	2000	137.89	2000	137.89	2000	137.89	2000	137.89	2000	137.89	2000	137.89
19226M	2000	137.89	2000	137.89	2000	137.89	2000	137.89	2000	137.89	2000	137.89
19357M	1500	103.42	1500	103.42	1500	103.42	1420	97.90	1340	92.38	1260	86.87
19567M	1000	68.94	1000	68.94	1000	68.94	960	66.18	920	63.43	880	60.67
19096H	5000	344.73	5000	344.73	5000	344.73	4811	331.70	4621	318.60	4432	305.57
19110H	5000	344.73	5000	344.73	5000	344.73	4811	331.70	4621	318.60	4432	305.57
19126H	8000	551.58	8000	551.58	8000	551.58	7785	536.75	7571	522.00	7357	507.24
19226H	6400	441.26	6400	441.26	6400	441.26	6107	421.06	5814	400.86	5521	380.65

Pressure Temperature Ratings of 19000 Series Valves														
Valve Type	500 °F (260.°C)		600 °F (315.6 °C)		700 °F (371.1 °C)		800 °F (426.7 °C)		900 °F (482.2 °C)		1000 °F (537.8 °C)		1100 °F (593.3 °C)	
	psig	barg	psig	barg	psig	barg	psig	barg	psig	barg	psig	barg	psig	barg
19096L	290	19.99	290	19.99	290	19.99	290	19.99	290	19.99	290	19.99	290	19.99
19110L	290	19.99	290	19.99	290	19.99	290	19.99	290	19.99	290	19.99	290	19.99
19126L	290	19.99	290	19.99	290	19.99	290	19.99	290	19.99	290	19.99	290	19.99
19226L	290	19.99	290	19.99	290	19.99	290	19.99	290	19.99	290	19.99	290	19.99
19357L	290	19.99	290	19.99	290	19.99	290	19.99	290	19.99	290	19.99	290	19.99
19567L	290	19.99	290	19.99	290	19.99	290	19.99	290	19.99	290	19.99	290	19.99
19096M	2000	137.89	2000	137.89	2000	137.89	2000	137.89	2000	137.89	2000	137.89	2000	137.89
19110M	2000	137.89	2000	137.89	2000	137.89	2000	137.89	2000	137.89	2000	137.89	2000	137.89
19126M	2000	137.89	2000	137.89	2000	137.89	2000	137.89	2000	137.89	2000	137.89	2000	137.89
19226M	2000	137.89	2000	137.89	2000	137.89	2000	137.89	2000	137.89	2000	137.89	2000	137.89
19357M	1180	81.35	1100	75.84	1020	70.32	940	64.81	860	59.29	780	53.77	700	48.26
19567M	840	57.91	800	55.15	760	52.40	720	49.64	680	46.88	640	44.12	600	41.36
19096H	4243	292.54	4054	279.51	3864	266.41	3675	253.38	-	-	-	-	-	-
19110H	4243	292.54	4054	279.51	3864	266.41	3675	253.38	-	-	-	-	-	-
19126H	7142	492.42	6928	477.66	6714	462.91	6500	448.15	-	-	-	-	-	-
19226H	5228	360.45	4935	340.25	4642	320.05	4350	299.92	-	-	-	-	-	-

Pressure/Temperature

Pressure / Temperature Rating of 19000 Series Valves

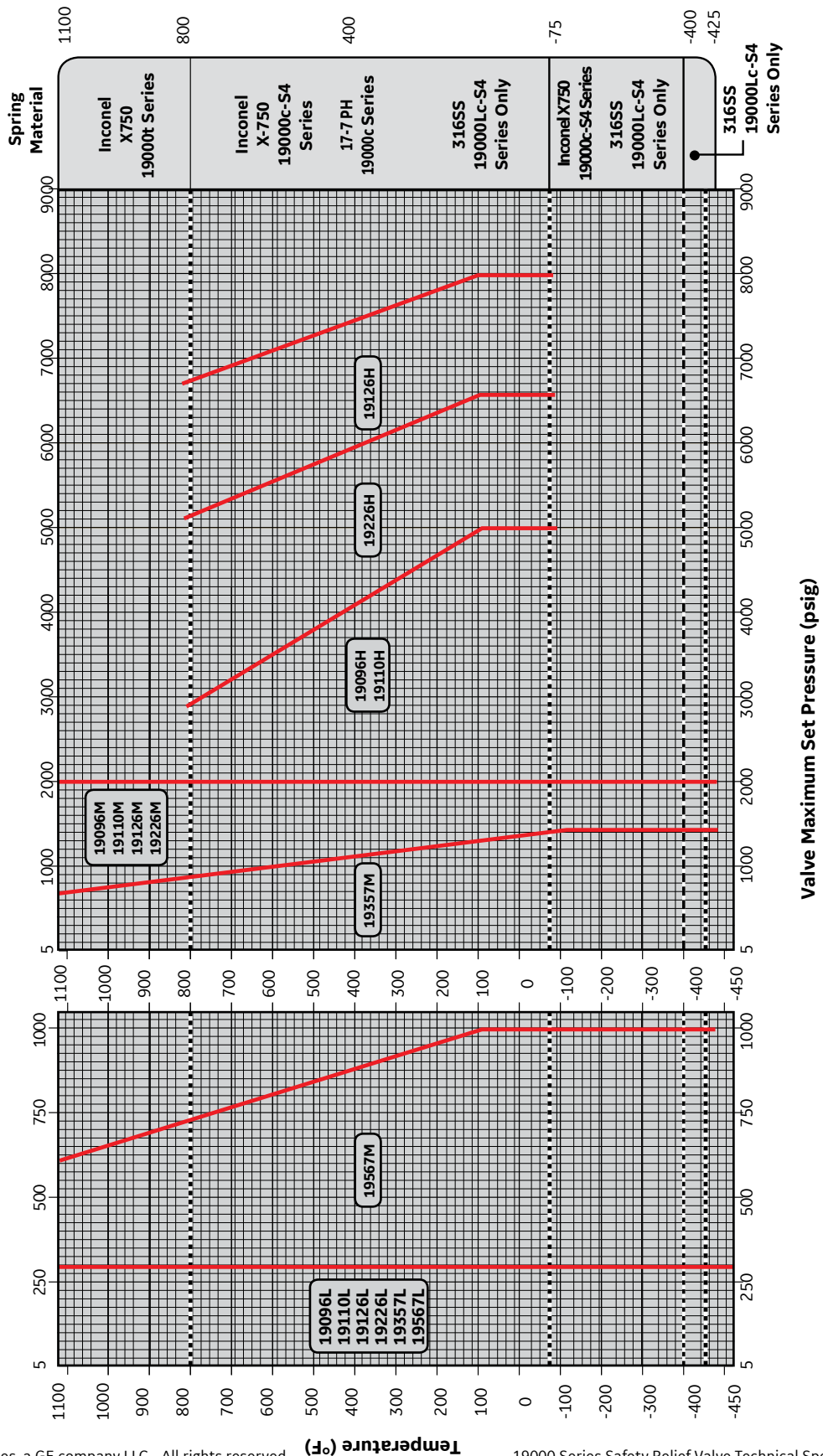

Capacities

Valve Capacity for ASME B&PV Code Section VIII, for Air¹

Based at 10 percent overpressure or 3 psig (0.21 barg), whichever is greater, showing 90 percent of actual capacity in accordance with latest ASME Code requirements. Units of ft³/min (m³/min) of air are at a temperature of 60°F (15.6°C).

Orifice		19096 ²		19110		19126		19226		19357		19567	
Orifice Area		in ²	cm ²	in ²	cm ²	in ²	cm ²	in ²	cm ²	in ²	cm ²	in ²	cm ²
Set Pressure		0.096	0.619	0.110	0.710	0.126	0.813	0.226	1.458	0.357	2.303	0.567	3.658
		Orifice Capacity											
psig	barg	ft ³ /min	m ³ /min	ft ³ /min	m ³ /min	ft ³ /min	m ³ /min	ft ³ /min	m ³ /min	ft ³ /min	m ³ /min	ft ³ /min	m ³ /min
15	1.03	50	1.41	57	1.61	66	1.86	119	3.36	188	5.32	298	8.43
20	1.37	58	1.64	66	1.86	76	2.15	137	3.87	216	6.11	344	9.74
30	2.06	73	2.06	84	2.37	96	2.71	173	4.89	274	7.75	435	12.31
40	2.75	90	2.54	104	2.94	119	3.36	213	6.03	337	9.54	536	15.17
50	3.44	107	3.02	123	3.48	141	3.99	253	7.16	400	11.32	636	18.00
60	4.13	124	3.51	143	4.04	163	4.61	293	8.29	464	13.13	737	20.86
70	4.82	141	3.99	162	4.58	186	5.26	333	9.42	527	14.92	837	23.70
80	5.51	158	4.47	182	5.15	208	5.88	374	10.59	590	16.70	938	26.56
90	6.20	175	4.95	201	5.69	230	6.51	414	11.72	654	18.51	1038	29.39
100	6.89	192	5.43	221	6.25	253	7.16	454	12.85	717	20.30	1139	32.25
120	8.27	226	6.39	260	7.36	297	8.41	534	15.12	843	23.87	1340	37.94
140	9.65	260	7.36	299	8.46	342	9.68	614	17.38	970	27.46	1541	43.63
160	11.03	295	8.35	338	9.57	387	10.95	694	19.65	1097	31.06	1742	49.32
180	12.41	329	9.31	377	10.67	431	12.20	774	21.91	1223	34.63	1943	55.01
200	13.78	363	10.27	416	11.77	476	13.47	854	24.18	1350	38.22	2144	60.71
220	15.16	397	11.24	455	12.88	521	14.75	934	26.44	1476	41.79	2345	66.40
240	16.54	431	12.20	494	13.98	565	15.99	1015	28.74	1603	45.39	2546	72.09
260	17.92	465	13.16	533	15.09	610	17.27	1095	31.00	1729	48.95	2747	77.78
280	19.30	499	14.13	572	16.19	655	18.54	1175	33.27	1856	52.55	2948	83.47
300	20.68	533	15.09	611	17.30	699	19.79	1255	35.53	1983	56.15	3149	89.16
320	22.06	567	16.05	650	18.40	744	21.06	1335	37.80	2109	59.72	3350	94.86
340	23.44	601	17.01	689	19.51	789	22.34	1415	40.06	2236	63.31	3551	100.55
360	24.82	635	17.98	728	20.61	833	23.58	1495	42.33	2362	66.88	3752	106.24
380	26.20	669	18.94	767	21.71	878	24.86	1575	44.59	2489	70.48	3953	111.93
400	27.57	703	19.90	806	22.82	923	26.13	1656	46.89	2615	74.04	4154	117.62
420	28.95	737	20.86	845	23.92	967	27.38	1736	49.15	2742	77.64	4355	123.31
440	30.33	771	21.83	884	25.03	1012	28.65	1816	51.42	2869	81.24	4556	129.01
460	31.71	805	22.79	923	26.13	1057	29.93	1896	53.68	2995	84.80	4757	134.70
480	33.09	839	23.75	962	27.24	1101	31.17	1976	55.95	3122	88.40	4958	140.39
500	34.47	873	24.72	1001	28.34	1146	32.45	2056	58.21	3248	91.97	5159	146.08

Note:

1. 19096M-BP set pressure range is 50 to 2000 psig (3.45 to 137.90 barg).

Capacities

Valve Capacity for ASME B&PV Code Section VIII, for Air ¹													
Based at 10 percent overpressure or 3 psig (0.21 barg), whichever is greater, showing 90 percent of actual capacity in accordance with latest ASME Code requirements. Units of ft ³ /min (m ³ /min) of air are at a temperature of 60°F (15.6°C).													
Orifice		19096 ²		19110		19126		19226		19357		19567	
Orifice Area		in ²	cm ²	in ²	cm ²	in ²	cm ²	in ²	cm ²	in ²	cm ²	in ²	cm ²
		0.096	0.619	0.110	0.710	0.126	0.813	0.226	1.458	0.357	2.303	0.567	3.658
Set Pressure		Orifice Capacity											
psig	barg	ft ³ /min	m ³ /min	ft ³ /min	m ³ /min	ft ³ /min	m ³ /min	ft ³ /min	m ³ /min	ft ³ /min	m ³ /min	ft ³ /min	m ³ /min
600	41.36	1043	29.53	1196	33.86	1370	38.79	2457	69.57	3881	109.89	6165	174.57
700	48.26	1213	34.34	1391	39.38	1593	45.10	2857	80.90	4514	127.82	7170	203.03
750	51.71	1299	36.78	1488	42.13	1705	48.28	3058	86.59	4830	136.77	7672	217.24
800	55.15	1384	39.19	1586	44.91	1816	51.42	3258	92.25	5147	145.74	8175	231.49
900	62.05	1554	44.00	1781	50.43	2040	57.76	3659	103.61	5780	163.67	9180	259.94
1000	68.94	1724	48.81	1976	55.95	2263	64.08	4059	114.93	6413	181.59	10185	288.40
1100	75.84	1894	53.63	2171	61.47	2486	70.39	4460	126.29	7045	199.49	-	-
1200	82.73	2064	58.44	2366	66.99	2710	76.73	4861	137.64	7678	217.41	-	-
1300	89.63	2235	63.28	2561	72.51	2933	83.05	5261	148.97	8311	235.34	-	-
1400	96.52	2405	68.10	2756	78.04	3156	89.36	5662	160.33	8944	253.26	-	-
1500	103.42	2575	72.91	2951	83.56	3380	95.71	6062	171.65	9577	271.19	-	-
1600	110.31	2745	77.72	3146	89.08	3603	102.02	6463	183.01	-	-	-	-
1700	117.21	2915	82.54	3341	94.60	3826	108.34	6864	194.36	-	-	-	-
1800	124.10	3085	87.35	3535	100.10	4050	114.68	7264	205.69	-	-	-	-
1900	131.00	3256	92.19	3730	105.62	4273	120.99	7665	217.04	-	-	-	-
2000	137.89	3426	97.01	3925	111.14	4497	127.34	8066	228.40	-	-	-	-
2500	172.36	4277	121.11	4900	138.75	5613	158.94	10069	285.12	-	-	-	-
3000	206.84	5128	145.20	5875	166.36	6730	190.57	12072	341.84	-	-	-	-
3500	241.31	5979	169.30	6850	193.97	7847	222.20	14075	398.55	-	-	-	-
4000	275.79	6829	193.37	7825	221.57	8964	253.83	16078	455.27	-	-	-	-
4500	310.26	7680	217.47	8800	249.18	10081	285.46	18081	511.99	-	-	-	-
5000	344.73	8531	241.57	9775	276.79	11197	317.06	20085	568.74	-	-	-	-
5500	379.21	-	-	-	-	12314	348.69	22088	625.46	-	-	-	-
6000	413.68	-	-	-	-	13431	380.32	24091	682.18	-	-	-	-
6400	441.26	-	-	-	-	14324	405.61	25693	727.54	-	-	-	-
6500	448.15	-	-	-	-	14548	411.95	-	-	-	-	-	-
7000	482.63	-	-	-	-	15665	443.58	-	-	-	-	-	-
7500	517.10	-	-	-	-	16781	475.18	-	-	-	-	-	-
8000	551.58	-	-	-	-	17898	506.81	-	-	-	-	-	-

Note:

1. 19096M-BP set pressure range is 50 to 2000 psig (3.45 to 137.90 barg).

Capacities

Valve Capacity for ASME B&PV Code Section VIII, for Saturated Steam¹

Based at 10 percent overpressure or 3 psig (0.21 barg), whichever is greater, showing 90 percent of actual capacity in accordance with latest ASME Code requirements.

Orifice		19096 ²		19110		19126		19226		19357		19567	
Orifice Area		in ²	cm ²	in ²	cm ²	in ²	cm ²	in ²	cm ²	in ²	cm ²	in ²	cm ²
Set Pressure		0.096	0.619	0.110	0.710	0.126	0.813	0.226	1.458	0.357	2.303	0.567	3.658
Orifice Capacity													
psig	barg	lb/hr	kg/hr	lb/hr	kg/hr	lb/hr	kg/hr	lb/hr	kg/hr	lb/hr	kg/hr	lb/hr	kg/hr
15	1.03	141	63	162	73	186	84	334	151	527	239	838	380
20	1.37	163	73	187	84	214	97	385	174	608	275	966	438
30	2.06	207	93	237	107	271	122	487	220	769	348	1222	554
40	2.75	254	115	291	131	334	151	599	271	947	429	1504	682
50	3.44	302	136	346	156	397	180	712	322	1125	510	1786	810
60	4.13	350	158	401	181	459	208	824	373	1302	590	2068	938
70	4.82	398	180	456	206	522	236	937	425	1480	671	2351	1066
80	5.51	445	201	510	231	585	265	1049	475	1657	751	2633	1194
90	6.20	493	223	565	256	647	293	1161	526	1835	832	2915	1322
100	6.89	541	245	620	281	710	322	1274	577	2012	912	3197	1450
120	8.27	636	288	729	330	835	378	1499	679	2368	1074	3761	1705
140	9.65	732	332	839	380	961	435	1723	781	2723	1235	4325	1961
160	11.03	827	375	948	430	1086	492	1948	883	3078	1396	4889	2217
180	12.41	923	418	1057	479	1211	549	2173	985	3433	1557	5453	2473
200	13.78	1018	461	1167	529	1337	606	2398	1087	3788	1718	6017	2729
220	15.16	1114	505	1276	578	1462	663	2623	1189	4143	1879	6581	2985
240	16.54	1209	548	1386	628	1587	719	2848	1291	4498	2040	7145	3240
260	17.92	1305	591	1495	678	1713	777	3072	1393	4854	2201	7709	3496
280	19.30	1400	635	1605	728	1838	833	3297	1495	5209	2362	8273	3752
300	20.68	1496	678	1714	777	1963	890	3522	1597	5564	2523	8837	4008
320	22.06	1591	721	1823	826	2089	947	3747	1699	5919	2684	9401	4264
340	23.44	1687	765	1933	876	2214	1004	3972	1801	6274	2845	9965	4520
360	24.82	1782	808	2042	926	2339	1060	4196	1903	6629	3006	10529	4775
380	26.20	1878	851	2152	976	2465	1118	4421	2005	6984	3167	11093	5031
400	27.57	1973	894	2261	1025	2590	1174	4646	2107	7339	3328	11657	5287
420	28.95	2069	938	2371	1075	2715	1231	4871	2209	7695	3490	12221	5543
440	30.33	2164	981	2480	1124	2841	1288	5096	2311	8050	3651	12785	5799
460	31.71	2260	1025	2589	1174	2966	1345	5321	2413	8405	3812	13349	6055
480	33.09	2355	1068	2699	1224	3091	1402	5545	2515	8760	3973	13913	6310
500	34.47	2451	1111	2808	1273	3217	1459	5770	2617	9115	4134	14477	6566
600	41.36	2928	1328	3355	1521	3843	1743	6894	3127	10891	4940	17297	7845
700	48.26	3406	1544	3902	1769	4470	2027	8018	3636	12666	5745	20118	9125
750	51.71	3644	1652	4176	1894	4784	2169	8580	3891	13554	6147	21528	9764
800	55.15	3883	1761	4450	2018	5097	2311	9142	4146	14442	6550	22938	10404
900	62.05	4361	1978	4997	2266	5724	2596	10267	4657	16218	7356	25758	11683
1000	68.94	4838	2194	5544	2514	6350	2880	11391	5166	17994	8161	28578	12962
1100	75.84	5316	2411	6091	2762	6977	3164	12515	5676	19769	8967	-	-
1200	82.73	5793	2627	6638	3010	7604	3449	13639	6186	21545	9772	-	-
1300	89.63	6271	2844	7185	3259	8230	3733	14763	6696	23321	10578	-	-
1400	96.52	6748	3060	7732	3507	8857	4017	15887	7206	25096	11383	-	-
1423 ³	98.11	6858	3110	7858	3564	9001	4082	16146	7323	25505	11568	-	-
1500	103.42	7260	3293	8319	3773	9529	4322	17093	7753	27001	12247	-	-
1600	110.31	7792	3534	8928	4049	10227	4638	18343	8320	-	-	-	-
1700	117.21	8333	3779	9549	4331	10938	4961	19619	8899	-	-	-	-
1800	124.10	8888	4031	10184	4619	11665	5291	20923	9490	-	-	-	-
1900	131.00	9455	4288	10834	4914	12410	5629	22260	10096	-	-	-	-
2000	137.89	10039	4553	11503	5217	13176	5976	23633	10719	-	-	-	-
2500	172.36	13285	6025	15222	6904	17436	7908	31275	14186	-	-	-	-
2903 ⁴	200.15	16611	7534	19033	8633	21802	9889	39106	17738	-	-	-	-

Notes:

- 19096M-BP set pressure range is 50 to 2000 psig (3.45 to 137.9 barg).
- The following Napier Factor is applied to the capacity of pressures greater than 1423 psig (98.11 barg):
- Maximum permissible set pressure on steam is 2903 psig (200.15). Value has been interpolated.

$$\left[\frac{0.1906 \times P_{psia} - 1000}{0.2292 \times P_{psia} - 1061} \right]$$

Capacities

Valve Capacity for ASME B&PV Code Section VIII, for Water¹

Based at 10 percent overpressure or 3 psig (0.21 barg), whichever is greater, with zero backpressure. Units of gal/min (L/min) at 70°F (21.1°C), showing 90 percent average capacity in accordance with latest ASME Code requirements.

Orifice		19096 ²		19110		19126		19226		19357		19567	
Orifice Area		in ²	cm ²	in ²	cm ²	in ²	cm ²	in ²	cm ²	in ²	cm ²	in ²	cm ²
		0.096	0.619	0.110	0.710	0.126	0.813	0.226	1.458	0.357	2.303	0.567	3.658
Set Pressure		Orifice Capacity											
psig	barg	gal/min	L/min	gal/min	L/min	gal/min	L/min	gal/min	L/min	gal/min	L/min	gal/min	L/min
15	1.03	10	38	9	34	13	49	24	91	38	144	61	231
20	1.37	11	42	10	37	15	57	27	102	43	163	69	261
30	2.06	14	53	12	45	18	68	33	125	52	197	83	314
40	2.75	16	61	15	56	21	79	38	144	60	227	96	363
50	3.44	18	68	16	60	23	87	42	159	67	254	107	405
60	4.13	19	72	18	68	26	98	46	174	74	280	117	443
70	4.82	21	79	19	71	28	106	50	189	80	303	127	481
80	5.51	23	87	21	79	30	114	54	204	85	322	136	515
90	6.20	24	91	22	83	32	121	57	216	90	341	144	545
100	6.89	25	95	23	87	33	125	60	227	95	360	152	575
120	8.27	28	106	25	94	37	140	66	250	104	394	166	628
140	9.65	30	114	28	105	39	148	71	269	113	428	179	678
160	11.03	32	121	30	113	42	159	76	288	121	458	192	727
180	12.41	34	129	31	117	45	170	81	307	128	485	204	772
200	13.78	36	136	33	124	47	178	85	322	135	511	215	814
220	15.16	38	144	35	132	50	189	89	337	142	538	225	852
240	16.54	39	148	36	136	52	197	93	352	148	560	235	890
260	17.92	41	155	38	143	54	204	97	367	154	583	245	927
280	19.30	43	163	39	147	56	212	101	382	160	606	254	961
300	20.68	44	167	41	155	58	220	104	394	165	625	263	996
320	22.06	46	174	42	158	60	227	108	409	171	647	272	1030
340	23.44	47	178	43	162	62	235	111	420	176	666	280	1060
360	24.82	48	182	45	170	64	242	115	435	181	685	288	1090
380	26.20	50	189	46	174	65	246	118	447	186	704	296	1120
400	27.57	51	193	47	177	67	254	121	458	191	723	304	1151
420	28.95	52	197	48	181	69	261	124	469	196	742	311	1177
440	30.33	54	204	49	185	70	265	127	481	200	757	319	1208
460	31.71	55	208	50	189	72	273	130	492	205	776	326	1234
480	33.09	56	212	51	193	74	280	132	500	209	791	333	1261
500	34.47	57	216	53	200	75	284	135	511	214	810	340	1287
600	41.36	63	238	58	219	82	310	148	560	234	886	372	1408
700	48.26	68	257	62	234	89	337	160	606	253	958	402	1522
750	51.71	70	265			92	348	166	628	262	992	416	1575
800	55.15	72	273	67	253	95	360	171	647	270	1022	430	1628
900	62.05	77	291	71	268	101	382	181	685	287	1086	456	1726
1000	68.94	81	307	75	283	106	401	191	723	302	1143	480	1817
1100	75.84	85	322	78	295	112	424	201	761	317	1200	-	-
1200	82.73	89	337	82	310	117	443	209	791	331	1253	-	-
1300	89.63	92	348	85	321	121	458	218	825	345	1306	-	-
1400	96.52	96	363	88	333	126	477	226	856	358	1355	-	-
1500	103.42	99	375	91	344	130	492	234	886	370	1401	-	-
1600	110.31	102	386	94	355	135	511	242	916	-	-	-	-
1700	117.21	106	401	97	367	139	526	249	943	-	-	-	-
1800	124.10	109	413	100	378	143	541	257	973	-	-	-	-
1900	131.00	112	424	103	389	147	556	264	999	-	-	-	-
2000	137.89	115	435	106	401	151	572	271	1026	-	-	-	-
2500	172.36	128	485	118	446	168	636	303	1147	-	-	-	-
3000	206.84	141	534	129	488	185	700	332	1257	-	-	-	-
3500	241.31	152	575	140	529	199	753	358	1355	-	-	-	-
4000	275.79	162	613	150	567	213	806	383	1450	-	-	-	-
4500	310.26	172	651	159	601	226	856	406	1537	-	-	-	-
5000	344.73	182	689	167	632	238	901	428	1620	-	-	-	-
5500	379.21	-	-	-	-	250	946	449	1700	-	-	-	-
6000	413.68	-	-	-	-	261	988	469	1775	-	-	-	-
6400	441.26	-	-	-	-	270	1022	484	1832	-	-	-	-
6500	448.15	-	-	-	-	272	1030	-	-	-	-	-	-
7000	482.63	-	-	-	-	282	1067	-	-	-	-	-	-
7500	517.10	-	-	-	-	292	1105	-	-	-	-	-	-
8000	551.58	-	-	-	-	302	1143	-	-	-	-	-	-

Notes:

1. 19096M-BP set pressure range is 50 to 2000 psig (3.45 to 137.90 barg).

2. The following Napier Factor is applied to the capacity of pressures greater than 1423 psig (98.11 barg):

$$\left[\frac{0.1906 \times P_{psia} - 1000}{0.2292 \times P_{psia} - 1061} \right]$$

Safety Valve Configuration Code

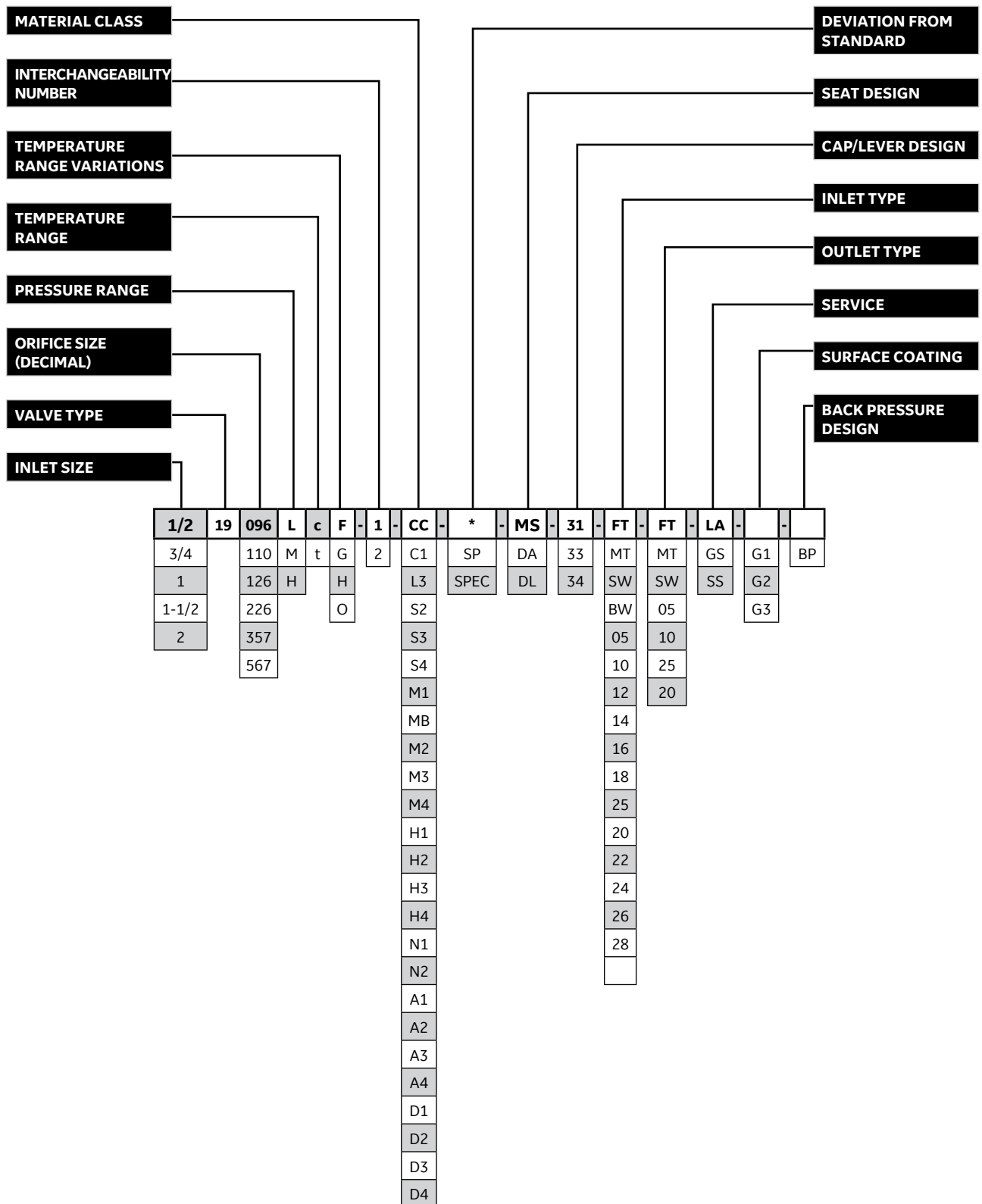

Safety Valve Configuration Code

Orifice Area		
Designation	Area	
	in ²	cm ²
096	0.096	0.619
110	0.110	0.710
126	0.126	0.813
226	0.226	1.458
357	0.357	2.303
567	0.567	3.658

Backpressure Design	
Designation	Description
BP	Medium Pressure [50 - 2000 psig (3.45-137.90 barg)] Maximum B/P 400 psig (27.58 barg)

Temperature Class	
Designation	Class
c	≤ 800°F (427°C)
t	> 800°F (427°C)

Service	
Designation	Description
GS	Gas, Air
LA	Liquid
SS	Steam

Cap/Lever Design	
Designation	Description
31	Screwed
33	Packed
34	Plain

Pressure Range				
Designation	Range			
	min.		max.	
	psig	barg	psig	barg
L	5	0.34	290	19.99
M	291	20.06	2000	137.90
H	2001	137.96	8000	551.58

Temperature Range Variations	
Designation	Range
F	All Temps. (MS)
G	> 250°F (121°C) (SS/MS)
H	> 250°F (121°C) (SG/MS)
O	DA (SOFT SEAT)

Surface Coating	
Designation	Description
G1	Glide Alloy Disc Holder
G2	Glide Alloy Guide
G3	Guide Alloy Disc Holder and Guide

Surface Coating	
Designation	Description
MS	Metal Seat
DA	Soft Seat
DL	Soft Seat Liquid Service Pressures ≤ 100 psig (6.89 barg) (Except 110 Orifice)

Pressure Range	
Designation	Variation
CC	Standard Material
C1	Ambient Temp. to -50°F (-45.6°C) [LCC Construction]
L3	Low Temperature Service [-151 to -450°F (-102 to -268°C)]
S2	Stainless Steel [Internals, Except Spring Assy.]
S3	Stainless Steel [All Except Spring Assy.]
S4	Stainless Steel [Complete Valve]
M1	Monel [Base & Disc]
MB	Monel [M1+Disc Holder]
M2	Monel [Internals, Except Spring Assy.]
M3	Monel [All Except Spring Assy.]
M4	Monel [Complete Valve]
H1	Hastelloy [Base & Disc]
H2	Hastelloy [Internals, Except Spring Assy.]
H3	Hastelloy [All Except Spring Assy.]
H4	Hastelloy [Complete Valve]
N1	Sour Gas
N2	Sour Gas (Stainless Steel)
A1	Alloy 20 [Base & Disc]
A2	Alloy 20 [Internals, Except Spring Assy.]
A3	Alloy 20 [All Except Spring Assy.]
A4	Alloy 20 [Complete Valve]
D1	Duplex [Base & Disc]
D2	Duplex [Internals, Except Spring Assy.]
D3	Duplex [All Except Spring Assy.]
D4	Duplex [Complete Valve]

Safety Valve Configuration Code

Inlet Connection Type	
Designation	Variation
FT	Female NPT
MT	Male NPT
SW	Socket Weld
BW	Buttweld
05	150# Flanged Raised Face
10	300# Flanged Raised Face
12	600# Flanged Raised Face
14	900# Flanged Raised Face
16	1500# Flanged Raised Face
18	2500# Flanged Raised Face
25	150# Flanged Ring Joint
20	300# Flanged Ring Joint
22	600# Flanged Ring Joint
24	900# Flanged Ring Joint
26	1500# Flanged Ring Joint
28	2500# Flanged Ring Joint

Outlet Connection Type	
Designation	Variation
FT	Female NPT
MT	Male NPT
SW	Socket Weld
05	150# Flanged Raised Face
10	300# Flanged Raised Face
25	150# Flanged Ring Joint
20	300# Flanged Ring Joint

Interchangeability	
Designation	Valve Type
1	Existing Soft Seat (DA & DL) Previous Metal Seat (MS)
2	Existing Metal Seat (MS)

Ordering a 19000 Safety Relief Valve

Specification Sheet			
		Page_____ of_____	
Requisition No.	_____		
Job No.	_____		
Date	_____		
Revised By	_____		
General			
1.	Item Number:		
2.	Tag Number:		
3.	Service, Line or Equipment No:		
4.	Number Required:		
Basis of Selection			
5.	Code:		
		<input type="checkbox"/> ASME Sec. III	
		<input type="checkbox"/> ASME Sec. VIII	
		<input type="checkbox"/> OTHER Specify:	
6.	<input type="checkbox"/> Fire <input type="checkbox"/> OTHER Specify:		
7.	Rupture Disk: <input type="checkbox"/> YES <input type="checkbox"/> NO		
Valve Design			
8.	Type: Safety Relief		
9.	Design:		
		<input type="checkbox"/> Metal Seat <input type="checkbox"/> Resilient Seat	
		<input type="checkbox"/> API 527 Seat Tightness	
		<input type="checkbox"/> OTHER Specify:	
Connections			
10.	Flanged		
	Inlet Size:	Rating:	Facing:
	Outlet Size:	Rating:	Facing:
11.	Threaded		
	Inlet:	<input type="checkbox"/> MNPT	<input type="checkbox"/> FNPT
	Outlet:	<input type="checkbox"/> MNPT	<input type="checkbox"/> FNPT
12.	<input type="checkbox"/> OTHER Specify:		
Materials			
13.	Base:		
14.	Bonnet:		
15.	Guide/Rings:		
16.	Seat Material:		
	Metal:		
	Resilient:		
17.	Spring:		
18.	Comply with NACE MRO 175 <input type="checkbox"/> YES <input type="checkbox"/> NO		
19.	<input type="checkbox"/> OTHER Specify:		
20.	Cap and Lever Selection		
	<input type="checkbox"/> Screwed Cap (Standard) <input type="checkbox"/> Bolted Cap		
	<input type="checkbox"/> Plain Lever <input type="checkbox"/> Packed Lever <input type="checkbox"/> Gag		
21.	<input type="checkbox"/> OTHER Specify:		
Service Conditions			
22.	Fluid and State:		
23.	Required Capacity per Valve & Units:		
24.	Molecular Weight or Specific Gravity:		
25.	Viscosity at Flowing Temperature & Units:		
26.	Operating Pressure & Units:		
27.	Blowdown: <input type="checkbox"/> Standard <input type="checkbox"/> Other		
28.	Latent Heat of Vaporization & Units:		
29.	Operating Temperature & Units:		
30.	Relieving Temperature & Units:		
31.	Built-up Back Pressure & Units:		
32.	Superimposed Back Pressure & Units:		
33.	Cold differential Test Pressure & Units:		
34.	Allowable Overpressure in Percent or Units:		
35.	Compressibility Factor, Z:		
36.	Ratio of Specific Heats:		
Sizing and Selection			
37.	Calculated Orifice Area: _____ in ² _____ cm ²		
38.	Selected Orifice Area: _____ in ² _____ cm ²		
39.	Orifice Designation (letter):		
40.	Manufacturer:		
41.	Model Number:		
42.	Vendor Calculations Required: <input type="checkbox"/> YES <input type="checkbox"/> NO		

DIRECT SALES OFFICE LOCATIONS

AUSTRALIA

Brisbane:
Phone: +61-7-3001-4319
Fax: +61-7-3001-4399

Perth:
Phone: +61-8-6595-7018
Fax: +61-8-6595-7299

Melbourne:
Phone: +61-3-8807-6002
Fax: +61-3-8807-6577

BELGIUM
Phone: +32-2-344-0970
Fax: +32-2-344-1123

BRAZIL
Phone: +55-19-2104-6900

CHINA
Phone: +86-10-5738-8888
Fax: +86-10-5918-9707

FRANCE
Courbevoie
Phone: +33-1-4904-9000
Fax: +33-1-4904-9010

GERMANY
Ratingen
Phone: +49-2102-108-0
Fax: +49-2102-108-111

INDIA
Mumbai
Phone: +91-22-8354790
Fax: +91-22-8354791

New Delhi
Phone: +91-11-2-6164175
Fax: +91-11-5-1659635

ITALY

Phone: +39-081-7892-111
Fax: +39-081-7892-208

JAPAN

Tokyo
Phone: +81-03-6871-9008
Fax: +81-03-6890-4620

KOREA

Phone: +82-2-2274-0748
Fax: +82-2-2274-0794

MALAYSIA

Phone: +60-3-2161-0322
Fax: +60-3-2163-6312

MEXICO

Phone: +52-55-3640-5060

THE NETHERLANDS

Phone: +31-15-3808666

RUSSIA

Veliky Novgorod
Phone: +7-8162-55-7898
Fax: +7-8162-55-7921

Moscow

Phone: +7 495-585-1276
Fax: +7 495-585-1279

SAUDI ARABIA

Phone: +966-3-341-0278
Fax: +966-3-341-7624

SINGAPORE

Phone: +65-6861-6100
Fax: +65-6861-7172

SOUTH AFRICA

Phone: +27-11-452-1550
Fax: +27-11-452-6542

SOUTH & CENTRAL

AMERICA AND THE CARIBBEAN
Phone: +55-12-2134-1201
Fax: +55-12-2134-1238

SPAIN

Phone: +34-93-652-6430
Fax: +34-93-652-6444

UNITED ARAB EMIRATES

Phone: +971-4-8991-777
Fax: +971-4-8991-778

UNITED KINGDOM

Bracknell
Phone: +44-1344-460-500
Fax: +44-1344-460-537

Skelmersdale

Phone: +44-1695-526-00
Fax: +44-1695-526-01

UNITED STATES

Jacksonville, Florida
Phone: +1-904-570-3409

Deer Park, Texas

Phone: +1-281-884-1000
Fax: +1-281-884-1010

Houston, Texas

Phone: +1-281-671-1640
Fax: +1-281-671-1735

bhge.com

*Denotes a trademark of Baker Hughes, a GE company, LLC.

Other company names and product names used in this document are the registered trademarks or trademarks of their respective owners.

© 2018 Baker Hughes, a GE company LLC - All rights reserved.

Baker Hughes, a GE company, LLC and its affiliates ("BHGE") provides this information on an "as is" basis for general information purposes and believes it to be accurate as of the date of publication. BHGE does not make any representation as to the accuracy or completeness of the information and makes no warranties of any kind, specific, implied or oral, to the fullest extent permissible by law, including those of merchantability and fitness for a particular purpose or use. BHGE hereby disclaims any and all liability for any direct, indirect, consequential or special damages, claims for lost profits, or third party claims arising from the use of the information, whether a claim is asserted in contract, tort, or otherwise. The BHGE logo is a trademark of Baker Hughes, a GE company LLC. GE and the GE monogram are trademarks of the General Electric Company used under trademark license.

GEA19546D 09/2018

**BAKER
HUGHES**
a GE company

