

Consolidated* **3500-1/2/3 Series**⁽¹⁾

Electromatic* Ball Valve System

Provides automatic or manual overpressure
startup for steam boiler systems
and assists startup and shutdown venting



⁽¹⁾ The -1/2/3 variations have been obsoleted.
Refer to GEA32632 for latest 3500 EBV Series Tech Specifications.

Table of Contents

- Conversion Table.....2
- Scope of Design3
- Materials4-6
- Options6
- Dimensions and Weights - 3500 Flange x Flange7-9
- Dimensions and Weights - 3500 Butt Weld x Flange 10-12
- Pressure / Temperature - 3500 Flanged End and Buttweld End 13-14
- Orifice Capacities..... 15-30
- Reduced Bore Selection and Capacity Factor 30
- Orifice Capacities..... 31
- Reaction Forces..... 31
- Reaction Forces - Steam..... 32
- Superhead Correction Factor..... 33
- Valve Configuration Code 34
- How to Order a 3500 Safety Valve 35

BHGE provides a full range of Consolidated pressure relief valve styles, sizes, options and configurations for multiple industries, applications, environments, and media. From spring-actuated to pilot-operated, each pressure relief valve is configured to offer safer process flow control in harsh environments.

Conversion Table

All the United States Customary System (USCS) values are converted to metric values using the following conversion factors:

USCS Unit	Conversion Factor	Metric Unit
in.	25.4	mm
lb.	0.4535924	kg
in ²	6.4516	cm ²
ft ³ /min	0.02831685	m ³ /min
gal/min	3.785412	L/min
lb/hr	0.4535924	kg/hr
psig	0.06894757	barg
ft lb	1.3558181	Nm
°F	5/9 (°F-32)	°C

Scope of Design



Standard Valve Connections										
Valve Type	Bore Size		Orifice Area		Inlet			Outlet		
					Size		ANSI Standard Class	Size		ANSI Standard Class
	in.	mm	in. ²	cm ²	in.	mm		in.	mm	
3515F	.88	22.2	0.601	3.877	1.50	38.1	1500 Flanged	3.00	76.2	300
3525F	.88	22.2	0.601	3.877	1.50	38.1	2500 Flanged	3.00	76.2	300
3525W	.88	22.2	0.601	3.877	1.50	38.1	2658 LTD Butt weld	3.00	76.2	300
3516F	1.00	25.4	0.785	5.065	2.00	50.8	1500 Flanged	3.00	76.2	300
3526F	1.00	25.4	0.785	5.065	2.00	50.8	2500 Flanged	3.00	76.2	300
3526W	1.00	25.4	0.785	5.065	2.00	50.8	2658 LTD Butt weld	3.00	76.2	300
3517F	1.75	44.5	2.405	15.516	2.50	63.5	1500 Flanged	4.00	101.6	300
3527F	1.75	44.5	2.405	15.516	2.50	63.5	2500 Flanged	4.00	101.6	300
3537W	1.75	44.5	2.405	15.516	2.50	63.5	3092 LTD Butt weld	4.00	101.6	300
3538W	2.00	50.8	3.142	20.271	2.50	63.5	3092 LTD Butt weld	4.00	101.6	900
3547W	1.75	44.5	2.405	15.516	2.50	63.5	4500 LTD Butt weld	4.00	101.6	900

Materials

Top View

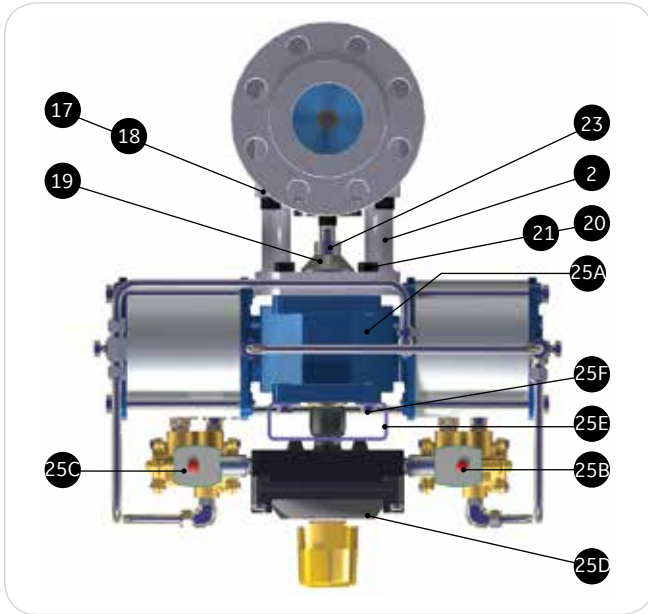

Bottom View

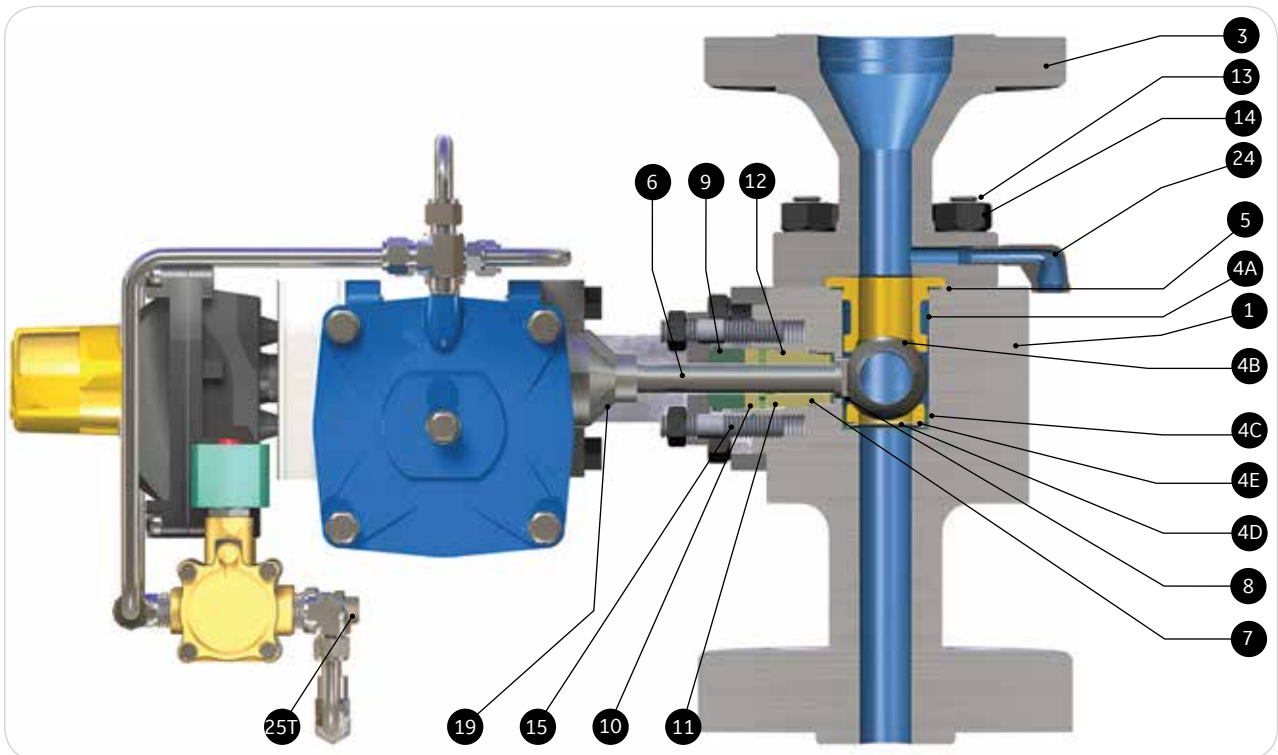

Materials

3500 Materials		
Part No.	Nomenclature	Material
1	Body	
	Flanged	ASME SA217 Gr. WC9
	Buttweld (Standard)	ASME SA182 Gr. F22
	Buttweld (optional)	ASME SA182 Gr. F91
2	Yoke	ASME SA217 Gr. WC9
3	Discharge Collar	ASME SA217 Gr. WC9
4	Ball and Seat Assembly	
4A	Seat	Inconel 718, Colmonoy 69 ¹
4B	Ball	Inconel 718, Colmonoy 69 ¹
4C	Loader	Inconel 718, Colmonoy 69 ¹
4D	Belleville Washer	Type 17-4 PH SS or Inconel
4E	Split Spacer Ring	Type 410 SS, Condition T
5	Gasket	316 Stainless Steel ⁴
6	Stem	ASTM A638 Gr. 660 ²
7	Stem Nut	Type 420 Stainless Steel
8	Bearing Washer	Type 410 Stainless Steel ³
9	Packing Gland Flange	ASME SA105 Carbon Steel
10	Packing Gland	Type 420 Stainless Steel
11	Packing Ring	316 Stainless Steel ⁴
12	Packing Stop Washer	Type 410 SS, Condition T
13	Discharge Collar Studs	ASME SA193 Gr. B16 AS
14	Discharge Collar Nuts	ASME SA194 Gr. 4 AS
15	Stud Packing Gland	ASME SA193 Gr. B16 AS
16	Nut Packing Gland	ASME SA194 Gr. 4 AS
17	Cap Screw Yoke/Body	ASME SA193 Gr. B7 AS
18	Lock Washer Yoke/Body ⁵	Carbon Steel
19	Drive Bushing	Type 410 SS, Condition T
20	Cap Screw Yoke/Actuator	B7 Alloy Steel
21	Lock Washer Yoke/Actuator ⁵	Carbon Steel
22	Key Stem ⁵	Tool Steel
23	Set Screw ⁵	Carbon Steel
24	Drain	Carbon Steel

3500 Materials		
Part No.	Nomenclature	Material
25	Actuator Assembly	
25A	Actuator	Ledeen
25B	Solenoid (Open)	ASCO-Next Generation
25C	Solenoid (Closed)	ASCO-Next Generation
25D	Position Switch (Standard)	Topworx
	Position Switch (Optional)	Westlock
25E	Bracket	Carbon Steel (Commercial)
25F	Cap Screw Bracket/Actuator	Carbon Steel
25G	Lock Washer Bracket/Actuator ⁵	Carbon Steel
25H	Cap Screw Bracket/Switch ⁵	Carbon Steel
25J	Lock Washer Bracket/Switch ⁵	Carbon Steel
25K	Close Nipple Pipe ⁵	Carbon Steel (Galvanized)
25L	Flush Bushing ⁵	Carbon Steel (Galvanized)
25M	Conduit Fitting Straight ⁵	Thomas and Betts
25N	Pipe Plug ⁵	Carbon Steel
25P	Tee Pipe ⁵	Type 316 SS - Swagelok
25Q	Nipple Pipe 6" Length ⁵	Type 316 SS - Swagelok
25R	Elbow Pipe ⁵	Type 316 SS - Swagelok
25S	Tubing ⁵	Type 316 SS - Swagelok
25T	Tube Fitting Union Elbow	Type 316 SS - Swagelok
25U	Tube Fitting Union ⁵	Type 316 SS - Swagelok
25V	Male Branch Tee ⁵	Type 316 SS - Swagelok
25W	Male Run Tee ⁵	Type 316 SS - Swagelok
26	Pressure Regulator	Norgren
27	Filter	Norgren
28	Nipple Pipe 3" Length	Type 316 SS - Swagelok
29	Check Valve	Nupro
30	Cross Pipe	Type 316 Stainless Steel
31	Hex Nipple Pipe	Type 316 SS - Swagelok
32	Thread Protector	Polyethelene
33	Rupture Disc	OSECO

Notes:

1. Spray and Fused Coated.
2. Solution Annealed and Precip. Hardened per Type 1 (Carbide or Nitride Coated).
3. Per BHGE document MA091.
4. With Flexible Graphite Filler (Spiral Wound).
5. Not Shown.

Materials

Options

Pressure Regulator and Filter



Note: A pressure regulator and filter must be installed preceding the 3500 EBV actuator. BHGE can provide a quote for a filter regulator upon request.

Auxiliary Supply Manifold

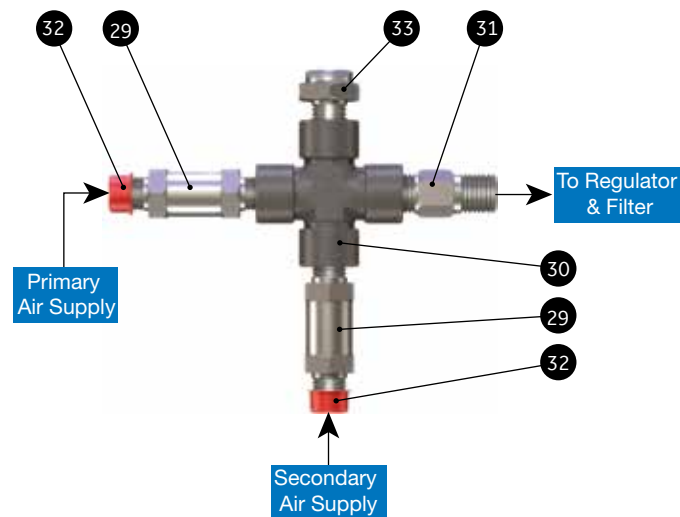

Note: An auxiliary supply manifold can be quoted when an alternate or backup to the instrument air supply is required. The auxiliary supply can be connected to a secondary air supply or nitrogen bottle. In case the regulator on the auxiliary supply pressure fails, a rupture disc is supplied as standard on the auxiliary supply manifold.

Notes:

1. Spray and Fused Coated.
2. Solution Annealed and Precip. Hardened per Type 1 (Carbide or Nitride Coated).
3. Per BHGE document MA091.
4. With Flexible Graphite Filler (Spiral Wound).
5. Not Shown.

Dimensions and Weights

3500 Flange x Flange

3515, 3525, 3516 and 3526F with Ledeen VA123DA Actuator

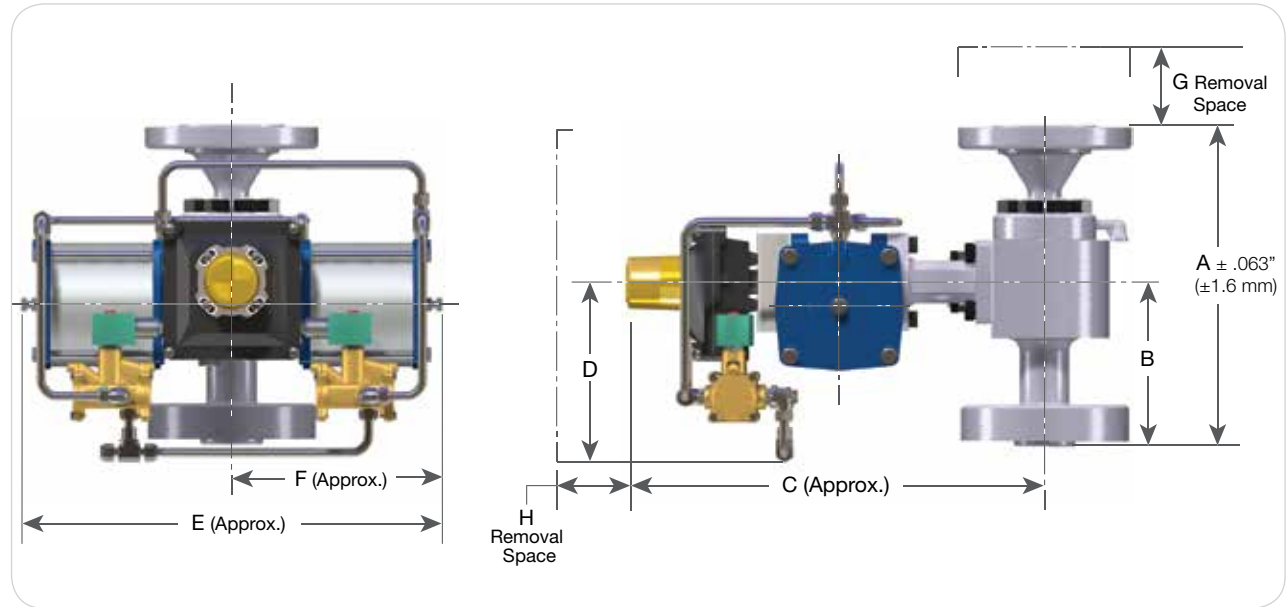

3517 and 3527F with Ledeen VA123DA Actuator

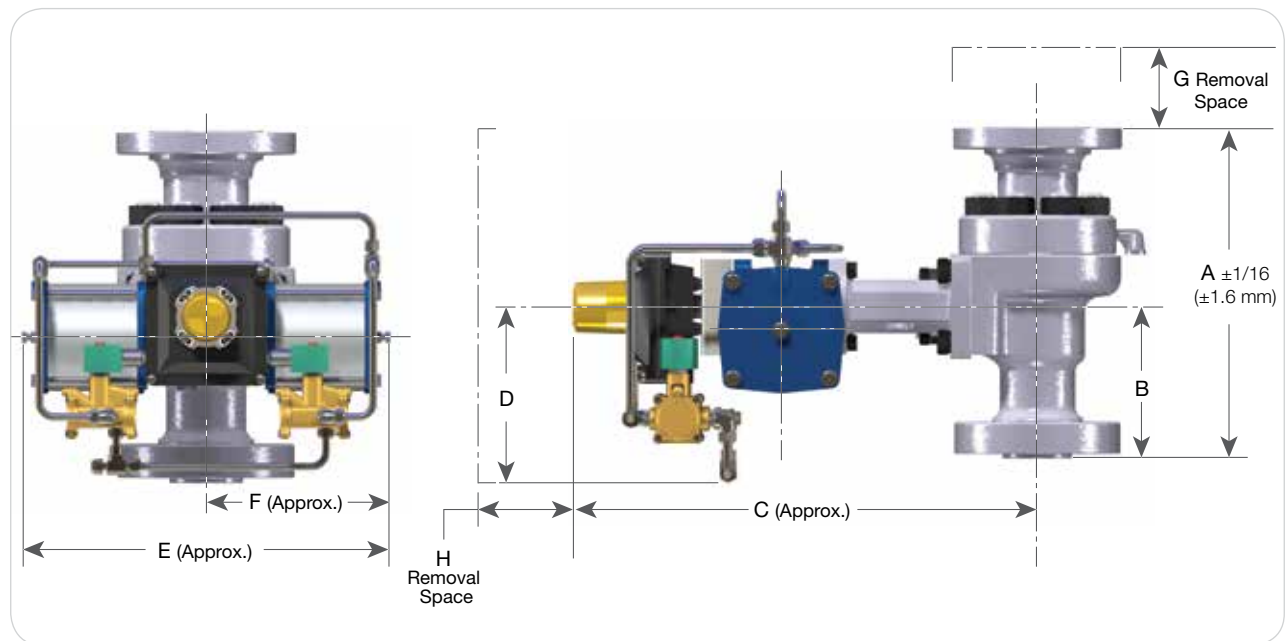

Dimensions and Weights

3500 Flange x Flange

3517 and 3527F with Ledeen GS620 and GS628 Actuators

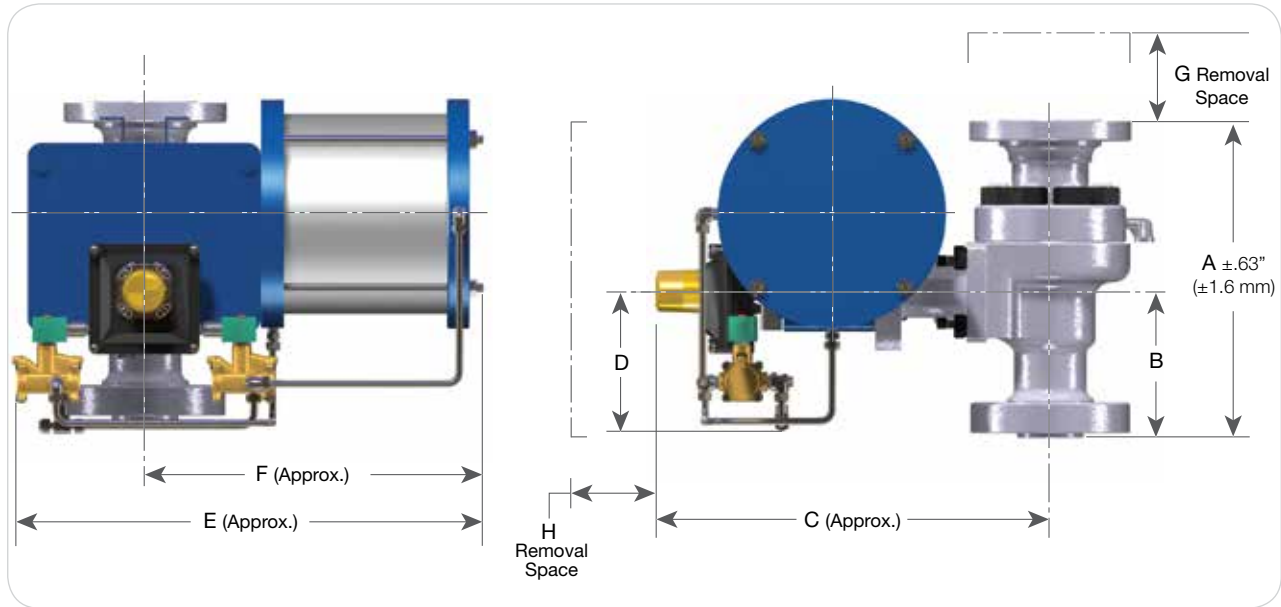

Optional Accessories General Dimensions (Flanged Inlet)

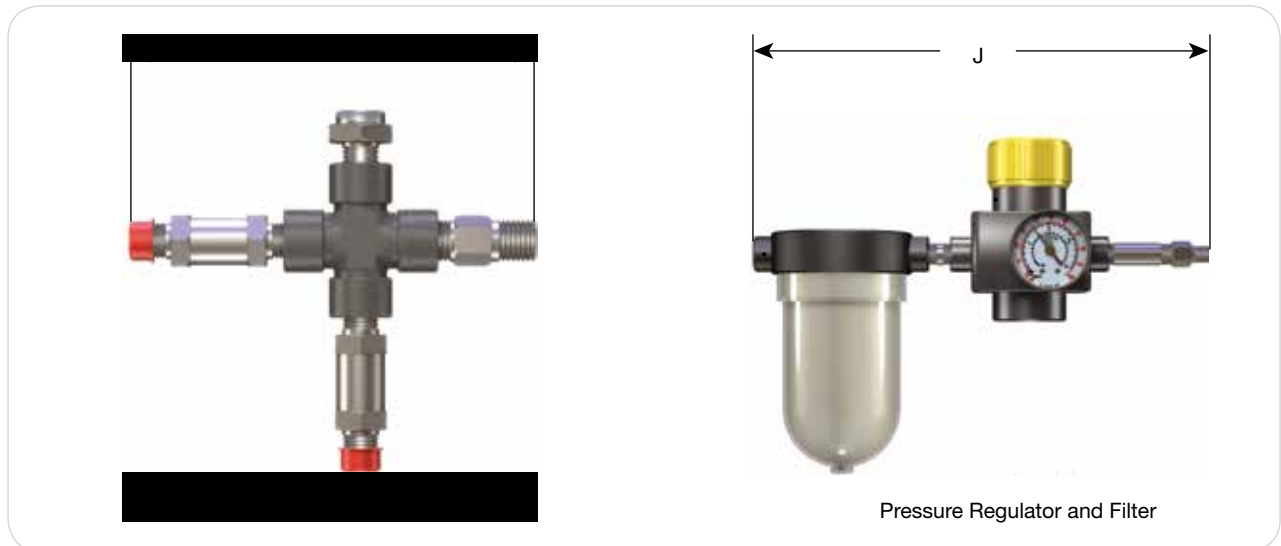

Dimensions and Weights

3500 Flange x Flange

Valve Data - Flanged End													
Valve Type	Actuator Model	General Dimensions											
		A		B		C		D		E		F	
		in.	mm	in.	mm	in.	mm	in.	mm	in.	mm	in.	mm
3515F	VA123DA	15.25	387.4	7.50	190.5	19.50	495.3	6.38	162.1	21.63	549.4	10.81	274.6
3525F	VA123DA	15.75	400.1	8.00	203.2	19.50	495.3	6.38	162.1	21.63	549.4	10.81	274.6
3516F	VA123DA	15.50	393.7	7.75	196.9	19.50	495.3	6.38	162.1	21.63	549.4	10.81	274.6
3526F	VA123DA	16.00	406.4	8.25	209.6	19.50	495.3	6.38	162.1	21.63	549.4	10.81	274.6
3517F	VA123DA	19.00	482.6	8.63	219.2	23.50	596.9	6.38	162.1	21.63	549.4	10.81	274.6
	GS620	19.00	482.6	8.63	219.2	23.50	596.9	6.38	162.1	27.31	693.7	19.56	496.8
	GS628	19.00	482.6	8.63	219.2	23.50	596.9	6.38	162.1	27.31	693.7	19.56	496.8
3527F	VA123DA	19.63	498.6	9.25	235.0	23.50	596.9	6.38	162.1	21.63	549.4	10.81	274.6
	GS620	19.63	498.6	9.25	235.0	23.50	596.9	6.38	162.1	27.31	693.7	19.56	496.8
	GS628	19.63	498.6	9.25	235.0	23.50	596.9	6.38	162.1	27.31	693.7	19.56	496.8

Valve Data - Flanged End											
Valve Type	Actuator Model	General Dimensions								Approximate Weight	
		G		H		J		K			
		in.	mm	in.	mm	in.	mm	in.	mm	lb.	kg
3515F	VA123DA	3.00	76.2	5.00	127.0	7.50	190.5	7.00	177.8	212	96.2
3525F	VA123DA	3.00	76.2	5.00	127.0	7.50	190.5	7.00	177.8	212	96.2
3516F	VA123DA	3.00	76.2	5.00	127.0	7.50	190.5	7.00	177.8	212	96.2
3526F	VA123DA	3.00	76.2	5.00	127.0	7.50	190.5	7.00	177.8	212	96.2
3517F	VA123DA	4.50	114.3	7.50	190.5	7.50	190.5	7.00	177.8	212	96.2
	GS620	4.50	114.3	7.50	190.5	7.50	190.5	7.00	177.8	520	235.9
	GS628	4.50	114.3	7.50	190.5	7.50	190.5	7.00	177.8	546	247.7
3527F	VA123DA	4.50	114.3	7.50	190.5	7.50	190.5	7.00	177.8	212	96.2
	GS620	4.50	114.3	7.50	190.5	7.50	190.5	7.00	177.8	520	235.9
	GS628	4.50	114.3	7.50	190.5	7.50	190.5	7.00	177.8	546	247.7

Dimensions and Weights

3500 Butt weld x Flange

3525W and 3526W with Ledeen VA123DA Actuator

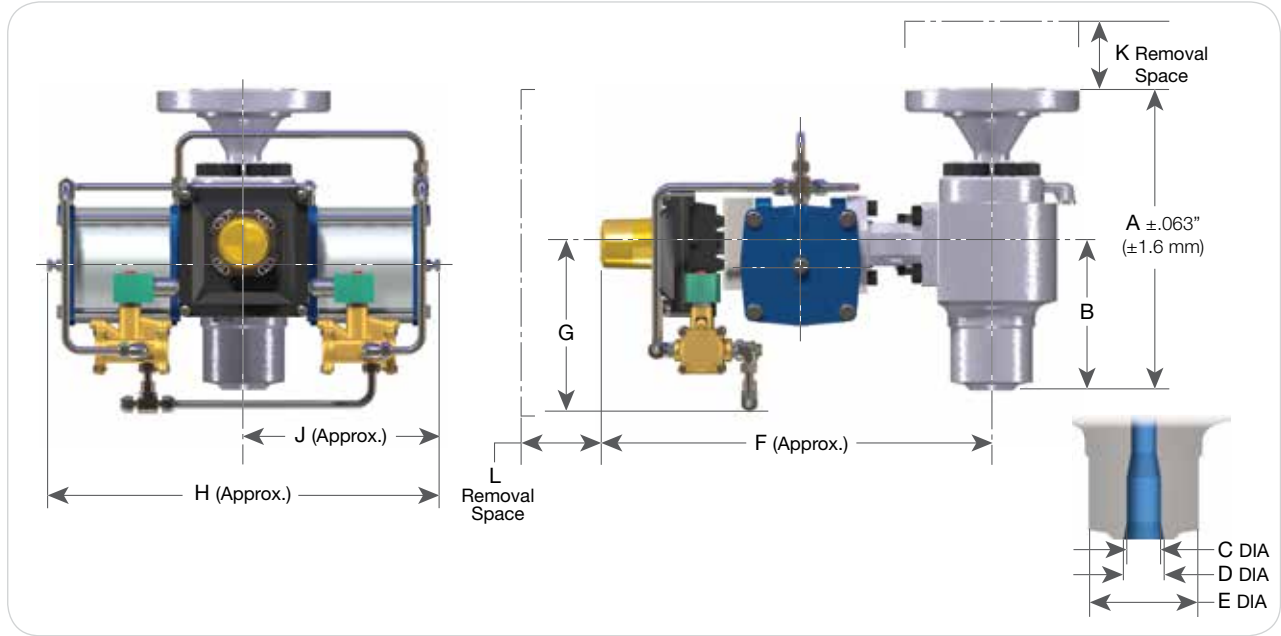

3537W with Ledeen VA123DA Actuator

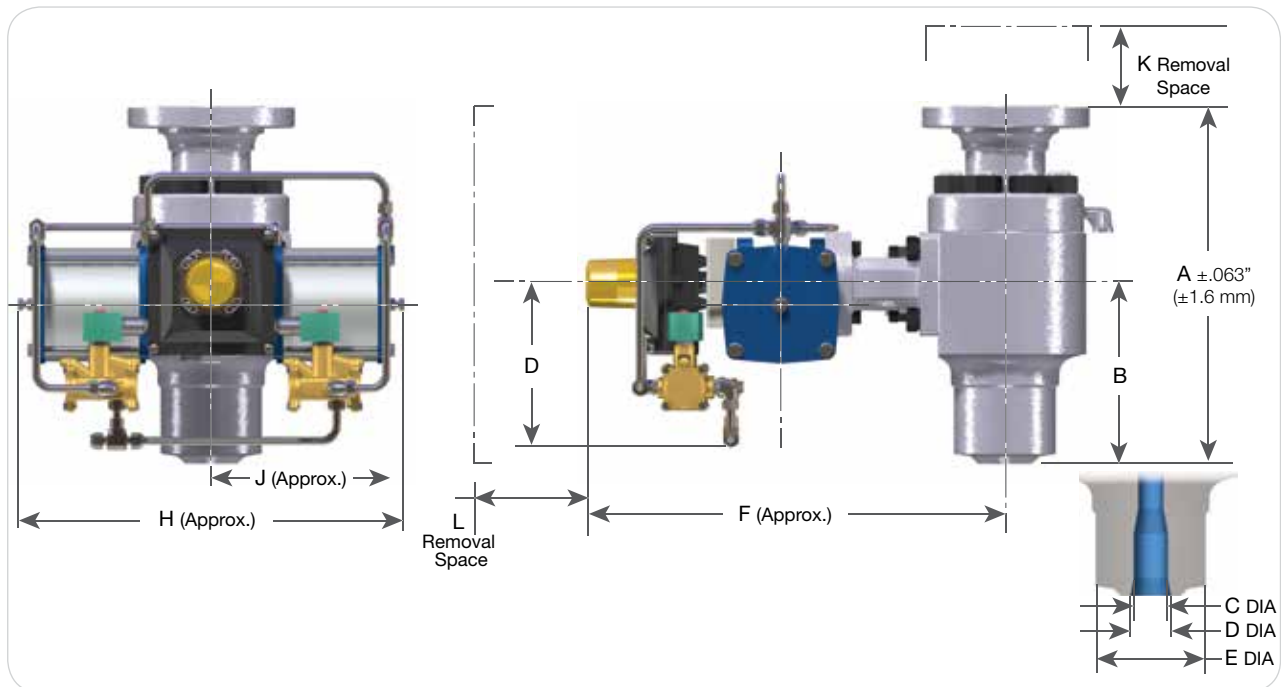

Dimensions and Weights

3500 Butt weld x Flange

3537, 3538 and 3547W with Ledeen GS620 and GS628 Actuators

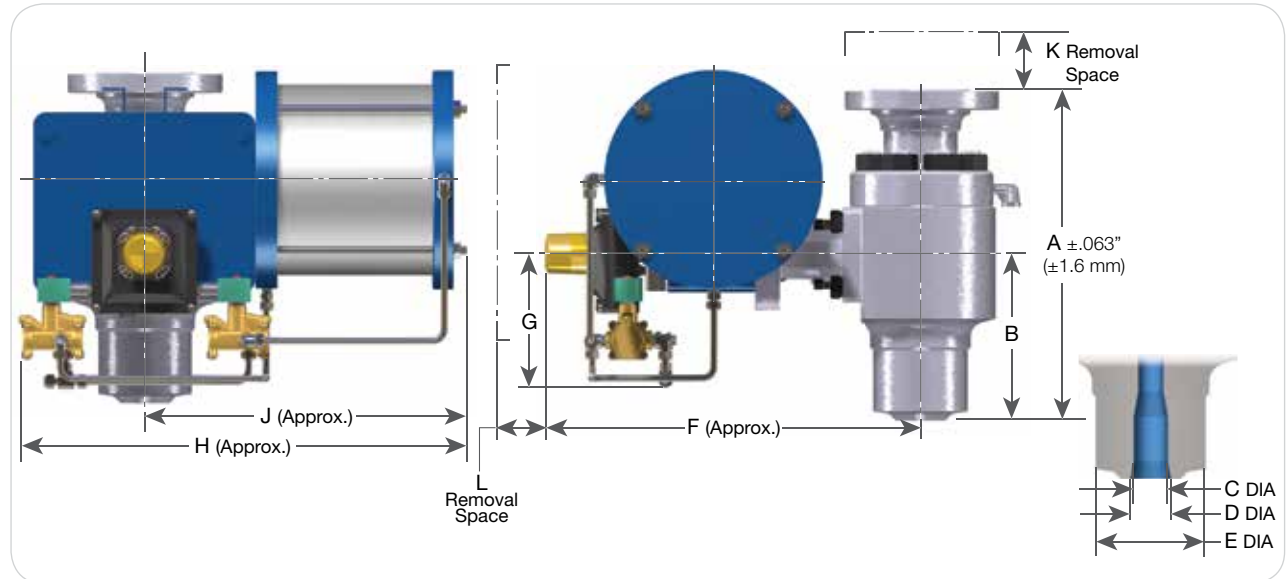

3538W and 3547W with Ledeen SY1032 and SY1043 Actuators

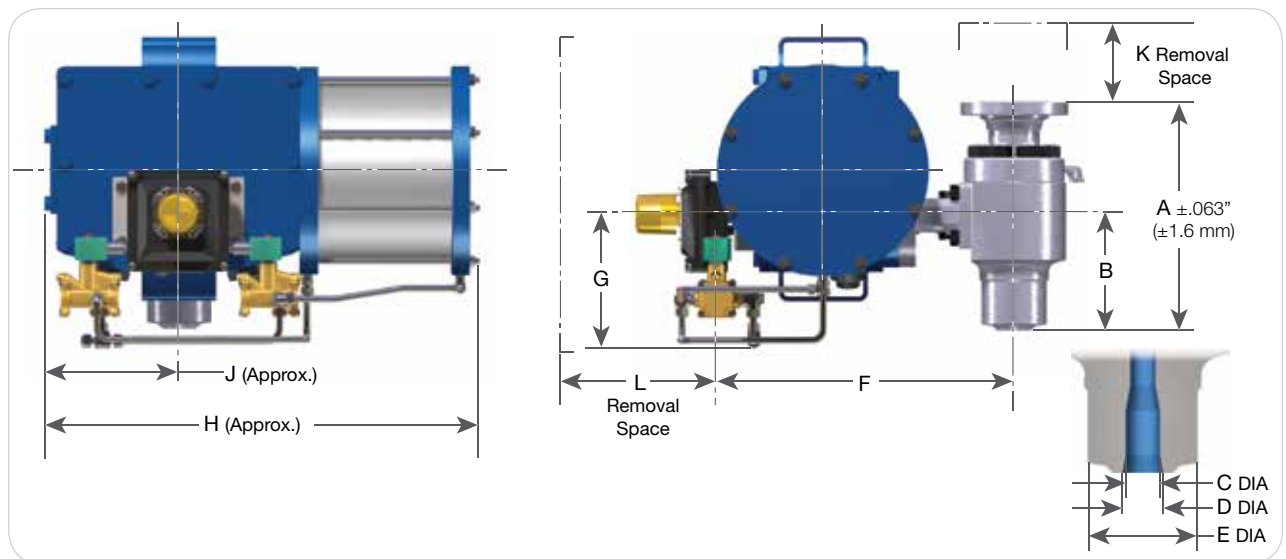

General Dimensions of Optional Accessories (Butt weld)

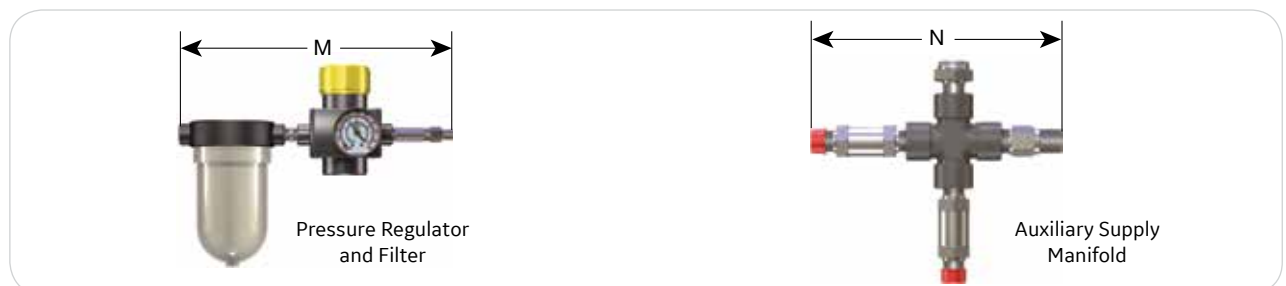

Dimensions and Weights

3500 Butt weld x Flange

Valve Data Butt weld End															
Valve Type	Actuator Model	General Dimensions													
		A		B		C		D		E		F		G	
		in.	mm	in.	mm	in.	mm	in.	mm	in.	mm	in.	mm	in.	mm
3525W	VA123DA	14.00	355.6	6.25	158.8	1.105	28.1	1.50	38.1	4.50	114.3	19.50	495.3	6.38	162.1
3526W	VA123DA	14.00	355.6	6.25	158.8	1.5	38.1	2.00	50.8	4.50	114.3	19.50	495.3	6.38	162.1
3537W	VA123DA	20.25	514.4	9.88	251.0	2.38	60.5	2.75	69.9	6.63	168.4	23.50	596.9	6.38	162.1
	GS620	20.25	514.4	9.88	251.0	2.38	60.5	2.75	69.9	6.63	168.4	22.38	568.5	6.38	162.1
	GS628	20.25	514.4	9.88	251.0	2.38	60.5	2.75	69.9	6.63	168.4	22.38	568.5	6.38	162.1
3547W	GS620	24.63	625.6	9.38	238.3	2.38	60.5	2.75	69.9	6.63	168.4	23.56	598.4	6.38	162.1
	GS628	24.63	625.6	9.38	238.3	2.38	60.5	2.75	69.9	6.63	168.4	23.56	598.4	6.38	162.1
	SY1032	24.63	625.6	9.38	238.3	2.38	60.5	2.75	69.9	6.63	168.4	26.19	665.2	6.38	162.1
	SY1043	24.63	625.6	9.38	238.3	2.38	60.5	2.75	69.9	6.63	168.4	26.19	665.2	6.38	162.1
3538W	GS620	24.63	625.6	9.38	238.3	2.38	60.5	2.75	69.9	6.63	168.4	23.56	598.4	6.38	162.1
	GS628	24.63	625.6	9.38	238.3	2.38	60.5	2.75	69.9	6.63	168.4	23.56	598.4	6.38	162.1
	SY1032	24.63	625.6	9.38	238.3	2.38	60.5	2.75	69.9	6.63	168.4	26.19	665.2	6.38	162.1
	SY1043	24.63	625.6	9.38	238.3	2.38	60.5	2.75	69.9	6.63	168.4	26.19	665.2	6.38	162.1

Valve Data Butt weld End															
Valve Type	Actuator Model	General Dimensions												Approximate Weight	
		H		J		K		L		M		N		lb.	kg
		in.	mm	in.	mm	in.	mm	in.	mm	in.	mm	in.	mm		
3525W	VA123DA	21.63	549.4	10.81	274.6	3.00	76.2	5.00	127.0	7.50	190.5	7.00	177.8	212	96.16
3526W	VA123DA	21.63	549.4	10.81	274.6	3.00	76.2	5.00	127.0	7.50	190.5	7.00	177.8	212	96.16
3537W	VA123DA	21.63	549.4	10.81	274.6	4.50	114.3	7.50	190.5	7.50	190.5	7.00	177.8	370	167.83
	GS620	27.31	693.7	19.56	496.8	4.50	114.3	7.50	190.5	7.50	190.5	7.00	177.8	520	235.87
	GS628	27.31	693.7	19.56	496.8	4.50	114.3	7.50	190.5	7.50	190.5	7.00	177.8	546	247.66
3547W	GS620	27.31	693.7	19.56	496.8	6.00	152.4	10.00	254.0	7.50	190.5	7.00	177.8	520	235.87
	GS628	27.31	693.7	19.56	496.8	6.00	152.4	10.00	254.0	7.50	190.5	7.00	177.8	575	260.82
	SY1032	31.50	800.1	22.50	571.5	6.00	152.4	10.00	254.0	7.50	190.5	8.50	215.9	807	366.05
	SY1043	31.50	800.1	22.50	571.5	6.00	152.4	10.00	254.0	7.50	190.5	8.50	215.9	973	441.35
3538W	GS620	27.31	693.7	19.56	496.8	6.00	152.4	10.00	254.0	7.50	190.5	7.00	177.8	520	235.87
	GS628	27.31	693.7	19.56	496.8	6.00	152.4	10.00	254.0	7.50	190.5	7.00	177.8	575	260.82
	SY1032	31.50	800.1	22.50	571.5	6.00	152.4	10.00	254.0	7.50	190.5	8.50	215.9	807	366.05
	SY1043	31.50	800.1	22.50	571.5	6.00	152.4	10.00	254.0	7.50	190.5	8.50	215.9	973	441.35

Pressure/Temperature

3500 Flanged End

Pressure/Temperature Limit Flanged End					
Valve Types: 3515, 3516, 3517, 3525, 3526, 3527					
Applicable Base Material: ASME SA217 WC9					
Temperature (F)		Pressure (psig)			
		1500# Pressure Class		2500# Pressure Class	
°F	°C	psig	barg	psig	barg
800	782.2	2000	137.89	2500	172.36
850	832.2	2000	137.89	2500	172.36
900	882.2	2000	137.89	2500	172.36
920	902.2	2000	137.89	2500	172.36
940	922.2	1993	137.41	2500	172.36
960	942.2	1811	124.86	2500	172.36
980	962.2	1573	108.45	2500	172.36
1000	982.2	1335	92.04	2230	153.75
1020	1002.2	1151	79.35	1920	132.37
1050	1032.2	875	60.32	1455	100.31
1100	1082.2	550	37.92	915	63.08
1150	1132.2	345	23.78	570	39.30

3500 Butt weld End

Pressure/Temperature Limit Butt weld End					
Valve Types: 3525W, 3526W					
Applicable Base Material: ASME SA182 F22 and SA182 F91					
Temperature (F)		Pressure (psig)			
		F22		F91	
°F	°C	psig	barg	psig	barg
900	882.2	2500	172.36	2500	172.36
920	902.2	2500	172.36	2500	172.36
940	922.2	2500	172.36	2500	172.36
960	942.2	2500	172.36	2500	172.36
980	962.2	2500	172.36	2500	172.36
1000	982.2	2500	172.36	2500	172.36
1020	1002.2	2500	172.36	2500	172.36
1050	1032.2	2197	151.47	2500	172.36
1100	1082.2	1381	95.21	2500	172.36
1150	1132.2	862	59.43	2500	172.36

Pressure/Temperature

3500 Butt weld End

Pressure/Temperature Limit Butt weld End					
Valve Types: 3537W, 3538W					
Applicable Base Material: ASME SA182 F22 and SA182 F91					
Temperature (F)		Pressure (psig)			
		F22		F91	
°F	°C	psig	barg	psig	barg
900	882.2	3000	206.84	3000	206.84
920	902.2	3000	206.84	3000	206.84
940	922.2	3000	206.84	3000	206.84
960	942.2	3000	206.84	3000	206.84
980	962.2	3000	206.84	3000	206.84
1000	982.2	3000	206.84	3000	206.84
1020	1002.2	3000	206.84	3000	206.84
1050	1032.2	2637	181.81	3000	206.84
1100	1082.2	1656	114.17	3000	206.84
1150	1132.2	1034	71.29	3000	206.84

Pressure/Temperature Limit Butt weld End					
Valve Types: 3547W					
Applicable Base Material: ASME SA182 F22 and SA182 F91					
Temperature (F)		Pressure (psig)			
		F22		F91	
°F	°C	psig	barg	psig	barg
900	882.2	4500	310.26	4500	310.26
920	902.2	4500	310.26	4500	310.26
940	922.2	4500	310.26	4500	310.26
960	942.2	4500	310.26	4500	310.26
980	962.2	4500	310.26	4500	310.26
1000	982.2	4500	310.26	4500	310.26
1020	1002.2	4500	310.26	4500	310.26
1030	1012.2	4500	310.26	4500	310.26
1040	1022.2	4493	309.78	4500	310.26
1050	1032.2	4063	280.13	4500	310.26
1100	1082.2	2546	175.54	4500	310.26
1150	1132.2	1592	109.76	4500	310.26

Orifice Capacities

System Components

The Consolidated 3500 Series EBV is supplied with standard orifice bores. Capacity tables specify the relieving capabilities of these valves with a maximum or standard orifice size. Orifice sizes smaller than standard may be specified to reduce the capacity to lower values than those stated in the capacity tables.

BHGE recommends that the 3500 EBV be sized as an integral part of the total safety valve system to help ensure that the safety valves operate properly and within ASME requirements for set pressure, lift and blow down.

Note: Total system sizing is not included in the following examples. For total system sizing, refer to Safety Valve Product Information Sheet SV/PI-53, or submit the total information required in the "Ordering Information" section to the factory for review.

Example 1

For a new installation with no piping connections specified:

Set Pressure: 2000 psig (137.89 barg)

Required Capacity: 90,000 pph steam at
1000°F and 3 percent over pressure
Non-ASME Section I rated

Step 1

Determine the saturated capacity and full bore size from the appropriate capacity tables on pages 17 through 30. The selected capacity should be greater than or equal to the required capacity.

If not, select the next larger bore size.

Page 3500.18 "Capacity Tables"

1.750 Bore, 2.5-inch (63.5 mm), 35_7

Capacity at 2,000 psig (137.89 barg) = 258,364 pph saturated

258,364 pph \geq 90,000 pph

Select #7 orifice designation

Step 2

Correct for superheated steam temperatures using the "Superheat Correction Factors" on page 33. Convert the set pressure from psig to psia flowing pressure, then determine the superheat correction factor at the relieving temperature (interpolate when necessary). Multiply the saturated steam capacity calculated in Step 1 by the selected correction factor. The calculated capacity should be greater than or equal to the required capacity. If not, repeat Step 1 and select a larger bore size.

"Superheat Correction Factors"

PSIA = (2,000 psig (137.89 barg) x 1.03) + 14.7 = 2,074 psia

2,074.7 psia at 1,000°F = 0.760 SHCF

0.760 x 258,364 pph = 196,396 pph

196,396 pph \geq 90,000 pph

Step 3

Determine any required reduction in capacity or bore size. Calculate the percentage of required capacity versus the full capacity as described in Steps 1 and 2. Using the section titled "Reduced Bore Selection and Capacity Factor" on page 30, refer to the table that corresponds to the full bore size selected. From the column marked "Relation to 100 percent," select the percentage that is equal to or greater than the calculated percentage. Multiply the full capacity corrected for temperature by the capacity factor selected. The reduced bore capacity should be greater than or equal to the required capacity.

Required capacity/full bore capacity at 1,000°F

90,000 pph/196,396 pph = 45.8 percent

Page 3500.23 "Reduced Bore Selection and Capacity Factor"

1.750 Bore, 2.5-inch (63.5 mm), 3517, 3527 3537 and 3547

46 percent \geq 45.8 percent.

46 x 196,396 pph = 90,342 pph

90,342 pph \geq 90,000 pph

Select 1-3/16 Reduced Bore

Step 4

Verify "Pressure Class" using page 13 for "Maximum Pressure and Temperature" for 3500 EBV.

2,000 psig (137.89 barg) at 1,000°F, 1.750 Bore (#7 designation)

2.5" (63.5 mm) 3527F, 2170 psig (149.62 barg) > 2000 psig (137.89

barg) or 2.5" (63.5 mm) 3537W, 3000 psig (206.84 barg) > 2000

psig (137.89 barg)

Step 5

Review section titled "Scope of Design" on Page 3500.9.

Replace With

3527F = 2,500 Class, 2.5-inch (63.5 mm) 2,500 Class Flange x 4"

(101.60 mm) 300 Class Flange

Reduced bore from 1.750 to 1-3/16

Set 2,000 psig 90,342 pph at 1,000°F

or 3537W = 3,000 Class, 2.5" (63.5 mm) Buttweld x 4-inch (101.60 mm) 300 Class Flange

Reduced bore from 1.750 to 1-3/16

Set 2,000 psig (137.89 barg) 90,342 pph at 1,000°F

Orifice Capacities

Example 2

For replacement valve selection when valve type and/or a serial number is provided:

Replace a 2.5-inch (63.50 mm) 2533VX (15) - XI S/N BV03275
Set 1,200 psig (82.74 barg)

Required capacity is 100,856 pph at 900°F
3 percent overpressure 100 percent of Actual Capacity –
Non-ASME Section I Rated
Full 1.625-inch (41.28 mm) bore, 1,500 Class Inlet Flange

Step 1

Review the section titled “Scope of Design” on page 3500.9.

3517F, 1,500 Class, Bore 1.750, 2.5-inch (63.5 mm)
1,500 Class Flange x 4-inch (101.60 mm) 300 Class Flange

Step 2

Verify “Maximum Pressure Temperature Limits” on page 13.
The maximum pressure for valve selected at a given temperature must be greater than or equal to the set pressure of the valve being replaced.

Page 14 for 3,517F at 900°F (482.2°C) = 2,245 psig (154.79 barg)
2,245 psig (154.79 barg) ≥ 1,200 psig (82.74 barg)

Step 3

Verify capacity in section titled “Capacity Tables” on pages 17 through 30.

Page 18 1.750 bore, #7 orifice designation, 2.5-inch (63.50 mm), 3,517 at 3 percent over pressure 100 percent of actual capacity - non-ASME Section I rated. At 1,200 psig (82.74 barg) set pressure = 150,834 pph saturated steam capacity.
150,834 pph ≥ 100,856 pph

Step 4

Correct for superheated steam temperatures using the “Superheat Correction Factors” on page 33. Convert psig to psia. Select the correction factor for set pressure psia at the required relieving temperature and multiply the saturated steam capacity calculated in Step 3 by the correction factor. Verify it is greater than or equal to the required capacity.

1,200 psig (82.74 barg) = (1,200 x 1.03) + 14.7 = 1,250 psia
1,250 psia at 900°F (482.2°C) = .804 SHCF
.804 x 150,834 pph = 121,270 pph at 900°F (482.2°C)
121,270 pph ≥ 100,856 pph

Step 5

Select reduced bore if required. Calculate the percentage of required capacity versus the full bore capacity as calculated in Step 4. Using the section titled “Reduced Bore Selection and Capacity Factor” on page 30, refer to the table that corresponds to the 1.750 full bore size selected. From the column marked “Relation to 100 percent,” select the percentage that is equal to or greater than the calculated percentage. Multiply the full capacity corrected for temperature by the capacity factor selected. The reduced bore capacity should be greater than or equal to the required capacity.

Required capacity/full bore capacity at 900°F (482.2°C)
100,856 pph/121,270 pph = 84 percent
Select 1.625-inch (41.28 mm), 86.2 percent ≥ 84 percent
Use 3517F with 1.625-inch (41.28 mm) reduced bore
121,270 pph (full bore capacity) x .862 = 104,534 pph
104,534 pph ≥ 100,856 pph

Replace with:

2.5-inch (63.50 mm) 3517 F-1-X1, 2.5-inch (63.50 mm)
1,500 Class Flange x 4-inch (101.60 mm) 300 Class Flange
with 1.625 (41.28 mm) Reduced Bore
Set 1,200 psig (82.74 barg)

Orifice Capacities

W= Slope x P for P ≤ 1580 psia
 P = (1.03 x set pressure) + 14.7

$$W = \text{Slope} \times P \times \left[\frac{0.1906 \times P - 1000}{0.2292 \times P - 1061} \right] \quad \text{For } P > 1580 \text{ psia}$$

Valve Capacity - Non-ASME Code Rated, for Saturated Steam. The saturated steam table for Non-ASME Section I is based at 3 percent overpressure or 2 psig (0.14 barg), whichever is greater, showing 100 percent actual capacity.

Slope		in.	mm	in.	mm	in.	mm	in.	mm
		29.90	759.5	37.80	960.1	120.60	3063.2	157.40	3998.0
Flow Area		in ²	cm ²	in ²	cm ²	in ²	cm ²	in ²	cm ²
		0.875	5.645	1.000	6.452	1.750	11.290	2.000	12.903
Designation		35X5		35X6		35X7		35X8	
		Set Pressure ¹		Orifice Capacity					
psig	barg	lb/hr	kg/hr	lb/hr	kg/hr	lb/hr	kg/hr	lb/hr	kg/hr
100	6.89	3519	242.60	4449	306.70	14194	978.60	18525	1277.20
110	7.58	3827	263.80	4838	333.50	15436	1064.20	20147	1389.00
120	8.27	4135	285.00	5227	360.30	16678	1149.90	21768	1500.80
130	8.96	4443	306.30	5617	387.20	17921	1235.60	23389	1612.60
140	9.65	4751	327.50	6006	414.00	19163	1321.20	25010	1724.30
150	10.34	5059	348.80	6395	440.90	20405	1406.80	26632	1836.20
160	11.03	5367	370.00	6785	467.80	21647	1492.50	28253	1947.90
170	11.72	5675	391.20	7174	494.60	22889	1578.10	29874	2059.70
180	12.41	5982	412.40	7563	521.40	24132	1663.80	31495	2171.50
190	13.10	6290	433.60	7953	548.30	25374	1749.40	33116	2283.20
200	13.78	6598	454.90	8342	575.10	26616	1835.10	34738	2395.10
210	14.47	6906	476.10	8731	601.90	27858	1920.70	36359	2506.80
220	15.16	7214	497.30	9121	628.80	29100	2006.30	37980	2618.60
230	15.85	7522	518.60	9510	655.60	30342	2092.00	39601	2730.30
240	16.54	7830	539.80	9899	682.50	31585	2177.70	41223	2842.20
250	17.23	8138	561.00	10289	709.40	32827	2263.30	42844	2953.90
260	17.92	8446	582.30	10678	736.20	34069	2348.90	44465	3065.70
270	18.61	8754	603.50	11067	763.00	35311	2434.60	46086	3177.50
280	19.30	9062	624.80	11457	789.90	36553	2520.20	47707	3289.20
290	19.99	9370	646.00	11846	816.70	37796	2605.90	49329	3401.10
300	20.68	9678	667.20	12235	843.50	39038	2691.50	50950	3512.80
310	21.37	9986	688.50	12625	870.40	40280	2777.20	52571	3624.60
320	22.06	10294	709.70	13014	897.20	41522	2862.80	54192	3736.40
330	22.75	10602	730.90	13403	924.10	42764	2948.40	55813	3848.20
340	23.44	10910	752.20	13793	950.90	44006	3034.10	57435	3960.00
350	24.13	11218	773.40	14182	977.80	45249	3119.80	59056	4071.70
360	24.82	11526	794.60	14571	1004.60	46491	3205.40	60677	4183.50
370	25.51	11834	815.90	14961	1031.50	47733	3291.00	62298	4295.20
380	26.20	12142	837.10	15350	1058.30	48975	3376.70	63920	4407.10
390	26.88	12450	858.30	15739	1085.10	50217	3462.30	65541	4518.80
400	27.57	12758	879.60	16129	1112.00	51460	3548.00	67162	4630.60
410	28.26	13066	900.80	16518	1138.80	52702	3633.60	68783	4742.40
420	28.95	13374	922.10	16907	1165.60	53944	3719.30	70405	4854.20
430	29.64	13682	943.30	17297	1192.50	55186	3804.90	72026	4966.00
440	30.33	13990	964.50	17686	1219.40	56428	3890.50	73647	5077.70
450	31.02	14298	985.80	18075	1246.20	57670	3976.20	75268	5189.50
460	31.71	14606	1007.00	18465	1273.10	58913	4061.90	76889	5301.30
470	32.40	14914	1028.20	18854	1299.90	60155	4147.50	78511	5413.10
480	33.09	15222	1049.50	19243	1326.70	61397	4233.10	80132	5524.90
490	33.78	15530	1070.70	19633	1353.60	62639	4318.80	81753	5636.60
500	34.47	15838	1091.90	20022	1380.40	63881	4404.40	83374	5748.40
510	35.16	16146	1113.20	20412	1407.30	65124	4490.10	84996	5860.20
520	35.85	16453	1134.30	20801	1434.10	66366	4575.70	86617	5972.00
530	36.54	16761	1155.60	21190	1460.90	67608	4661.40	88238	6083.70
540	37.23	17069	1176.80	21580	1487.80	68850	4747.00	89859	6195.50
550	37.92	17377	1198.10	21969	1514.70	70092	4832.60	91480	6307.30
560	38.61	17685	1219.30	22358	1541.50	71334	4918.30	93102	6419.10
570	39.30	17993	1240.50	22748	1568.40	72577	5004.00	94723	6530.90
580	39.98	18301	1261.80	23137	1595.20	73819	5089.60	96344	6642.60
590	40.67	18609	1283.00	23526	1622.00	75061	5175.20	97965	6754.40
600	41.36	18917	1304.20	23916	1648.90	76303	5260.90	99586	6866.20
610	42.05	19225	1325.50	24305	1675.70	77545	5346.50	101208	6978.00
620	42.74	19533	1346.70	24694	1702.50	78787	5432.10	102829	7089.80
630	43.43	19841	1367.90	25084	1729.40	80030	5517.80	104450	7201.50
640	44.12	20149	1389.20	25473	1756.30	81272	5603.50	106071	7313.30
650	44.81	20457	1410.40	25862	1783.10	82514	5689.10	107693	7425.10
660	45.50	20765	1431.60	26252	1810.00	83756	5774.70	109314	7536.90
670	46.19	21073	1452.90	26641	1836.80	84998	5860.40	110935	7648.60
680	46.88	21381	1474.10	27030	1863.60	86241	5946.10	112556	7760.40
690	47.57	21689	1495.40	27420	1890.50	87483	6031.70	114177	7872.20

Note:

- The minimum set pressure is 50 psig (3.45 barg). For set pressures 50 psig (3.45 barg) to 99 psig (6.83 barg) contact the factory.

Orifice Capacities

W = Slope x P for P ≤ 1580 psia
 P = (1.03 x set pressure) + 14.7

W = Slope x P x $\left[\frac{0.1906 \times P - 1000}{0.2292 \times P - 1061} \right]$ For P > 1580 psia

Valve Capacity - Non-ASME Code Rated, for Saturated Steam. The saturated steam table for Non-ASME Section I is based at 3 percent overpressure or 2 psig (0.14 barg), whichever is greater, showing 100 percent actual capacity.

Slope		in.	mm	in.	mm	in.	mm	in.	mm
		29.90	759.5	37.80	960.1	120.60	3063.2	157.40	3998.0
Flow Area		in ²	cm ²	in ²	cm ²	in ²	cm ²	in ²	cm ²
		0.875	5.645	1.000	6.452	1.750	11.290	2.000	12.903
Designation		35X5		35X6		35X7		35X8	
Set Pressure ¹		Orifice Capacity							
psig	barg	lb/hr	kg/hr	lb/hr	kg/hr	lb/hr	kg/hr	lb/hr	kg/hr
700	48.26	21997	1516.60	27809	1917.30	88725	6117.30	115799	7984.00
710	48.95	22305	1537.80	28198	1944.10	89967	6203.00	117420	8095.80
720	49.64	22613	1559.10	28588	1971.00	91209	6288.60	119041	8207.50
730	50.33	22921	1580.30	28977	1997.80	92451	6374.20	120662	8319.30
740	51.02	23229	1601.50	29366	2024.70	93694	6459.90	122284	8431.10
750	51.71	23537	1622.80	29756	2051.60	94936	6545.60	123905	8542.90
760	52.40	23845	1644.00	30145	2078.40	96178	6631.20	125526	8654.70
770	53.08	24153	1665.20	30534	2105.20	97420	6716.80	127147	8766.40
780	53.77	24461	1686.50	30924	2132.10	98662	6802.50	128768	8878.20
790	54.46	24769	1707.70	31313	2158.90	99905	6888.20	130390	8990.00
800	55.15	25077	1728.90	31702	2185.70	101147	6973.80	132011	9101.80
810	55.84	25385	1750.20	32092	2212.60	102389	7059.40	133632	9213.60
820	56.53	25693	1771.40	32481	2239.40	103631	7145.10	135253	9325.30
830	57.22	26001	1792.70	32870	2266.30	104873	7230.70	136875	9437.10
840	57.91	26309	1813.90	33260	2293.10	106115	7316.30	138496	9548.90
850	58.60	26616	1835.10	33649	2320.00	107358	7402.00	140117	9660.70
860	59.29	26924	1856.30	34038	2346.80	108600	7487.70	141738	9772.40
870	59.98	27232	1877.50	34428	2373.70	109842	7573.30	143359	9884.20
880	60.67	27540	1898.80	34817	2400.50	111084	7658.90	144981	9996.00
890	61.36	27848	1920.00	35206	2427.30	112326	7744.60	146602	10107.80
900	62.05	28156	1941.20	35596	2454.20	113569	7830.30	148223	10219.60
910	62.74	28464	1962.50	35985	2481.00	114811	7915.90	149844	10331.30
920	63.43	28772	1983.70	36374	2507.80	116053	8001.50	151466	10443.20
930	64.12	29080	2004.90	36764	2534.70	117295	8087.20	153087	10554.90
940	64.81	29388	2026.20	37153	2561.60	118537	8172.80	154708	10666.70
950	65.50	29696	2047.40	37542	2588.40	119779	8258.40	156329	10778.50
960	66.18	30004	2068.70	37932	2615.30	121022	8344.10	157950	10890.20
970	66.87	30312	2089.90	38321	2642.10	122264	8429.80	159572	11002.00
980	67.56	30620	2111.10	38710	2668.90	123506	8515.40	161193	11113.80
990	68.25	30928	2132.40	39100	2695.80	124748	8601.00	162814	11225.60
1000	68.94	31236	2153.60	39489	2722.60	125990	8686.70	164435	11337.30
1010	69.63	31544	2174.80	39879	2749.50	127233	8772.40	166057	11449.20
1020	70.32	31852	2196.10	40268	2776.30	128475	8858.00	167678	11560.90
1030	71.01	32160	2217.30	40657	2803.20	129717	8943.60	169299	11672.70
1040	71.70	32468	2238.50	41047	2830.00	130959	9029.30	170920	11784.50
1050	72.39	32776	2259.80	41436	2856.90	132201	9114.90	172541	11896.20
1060	73.08	33084	2281.00	41825	2883.70	133443	9200.50	174163	12008.00
1070	73.77	33392	2302.20	42215	2910.60	134686	9286.20	175784	12119.80
1080	74.46	33700	2323.50	42604	2937.40	135928	9371.90	177405	12231.60
1090	75.15	34008	2344.70	42993	2964.20	137170	9457.50	179026	12343.40
1100	75.84	34316	2366.00	43383	2991.10	138412	9543.10	180647	12455.10
1110	76.53	34624	2387.20	43772	3017.90	139654	9628.80	182269	12566.90
1120	77.22	34932	2408.40	44161	3044.70	140896	9714.40	183890	12678.70
1130	77.91	35240	2429.70	44551	3071.60	142139	9800.10	185511	12790.50
1140	78.60	35548	2450.90	44940	3098.50	143381	9885.70	187132	12902.20
1150	79.29	35856	2472.10	45329	3125.30	144623	9971.40	188754	13014.00
1160	79.98	36164	2493.40	45719	3152.20	145865	10057.00	190375	13125.80
1170	80.67	36472	2514.60	46108	3179.00	147107	10142.60	191996	13237.60
1180	81.36	36779	2535.80	46497	3205.80	148350	10228.30	193617	13349.40
1190	82.05	37087	2557.00	46887	3232.70	149592	10314.00	195238	13461.10
1200	82.74	37395	2578.20	47276	3259.50	150834	10399.60	196860	13572.90
1210	83.43	37703	2599.50	47665	3286.30	152076	10485.20	198481	13684.70
1220	84.12	38011	2620.70	48055	3313.20	153318	10570.90	200102	13796.50
1230	84.81	38319	2642.00	48444	3340.00	154560	10656.50	201723	13908.30
1240	85.50	38627	2663.20	48833	3366.90	155803	10742.20	203344	14020.10
1250	86.19	38935	2684.40	49223	3393.80	157045	10827.80	204966	14131.90
1260	86.88	39243	2705.70	49612	3420.60	158287	10913.50	206587	14243.60
1270	87.57	39551	2726.90	50001	3447.40	159529	10999.10	208208	14355.40
1280	88.26	39859	2748.10	50391	3474.30	160771	11084.70	209829	14467.10
1290	88.95	40167	2769.40	50780	3501.10	162014	11170.40	211451	14578.90

Note:

1. The minimum set pressure is 50 psig (3.45 barg). For set pressures 50 psig (3.45 barg) to 99 psig (6.83 barg) contact the factory.

Orifice Capacities

W = Slope x P for P ≤ 1580 psia
 P = (1.03 x set pressure) + 14.7

W = Slope x P x $\left[\frac{0.1906 \times P - 1000}{0.2292 \times P - 1061} \right]$ For P > 1580 psia

Valve Capacity - Non-ASME Code Rated, for Saturated Steam. The saturated steam table for Non-ASME Section I is based at 3 percent overpressure or 2 psig (0.14 barg), whichever is greater, showing 100 percent actual capacity.

Slope		in.	mm	in.	mm	in.	mm	in.	mm
		29.90	759.5	37.80	960.1	120.60	3063.2	157.40	3998.0
Flow Area		in ²	cm ²	in ²	cm ²	in ²	cm ²	in ²	cm ²
		0.875	5.645	1.000	6.452	1.750	11.290	2.000	12.903
Designation		35X5		35X6		35X7		35X8	
Set Pressure ¹		Orifice Capacity							
psig	barg	lb/hr	kg/hr	lb/hr	kg/hr	lb/hr	kg/hr	lb/hr	kg/hr
1300	89.63	40475	2790.60	51169	3527.90	163256	11256.10	213072	14690.70
1310	90.32	40783	2811.80	51559	3554.80	164498	11341.70	214693	14802.50
1320	91.01	41091	2833.10	51948	3581.60	165740	11427.30	216314	14914.30
1330	91.70	41399	2854.30	52337	3608.50	166982	11513.00	217936	15026.10
1340	92.38	41707	2875.50	52727	3635.30	168224	11598.60	219557	15137.90
1350	93.07	42015	2896.80	53116	3662.20	169467	11684.30	221178	15249.60
1360	93.76	42323	2918.00	53505	3689.00	170709	11769.90	222799	15361.40
1370	94.45	42631	2939.30	53895	3715.90	171951	11855.60	224420	15473.20
1380	95.14	42939	2960.50	54284	3742.70	173193	11941.20	226042	15585.00
1390	95.83	43247	2981.70	54673	3769.50	174435	12026.80	227663	15696.80
1400	96.52	43555	3003.00	55063	3796.40	175678	12112.50	229284	15808.50
1410	97.21	43863	3024.20	55452	3823.20	176920	12198.20	230905	15920.30
1420	97.90	44171	3045.40	55841	3850.10	178162	12283.80	232527	16032.10
1430	98.59	44479	3066.70	56231	3876.90	179404	12369.40	234148	16143.90
1440	99.28	44787	3087.90	56620	3903.80	180646	12455.10	235769	16255.60
1450	99.97	45095	3109.10	57009	3930.60	181888	12540.70	237390	16367.40
1460	100.66	45403	3130.40	57399	3957.50	183131	12626.40	239011	16479.20
1470	101.35	45711	3151.60	57788	3984.30	184373	12712.00	240633	16591.00
1480	102.04	46019	3172.80	58177	4011.10	185615	12797.70	242254	16702.80
1490	102.73	46327	3194.10	58567	4038.00	186857	12883.30	243875	16814.50
1500	103.42	46635	3215.30	58956	4064.80	188099	12968.90	245496	16926.30
1510	104.11	46943	3236.60	59346	4091.70	189342	13054.60	247118	17038.10
1520	104.80	47251	3257.70	59735	4118.50	190584	13140.30	248739	17149.90
1530	105.49	47559	3278.90	60125	4145.40	191827	13226.00	250360	17261.70
1540	106.18	47867	3300.00	60514	4172.20	193070	13311.70	251981	17373.50
1550	106.87	48175	3321.20	60904	4200.00	194312	13397.40	253603	17485.30
1560	107.56	48483	3342.30	61293	4227.80	195555	13483.10	255224	17597.10
1570	108.25	48791	3363.50	61683	4255.60	196797	13568.80	256846	17708.90
1580	108.94	49100	3384.60	62072	4283.40	198040	13654.50	258467	17820.70
1590	109.63	49408	3405.80	62462	4311.20	199282	13740.20	260089	17932.50
1600	110.32	49717	3426.90	62851	4339.00	200525	13825.90	261710	18044.30
1610	111.01	50025	3448.00	63241	4366.80	201767	13911.60	263332	18156.10
1620	111.70	50334	3469.10	63630	4394.60	203010	14000.00	264953	18267.90
1630	112.39	50642	3490.20	64020	4422.40	204252	14086.30	266575	18379.70
1640	113.08	50951	3511.30	64409	4450.20	205495	14172.60	268196	18491.50
1650	113.77	51259	3532.40	64800	4478.00	206737	14258.90	269818	18603.30
1660	114.46	51568	3553.50	65189	4505.80	207980	14345.20	271439	18715.10
1670	115.15	51876	3574.60	65579	4533.60	209222	14431.50	273061	18826.90
1680	115.84	52185	3595.70	65968	4561.40	210465	14517.80	274682	18938.70
1690	116.53	52493	3616.80	66358	4589.20	211707	14604.10	276304	19050.50
1700	117.22	52802	3637.90	66747	4617.00	212950	14690.40	277925	19162.30
1710	117.91	53110	3659.00	67137	4644.80	214192	14776.70	279547	19274.10
1720	118.60	53419	3680.10	67526	4672.60	215435	14863.00	281168	19385.90
1730	119.29	53727	3701.20	67916	4700.40	216677	14949.30	282790	19497.70
1740	119.98	54036	3722.30	68305	4728.20	217920	15035.60	284411	19609.50
1750	120.67	54344	3743.40	68695	4756.00	219162	15121.90	286033	19721.30
1760	121.36	54653	3764.50	69084	4783.80	220405	15208.20	287654	19833.10
1770	122.05	54961	3785.60	69474	4811.60	221647	15294.50	289276	19944.90
1780	122.74	55270	3806.70	69863	4839.40	222890	15380.80	290897	20056.70
1790	123.43	55578	3827.80	70253	4867.20	224132	15467.10	292519	20168.50
1800	124.12	55887	3848.90	70642	4895.00	225375	15553.40	294140	20280.30
1810	124.81	56195	3870.00	71032	4922.80	226617	15639.70	295762	20392.10
1820	125.50	56504	3891.10	71421	4950.60	227860	15726.00	297383	20503.90
1830	126.19	56812	3912.20	71811	4978.40	229102	15812.30	299005	20615.70
1840	126.88	57121	3933.30	72200	5006.20	230345	15898.60	300626	20727.50
1850	127.57	57429	3954.40	72590	5034.00	231587	15984.90	302248	20839.30
1860	128.26	57738	3975.50	72979	5061.80	232830	16071.20	303869	20951.10
1870	128.95	58046	3996.60	73369	5089.60	234072	16157.50	305491	21062.90
1880	129.64	58355	4017.70	73758	5117.40	235315	16243.80	307112	21174.70
1890	130.33	58663	4038.80	74148	5145.20	236557	16330.10	308734	21286.50

Note:

- The minimum set pressure is 50 psig (3.45 barg). For set pressures 50 psig (3.45 barg) to 99 psig (6.83 barg) contact the factory.

Orifice Capacities

W = Slope x P for P ≤ 1580 psia
 P = (1.03 x set pressure) + 14.7

W = Slope x P x $\left[\frac{0.1906 \times P - 1000}{0.2292 \times P - 1061} \right]$ For P > 1580 psia

Valve Capacity - Non-ASME Code Rated, for Saturated Steam. The saturated steam table for Non-ASME Section I is based at 3 percent overpressure or 2 psig (0.14 barg), whichever is greater, showing 100 percent actual capacity.

Slope		in.	mm	in.	mm	in.	mm	in.	mm
		29.90	759.5	37.80	960.1	120.60	3063.2	157.40	3998.0
Flow Area		in ²	cm ²	in ²	cm ²	in ²	cm ²	in ²	cm ²
		0.875	5.645	1.000	6.452	1.750	11.290	2.000	12.903
Designation		35X5		35X6		35X7		35X8	
Set Pressure ¹		Orifice Capacity							
psig	barg	lb/hr	kg/hr	lb/hr	kg/hr	lb/hr	kg/hr	lb/hr	kg/hr
1900	131.00	60416	4165.50	76378	5266.00	243685	16801.40	318043	21928.20
1910	131.68	60776	4190.30	76834	5297.50	245137	16901.60	319939	22059.00
1920	132.37	61137	4215.20	77290	5328.90	246593	17001.90	321839	22190.00
1930	133.06	61499	4240.20	77747	5360.40	248052	17102.50	323744	22321.30
1940	133.75	61861	4265.10	78206	5392.10	249515	17203.40	325653	22452.90
1950	134.44	62225	4290.20	78665	5423.70	250981	17304.50	327566	22584.80
1960	135.13	62589	4315.30	79126	5455.50	252451	17405.80	329484	22717.10
1970	135.82	62954	4340.50	79588	5487.30	253924	17507.40	331406	22849.60
1980	136.51	63320	4365.70	80050	5519.20	255400	17609.20	333333	22982.50
1990	137.20	63687	4391.00	80514	5551.20	256880	17711.20	335265	23115.70
2000	137.89	64055	4416.40	80979	5583.30	258364	17813.50	337201	23249.10
2010	138.58	64424	4441.80	81446	5615.50	259851	17916.00	339142	23383.00
2020	139.27	64793	4467.30	81913	5647.70	261342	18018.80	341088	23517.10
2030	139.96	65164	4492.80	82381	5679.90	262837	18121.90	343039	23651.70
2040	140.65	65535	4518.40	82851	5712.30	264335	18225.20	344995	23786.50
2050	141.34	65908	4544.10	83322	5744.80	265838	18328.80	346956	23921.70
2060	142.03	66281	4569.90	83794	5777.30	267344	18432.70	348922	24057.30
2070	142.72	66656	4595.70	84267	5810.00	268854	18536.80	350893	24193.20
2080	143.41	67031	4621.60	84742	5842.70	270368	18641.20	352869	24329.40
2090	144.10	67408	4647.60	85218	5875.50	271886	18745.80	354850	24466.00
2100	144.78	67785	4673.60	85695	5908.40	273408	18850.80	356837	24603.00
2110	145.47	68163	4699.60	86173	5941.40	274935	18956.10	358829	24740.30
2120	146.16	68543	4725.80	86653	5974.50	276465	19061.50	360826	24878.00
2130	146.85	68923	4752.00	87134	6007.60	278000	19167.40	362830	25016.20
2140	147.54	69305	4778.40	87616	6040.90	279539	19273.50	364838	25154.60
2150	148.23	69688	4804.80	88100	6074.20	281083	19379.90	366853	25293.60
2160	148.92	70071	4831.20	88585	6107.70	282630	19486.60	368873	25432.80
2170	149.61	70456	4857.70	89072	6141.20	284183	19593.70	370899	25572.50
2180	150.30	70842	4884.30	89560	6174.90	285739	19701.00	372930	25712.60
2190	150.99	71229	4911.00	90049	6208.60	287301	19808.70	374968	25853.10
2200	151.68	71618	4937.80	90540	6242.50	288867	19916.60	377012	25994.00
2210	152.37	72007	4964.70	91032	6276.40	290437	20024.90	379062	26135.40
2220	153.06	72398	4991.60	91526	6310.40	292013	20133.50	381118	26277.10
2230	153.75	72789	5018.60	92021	6344.60	293593	20242.50	383181	26419.30
2240	154.44	73182	5045.70	92518	6378.80	295178	20351.80	385249	26561.90
2250	155.13	73577	5072.90	93017	6413.20	296768	20461.40	387325	26705.10
2260	155.82	73972	5100.10	93517	6447.70	298364	20571.40	389407	26848.60
2270	156.51	74369	5127.50	94018	6482.30	299964	20681.70	391495	26992.60
2280	157.20	74767	5155.00	94521	6516.90	301569	20792.40	393590	27137.00
2290	157.88	75166	5182.50	95026	6551.80	303180	20903.50	395692	27282.00
2300	158.57	75567	5210.10	95533	6586.70	304796	21014.90	397801	27427.40
2310	159.26	75969	5237.80	96041	6621.70	306417	21126.70	399917	27573.30
2320	159.95	76372	5265.60	96551	6656.90	308044	21238.80	402040	27719.60
2330	160.64	76777	5293.50	97062	6692.10	309676	21351.40	404171	27866.60
2340	161.33	77183	5321.50	97576	6727.60	311314	21464.30	406308	28013.90
2350	162.02	77590	5349.60	98091	6763.10	312957	21577.60	408453	28161.80
2360	162.71	77999	5377.80	98608	6798.70	314606	21691.30	410606	28310.20
2370	163.40	78409	5406.10	99126	6834.40	316262	21805.40	412766	28459.20
2380	164.09	78821	5434.50	99647	6870.40	317923	21920.00	414934	28608.60
2390	164.78	79235	5463.00	100170	6906.40	319590	22034.90	417110	28758.70
2400	165.47	79649	5491.60	100694	6942.60	321263	22150.30	419293	28909.20
2410	166.16	80066	5520.30	101220	6978.80	322942	22266.00	421485	29060.30
2420	166.85	80484	5549.10	101749	7015.30	324628	22382.30	423685	29212.00
2430	167.54	80903	5578.00	102279	7051.80	326320	22498.90	425893	29364.20
2440	168.23	81324	5607.00	102811	7088.50	328018	22616.00	428110	29517.10
2450	168.92	81747	5636.20	103346	7125.40	329723	22733.50	430335	29670.50
2460	169.61	82171	5665.40	103882	7162.40	331435	22851.60	432569	29824.50
2470	170.30	82597	5694.80	104421	7199.50	333153	22970.00	434812	29979.20
2480	170.98	83025	5724.30	104962	7236.80	334878	23089.00	437064	30134.50
2490	171.67	83454	5753.90	105504	7274.20	336611	23208.50	439324	30290.30

Note:

- The minimum set pressure is 50 psig (3.45 barg). For set pressures 50 psig (3.45 barg) to 99 psig (6.83 barg) contact the factory.

Orifice Capacities

W = Slope x P for P ≤ 1580 psia

P = (1.03 x set pressure) + 14.7

W = Slope x P x $\left[\frac{0.1906 \times P - 1000}{0.2292 \times P - 1061} \right]$ For P > 1580 psia

Valve Capacity - Non-ASME Code Rated, for Saturated Steam. The saturated steam table for Non-ASME Section I is based at 3 percent overpressure or 2 psig (0.14 barg), whichever is greater, showing 100 percent actual capacity.

Slope		in.	mm	in.	mm	in.	mm	in.	mm
		29.90	759.5	37.80	960.1	120.60	3063.2	157.40	3998.0
Flow Area		in ²	cm ²	in ²	cm ²	in ²	cm ²	in ²	cm ²
		0.875	5.645	1.000	6.452	1.750	11.290	2.000	12.903
Designation		35X5		35X6		35X7		35X8	
Set Pressure ¹		Orifice Capacity							
psig	barg	lb/hr	kg/hr	lb/hr	kg/hr	lb/hr	kg/hr	lb/hr	kg/hr
2500	172.36	83886	5783.70	106050	7311.80	338350	23328.40	441594	30446.80
2510	173.05	—	—	—	—	340096	23448.70	443874	30604.00
2520	173.74	—	—	—	—	341850	23569.70	446163	30761.80
2530	174.43	—	—	—	—	343611	23691.10	448461	30920.20
2540	175.12	—	—	—	—	345380	23813.10	450769	31079.40
2550	175.81	—	—	—	—	347156	23935.50	453088	31239.30
2560	176.50	—	—	—	—	348940	24058.50	455416	31399.80
2570	177.19	—	—	—	—	350732	24182.10	457755	31561.00
2580	177.88	—	—	—	—	352532	24306.20	460104	31723.00
2590	178.57	—	—	—	—	354340	24430.80	462463	31885.70
2600	179.26	—	—	—	—	356156	24556.00	464834	32049.10
2610	179.95	—	—	—	—	357980	24681.80	467215	32213.30
2620	180.64	—	—	—	—	359813	24808.20	469607	32378.20
2630	181.33	—	—	—	—	361655	24935.20	472011	32544.00
2640	182.02	—	—	—	—	363506	25062.80	474426	32710.50
2650	182.71	—	—	—	—	365365	25191.00	476853	32877.80
2660	183.40	—	—	—	—	367234	25319.80	479292	33046.00
2670	184.09	—	—	—	—	369111	25449.30	481743	33215.00
2680	184.77	—	—	—	—	370999	25579.40	484206	33384.80
2690	185.46	—	—	—	—	372895	25710.20	486681	33555.40
2700	186.15	—	—	—	—	374802	25841.60	489169	33727.00
2710	186.84	—	—	—	—	376718	25973.70	491670	33899.40
2720	187.53	—	—	—	—	378644	26106.50	494184	34072.70
2730	188.22	—	—	—	—	380581	26240.10	496712	34247.00
2740	188.91	—	—	—	—	382528	26374.30	499253	34422.20
2750	189.60	—	—	—	—	384485	26509.30	501807	34598.30
2760	190.29	—	—	—	—	386453	26644.90	504376	34775.40
2770	190.98	—	—	—	—	388432	26781.40	506959	34953.50
2780	191.67	—	—	—	—	390423	26918.70	509557	35132.70
2790	192.36	—	—	—	—	392424	27056.60	512169	35312.80
2800	193.05	—	—	—	—	394438	27195.50	514797	35494.00
2810	193.74	—	—	—	—	396462	27335.00	517440	35676.20
2820	194.43	—	—	—	—	398499	27475.50	520098	35859.40
2830	195.12	—	—	—	—	400548	27616.80	522772	36043.80
2840	195.81	—	—	—	—	402610	27758.90	525463	36229.30
2850	196.50	—	—	—	—	404684	27901.90	528169	36415.90
2860	197.19	—	—	—	—	406771	28045.80	530893	36603.70
2870	197.87	—	—	—	—	408870	28190.50	533634	36792.70
2880	198.56	—	—	—	—	410984	28336.30	536392	36982.90
2890	199.25	—	—	—	—	413111	28482.90	539168	37174.30
2900	199.94	—	—	—	—	415251	28630.50	541962	37366.90
2910	200.63	—	—	—	—	417406	28779.10	544774	37560.80
2920	201.32	—	—	—	—	419575	28928.60	547605	37756.00
2930	202.01	—	—	—	—	421759	29079.20	550456	37952.60
2940	202.70	—	—	—	—	423958	29230.80	553325	38150.40
2950	203.39	—	—	—	—	426172	29383.50	556215	38349.60
2960	204.08	—	—	—	—	428402	29537.20	559125	38550.30
2970	204.77	—	—	—	—	430647	29692.00	562056	38752.30
2980	205.46	—	—	—	—	432909	29848.00	565007	38955.80
2990	206.15	—	—	—	—	435187	30005.00	567981	39160.90
3000	206.84	—	—	—	—	437482	30163.30	570976	39367.40
3010	207.53	—	—	—	—	439794	30322.70	573993	39575.40
3020	208.22	—	—	—	—	442124	30483.30	577034	39785.00
3030	208.91	—	—	—	—	444471	30645.10	580098	39996.30
3040	209.60	—	—	—	—	446837	30808.30	583185	40209.10
3050	210.29	—	—	—	—	449221	30972.60	586297	40423.70
3060	210.97	—	—	—	—	451625	31138.40	589434	40640.00
3070	211.66	—	—	—	—	454048	31305.50	592596	40858.00
3080	212.35	—	—	—	—	456490	31473.80	595784	41077.80
3090	213.04	—	—	—	—	458953	31643.60	598999	41299.50

Note:

- The minimum set pressure is 50 psig (3.45 barg). For set pressures 50 psig (3.45 barg) to 99 psig (6.83 barg) contact the factory.

Orifice Capacities

$$W = 1135.8 \times \frac{0.9}{51.45} \times \text{Slope} \times \sqrt{\frac{P}{V}}$$

$$P = (\text{Set} \times 1.03) + 14.7$$

$$\text{Slope} = 120.6$$

$$V = \text{Specific Volume}$$

For Non-Code applications multiply capacity by 1.1

Valve Capacity - Non-ASME Code Rated, for Saturated Steam. The saturated steam table for Non-ASME Section I is based at 3 percent overpressure or 2 psig (0.14 barg), whichever is greater, showing 100 percent actual capacity.

Temperature		°F	°C	°F	°C	°F	°C	°F	°C	°F	°C
		750	398.9	760	404.4	770	410.0	780	415.6	790	421.1
Set Pressure ¹		Orifice Capacity									
psig	barg	lb/hr	kg/hr	lb/hr	kg/hr	lb/hr	kg/hr	lb/hr	kg/hr	lb/hr	kg/hr
3100	213.73	377402	26020.90	369212	25456.20	361533	24926.80	354435	24437.40	347625	23967.80
3150	217.18	387217	26697.60	378376	26088.10	370115	25518.50	362499	24993.40	355215	24491.20
3200	220.63	397331	27395.00	387786	26736.90	379041	26133.90	370728	25560.70	363064	25032.30
3250	224.07	407758	28113.90	397613	27414.40	388038	26754.20	379264	26149.30	370928	25574.50
3300	227.52	418695	28868.00	407720	28111.30	397405	27400.10	387984	26750.50	379063	26135.40
3350	230.97	429996	29647.10	417935	28815.60	407004	28061.90	396732	27353.70	387346	26706.50
3400	234.42	441890	30467.20	428818	29565.90	416841	28740.10	405981	27991.40	395774	27287.60
3450	237.86	454438	31332.30	440244	30353.70	427302	29461.40	415262	28631.30	404348	27878.80
3500	241.31	467714	32247.70	452045	31167.40	438055	30202.80	425103	29309.80	413405	28503.20
3550	244.76	482066	33237.20	464714	32040.90	449109	30964.90	435174	30004.10	422281	29115.20
3600	248.21	497369	34292.30	478112	32964.60	460931	31780.00	445686	30728.90	431672	29762.70
3650	251.65	513744	35421.40	492323	33944.40	473375	32638.00	456679	31486.90	441435	30435.80
3700	255.10	531681	36658.10	507741	35007.50	486506	33543.40	467963	32264.90	451181	31107.80
3750	258.55	550703	37969.60	523585	36099.90	500116	34481.70	479543	33063.30	461317	31806.60
3800	262.00	571336	39392.20	540533	37268.40	514530	35475.50	491688	33900.60	471874	32534.50
3850	265.44	593842	40943.90	559114	38549.50	529842	36531.30	504453	34780.80	482641	33276.90
3900	268.89	616007	42472.10	577109	39790.20	544757	37559.60	517300	35666.50	493615	34033.50
3950	272.34	637963	43985.90	595083	41029.50	559830	38598.90	529863	36532.70	504518	34785.20
4000	275.79	662414	45671.80	614332	42356.60	575399	39672.30	543376	37464.40	515877	35568.40
4050	279.23	688513	47471.20	635028	43783.60	592340	40840.40	557245	38420.60	527729	36385.60
4100	282.68	709738	48934.70	652189	44966.80	607155	41861.80	569942	39296.10	539149	37173.00
4150	286.13	728510	50228.90	668527	46093.30	620789	42801.80	582406	40155.40	550025	37922.80
4200	289.57	749195	51655.10	685722	47278.80	636057	43854.50	595400	41051.30	562015	38749.50
4250	293.02	771195	53172.00	703864	48529.70	651560	44923.40	608966	41986.70	574138	39585.40
4300	296.47	786919	54256.10	717920	49498.80	664953	45846.80	621737	42867.20	586377	40429.20
4350	299.92	802248	55313.00	732501	50504.10	678265	46764.70	634529	43749.20	598292	41250.70
4400	303.36	817083	56335.80	746847	51493.20	692080	47717.20	647827	44666.00	611105	42134.20
4450	306.81	833505	57468.10	762557	52576.40	706435	48706.90	661670	45620.50	624001	43023.30
4500	310.26	844857	58250.80	774531	53402.00	719273	49592.10	673799	46456.80	636467	43882.80

Note:

1. The minimum set pressure is 50 psig (3.45 barg). For set pressures 50 psig (3.45 barg) to 99 psig (6.83 barg) contact the factory.

Orifice Capacities

$$W = 1135.8 \times \frac{0.9}{51.45} \times \text{Slope} \times \sqrt{\frac{P}{V}}$$

$$P = (\text{Set} \times 1.03) + 14.7$$

$$\text{Slope} = 120.6$$

$$V = \text{Specific Volume}$$

For Non-Code applications multiply capacity by 1.1

Valve Capacity - Non-ASME Code Rated, for Saturated Steam. The saturated steam table for Non-ASME Section I is based at 3 percent overpressure or 2 psig (0.14 barg), whichever is greater, showing 100 percent actual capacity.

Temperature		°F	°C	°F	°C	°F	°C	°F	°C	°F	°C
		800	426.7	810	432.2	820	437.8	830	443.3	840	448.9
Set Pressure ¹		Orifice Capacity									
psig	barg	lb/hr	kg/hr	lb/hr	kg/hr	lb/hr	kg/hr	lb/hr	kg/hr	lb/hr	kg/hr
3100	213.73	341193	23524.40	336648	23211.00	332281	22909.90	327983	22613.60	323940	22334.80
3150	217.18	348353	24018.00	343595	23690.00	339027	23375.00	334537	23065.50	330316	22774.40
3200	220.63	355739	24527.30	350753	24183.50	345863	23846.40	341276	23530.10	336767	23219.20
3250	224.07	363242	25044.60	357900	24676.30	352900	24331.50	347996	23993.40	343395	23676.20
3300	227.52	370861	25569.90	365265	25184.10	360034	24823.40	354907	24469.90	350102	24138.60
3350	230.97	378459	26093.80	372604	25690.10	367136	25313.10	361783	24944.00	356772	24598.50
3400	234.42	386300	26634.40	380168	26211.60	374319	25808.30	368856	25431.70	363507	25062.90
3450	237.86	394251	27182.60	387831	26740.00	381714	26318.20	375878	25915.80	370302	25531.40
3500	241.31	402466	27749.00	395737	27285.10	389193	26833.90	383099	26413.70	377153	26003.70
3550	244.76	410470	28300.90	403281	27805.20	396605	27344.90	390109	26897.00	384056	26479.70
3600	248.21	418901	28882.20	411371	28363.00	404233	27870.80	397601	27413.60	391144	26968.40
3650	251.65	427622	29483.40	419726	28939.00	412253	28423.80	405011	27924.50	398285	27460.70
3700	255.10	436274	30080.00	428008	29510.10	420027	28959.80	412636	28450.20	405470	27956.10
3750	258.55	445023	30683.20	436187	30074.00	428033	29511.80	420153	28968.50	412851	28465.00
3800	262.00	454069	31306.90	444814	30668.80	436102	30068.10	427883	29501.40	420112	28965.70
3850	265.44	463434	31952.60	453730	31283.50	444611	30654.80	435839	30050.00	427738	29491.40
3900	268.89	472912	32606.10	462527	31890.10	452998	31233.10	443845	30602.00	435404	30020.00
3950	272.34	482494	33266.70	471614	32516.60	461438	31815.00	451893	31156.90	442917	30538.00
4000	275.79	492170	33933.90	480776	33148.30	470139	32414.90	459973	31714.00	450631	31069.90
4050	279.23	502456	34643.10	490249	33801.40	479119	33034.00	468500	32301.90	458758	31630.20
4100	282.68	512585	35341.40	499795	34459.60	487917	33640.60	477070	32892.80	466708	32178.30
4150	286.13	522796	36045.50	509403	35122.00	496989	34266.10	485209	33453.90	474445	32711.80
4200	289.57	533682	36796.00	519338	35807.00	506353	34911.80	494053	34063.70	482833	33290.10
4250	293.02	544676	37554.00	529624	36516.20	515755	35560.00	503173	34692.50	491235	33869.40
4300	296.47	556098	38341.60	540285	37251.30	525748	36249.00	512062	35305.40	499635	34448.60
4350	299.92	567629	39136.60	550701	37969.40	535203	36900.90	521218	35936.70	508020	35026.70
4400	303.36	579994	39989.10	562166	38759.90	545575	37616.00	530658	36587.50	516636	35620.70
4450	306.81	592504	40851.70	573380	39533.10	555996	38334.50	540401	37259.30	525773	36250.70
4500	310.26	604724	41694.20	584646	40309.90	566444	39054.90	549532	37888.80	534334	36841.00

Note:

1. The minimum set pressure is 50 psig (3.45 barg). For set pressures 50 psig (3.45 barg) to 99 psig (6.83 barg) contact the factory.

Orifice Capacities

$$W = 1135.8 \times \frac{0.9}{51.45} \times \text{Slope} \times \sqrt{\frac{P}{V}}$$

$$P = (\text{Set} \times 1.03) + 14.7$$

$$\text{Slope} = 120.6$$

$$V = \text{Specific Volume}$$

For Non-Code applications multiply capacity by 1.1

Valve Capacity, ASME B&PV Code Section I, for Supercritical Steam. Applies to Valve 3547											
Temperature		°F	°C	°F	°C	°F	°C	°F	°C	°F	°C
		850	454.4	860	460.0	870	465.6	880	471.1	890	476.7
Set Pressure ¹		Orifice Capacity									
psig	barg	lb/hr	kg/hr	lb/hr	kg/hr	lb/hr	kg/hr	lb/hr	kg/hr	lb/hr	kg/hr
3100	213.73	320043	22066.10	316800	21842.50	313737	21631.40	310680	21420.60	307790	21221.30
3150	217.18	326251	22494.20	322961	22267.30	319682	22041.20	316585	21827.70	313493	21614.50
3200	220.63	332528	22926.90	329100	22690.60	325776	22461.40	322462	22232.90	319333	22017.20
3250	224.07	338871	23364.30	335300	23118.10	331839	22879.40	328391	22641.70	325138	22417.40
3300	227.52	345382	23813.20	341660	23556.60	338055	23308.00	334466	23060.60	331082	22827.20
3350	230.97	351854	24259.40	347978	23992.20	344227	23733.60	340496	23476.30	336979	23233.80
3400	234.42	358383	24709.60	354349	24431.50	350448	24162.50	346569	23895.00	342917	23643.20
3450	237.86	364966	25163.50	360768	24874.00	356712	24594.40	352790	24324.00	348994	24062.20
3500	241.31	371599	25620.80	367233	25319.80	363017	25029.10	358943	24748.20	355003	24476.50
3550	244.76	378148	26072.30	373613	25759.70	369237	25457.90	365127	25174.60	361040	24892.80
3600	248.21	384993	26544.30	380275	26219.00	375727	25905.40	371338	25602.80	367099	25310.50
3650	251.65	391882	27019.30	386976	26681.00	382251	26355.20	377818	26049.60	373416	25746.10
3700	255.10	398809	27496.90	393710	27145.30	388802	26806.90	384203	26489.80	379638	26175.10
3750	258.55	405767	27976.60	400471	27611.50	395376	27260.20	390605	26931.20	385873	26605.00
3800	262.00	412750	28458.10	407250	28078.80	401965	27714.50	397019	27373.40	392117	27035.50
3850	265.44	420072	28962.90	414352	28568.50	408860	28189.90	403724	27835.70	398639	27485.10
3900	268.89	427259	29458.40	421320	29048.90	415622	28656.10	410298	28289.00	405030	27925.80
3950	272.34	434456	29954.60	428293	29529.70	422385	29122.40	416870	28742.10	411417	28366.20
4000	275.79	441836	30463.50	435438	30022.30	429309	29599.80	423593	29205.70	417944	28816.20
4050	279.23	449410	30985.70	442763	30527.40	436402	30088.80	430473	29680.00	424621	29276.50
4100	282.68	456992	31508.40	450091	31032.60	443493	30577.70	437177	30142.20	431123	29724.80
4150	286.13	464367	32016.90	457216	31523.90	450386	31053.00	444031	30614.80	437767	30182.90
4200	289.57	472134	32552.40	464711	32040.60	457628	31552.30	451043	31098.30	444558	30651.10
4250	293.02	480108	33102.20	472398	32570.60	465048	32063.90	458031	31580.10	451323	31117.60
4300	296.47	488072	33651.30	480070	33099.60	472450	32574.20	464984	32059.50	458049	31581.30
4350	299.92	495777	34182.60	487490	33611.20	479606	33067.60	472092	32549.50	464920	32055.10
4400	303.36	503916	34743.70	495317	34150.90	487145	33587.40	479364	33050.90	471944	32539.30
4450	306.81	512273	35319.90	503346	34704.40	494870	34120.00	486590	33549.10	478920	33020.30
4500	310.26	520332	35875.60	511085	35238.00	502315	34633.30	493755	34043.20	485834	33497.00

Note:

1. The minimum set pressure is 50 psig (3.45 barg). For set pressures 50 psig (3.45 barg) to 99 psig (6.83 barg) contact the factory.

Orifice Capacities

$$W = 1135.8 \times \frac{0.9}{51.45} \times \text{Slope} \times \sqrt{\frac{P}{V}}$$

$$P = (\text{Set} \times 1.03) + 14.7$$

$$\text{Slope} = 120.6$$

$$V = \text{Specific Volume}$$

For Non-Code applications multiply capacity by 1.1

Valve Capacity, ASME B&PV Code Section I, for Supercritical Steam. Applies to Valve 3547											
Temperature		°F	°C	°F	°C	°F	°C	°F	°C	°F	°C
		900	482.2	910	487.8	920	493.3	930	498.9	940	504.4
Set Pressure ¹		Orifice Capacity									
psig	barg	lb/hr	kg/hr	lb/hr	kg/hr	lb/hr	kg/hr	lb/hr	kg/hr	lb/hr	kg/hr
3100	213.73	304902	21022.20	302469	20854.50	300093	20690.60	297844	20535.60	295575	20379.10
3150	217.18	310571	21413.10	308589	21276.40	306645	21142.40	304661	21005.60	302789	20876.50
3200	220.63	316293	21807.60	314559	21688.00	312854	21570.50	311097	21449.30	309447	21335.60
3250	224.07	321980	22199.70	319670	22040.40	317327	21878.90	315116	21726.40	312871	21571.60
3300	227.52	327798	22600.80	324960	22405.20	322194	22214.40	319498	22028.60	316869	21847.30
3350	230.97	333570	22998.80	330624	22795.70	327755	22597.90	325046	22411.10	322319	22223.10
3400	234.42	339377	23399.20	336322	23188.50	333439	22989.80	330539	22789.80	327801	22601.00
3450	237.86	345318	23808.80	342146	23590.10	339156	23383.90	336149	23176.60	333312	22981.00
3500	241.31	351190	24213.60	348004	23994.00	344804	23773.30	341786	23565.30	338753	23356.10
3550	244.76	357087	24620.20	353785	24392.60	350471	24164.10	347347	23948.70	344209	23732.30
3600	248.21	363003	25028.10	359583	24792.30	356258	24563.10	353023	24340.00	349875	24123.00
3650	251.65	369165	25453.00	365618	25208.40	362171	24970.80	358820	24739.70	355560	24514.90
3700	255.10	375232	25871.30	371558	25618.00	367990	25372.00	364634	25140.60	361260	24907.90
3750	258.55	381310	26290.30	377507	26028.10	373816	25773.70	370345	25534.30	366858	25293.90
3800	262.00	387393	26709.80	383458	26438.40	379763	26183.70	376054	25928.00	372567	25687.50
3850	265.44	393740	27147.40	389664	26866.30	385838	26602.50	382000	26337.90	378392	26089.20
3900	268.89	399960	27576.20	395743	27285.50	391787	27012.70	387821	26739.30	384095	26482.40
3950	272.34	406172	28004.50	401951	27713.50	397725	27422.10	393759	27148.70	389784	26874.60
4000	275.79	412516	28441.90	408151	28141.00	403783	27839.80	399686	27557.30	395581	27274.30
4050	279.23	419001	28889.10	414484	28577.60	410110	28276.00	405733	27974.30	401627	27691.20
4100	282.68	425315	29324.40	420649	29002.70	416134	28691.40	411761	28389.90	407523	28097.70
4150	286.13	431761	29768.80	426940	29436.40	422277	29114.90	417616	28793.60	413249	28492.50
4200	289.57	438345	30222.80	433362	29879.20	428545	29547.10	423732	29215.20	419226	28904.60
4250	293.02	444900	30674.70	439753	30319.90	434780	29977.00	429972	29645.50	425320	29324.70
4300	296.47	451416	31124.00	446102	30757.60	440973	30404.00	436179	30073.40	431380	29742.60
4350	299.92	458066	31582.50	452580	31204.20	447287	30839.30	442175	30486.80	437234	30146.20
4400	303.36	464859	32050.80	459192	31660.10	453727	31283.30	448453	30919.70	443359	30568.50
4450	306.81	471601	32515.70	465752	32112.40	460116	31723.80	454857	31361.20	449602	30998.90
4500	310.26	478281	32976.30	472250	32560.40	466441	32159.90	461024	31786.40	455615	31413.50

Note:

1. The minimum set pressure is 50 psig (3.45 barg). For set pressures 50 psig (3.45 barg) to 99 psig (6.83 barg) contact the factory.

Orifice Capacities

$$W = 1135.8 \times \frac{0.9}{51.45} \times \text{Slope} \times \sqrt{\frac{P}{V}}$$

$$P = (\text{Set} \times 1.03) + 14.7$$

$$\text{Slope} = 120.6$$

$$V = \text{Specific Volume}$$

For Non-Code applications multiply capacity by 1.1

Valve Capacity, ASME B&PV Code Section I, for Supercritical Steam. Applies to Valve 3547											
Temperature		°F	°C	°F	°C	°F	°C	°F	°C	°F	°C
		950	510.0	960	515.6	970	521.1	980	526.7	990	532.2
Set Pressure ¹		Orifice Capacity									
psig	barg	lb/hr	kg/hr	lb/hr	kg/hr	lb/hr	kg/hr	lb/hr	kg/hr	lb/hr	kg/hr
3100	213.73	293357	20226.20	291255	20081.30	289197	19939.40	287183	19800.50	285210	19664.50
3150	217.18	300952	20749.90	298292	20566.50	295702	20387.90	293112	20209.30	290653	20039.80
3200	220.63	307823	21223.60	304724	21009.90	301718	20802.70	298869	20606.20	296030	20410.50
3250	224.07	310750	21425.40	308141	21245.50	305596	21070.10	303113	20898.90	300690	20731.80
3300	227.52	314303	21670.40	312031	21513.70	309807	21360.40	307556	21205.20	305426	21058.30
3350	230.97	319659	22039.70	317305	21877.40	315002	21718.60	312748	21563.20	310542	21411.10
3400	234.42	325045	22411.00	322606	22242.80	320303	22084.10	317969	21923.10	315763	21771.00
3450	237.86	330457	22784.20	328018	22616.00	325632	22451.50	323215	22284.80	320932	22127.40
3500	241.31	335891	23158.80	333366	22984.70	330898	22814.60	328484	22648.10	326122	22485.30
3550	244.76	341249	23528.20	338639	23348.30	336089	23172.50	333684	23006.70	331243	22838.30
3600	248.21	346810	23911.70	344110	23725.50	341471	23543.50	338893	23365.80	336372	23192.00
3650	251.65	352388	24296.20	349594	24103.60	346866	23915.50	344295	23738.30	341688	23558.50
3700	255.10	357978	24681.70	355089	24482.50	352270	24288.10	349613	24104.90	346921	23919.30
3750	258.55	363467	25060.10	360485	24854.50	357677	24660.90	354833	24464.80	352154	24280.10
3800	262.00	369063	25445.90	366091	25241.00	363083	25033.60	360252	24838.40	357384	24640.70
3850	265.44	374770	25839.40	371699	25627.70	368701	25421.00	365669	25211.90	362814	25015.10
3900	268.89	380356	26224.60	377187	26006.10	374096	25793.00	371079	25584.90	368134	25381.90
3950	272.34	386049	26617.10	382778	26391.60	379588	26171.60	376477	25957.10	373442	25747.90
4000	275.79	391727	27008.60	388352	26775.90	385064	26549.20	381975	26336.20	378844	26120.30
4050	279.23	397644	27416.50	394159	27176.30	390763	26942.10	387575	26722.30	384346	26499.70
4100	282.68	403414	27814.40	399820	27566.60	396320	27325.30	393035	27098.80	389709	26869.40
4150	286.13	409016	28200.60	405316	27945.50	401846	27706.30	398335	27464.20	395040	27237.00
4200	289.57	414860	28603.50	411185	28350.20	407470	28094.00	403986	27853.80	400461	27610.80
4250	293.02	420816	29014.20	417026	28752.90	413197	28488.90	409607	28241.40	405977	27991.10
4300	296.47	426736	29422.40	422831	29153.10	418887	28881.20	415191	28626.40	411455	28368.80
4350	299.92	432455	29816.70	428438	29539.70	424531	29270.30	420584	28998.20	416886	28743.20
4400	303.36	438434	30228.90	434297	29943.70	430274	29666.30	426361	29396.50	422553	29134.00
4450	306.81	444526	30648.90	440262	30354.90	436119	30069.30	432091	29791.60	428173	29521.40
4500	310.26	450392	31053.40	446008	30751.10	441749	30457.50	437767	30182.90	433738	29905.10

Note:

1. The minimum set pressure is 50 psig (3.45 barg). For set pressures 50 psig (3.45 barg) to 99 psig (6.83 barg) contact the factory.

Orifice Capacities

$$W = 1135.8 \times \frac{0.9}{51.45} \times \text{Slope} \times \sqrt{\frac{P}{V}}$$

$$P = (\text{Set} \times 1.03) + 14.7$$

$$\text{Slope} = 120.6$$

$$V = \text{Specific Volume}$$

For Non-Code applications multiply capacity by 1.1

Valve Capacity, ASME B&PV Code Section I, for Supercritical Steam. Applies to Valve 3547											
Temperature		°F	°C	°F	°C	°F	°C	°F	°C	°F	°C
		1000	537.8	1010	543.3	1020	548.9	1030	554.4	1040	560.0
Set Pressure ¹		Orifice Capacity									
psig	barg	lb/hr	kg/hr	lb/hr	kg/hr	lb/hr	kg/hr	lb/hr	kg/hr	lb/hr	kg/hr
3100	213.73	283277	19531.20	281565	19413.20	279883	19297.20	278231	19183.30	276608	19071.40
3150	217.18	288256	19874.50	286480	19752.00	284737	19631.90	283025	19513.80	281344	19397.90
3200	220.63	293272	20220.30	290782	20048.70	288292	19877.00	285927	19713.90	283558	19550.60
3250	224.07	298324	20568.70	292321	20154.80	286666	19764.90	281385	19400.80	276331	19052.30
3300	227.52	303340	20914.50	295600	20380.90	288363	19881.90	281689	19421.70	275406	18988.50
3350	230.97	308382	21262.10	303912	20953.90	299698	20663.40	295589	20380.10	291708	20112.50
3400	234.42	313526	21616.80	311486	21476.20	309484	21338.10	307593	21207.70	305666	21074.90
3450	237.86	318697	21973.30	316585	21827.70	314515	21685.00	312559	21550.10	310566	21412.70
3500	241.31	323810	22325.90	321627	22175.40	319566	22033.20	317467	21888.50	315484	21751.80
3550	244.76	328855	22673.70	326683	22523.90	324473	22371.60	322386	22227.70	320261	22081.20
3600	248.21	333906	23022.00	331664	22867.40	329467	22715.90	327313	22567.40	325201	22421.80
3650	251.65	339139	23382.80	336823	23223.10	334554	23066.60	332415	22919.20	330233	22768.70
3700	255.10	344290	23737.90	341899	23573.10	339647	23417.80	337352	23259.60	335188	23110.30
3750	258.55	349440	24093.00	347068	23929.40	344652	23762.90	342376	23605.90	340056	23446.00
3800	262.00	354683	24454.50	352236	24285.80	349839	24120.50	347397	23952.10	345097	23793.50
3850	265.44	360025	24822.80	357499	24648.60	355026	24478.10	352507	24304.50	350135	24140.90
3900	268.89	365259	25183.70	362655	25004.10	360107	24828.50	357611	24656.40	355167	24487.90
3950	272.34	370478	25543.50	367796	25358.60	365172	25177.70	362704	25007.50	360187	24834.00
4000	275.79	375789	25909.70	373026	25719.20	370429	25540.10	367781	25357.60	365292	25185.90
4050	279.23	381196	26282.50	378460	26093.80	375672	25901.60	373053	25721.00	370381	25536.80
4100	282.68	386466	26645.80	383650	26451.70	380781	26253.90	378087	26068.10	375340	25878.70
4150	286.13	391703	27006.90	388807	26807.20	385974	26611.90	383202	26420.80	380489	26233.70
4200	289.57	397153	27382.70	394170	27177.00	391254	26976.00	388402	26779.30	385611	26586.90
4250	293.02	402571	27756.20	399502	27544.60	396502	27337.80	393689	27143.80	390817	26945.80
4300	296.47	407951	28127.20	404794	27909.50	401710	27696.90	398820	27497.60	395869	27294.20
4350	299.92	413284	28494.90	410040	28271.20	407003	28061.80	403903	27848.10	400999	27647.90
4400	303.36	418845	28878.30	415507	28648.10	412383	28432.80	409196	28213.00	406211	28007.20
4450	306.81	424359	29258.50	421069	29031.60	417716	28800.50	414576	28584.00	411375	28363.30
4500	310.26	429818	29634.90	426438	29401.80	422994	29164.40	419771	28942.10	416485	28715.60

Note:

1. The minimum set pressure is 50 psig (3.45 barg). For set pressures 50 psig (3.45 barg) to 99 psig (6.83 barg) contact the factory.

Orifice Capacities

$$W = 1135.8 \times \frac{0.9}{51.45} \times \text{Slope} \times \sqrt{\frac{P}{V}}$$

$$P = (\text{Set} \times 1.03) + 14.7$$

$$\text{Slope} = 120.6$$

$$V = \text{Specific Volume}$$

For Non-Code applications multiply capacity by 1.1

Valve Capacity, ASME B&PV Code Section I, for Supercritical Steam. Applies to Valve 3547														
Temperature			°F	°C	°F	°C	°F	°C	°F	°C	°F	°C	°F	°C
			1050	565.6	1060	571.1	1070	576.7	1080	582.2	1090	587.8	1100	593.3
Set Pressure ¹		Valve Capacity												
psig	barg	lb/hr	kg/hr	lb/hr	kg/hr	lb/hr	kg/hr	lb/hr	kg/hr	lb/hr	kg/hr	lb/hr	kg/hr	
3100	213.73	275013	18961.40	273501	18857.20	272014	18754.70	270604	18657.40	269163	18558.10	267745	18460.30	
3150	217.18	279693	19284.10	278185	19180.10	276645	19074.00	275185	18973.30	273694	18870.50	272281	18773.10	
3200	220.63	281306	19395.30	280432	19335.10	279509	19271.40	278651	19212.30	277745	19149.80	276903	19091.70	
3250	224.07	271540	18722.00	273426	18852.00	275406	18988.50	277375	19124.30	279443	19266.90	281501	19408.80	
3300	227.52	269574	18586.40	272676	18800.30	275833	19018.00	279158	19247.20	282549	19481.00	286126	19727.60	
3350	230.97	287915	19851.00	288457	19888.40	289062	19930.10	289610	19967.90	290222	20010.10	290777	20048.30	
3400	234.42	303774	20944.40	302053	20825.80	300361	20709.10	298632	20589.90	296996	20477.10	295388	20366.20	
3450	237.86	308610	21277.90	306833	21155.30	305085	21034.80	303367	20916.40	301678	20799.90	300016	20685.30	
3500	241.31	313464	21612.50	311627	21485.90	309823	21361.50	308120	21244.10	306375	21123.80	304660	21005.50	
3550	244.76	318254	21942.80	316360	21812.20	314572	21688.90	312742	21562.80	311015	21443.70	309246	21321.70	
3600	248.21	323129	22278.90	321252	22149.50	319330	22017.00	317517	21892.00	315662	21764.10	313910	21643.30	
3650	251.65	328093	22621.20	326154	22487.50	324250	22356.20	322301	22221.80	320463	22095.10	318656	21970.50	
3700	255.10	332981	22958.20	330982	22820.40	329019	22685.00	327170	22557.50	325273	22426.70	323409	22298.20	
3750	258.55	337869	23295.20	335809	23153.20	333786	23013.70	331881	22882.30	329928	22747.70	328009	22615.40	
3800	262.00	342841	23638.00	340717	23491.60	338719	23353.80	336670	23212.50	334741	23079.50	332763	22943.20	
3850	265.44	347811	23980.70	345712	23836.00	343563	23687.80	341540	23548.30	339467	23405.40	337515	23270.80	
3900	268.89	352772	24322.70	350611	24173.70	348489	24027.40	346315	23877.50	344270	23736.50	342261	23598.00	
3950	272.34	357721	24663.90	355496	24510.50	353312	24360.00	351076	24205.80	348973	24060.80	346906	23918.30	
4000	275.79	362752	25010.80	360462	24852.90	358214	24697.90	356008	24545.80	353842	24396.50	351715	24249.80	
4050	279.23	367870	25363.70	365511	25201.00	363197	25041.50	360926	24884.90	358697	24731.20	356509	24580.40	
4100	282.68	372759	25700.80	370335	25533.60	368060	25376.80	365725	25215.80	363534	25064.70	361284	24909.60	
4150	286.13	377833	26050.60	375339	25878.70	372999	25717.30	370599	25551.90	368346	25396.50	366034	25237.10	
4200	289.57	382879	26398.50	380425	26229.30	377910	26055.90	375550	25893.20	373130	25726.40	370858	25569.70	
4250	293.02	388007	26752.10	385484	26578.10	383009	26407.50	380473	26232.60	378093	26068.50	375757	25907.50	
4300	296.47	392983	27095.20	390392	26916.50	387852	26741.40	385360	26569.60	382916	26401.10	380518	26235.70	
4350	299.92	398034	27443.40	395373	27260.00	392765	27080.10	390208	26903.80	387700	26730.90	385240	26561.30	
4400	303.36	403164	27797.10	400431	27608.70	397752	27424.00	395245	27251.10	392668	27073.50	390142	26899.30	
4450	306.81	408376	28156.50	405567	27962.80	402816	27773.10	400241	27595.60	397596	27413.20	395003	27234.40	
4500	310.26	413407	28503.40	410526	28304.70	407832	28119.00	405065	27928.20	402476	27749.70	399816	27566.30	

Note:

1. The minimum set pressure is 50 psig (3.45 barg). For set pressures 50 psig (3.45 barg) to 99 psig (6.83 barg) contact the factory.

Orifice Capacities

$$W = 1135.8 \times \frac{0.9}{51.45} \times \text{Slope} \times \sqrt{\frac{P}{V}}$$

$$P = (\text{Set} \times 1.03) + 14.7$$

$$\text{Slope} = 120.6$$

$$V = \text{Specific Volume}$$

For Non-Code applications multiply capacity by 1.1

Valve Capacity, ASME B&PV Code Section I, for Supercritical Steam. Applies to Valve 3547											
Temperature		°F	°C	°F	°C	°F	°C	°F	°C	°F	°C
		1110	598.9	1120	604.4	1130	610.0	1140	615.6	1150	621.1
Set Pressure ¹		Valve Capacity									
psig	barg	lb/hr	kg/hr	lb/hr	kg/hr	lb/hr	kg/hr	lb/hr	kg/hr	lb/hr	kg/hr
3100	213.73	266452	18371.20	265177	18283.30	263920	18196.60	262681	18111.20	261411	18023.60
3150	217.18	270942	18680.70	269623	18589.80	268375	18503.80	267093	18415.40	265829	18328.20
3200	220.63	275517	18996.20	274206	18905.80	272861	18813.10	271587	18725.20	270279	18635.00
3250	224.07	280124	19313.80	278711	19216.40	277375	19124.30	276058	19033.50	274706	18940.30
3300	227.52	284702	19629.50	283300	19532.80	281918	19437.50	280556	19343.60	279158	19247.20
3350	230.97	289305	19946.80	287855	19846.90	286427	19748.40	285020	19651.40	283634	19555.80
3400	234.42	293868	20261.40	292433	20162.50	290958	20060.80	289565	19964.80	288132	19866.00
3450	237.86	298512	20581.60	296966	20475.00	295506	20374.40	294006	20270.90	292590	20173.30
3500	241.31	303107	20898.40	301578	20793.00	300006	20684.60	298523	20582.40	297062	20481.70
3550	244.76	307645	21211.30	306069	21102.70	304516	20995.60	302987	20890.20	301481	20786.30
3600	248.21	312259	21529.40	310704	21422.20	309102	21311.80	307525	21203.10	305972	21096.00
3650	251.65	316952	21853.00	315348	21742.40	313697	21628.60	312141	21521.30	310540	21410.90
3700	255.10	321728	22182.30	319999	22063.10	318370	21950.80	316766	21840.20	315115	21726.40
3750	258.55	326278	22496.00	324575	22378.60	322899	22263.10	321248	22149.20	319549	22032.10
3800	262.00	330981	22820.30	329226	22699.30	327500	22580.30	325800	22463.10	324127	22347.70
3850	265.44	335679	23144.20	333955	23025.30	332176	22902.70	330426	22782.00	328703	22663.20
3900	268.89	340371	23467.70	338596	23345.30	336767	23219.20	335047	23100.60	333274	22978.40
3950	272.34	345051	23790.40	343140	23658.60	341344	23534.80	339577	23413.00	337754	23287.30
4000	275.79	349806	24118.20	347928	23988.70	345993	23855.30	344175	23730.00	342386	23606.60
4050	279.23	354546	24445.00	352615	24311.90	350715	24180.90	348845	24052.00	347005	23925.10
4100	282.68	359266	24770.50	357281	24633.60	355329	24499.00	353408	24366.60	351519	24236.30
4150	286.13	363961	25094.20	362019	24960.30	360013	24822.00	358039	24685.90	356098	24552.00
4200	289.57	368727	25422.80	366732	25285.20	364671	25143.10	362741	25010.10	360746	24872.50
4250	293.02	373670	25763.60	371516	25615.10	369500	25476.10	367417	25332.50	365465	25197.90
4300	296.47	378377	26088.10	376167	25935.80	374098	25793.10	372063	25652.80	369961	25507.90
4350	299.92	383043	26409.80	380884	26261.00	378761	26114.60	376673	25970.60	374517	25822.00
4400	303.36	387887	26743.80	385670	26591.00	383491	26440.70	381349	26293.00	379242	26147.80
4450	306.81	392689	27074.90	390415	26918.10	388291	26771.70	386092	26620.10	383930	26471.00
4500	310.26	397444	27402.70	395228	27250.00	392936	27091.90	390682	26936.50	388468	26783.90

Note:

1. The minimum set pressure is 50 psig (3.45 barg). For set pressures 50 psig (3.45 barg) to 99 psig (6.83 barg) contact the factory.

Orifice Capacities

Reduced Bore Selection and Capacity Factor

Reduced Bore Selection							
Inlet Size		Valve Types	Bore Size		Orifice Area		Relative to Full Bore (percent)
in.	mm		in.	mm	in ²	cm ²	
1.50	38.1	3515 and 3525	.88 ¹	22.2 ¹	0.601	3.880	100
			.84	21.4	0.559	3.610	93
			.81	20.7	0.518	3.340	86.2
			.78	19.8	0.479	3.090	79.7
			.75	19.1	0.442	2.850	73.5
			.72	18.3	0.406	2.620	67.6
			.69	17.5	0.371	2.390	61.7
			.66	16.7	0.338	2.180	56.2
			.63	15.9	0.307	1.980	51.1
			.59	15.1	0.277	1.790	46.1
2.00	50.8	3516 and 3526	1.00 ¹	25.4 ¹	0.785	5.060	100
			.97	24.6	0.737	4.750	93.9
			.94	23.8	0.690	4.450	87.9
			.91	23.0	0.645	4.160	82.2
			.88	22.2	0.601	3.880	76.6
			.84	21.4	0.559	3.610	71.2
			.81	20.7	0.518	3.340	66
			.78	19.8	0.479	3.090	61
			.75	19.1	0.442	2.850	56.3
			.72	18.2	0.404	2.610	51.5
2.50	63.5	3517, 3527, 3537 and 3547	1.75 ¹	44.5 ¹	2.405	15.520	100
			1.72	43.7	2.320	14.970	96.5
			1.69	42.9	2.237	14.430	93
			1.66	42.1	2.154	13.900	89.6
			1.63	41.3	2.074	13.380	86.2
			1.59	40.5	1.995	12.870	83
			1.56	39.7	1.917	12.370	79.7
			1.53	38.9	1.842	11.880	76.6
			1.50	38.1	1.767	11.400	73.5
			1.47	37.3	1.694	10.930	70.4
			1.44	36.5	1.623	10.470	67.5
			1.41	35.7	1.553	10.020	64.6
			1.38	34.9	1.485	9.580	61.7
			1.34	34.1	1.418	9.150	59
			1.31	33.4	1.353	8.730	56.3
			1.28	32.5	1.289	8.320	53.6
			1.19	30.2	1.108	7.150	46.1
			1.16	29.4	1.050	6.770	43.7
1.13	28.6	.994	6.410	41.3			
1.09	27.8	.940	6.060	39.1			
1.06	27.0	.887	5.720	36.9			
1.03	26.2	.835	5.390	34.7			
1.00	25.4	.785	5.060	32.6			

Note:

1. Full Bore comparison for this bore size

Orifice Capacities

Reaction Forces

When the Consolidated 3500 EBV is closed, an upward force is exerted in the valve neck (FP) by valve internal pressure. Valve necks are designed to resist the force and circumferential stresses caused by valve internal pressure.

When the valve opens, the force remains constant until some overpressure occurs. The force resulting from set pressure plus overpressure (F_{SP}) must be balanced by resisting forces in the valve neck.

Once flow has been established, the steam escapes upward through the discharge connection, resulting in force (F_R) acting downward at the center line of the discharge pipe.

Force F_R is represented by the equation:

$$F = MV + PA$$

A = Area of outlet, sq. in.

$$M = \frac{W}{g} = \frac{\text{lb/sec}}{\text{ft/sec}^2} = \frac{\text{lb} \cdot \text{sec}}{\text{ft}}$$

P = Static pressure, lb/sq. in.

V = Velocity, ft/sec

In addition to actual valve capacities, reaction forces for valves are based on pressure, temperature and valve configuration. Forces for a particular valve type apply regardless of the inlet connection used (for instance, flange, screwed, or welded).

For valve installations that vent to a closed system or solidly piped discharge lines, changes that occur in reaction forces and the effects on nozzles, headers, and discharge lines should be considered.

Force values indicated apply only when valves have been installed in accordance with ASME Code or BHGE recommendations.

Typical Vertical Discharge Consolidated EBV



Orifice Capacities

Reaction Forces - Steam

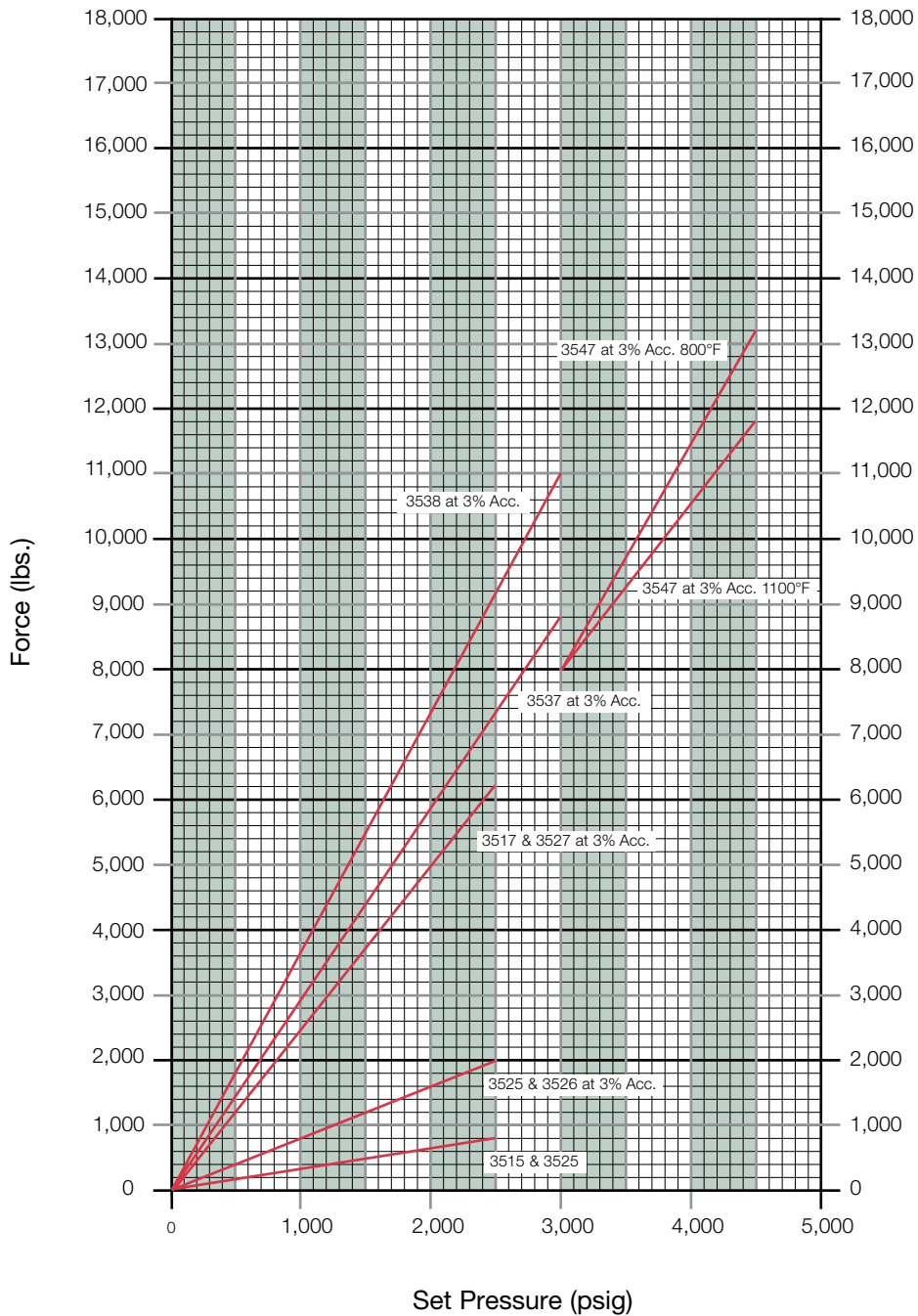

Orifice Capacities

Superheat Correction Factor																	
Total Temp. (°F)	400	450	500	550	600	650	700	750	800	850	900	950	1000	1050	1100	1150	1200
Flowing Pressure (psia)*	Superheat Correction Factor K																
50	0.987	0.957	0.930	0.905	0.882	0.861	0.841	0.823	0.805	0.789	0.774	0.759	0.745	0.732	0.719	0.708	0.696
100	0.998	0.963	0.935	0.909	0.885	0.864	0.843	0.825	0.807	0.790	0.775	0.760	0.746	0.733	0.720	0.708	0.697
150	0.984	0.970	0.940	0.913	0.888	0.866	0.846	0.826	0.808	0.792	0.776	0.761	0.747	0.733	0.721	0.709	0.697
200	0.979	0.977	0.945	0.917	0.892	0.869	0.848	0.828	0.810	0.793	0.777	0.762	0.748	0.734	0.721	0.709	0.698
250	-	0.972	0.951	0.921	0.895	0.871	0.850	0.830	0.812	0.794	0.778	0.763	0.749	0.735	0.722	0.710	0.698
300	-	0.968	0.957	0.926	0.898	0.874	0.852	0.832	0.813	0.796	0.780	0.764	0.750	0.736	0.723	0.710	0.699
350	-	0.968	0.963	0.930	0.902	0.877	0.854	0.834	0.815	0.797	0.781	0.765	0.750	0.736	0.723	0.711	0.699
400	-	-	0.963	0.935	0.906	0.880	0.857	0.836	0.816	0.798	0.782	0.766	0.751	0.737	0.724	0.712	0.700
450	-	-	0.961	0.940	0.909	0.883	0.859	0.838	0.818	0.800	0.783	0.767	0.752	0.738	0.725	0.712	0.700
500	-	-	0.961	0.946	0.914	0.886	0.862	0.840	0.820	0.801	0.784	0.768	0.753	0.739	0.725	0.713	0.701
550	-	-	0.962	0.952	0.918	0.889	0.864	0.842	0.822	0.803	0.785	0.769	0.754	0.740	0.726	0.713	0.701
600	-	-	0.964	0.958	0.922	0.892	0.867	0.844	0.823	0.804	0.787	0.770	0.755	0.740	0.727	0.714	0.702
650	-	-	0.968	0.958	0.927	0.896	0.869	0.846	0.825	0.806	0.788	0.771	0.756	0.741	0.728	0.715	0.702
700	-	-	-	0.958	0.931	0.899	0.872	0.848	0.827	0.807	0.789	0.772	0.757	0.742	0.728	0.715	0.703
750	-	-	-	0.958	0.936	0.903	0.875	0.850	0.828	0.809	0.790	0.774	0.758	0.743	0.729	0.716	0.703
800	-	-	-	0.960	0.942	0.906	0.878	0.852	0.830	0.810	0.792	0.774	0.759	0.744	0.730	0.716	0.704
850	-	-	-	0.962	0.947	0.910	0.880	0.855	0.832	0.812	0.793	0.776	0.760	0.744	0.730	0.717	0.704
900	-	-	-	0.965	0.953	0.914	0.883	0.857	0.834	0.813	0.794	0.777	0.760	0.745	0.731	0.718	0.705
950	-	-	-	0.969	0.958	0.918	0.886	0.860	0.836	0.815	0.796	0.778	0.761	0.746	0.732	0.718	0.705
1000	-	-	-	0.974	0.959	0.923	0.890	0.862	0.838	0.816	0.797	0.779	0.762	0.747	0.732	0.719	0.706
1050	-	-	-	-	0.960	0.927	0.893	0.864	0.840	0.818	0.798	0.780	0.763	0.748	0.733	0.719	0.707
1100	-	-	-	-	0.962	0.931	0.896	0.867	0.842	0.820	0.800	0.781	0.764	0.749	0.734	0.720	0.707
1150	-	-	-	-	0.964	0.936	0.899	0.870	0.844	0.821	0.801	0.782	0.765	0.749	0.735	0.721	0.708
1200	-	-	-	-	0.966	0.941	0.903	0.872	0.846	0.823	0.802	0.784	0.766	0.750	0.735	0.721	0.708
1250	-	-	-	-	0.969	0.946	0.906	0.875	0.848	0.825	0.804	0.785	0.767	0.751	0.736	0.722	0.709
1300	-	-	-	-	0.973	0.952	0.910	0.878	0.850	0.826	0.805	0.786	0.768	0.752	0.737	0.723	0.709
1350	-	-	-	-	0.977	0.958	0.914	0.880	0.852	0.828	0.807	0.787	0.769	0.753	0.737	0.723	0.710
1400	-	-	-	-	0.982	0.963	0.918	0.883	0.854	0.830	0.808	0.788	0.770	0.754	0.738	0.724	0.710
1450	-	-	-	-	0.987	0.968	0.922	0.886	0.857	0.832	0.809	0.790	0.771	0.754	0.739	0.724	0.711
1500	-	-	-	-	0.993	0.970	0.926	0.889	0.859	0.833	0.811	0.791	0.772	0.755	0.740	0.725	0.711
1550	-	-	-	-	-	0.972	0.930	0.892	0.861	0.835	0.812	0.792	0.773	0.756	0.740	0.726	0.712
1600	-	-	-	-	-	0.973	0.934	0.894	0.863	0.836	0.813	0.792	0.774	0.756	0.740	0.726	0.712
1650	-	-	-	-	-	0.973	0.936	0.895	0.863	0.836	0.812	0.791	0.772	0.755	0.739	0.724	0.710
1700	-	-	-	-	-	0.973	0.938	0.895	0.863	0.835	0.811	0.790	0.771	0.754	0.738	0.723	0.709
1750	-	-	-	-	-	0.974	0.940	0.896	0.862	0.835	0.810	0.789	0.770	0.752	0.736	0.721	0.707
1800	-	-	-	-	-	0.975	0.942	0.897	0.862	0.834	0.810	0.788	0.768	0.751	0.735	0.720	0.705
1850	-	-	-	-	-	0.976	0.944	0.897	0.862	0.833	0.809	0.787	0.767	0.749	0.733	0.718	0.704
1900	-	-	-	-	-	0.977	0.946	0.898	0.862	0.832	0.807	0.785	0.766	0.748	0.731	0.716	0.702
1950	-	-	-	-	-	0.979	0.949	0.898	0.861	0.832	0.806	0.784	0.764	0.746	0.729	0.714	0.700
2000	-	-	-	-	-	0.982	0.952	0.899	0.861	0.831	0.805	0.782	0.762	0.744	0.728	0.712	0.698
2050	-	-	-	-	-	0.985	0.954	0.899	0.860	0.830	0.804	0.781	0.761	0.742	0.726	0.710	0.696
2100	-	-	-	-	-	0.988	0.956	0.900	0.860	0.828	0.802	0.779	0.759	0.740	0.724	0.708	0.694
2150	-	-	-	-	-	-	0.956	0.900	0.859	0.827	0.801	0.778	0.757	0.738	0.722	0.706	0.692
2200	-	-	-	-	-	-	0.955	0.901	0.859	0.826	0.799	0.776	0.755	0.736	0.720	0.704	0.690
2250	-	-	-	-	-	-	0.954	0.901	0.858	0.825	0.797	0.774	0.753	0.734	0.717	0.702	0.687
2300	-	-	-	-	-	-	0.953	0.901	0.857	0.823	0.795	0.772	0.751	0.732	0.715	0.699	0.685
2350	-	-	-	-	-	-	0.952	0.902	0.856	0.822	0.794	0.769	0.748	0.729	0.712	0.697	0.682
2400	-	-	-	-	-	-	0.952	0.902	0.855	0.820	0.791	0.767	0.746	0.727	0.710	0.694	0.679
2450	-	-	-	-	-	-	0.951	0.902	0.854	0.818	0.789	0.765	0.743	0.724	0.707	0.691	0.677
2500	-	-	-	-	-	-	0.951	0.902	0.852	0.816	0.787	0.762	0.740	0.721	0.704	0.688	0.674
2550	-	-	-	-	-	-	0.951	0.902	0.851	0.814	0.784	0.759	0.738	0.718	0.701	0.685	0.671
2600	-	-	-	-	-	-	0.951	0.903	0.849	0.812	0.782	0.756	0.735	0.715	0.698	0.682	0.664
2650	-	-	-	-	-	-	0.952	0.903	0.848	0.809	0.779	0.754	0.731	0.712	0.695	0.679	0.664
2700	-	-	-	-	-	-	0.952	0.903	0.846	0.807	0.776	0.750	0.728	0.708	0.691	0.675	0.661
2750	-	-	-	-	-	-	0.953	0.903	0.844	0.804	0.773	0.747	0.724	0.705	0.687	0.671	0.657
2800	-	-	-	-	-	-	0.956	0.903	0.842	0.801	0.769	0.743	0.721	0.701	0.684	0.668	0.653
2850	-	-	-	-	-	-	0.959	0.902	0.839	0.798	0.766	0.739	0.717	0.697	0.679	0.663	0.649
2900	-	-	-	-	-	-	0.963	0.902	0.836	0.794	0.762	0.735	0.713	0.693	0.675	0.659	0.645
2950	-	-	-	-	-	-	-	0.902	0.834	0.790	0.758	0.731	0.708	0.688	0.671	0.655	0.640
3000	-	-	-	-	-	-	-	0.901	0.831	0.786	0.753	0.726	0.704	0.684	0.666	0.650	0.635
3050	-	-	-	-	-	-	-	0.899	0.827	0.782	0.749	0.722	0.699	0.679	0.661	0.645	0.630
3100	-	-	-	-	-	-	-	0.896	0.823	0.777	0.744	0.716	0.693	0.673	0.656	0.640	0.625
3150	-	-	-	-	-	-	-	0.894	0.819	0.772	0.738	0.711	0.688	0.668	0.650	0.634	0.620
3200	-	-	-	-	-	-	-	0.889	0.815	0.767	0.733	0.705	0.682	0.662	0.644	0.628	0.614

Notes:

1. For capacity on superheated steam, multiply saturated steam capacity by correction factor.
2. Convert set pressure from (psig) to flowing pressure (psia) *flowing pressure (psia) = [set pressure (psig) x overpressure] + 14.7

Valve Configuration Code

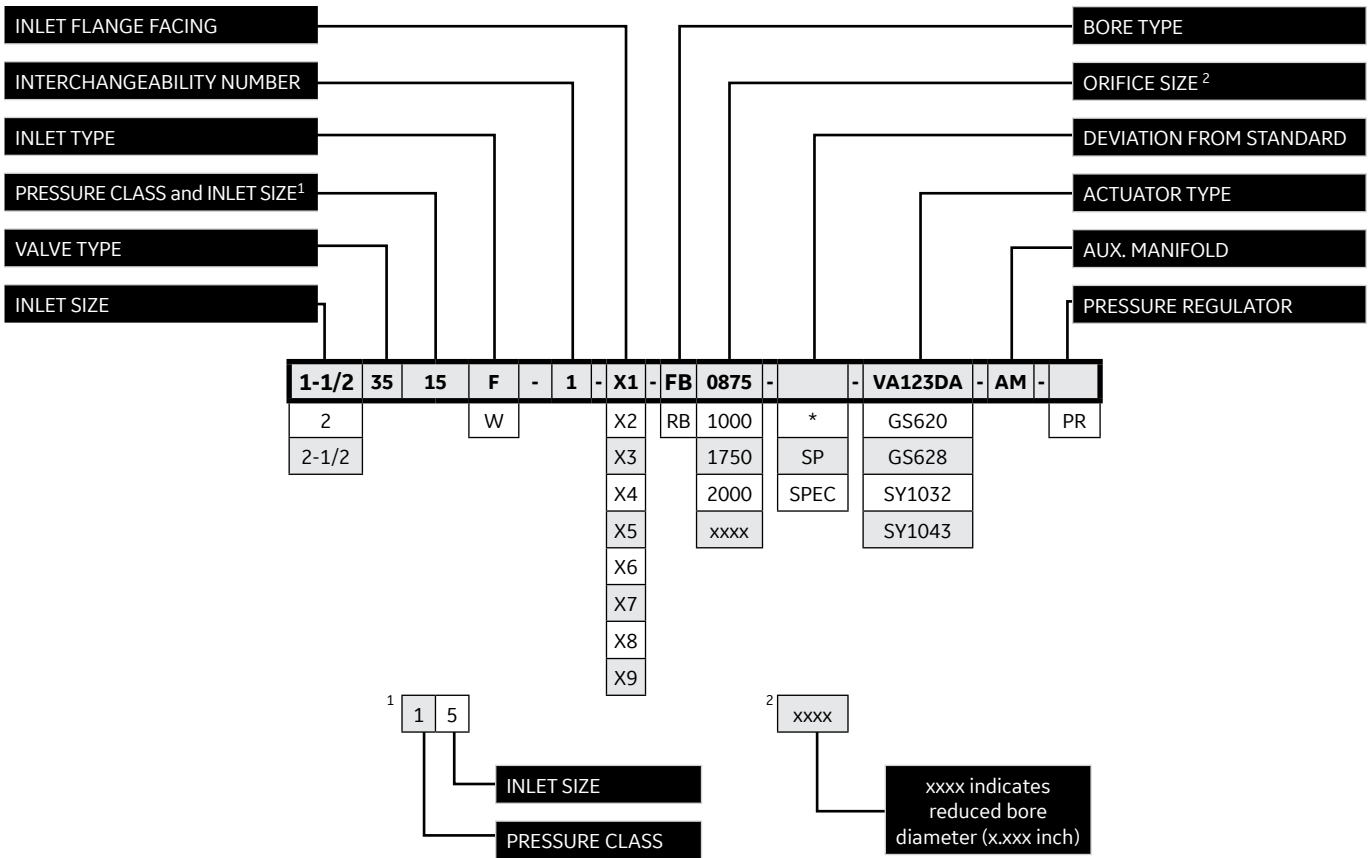

Standard Valve Connection							
Inlet Size		Designation	Orifice Size		Bore Type	Area	
in.	mm		in.	mm		in ²	cm ²
1.50	38.1	5	.88	22.2	FB	0.601	3.877
2.00	50.8	6	1.00	25.4	FB	0.785	5.065
2.50	63.5	7	1.75	44.5	FB	2.405	15.516
2.50	63.5	7	2.00	50.8	FB	3.142	20.271
1.50	38.1	5, 6, 7	Reduced bore size ¹		RB	Variable	
2.00	50.8	5, 6, 7	Reduced bore size ¹		RB	Variable	
2.50	63.5	5, 6, 7	Reduced bore size ¹		RB	Variable	

Pressure Class Flanged Inlet	
Designation	Class
1	1500#
2	2500#
Buttweld Inlet	
2	2658# LTD
3	3092# LTD
4	4500# LTD

Note:

1. Reduced bore diameter indicated in valve code as represented by xxxx above.

Inlet Type	
Designation	Type
F	Flanged
W	Buttweld

Bore Type	
Designation	Type
FB	Full bore
RB	Reduced bore

Inlet Flange Facing	
Designation	Facing
X1	Raised face spiral serrated
X2	Raised face smooth
X3	Ring joint
X4	Large tongue
X5	Large groove
X6	Small tongue
X7	Small groove
X8	Large female
X9	Large male

Interchangeability Number	
Designation	Valve Type
1	Primary design release

Actuator Type	
Designation	Type
VA123DA	Ledeen: VA123DA
GS620	Ledeen: GS620
GS628	Ledeen: GS628
SY1032	Ledeen: SY1032
SY1043	Ledeen: SY1043

How to Order a 3500 Safety Valve

Ordering a 3500 Safety Valve	
Specify:	
Type of Application	Valve Supplemental Data
a) Superheater _____	a) Special Cleaning _____
b) Other _____ (identify)	b) Special Boxing _____
Applicable ASME Code	c) Export Boxing _____
a) Section I - Power Boiler	d) Special Painting _____
b) Section VIII - Pressure Vessels	Available Air [(40-120 psig) (2.76-8.27 barg)]
C) Non Code	Max. _____ psig _____ barg
System Parameters	Min. _____ psig _____ barg
a) Design Pressure _____ psig _____ barg	Electrical Requirements
b) Design Temperature _____ °F _____ °C	AC _____
c) Operating Pressure _____ psig _____ barg	Hz _____
d) Operating Temperature _____ °F _____ °C	DC _____
Valve Specifications	Control Preference
a) Valve Set Pressure _____ psig _____ barg	2537 Control Station _____
b) Allowable Overpressure on Valve _____ percent	2539 Controller _____
c) Required Relieving Capacity _____ lb/hr _____ kg/hr	Transmitter Controller _____
d) Buttweld Valves	DCS _____
Inlet Size _____	Other (specify) _____
Inlet Specifications _____	Safety Valve Information
Outlet Size and Flange Rating _____	a) Total Generating Capacity of the Boiler
e) Flanged Valves	b) Drum Safety Valve Capacities
Inlet Size and Flange Rating _____	c) Superheater Safety Valve Capacities
Outlet Size and Flange Rating _____	d) Drum Operating Pressure
f) Other Type Connections Other Than	e) Superheater Operating Pressure
Buttweld or Flange _____	f) Set Pressure of Low Set Drum Safety Valve
g) Special Codes or Standards _____	g) Set Pressure of Low Set Superheater Safety Valve
h) Model and Manufacturer of Isolation Gate Valve (if any) _____	
i) Model No. and Nameplate data of valve being replaced _____	

DIRECT SALES OFFICE LOCATIONS

AUSTRALIA

Brisbane:
Phone: +61-7-3001-4319
Fax: +61-7-3001-4399

Perth:
Phone: +61-8-6595-7018
Fax: +61-8-6595-7299

Melbourne:
Phone: +61-3-8807-6002
Fax: +61-3-8807-6577

BELGIUM
Phone: +32-2-344-0970
Fax: +32-2-344-1123

BRAZIL
Phone: +55-19-2104-6900

CHINA
Phone: +86-10-5738-8888
Fax: +86-10-5918-9707

FRANCE
Courbevoie
Phone: +33-1-4904-9000
Fax: +33-1-4904-9010

GERMANY
Ratingen
Phone: +49-2102-108-0
Fax: +49-2102-108-111

INDIA
Mumbai
Phone: +91-22-8354790
Fax: +91-22-8354791

New Delhi
Phone: +91-11-2-6164175
Fax: +91-11-5-1659635

ITALY

Phone: +39-081-7892-111
Fax: +39-081-7892-208

JAPAN

Tokyo
Phone: +81-03-6871-9008
Fax: +81-03-6890-4620

KOREA

Phone: +82-2-2274-0748
Fax: +82-2-2274-0794

MALAYSIA

Phone: +60-3-2161-0322
Fax: +60-3-2163-6312

MEXICO

Phone: +52-55-3640-5060

THE NETHERLANDS

Phone: +31-15-3808666

RUSSIA

Veliky Novgorod
Phone: +7-8162-55-7898
Fax: +7-8162-55-7921

Moscow

Phone: +7 495-585-1276
Fax: +7 495-585-1279

SAUDI ARABIA

Phone: +966-3-341-0278
Fax: +966-3-341-7624

SINGAPORE

Phone: +65-6861-6100
Fax: +65-6861-7172

SOUTH AFRICA

Phone: +27-11-452-1550
Fax: +27-11-452-6542

SOUTH & CENTRAL

AMERICA AND THE CARIBBEAN
Phone: +55-12-2134-1201
Fax: +55-12-2134-1238

SPAIN

Phone: +34-93-652-6430
Fax: +34-93-652-6444

UNITED ARAB EMIRATES

Phone: +971-4-8991-777
Fax: +971-4-8991-778

UNITED KINGDOM

Bracknell
Phone: +44-1344-460-500
Fax: +44-1344-460-537

Skelmersdale

Phone: +44-1695-526-00
Fax: +44-1695-526-01

UNITED STATES

Jacksonville, Florida
Phone: +1-904-570-3409

Deer Park, Texas

Phone: +1-281-884-1000
Fax: +1-281-884-1010

Houston, Texas

Phone: +1-281-671-1640
Fax: +1-281-671-1735

bhge.com

*Denotes a trademark of Baker Hughes, a GE company, LLC.

Other company names and product names used in this document are the registered trademarks or trademarks of their respective owners.

© 2018 Baker Hughes, a GE company LLC - All rights reserved.

Baker Hughes, a GE company, LLC and its affiliates ("BHGE") provides this information on an "as is" basis for general information purposes and believes it to be accurate as of the date of publication. BHGE does not make any representation as to the accuracy or completeness of the information and makes no warranties of any kind, specific, implied or oral, to the fullest extent permissible by law, including those of merchantability and fitness for a particular purpose or use. BHGE hereby disclaims any and all liability for any direct, indirect, consequential or special damages, claims for lost profits, or third party claims arising from the use of the information, whether a claim is asserted in contract, tort, or otherwise. The BHGE logo is a trademark of Baker Hughes, a GE company LLC. GE and the GE monogram are trademarks of the General Electric Company used under trademark license.

GEA20253C 09/2018

**BAKER
HUGHES**
a GE company

