

Consolidated* **1900/P** Series Safety Relief Valve

Maintenance Manual



THESE INSTRUCTIONS PROVIDE THE CUSTOMER/OPERATOR WITH IMPORTANT PROJECT-SPECIFIC REFERENCE INFORMATION IN ADDITION TO THE CUSTOMER/OPERATOR'S NORMAL OPERATION AND MAINTENANCE PROCEDURES. SINCE OPERATION AND MAINTENANCE PHILOSOPHIES VARY, GE (GENERAL ELECTRIC COMPANY AND ITS SUBSIDIARIES AND AFFILIATES) DOES NOT ATTEMPT TO DICTATE SPECIFIC PROCEDURES, BUT TO PROVIDE BASIC LIMITATIONS AND REQUIREMENTS CREATED BY THE TYPE OF EQUIPMENT PROVIDED.

THESE INSTRUCTIONS ASSUME THAT OPERATORS ALREADY HAVE A GENERAL UNDERSTANDING OF THE REQUIREMENTS FOR SAFE OPERATION OF MECHANICAL AND ELECTRICAL EQUIPMENT IN POTENTIALLY HAZARDOUS ENVIRONMENTS. THEREFORE, THESE INSTRUCTIONS SHOULD BE INTERPRETED AND APPLIED IN CONJUNCTION WITH THE SAFETY RULES AND REGULATIONS APPLICABLE AT THE SITE AND THE PARTICULAR REQUIREMENTS FOR OPERATION OF OTHER EQUIPMENT AT THE SITE.

THESE INSTRUCTIONS DO NOT PURPORT TO COVER ALL DETAILS OR VARIATIONS IN EQUIPMENT NOR TO PROVIDE FOR EVERY POSSIBLE CONTINGENCY TO BE MET IN CONNECTION WITH INSTALLATION, OPERATION OR MAINTENANCE. SHOULD FURTHER INFORMATION BE DESIRED OR SHOULD PARTICULAR PROBLEMS ARISE WHICH ARE NOT COVERED SUFFICIENTLY FOR THE CUSTOMER/OPERATOR'S PURPOSES THE MATTER SHOULD BE REFERRED TO GE.

THE RIGHTS, OBLIGATIONS AND LIABILITIES OF GE AND THE CUSTOMER/OPERATOR ARE STRICTLY LIMITED TO THOSE EXPRESSLY PROVIDED IN THE CONTRACT RELATING TO THE SUPPLY OF THE EQUIPMENT. NO ADDITIONAL REPRESENTATIONS OR WARRANTIES BY GE REGARDING THE EQUIPMENT OR ITS USE ARE GIVEN OR IMPLIED BY THE ISSUE OF THESE INSTRUCTIONS.

THESE INSTRUCTIONS ARE FURNISHED TO THE CUSTOMER/OPERATOR SOLELY TO ASSIST IN THE INSTALLATION, TESTING, OPERATION, AND/OR MAINTENANCE OF THE EQUIPMENT DESCRIBED. THIS DOCUMENT SHALL NOT BE REPRODUCED IN WHOLE OR IN PART WITHOUT THE WRITTEN APPROVAL OF GE.

Conversion Table

All the United States Customary System (USCS) values are converted to metric values using the following conversion factors:		
USCS Unit	Conversion Factor	Metric Unit
in.	25.4	mm
lb.	0.4535924	kg
in ²	6.4516	cm ²
ft ³ /min	0.02831685	m ³ /min
gal/min	3.785412	L/min
lb/hr	0.4535924	kg/hr
psig	0.06894757	barg
ft lb	1.3558181	Nm
°F	5/9 (°F-32)	°C

Note: Multiply USCS value with conversion factor to get metric value.

NOTICE
For valve configurations not listed in this manual, please contact your local Green Tag* Center for assistance.

Table of Contents

Section	Subject	Page No
I.	Product Safety Sign and Label System.....	5
II.	Safety Alerts.....	6
III.	Safety Notice.....	7
IV.	Warranty Information.....	8
V.	Terminology for Safety Relief Valves.....	8
VI.	Handling and Storage.....	10
VII.	Pre-Installation and Installation Instructions.....	10
VIII.	Introduction.....	11
IX.	GE's Consolidated 1900/P Series Safety Relief Valves.....	12
	A. Conventional Valve.....	12
	B. Standard Cap Types.....	13
	C. Bellows Valve (P1 only).....	14
X.	Operating Principle.....	14
XI.	General Planning for Maintenance.....	15
XII.	Recommended Installation Practices.....	15
XIII.	Disassembly of 1900/P Series Safety Relief Valves.....	16
XIV.	Maintenance Instructions.....	17
	A. Machining of Seat Nozzle.....	17
	B. Lapping.....	18
	C. Reconditioning of Ring Laps.....	18
	D. General Lapping Comments.....	18
	E. Nozzle Lapping.....	18
	F. Thermodisc* Disc Lapping.....	19
XV.	Inspection and Part Replacement.....	19
XVI.	Reassembly 1900/P Series Safety Relief Valves.....	22
	A. Reassembly of the Valve.....	22
	B. Checking Lift on D and E Valves.....	24
	C. Limit Washer Length.....	25
XVII.	Setting and Testing.....	26
	A. Setting the Valve.....	26
	B. Back Pressure Compensation.....	26
	C. Blowdown.....	26
	D. Seat Leakage.....	27
	E. Recommended Back Pressure Testing.....	27
	F. System Hydrostatic Testing.....	27
	G. Adjusting Ring Settings.....	28

Table of Contents

Section	Subject	Page No
XVIII.	Troubleshooting Guide for Safety Relief Valve.....	29
XIX.	1900/P Series PRV Options.....	29
	A. Cap and Weather Shield Options.....	29
XX.	Maintenance Tools and Supplies.....	31
	A. Pin Spanner Wrenches.....	31
	B. Inside Snap Ring Pliers.....	31
	C. Lap Rings.....	32
	D. Lap Plate.....	32
	E. Lapping Compounds.....	32
XXI.	Replacement Parts Planning.....	33
	A. Service Parts Inventory Planning.....	33
	B. Ordering Essentials.....	33
XXII.	Genuine Consolidated Parts.....	34
XXIII.	Recommended Spare Parts.....	35
XXIV.	Manufacture's Field Service, Repair and Training Program.....	36
	A. Field Service.....	36
	B. Factory Repair Facilities.....	37
	C. Maintenance Training.....	37

I. Product Safety Sign and Label System

If and when required, appropriate safety labels have been included in the rectangular margin blocks throughout this manual. Safety labels are vertically oriented rectangles as shown in the *representative examples* (below), consisting of three panels encircled by a narrow border. The panels can contain four messages which communicate:

- The level of hazard seriousness
- The nature of the hazard
- The consequence of human, or product, interaction with the hazard.
- The instructions, if necessary, on how to avoid the hazard.

The top panel of the format contains a signal word (DANGER, WARNING, CAUTION or ATTENTION) which communicates the level of hazard seriousness.

The center panel contains a pictorial which communicates the nature of the hazard, and the possible consequence of human or product interaction with the hazard. In some instances of human hazards the pictorial may, instead, depict what preventive measures to take, such as wearing protective equipment.

The bottom panel may contain an instruction message on how to avoid the hazard. In the case of human hazard, this message may also contain a more precise definition of the hazard, and the consequences of human interaction with the hazard, than can be communicated solely by the pictorial.

①
DANGER — Immediate hazards which **WILL** result in severe personal injury or death.

②
WARNING — Hazards or unsafe practices which **COULD** result in severe personal injury or death.

③
CAUTION — Hazards or unsafe practices which **COULD** result in minor personal injury.

④
ATTENTION — Hazards or unsafe practices which **COULD** result in product or property damage.



II. Safety Alerts

Read - Understand - Practice

Danger Alerts

A DANGER alert describes actions that may cause severe personal injury or death. In addition, it may provide preventive measures to avoid severe personal injury or death.

DANGER alerts are not all-inclusive. GE cannot know all conceivable service methods nor evaluate all potential hazards. Dangers include:

- High temperature/pressure can cause injury. Ensure all system pressure is absent before repairing or removing valves.
- Do not stand in front of a valve outlet when discharging. STAND CLEAR OF VALVE to avoid exposure to trapped, corrosive media.
- Exercise extreme caution when inspecting a pressure relief valve for leakage.
- Allow the system to cool to room temperature before cleaning, servicing, or repairing. Hot components or fluids can cause severe personal injury or death.
- Always read and comply with safety labels on all containers. Do not remove or deface container labels. Improper handling or misuse could result in severe personal injury or death.
- Never use pressurized fluids/gas/air to clean clothing or body parts. Never use body parts to check for leaks, flow rates, or areas. Pressurized fluids/gas/air injected into or near the body can cause severe personal injury or death.
- It is the owner's responsibility to specify and provide protective wear to protect persons from pressurized or heated parts. Contact with pressurized or heated parts can result in severe personal injury or death.

- Do not work or allow anyone under the influence of intoxicants or narcotics to work on or around pressurized systems. Workers under the influence of intoxicants or narcotics are a hazard to themselves and other employees. Actions taken by an intoxicated employee can result in severe personal injury or death to themselves or others.
- Always perform correct service and repair. Incorrect service and repair can result in product or property damage or severe personal injury or death.
- Always use the correct tool for a job. The misuse of a tool or the use of an improper tool can result in personal injury, damage to product or property.
- Ensure the proper "health physics" procedures are followed, if applicable, before starting operation in a radioactive environment.

Caution Alerts

A CAUTION alert describes actions that may result in a personal injury. In addition, they may describe preventive measures that must be taken to avoid personal injury. Cautions include:

- Heed all service manual warnings. Read installation instructions before installing valve(s).
- Wear hearing protection when testing or operating valves.
- Wear appropriate eye and clothing protection.
- Wear protective breathing apparatus to protect against toxic media.

III. Safety Notice

⚠ WARNING



All potential hazards may not be covered in this manual.

⚠ CAUTION



Wear necessary protective equipment to avoid possible personal injury.

⚠ ATTENTION



Improper tools or improper use of right tools could result in personal injury or product damage.

Proper installation and start-up is essential to the safe and reliable operation of all valve products. The relevant procedures recommended by GE, and described in these instructions, are effective methods of performing the required tasks.

It is important to note that these instructions contain various “safety messages” which should be carefully read in order to minimize the risk of personal injury, or the possibility that improper procedures will be followed which may damage the involved GE product, or render it unsafe. It is also important to understand that these “safety messages” are not exhaustive. GE can not possibly know, evaluate, and advise any customer of all of the conceivable ways in which tasks might be performed, or of the possible hazardous consequences of each way. Consequently, GE has not undertaken any such broad evaluation and, thus, anyone who uses a procedure and/or tool, which is not recommended by GE, or deviates from GE recommendations, must be thoroughly satisfied that neither personal safety, nor valve safety, will be jeopardized by the method and/or tools selected. Contact your local Green Tag Center if there are any questions relative to tools/methods.

The installation and start-up of valves and/or valve products may involve proximity to fluids at extremely high pressure and/or temperature. Consequently, every precaution should be taken to prevent injury to personnel during the performance of any procedure. These precautions should consist of, but are not limited to, ear drum protection, eye protection, and the use of protective clothing, (i.e., gloves, etc.) when personnel are in, or around, a valve work area. Due to the various circumstances and conditions in which these operations may be performed on GE products, and the possible hazardous consequences of each way, GE can not possibly evaluate all conditions that might injure personnel or equipment. Nevertheless, GE does offer certain Safety Precautions, listed in Section II, for customer information only.

It is the responsibility of the purchaser or user of GE valves/equipment to adequately train all personnel who will be working with the involved valves/equipment. For more information on training schedules, please contact your local Green Tag Center or GE’s Consolidated Training Manager at +1 (281) 542-3646. Further, prior to working with the involved valves/equipment, personnel who are to perform such work should become thoroughly familiar with the contents of these instructions.

IV. Warranty Information

Warranty Statement:¹ GE warrants that its products and work will meet all applicable specifications and other specific product and work requirements (including those of performance), if any, and will be free from defects in material and workmanship

CAUTION: Defective and nonconforming items must be held for GE's inspection and returned to the original F.O.B point upon request.

Incorrect Selection or Misapplication of Products: GE cannot be responsible for customer's incorrect selection or misapplication of our products.

Unauthorized Repair work: GE has not authorized any non-GE-affiliated repair companies, contractors or individuals to perform warranty repair service on new products or field repaired products of its manufacture. Therefore customers contracting such repair services from unauthorized sources must do so at their own risk.

Unauthorized Removal of Seals: All new valves and valves repaired in the field by GE's Field Service team are sealed to assure the customer of our guarantee against defective workmanship. Unauthorized removal and/or breakage of this seal will negate our warranty.

Note 1 Refer to GE's Standard Terms of Sale for complete details on warranty and limitation of remedy and liability.

V. Terminology for Safety Relief Valves (paraphrased from PTC 25.3)

The basic definitions of pressure relief valves are given in ANSI B95.1, Terminology for Pressure Relief Devices; ASME PTC 25.3, Performance Test Code for Safety and Relief Valves; and API RP 520, Design and Installation of Pressure Relieving Systems in Refineries.

- **Accumulation**

See Overpressure

- **Back Pressure**

The pressure at the discharge side of the valve.

- **Superimposed Back Pressure**

The pressure in the discharge header before the valve opens

- Constant Superimposed: This type of back pressure remains essentially at a fixed value (constant) and exists (superimposed) continuously prior to and during the opening of the valve.
- Variable Superimposed: This type of back pressure varies or changes over a range from a minimum to a maximum, or vice versa. The actual back pressure at any specific time depends on conditions in the piping system to which the outlet of the valve is connected.

- **Built-up Back Pressure**

The pressure which develops at the valve outlet as a result of flow after the valve is opened.

CAUTION

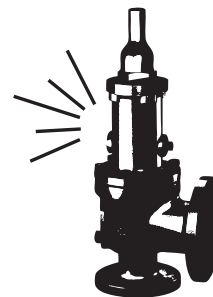

Defective and nonconforming items must be inspected by GE

CAUTION



Removal and/or breakage of seal will negate our warranty.

V. Terminology for Safety Relief Valves (Contd.)

- **Blowdown**

Blowdown is the difference between set pressure and resetting pressure. It is generally expressed as a percentage of set pressure.
- **Chatter**

Chatter is abnormal, rapid reciprocating motion of the movable parts of a safety valve in which the disc contacts the seat.
- **Closing pressure**

Closing pressure is the point at which the valve recloses.
- **Cold Differential Set Pressure (CDS)**

This is the test pressure at which the valve is adjusted to open on the test stand. This pressure includes the corrections for temperature and/or back pressure service conditions. Nameplate shows “cold set press” (see Figure 31).
- **Disc**

A disc is the pressure containing movable element of a valve which affects closure.
- **Flutter**

Flutter is abnormal, reciprocating motion of the movable parts of a valve in which the disc does not contact the seat.
- **Leakage**

See “Seat Leakage”.
- **Lift**

Lift is the disc rise when a valve is open.
- **Maximum Allowable Working Pressure (MAWP)**

The maximum pressure permissible in a vessel at the design temperature.
- **Nozzle**

A nozzle is the pressure-containing element which consists of the inlet flow passage (orifice) and includes the fixed portion of the seat.
- **Operating Pressure**

The normal pressure required to operate the vessel or system. A suitable margin must be provided between the operating and the valve set pressure.
- **Operating and Set Pressure-Differential**

Valves in process service will generally give best results if the operating pressure does not exceed 90 percent of the set pressure. On pump and compressor discharge lines, however, the differential required between the operating and set pressures may be greater because of pressure pulsations coming from a reciprocating piston. It is recommended that the valve be set as high above the operating pressure as possible.
- **Orifice**

The orifice is the minimum cross-sectional area of the controlling nozzle bore.
- **Overpressure**

Overpressure is any pressure in excess of the set pressure, usually expressed as a percentage of set pressure. For certification, accumulation is the percent of overpressure at which the valve is to be fully open as specified by the ASME Code.
- **Pressure Relief Valve**

A pressure relief valve is an automatic pressure relieving device actuated by upstream pressure. A pressure relief valve is designed to open to prevent a rise of system pressure above a specified value and to reclose after normal conditions have been restored.

A pressure relief valve is a two-chamber component having primary and secondary zones. Each chamber has different design criteria (i.e., pressure and temperature). The nozzle and disc are the primary members. The base and bonnet are the secondary members.
- **Rated Capacity**

This is the rated flow at an authorized percent accumulation permitted by the applicable Code. Rated capacity is generally expressed in pounds per hour (lbs/hr) or kg/hr for vapors; standard cubic feet per minute (SCFM) or m³/min for gases; and in gallons per minute (GPM) or L/min for liquids.
- **Relief Valve**

A pressure relief valve which opens in proportion to overpressure. A relief valve is used primarily for liquid service.
- **Reseating Pressure**

See closing pressure.
- **Safety Valve**

A pressure relief valve characterized by rapid full opening or pop action. It is used for gas or vapor service.
- **Safety Relief Valve**

A pressure relief valve that may be used as either a safety or relief valve, depending upon the application.
- **Seat**

The seat is the junction between the nozzle which is fixed and the disc which moves against the nozzle to obtain closure.

V. Terminology for Safety Relief Valves (Contd.)

- **Seat Leakage**

Seat leakage test pressure is the specified inlet static pressure at which a quantitative seat leakage test is performed in accordance with a standard procedure.

- **Set Pressure**

Set pressure is the inlet pressure at which the valve has been adjusted to open under service conditions.

For gas and vapor service - when the valve pops.

For liquid service - when the valve begins to discharge a continuous stream.

- **Simmer**

Characterized by the audible/visual passage of a fluid across the seating surfaces just prior to opening. The difference between this start to open pressure and the set pressure is simmer.

For gas service valves, simmer is leakage just prior to opening.

For liquid service valves, simmer is the noncontinuous flow (drops) just prior to becoming continuous.

- **Valve Trim**

Includes the disc and nozzle.

VI. Handling and Storage

1. Each valve should be carefully inspected after uncrating to be sure the valve has not been damaged during transit.
2. Flanged valves, either crated or skidmounted, should always be kept with the inlet flange down, i.e. never laid on their side, to prevent misalignment and damage to internals.
3. Valves should be stored in a dry environment to protect them from the weather. They should not be removed from the skids or crates until immediately prior to installation.



VII. Pre - Installation and Installation Instructions

1. Flange protectors and sealing plugs should not be removed until the valve is ready to be bolted into the installation, both inlet and outlet. Meticulous care should be exercised to prevent dirt and other foreign materials from entering the inlet and outlet ports before installation.
2. Valves, either crated or uncrated, should never be subjected to sharp impact. This would be most likely to occur while unloading or otherwise moving with a fork lift truck. While hoisting to the installation, care should be exercised to prevent bumping valve.
3. Uncrated valves should be moved or hoisted by wrapping chain or sling around discharge neck, then around upper bonnet structure in such manner as will ensure the valve is in vertical position during lift, i.e., not lifted in horizontal position.

Caution: Never lift the full weight of the valve by the lifting lever (if so equipped).



VIII. Introduction

Design Features

GE's Consolidated 1900/P Series Steam Internals (conventional or bellows) pressure relief valve is a precision machined device and operates on the force balance principle.

Types 1900/P1 closed bonnet and P3 slotted bonnet valves have been designed for steam service in accordance with ASME Code Section I and VIII. Both types come ready for application and should be handled carefully through receiving, handling, storage and installation.

Safety valves in organic fluid vaporizer service are totally enclosed and do not have a lifting lever.

Reliable performance and easy maintenance procedures are characteristics of those valves when properly installed in applications suitable for their design.

Seat Tightness - Thermodisc*

When the valve closes, a Thermodisc seat compensates for temperature gradient around the seating surface.

High Nozzle Guide

Nozzle is guided in the base as close as possible to the nozzle seat.

Low Spindle Bearing

Valve has a low spindle bearing point, assuring proper alignment and load distribution at the seating surface. This prevents the disc from sliding across the seat on opening and closing.

Simple Blowdown Adjustment

Single blowdown ring design permits ease of adjustment. Proper blowdown can be attained by positioning the ring in accordance with Table 11 (Section XVII)



IX. Consolidated 1900/P Series Safety Relief Valves

A. Conventional Valve

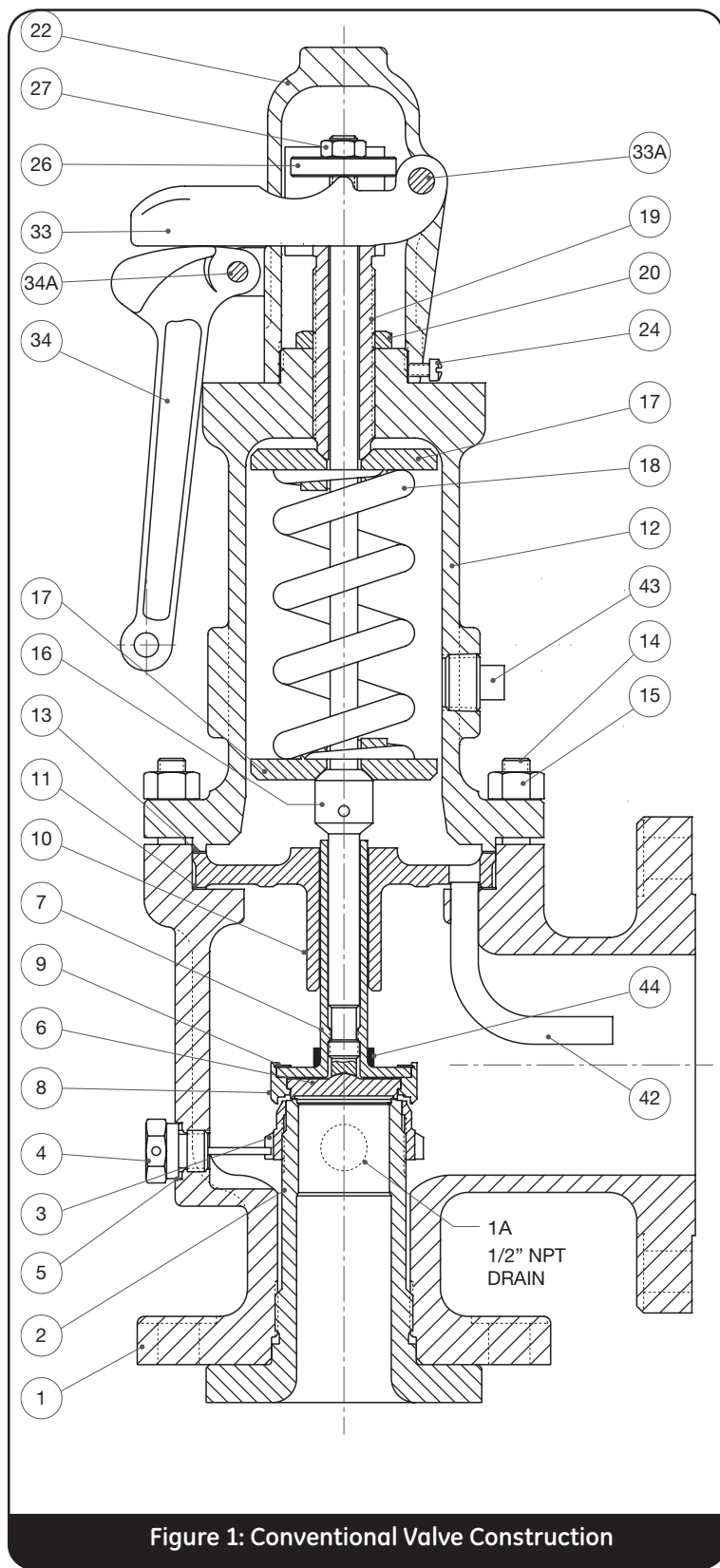

Part No.	Nomenclature
1	Base
2	Nozzle
3	Adjusting Ring
4	Adjusting Ring Pin
5	Adjusting Ring Pin Gasket
6	Disc
7	Disc Holder
8	Holder Ring
9	Holder Ring Retainer
10	Guide
11	Guide Gasket
12	Bonnet
13	Bonnet Gasket (P1 Only)
14	Base Stud
15	Stud Nut
16	Spindle
17	Spring Washer
18	Spring
19	Adjusting Screw
20	Adjusting Screw Nut
22	Plain Cap
24	Cap Set Screw
26	Release Nut
27	Release Locknut
33	Top Lever
33A	Top Lever Pin
34	Drop Lever
34A	Drop Lever Pin
42	Eductor Tube (P1 Only)
43	Bonnet Plug
44	Limit Washer (D-2 & E-2)

IX. (Contd.)

B. Standard Cap Types

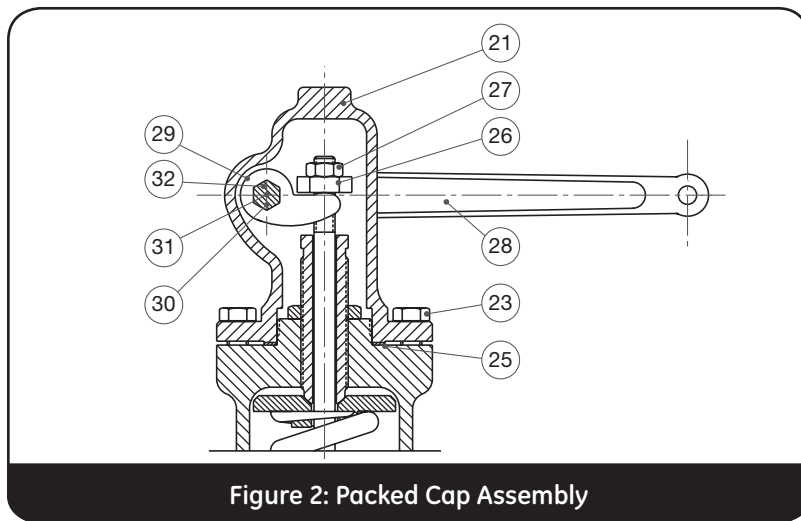

Figure 2: Packed Cap Assembly

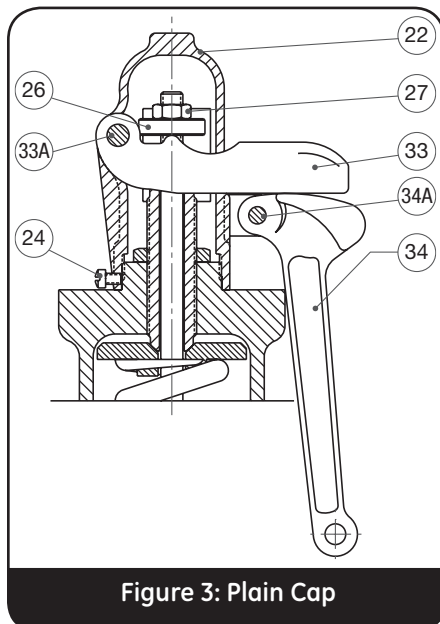

Figure 3: Plain Cap

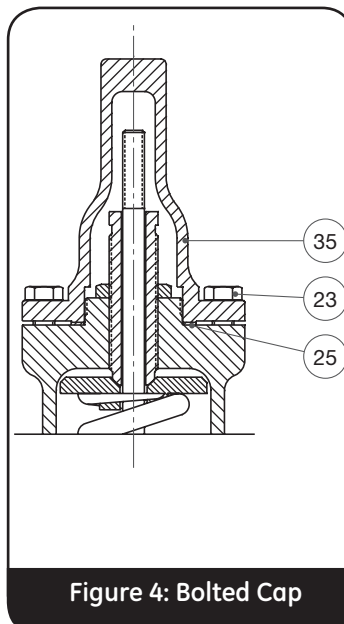

Figure 4: Bolted Cap

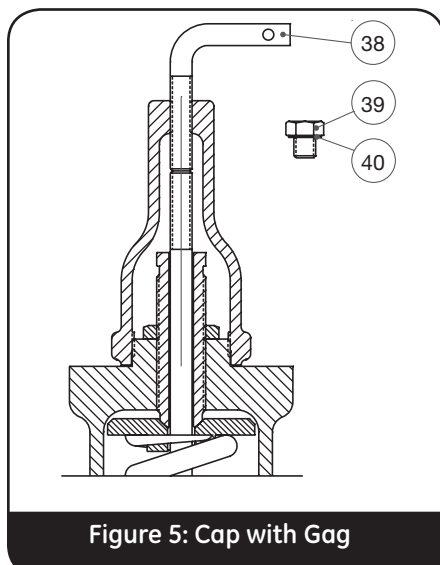

Figure 5: Cap with Gag

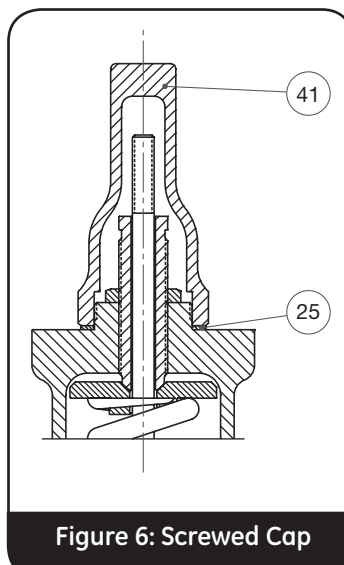
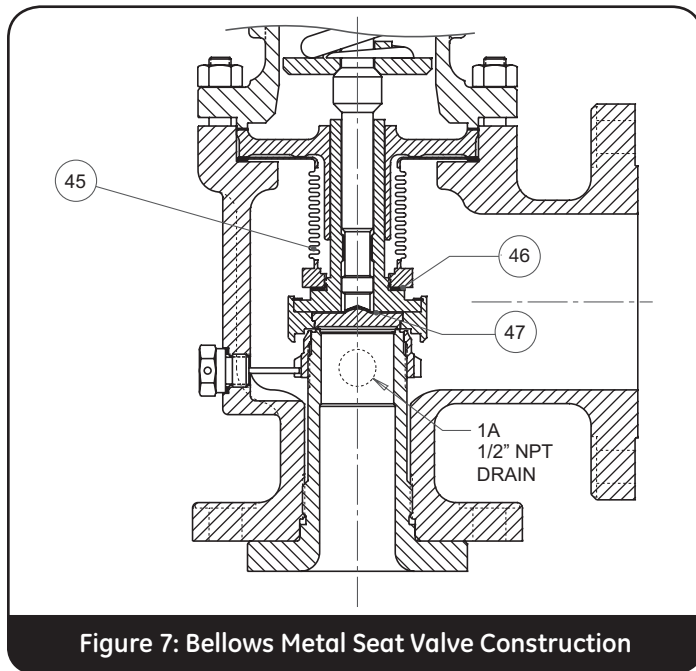

Figure 6: Screwed Cap

Part No.	Nomenclature
Packed Cap Assembly	
21	Packed Cap
23	Cap Screw
25	Cap Gasket (P1 Only)
26	Release Nut
27	Release Locknut
28	Lever
29	Lifting Fork
30	Lever Shaft
31	Packing
32	Packing Nut
Plain Cap Assembly	
22	Plain Cap
24	Cap Set Screw
26	Release Nut
27	Release Locknut
33	Top Lever
33A	Top Lever Pin
34	Drop Lever
34A	Drop Lever Pin
Bolted Cap Assembly	
35	Bolted Cap
23	Cap Screw
25	Cap Gasket (P1 Only)
Gag Assembly	
38	Gag Bolt
39	Sealing Plug
40	Sealing Plug Gasket
Screwed Cap Assembly	
41	Screwed Cap
25	Cap Gasket (P1 Only)

IX. (Contd.)

C. Bellows Valve (P1 Only)



Part No.	Nomenclature
45	Bellows
	Bellows Nut
	Bellows Flange
46	Bellows Gasket
47	Seal Plate

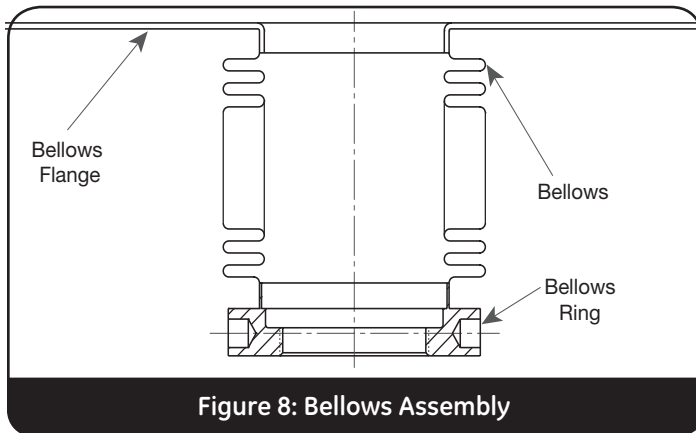

X. Operating Principle

GE's Consolidated 1900/P Series steam internals pressure relief valve is an automatic pressure actuated relieving device suitable for use either as a safety valve or safety relief valve depending on the application.

XI. General Planning for Maintenance

This manual provides plans for inspection and repair of Consolidated 1900/P series steam internals pressure relief valves. The requirements of this manual are considered minimum and do not relieve the user of the responsibility of applicable codes, standards and guides, including all safety regulations having

jurisdiction over the installation.

Preventative maintenance should be practiced. At regular intervals each valve should be removed, disassembled, inspected, refurbished and tested to the customer's requirements.

XII. Recommended Installation Practices

Consolidated Pressure Relief Valves are checked, set and adjusted at the factory.

Piping (systems) is the responsibility of the user. One source of information is ANSI B31.1 Power Piping, Appendix II, "Non-mandatory Rules for the Design of Safety Valve Installations" in steam service.

Valves in organic fluid vaporizer service require a closed discharge piping system.

Piping should be as short as possible and in perfect alignment. Pressure relief valves should be mounted to provide adequate access 360° around the valve plus overhead room to permit removal for testing and maintenance. A pressure relief valve must never be installed in any position except the vertical position and preferably never on the outlet side of an elbow. No stop valve should be placed between the pressure vessel and its pressure relief valve except as permitted by applicable Codes. If a stop valve is located between the pressure vessel and a pressure relief valve, the stop valve shall have a minimum inside diameter equal to or greater than the nominal inside diameter of the pressure relief valve inlet. The inlet piping must be clean before installation.

The discharge piping size must never be less than the valve outlet size.

For conventional valves, GE recommends that the discharge piping be designed to limit the back pressure to 10 percent of the set pressure. GE recommends a bellows valve (see Consolidated SRV-1 for applicable capacity factor).

When gags are used in conjunction with setting valves installed on the boiler, they should be installed after the boiler is at operating temperature.

When a valve is equipped with a lifting lever, the lever should be positioned to avoid accidental contact by other equipment or personnel, which might cause valve to lift accidentally.

Steam service valve body drain must be piped to a safe area. If left plugged, condensate will collect inside the valve body. If left open, hot water can escape and present a hazard to personnel near the valve. Preferably the drain connections (body, elbow and drip pan) should be piped separately - not main-folded - because of the tendency of small pipes to plug with rust.

When installing bellows valves, the bonnet vent plug must be removed and vented (piped) to a safe area.

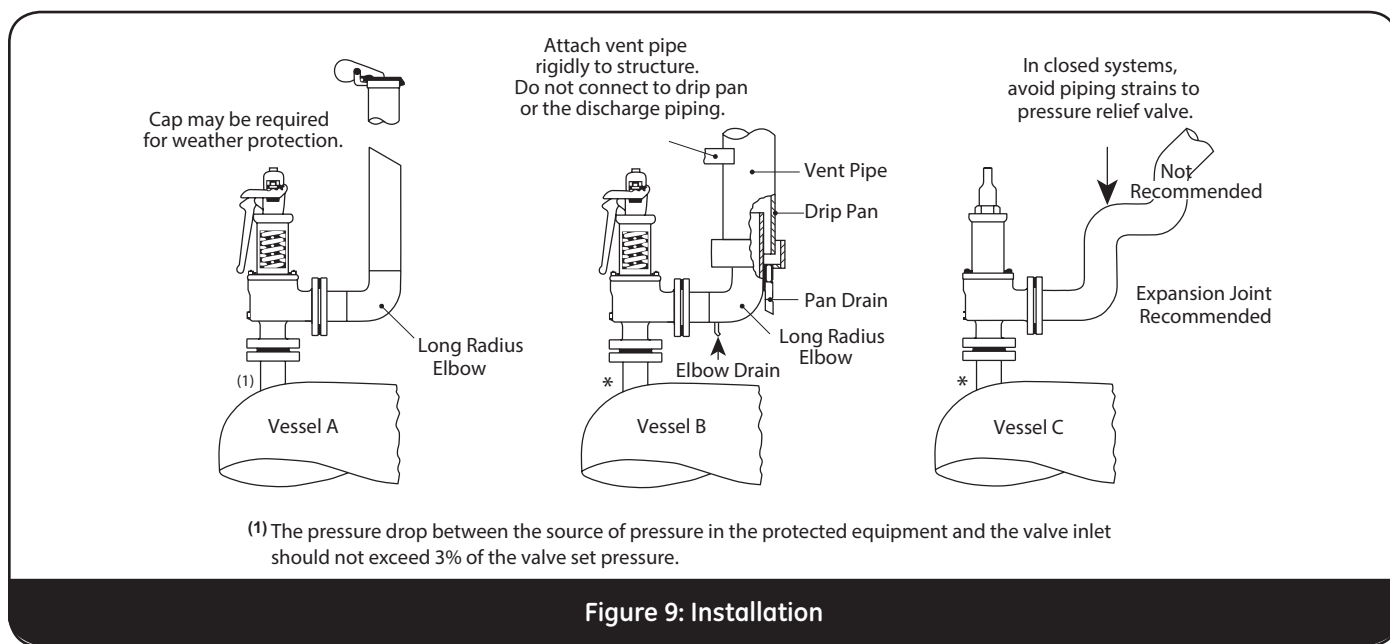

Figure 9: Installation

XIII. Disassembly of 1900/P Series Safety Relief Valves

Notes:

- A. It's a good policy to keep parts together by valve serial number. Serial number and valve type number are stamped into the top edge of the outlet flange and on the valve nameplate.
- B. For parts identification refer to Figures 1-8

The Consolidated 1900/P series safety relief valve can be disassembled by following the procedure outlined below:

1. Remove cap (including lifting gear) and cap gasket.
2. Remove adjusting ring pin and gasket. If the existing blowdown is to be restored upon reassembly, the position of the adjusting ring with respect to the disc holder must be determined. Turn the adjusting ring counterclockwise, i.e., move notches on the adjusting ring from left to right. Record the number of notches passing the ring pin hole required for the ring to contact the disc holder. This information will be used in setting the ring upon reassembly of the valve.
3. Use dial caliper or depth micrometer to measure and record dimension "A" of Figure 10 from the top of the spindle to the top of the adjusting screw. This will be used later for adjustment of the valve to near its original set pressure. Loosen the adjusting screw lock nut. Turn adjusting screw counter-clockwise to remove the spring load. When turning the adjusting screw use Vise-Grip® pliers to hold the spindle.

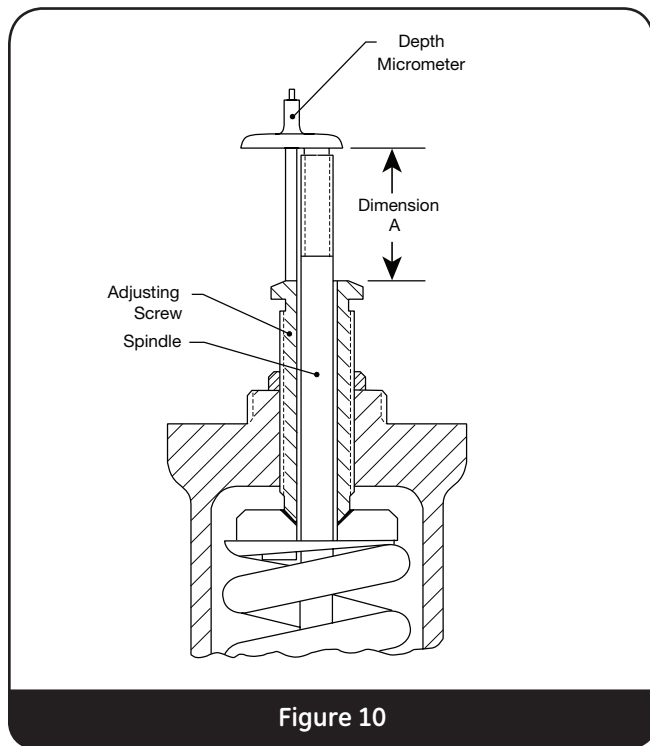

Figure 10

4. Remove the stud nuts and lift off the bonnet or yoke. Remove bonnet gasket.
5. Remove the spring and spring washers. The spring and spring washers should be kept together as a unit at all times.
6. All the upper internal parts can be removed as a unit by lifting out the spindle⁽¹⁾. These parts should be removed by lifting straight up. On bellows valves care should be taken not to bend or distort the bellows or its flange. Care should be taken to ensure that disc and spindle assembly are fully engaged before removal.
7. Remove the spindle from the disc holder. In valves as shown in Figures 1 to 7, it is necessary to rotate the spindle counter-clockwise only, while pulling up. This engages the drop-out thread.
8. Remove guide from the disc holder.
9. On D and E valves, remove the limit washer and tag with the valve serial number. If bellows D or E, tilt the disc holder bellows assembly and slide out the limit washer. The bellows is attached to the disc holder by right-hand threads. Apply a pin spanner wrench to the bellows ring and loosen bellows by turning counter-clockwise (Figure 11). The bellows convolutions are very thin metal and care should be taken to protect them from damage at all times. Remove bellows gasket.
10. Remove disc holder retainer ring using inside snap ring pliers (see Figure 29).
11. Separate disc holder, disc and holder ring.
12. Remove the adjusting ring from the nozzle by turning counter-clockwise and tag with valve serial number.
13. The nozzle should not be removed from the base unless necessary due to damage.

⁽¹⁾ In instances where valves are fouled with foreign materials and/or heavy products, disassembly may be eased if these parts are given a prior soaking in a suitable solvent.

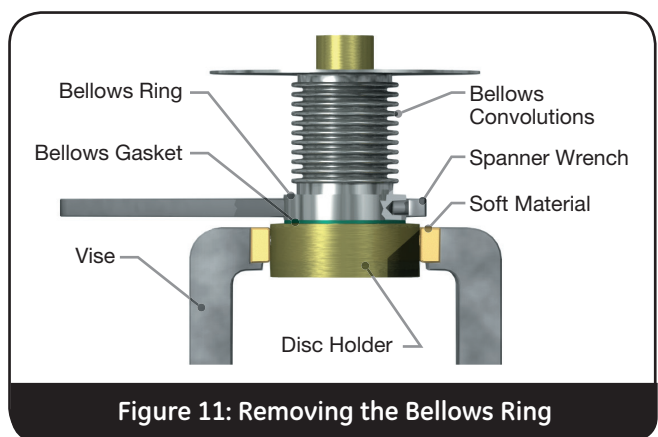

Figure 11: Removing the Bellows Ring

XIV. Maintenance Instructions

A. Machining of Nozzle Seat

All damaged parts, as determined by inspection, must be replaced with the exception of the valve nozzle, which may be machined as follows:

The nozzle seat should be machined with the nozzle assembled in the base whenever possible. If it should be necessary to remove the nozzle from the base, use the methods shown in Figure 12 or 13.

Use a hex wrench or pipe wrench as appropriate on nozzle flange to remove nozzle from base, or use a three-jaw chuck welded vertically to a stand bolted to the floor (see Figure 12).

Lathe set-up for machining of nozzle: grip the inlet flange of the valve in a four-jaw independent chuck (see Figure 14).

True up the work so that the top of the nozzle at "C" and the base surface at "B" run true within .001" (0.03 mm) on indicator.

If the nozzle has been removed, grip the nozzle in a fourjaw independent chuck using a piece of soft material such as copper or fiber between the jaws and the nozzle as shown at "A" (Figure 15).

True up the nozzle so that the surfaces marked "B", "C" and "D" run true within .001" (0.03 mm). on indicator.

Thermodisc: because of the critical shape of the disc, because of the critical shape of the disc, GE does not recommend machining of the disc. However, careful lapping may be done so long as dimensions in Figure 16 and Table 1 are maintained.

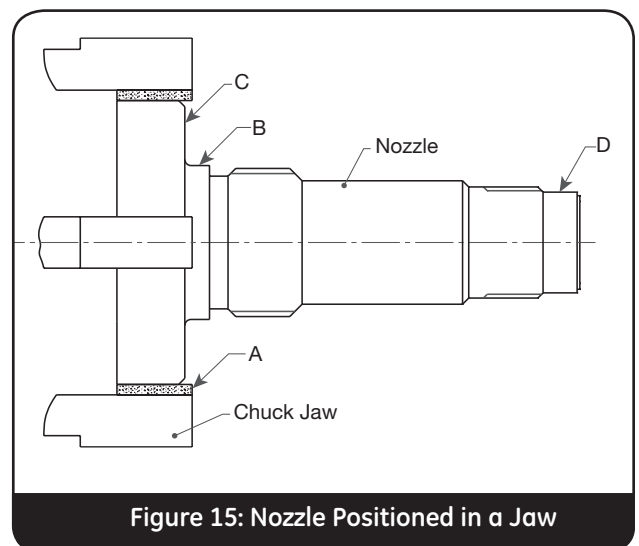
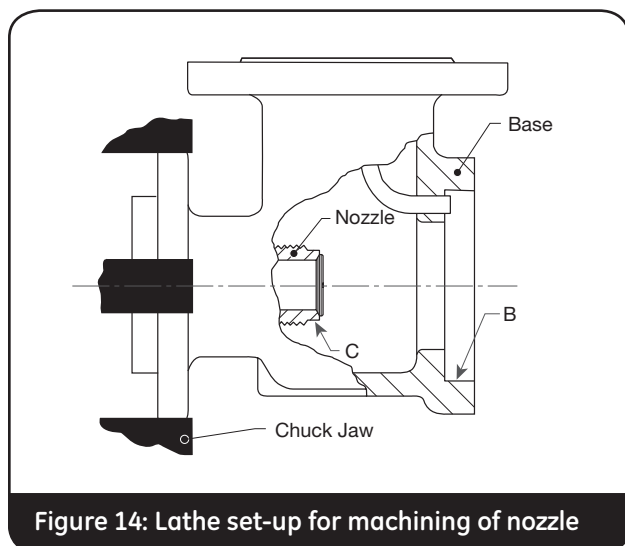
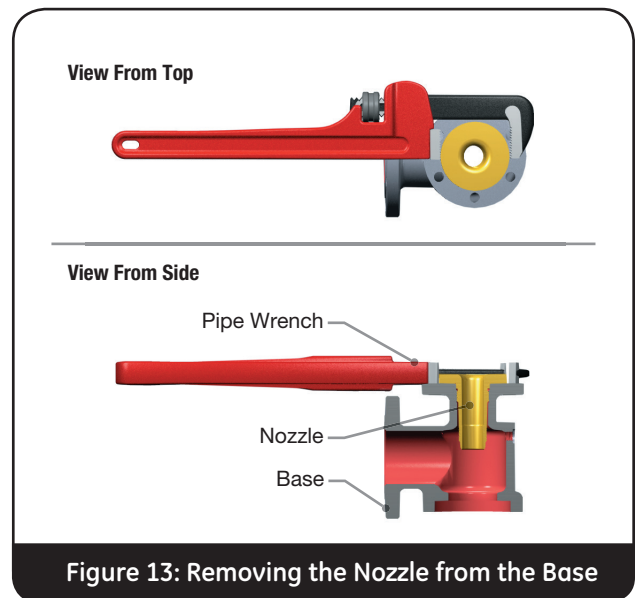
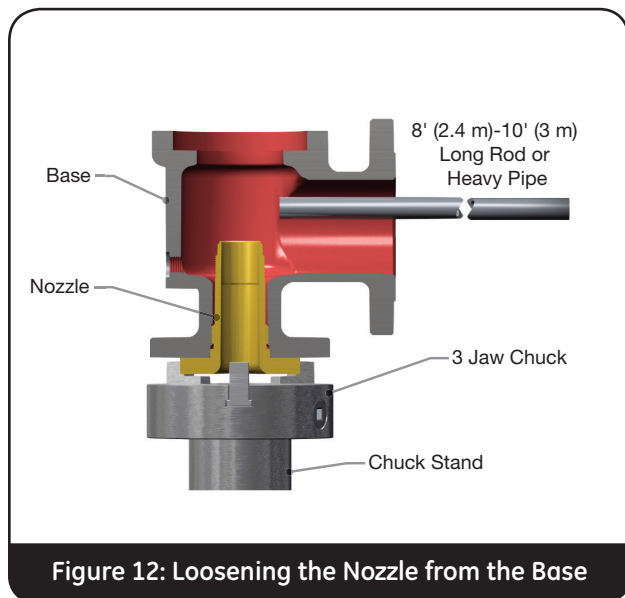

XIV. Maintenance Instructions (Contd.)

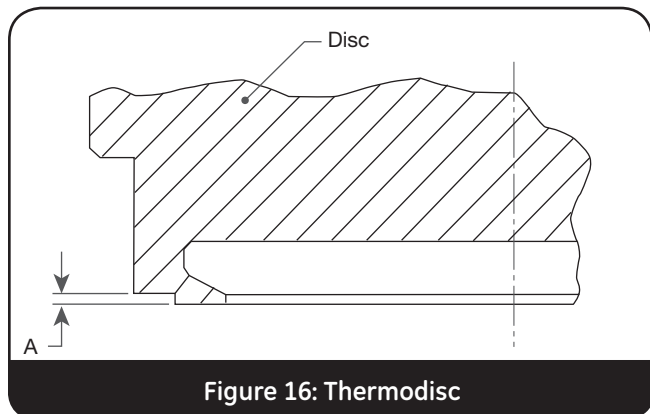

Figure 16: Thermodisc

Table 1: Minimum A Dimensions (Thermodisc)

Orifice	A min.	
	in.	mm
D thru M	.003	0.08
N thru T	.005	0.13

B. Lapping

Lapping is required to obtain the surface finish necessary for proper seating. Prior to lapping, Lap Ring must be reconditioned to ensure proper results.

C. Reconditioning of Ring Laps

Lap Rings are reconditioned by lapping them on a flat lapping plate. The lapping should be done with figure-eight motions as indicated in Figure 17. To obtain the best results, the Lap Rings must be reconditioned before each use.

Always run the outer edge of the lap beyond the edge of the plate to even wear.

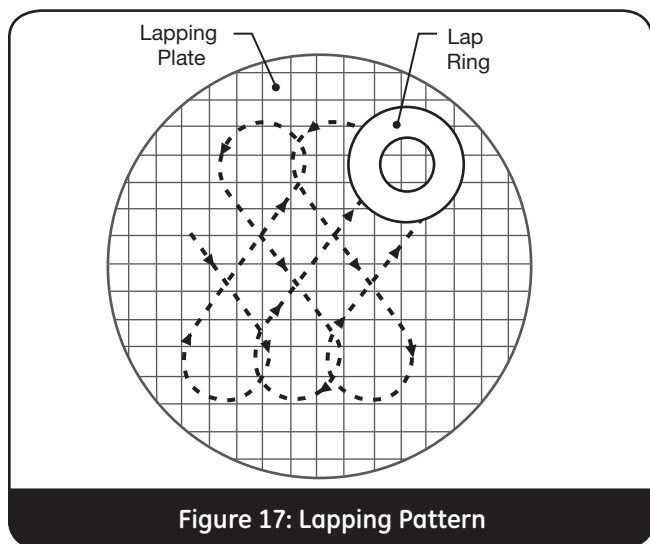

Figure 17: Lapping Pattern

Lapping Plate⁽¹⁾: The lapping plate is used for reconditioning Lap Rings. One 11" (279.40 mm) diameter cast iron plate is required for the entire range of valve sizes.

Lap Rings⁽¹⁾: Laps are flat cast iron rings.

Lapping Compound⁽¹⁾: Lapping compound is used as the cutting medium in lapping valve seats.

⁽¹⁾See *Maintenance Tools and Supplies (Section XIX)*.

D. General Lapping Comments

Seat lapping is an art and comes with practice and experience. To obtain the best results, the Lap Rings must be reconditioned before each use.

At first the parts will slide easily; however, as the seat becomes smooth and flat, the lap will drag noticeably. Clean the seat periodically for examination. When the seat is fully lapped, it will have a uniform dull light grey appearance. At this point, clean and apply 1000 grit and lap to a mirror finish. When lapping has been completed, any lines appearing as cross scratches can be removed by rotating the lap which has been wiped clean of compound - on the seat faces - about its own axis. With practice a quarter turn on #4/0 emery polishing paper accomplishes the same result. Clean with alcohol or other suitable cleaner.

A Surface Finish Comparator is used to determine surface finish number (microinch). For full details on surface finish numbers refer to ANSI B46.1 and/or Machinery's Handbook. In many cases a 1000 grit lap may be adequate. Both nozzle and disc seat surfaces must be 8 RMS finish or better.

Table 2: Typical Seat Lapping Recommendations

Seat Finish RMS	Repair Oper.	Grit
over 250	machine	-
over 125 - 250	grinding	320
over 16 - 125	grinding	500
16 and under	lapping	1000

E. Nozzle Lapping

When using the Lap Ring uniformly, coat the lap with a small amount of lapping compound. Keep the lap squarely on the nozzle seat and avoid any tendency to rock the lap, which will result in rounding of the seat. Keep a firm grip on the lap to prevent the possibility of dropping it and damaging the seat. Use an oscillating motion while applying very light force and if possible occasionally rotate the nozzle. (Do not turn the lap in just one direction.)

XIV. Maintenance Instructions (Contd.)

F. Thermodisc* Disc Lapping

Uniformly coat the disc with a small amount of lapping compound and place it on the Lap Ring. The operation is basically

the same as the nozzle except that the disc must be moved on the Lap Ring.

XV. Inspection and Part Replacement

Now all parts should be cleaned. First remove grease and sealants, then remove rust and scale. Inspect the internal parts to ensure they are not damaged by galling. Look especially at the rubbing surfaces of the guide and disc holder.

Inspect the spindle to ensure concentricity. Over-gagging is one of the common causes of bent spindles.

Inspect the spring and washer assembly for excess clearance [greater than .031" (0.79 mm)] and inspect the bearing surfaces for galling.

1. Between the upper spring washer and the adjusting screw
2. The lower spring washer and the spindle shoulder
3. Spring - look for corrosion pits. Replace the spring if severe corrosion or pitting is present. If the spring has been in service a long time, measure the free length of the spring. Contact GE and give this dimension, the spring number, and the valve set pressure to obtain their recommendations.

On all disc holders, inspect the bearing surface between the spindle pocket of the disc holder.

Inspect all bearing parts for concentricity, apply a very thin layer of Clover 3A grinding compound to the actual bearing surfaces, and grind together to determine if smooth, uninterrupted contact is made. If grinding does not restore the original condition or very close to it, then the parts should be replaced. Spherical surfaces should have a 63 RMS or better surface finish and their radius must be continuous. Each corresponding bearing surface should be conical and smooth with a 63 RMS or better surface finish. All traces of lapping compound must be carefully and totally removed prior to reassembly.

A surface finish comparator is required to obtain these readings. See Maintenance Tools and Supplies on Section XX.

The bellows (if present) should be visually inspected and perhaps reassembled to the disc holder with a good gasket, filled with water, and allowed to set for an hour or two to show any leakage. At conclusion, if a successful test, then dump the water and remove the gasket and allow the bellows to dry out. (Make sure bellows is dry when valve is reassembled).

If conventional valve with eductor tube, push a wire through the tube to check for plugging.

Nozzle - The nozzle seating surface must be inspected for nicks, cuts or grooves. Minor steam cuts can be lapped out. See

dimensions in (Figure 19) and Tables 3 and 4.

Thermodisc - If surface defects cannot be lapped out, the disc must be replaced. If after lapping, "A" in (Figure 16 in Section XIII) is less than "A min." (Table 1), replace the disc.

Adjusting Ring - The adjusting ring must have undamaged threads. Both surfaces "A" and "B" must be undamaged (see Figure 20).

Adjusting Ring Pin - Pin must be inspected to ensure that it is long enough to keep the Adjusting Ring from turning yet without touching the bottom of the notch (See Figure 20).

Gasket Surfaces - All gasket surfaces should be inspected for cleanliness and be without radial scratches. Be sure all pieces of the old gasket have been completely removed.

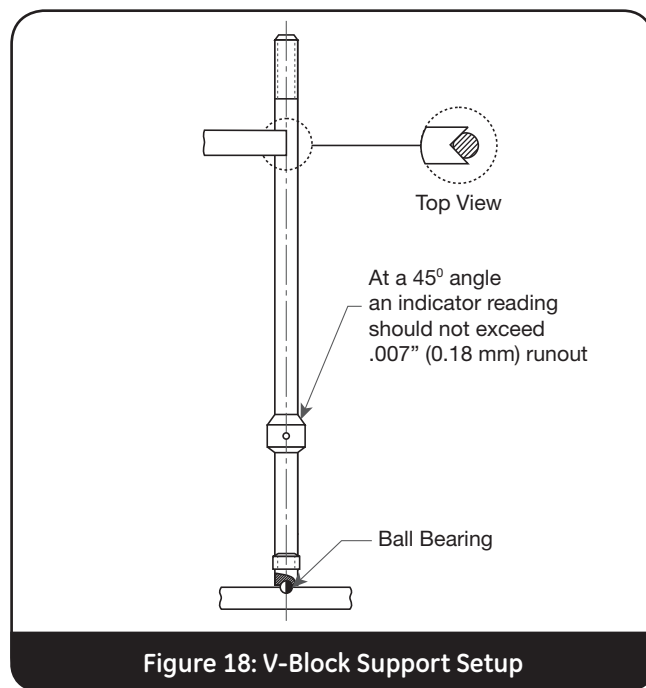

XV. Inspection and Part Replacement (Contd.)

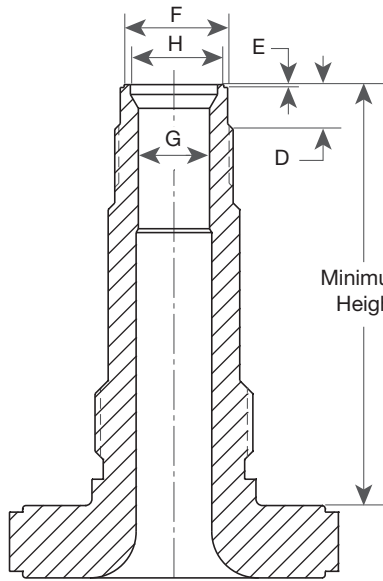

Figure 19a: Previous Design
Top Guided Nozzle

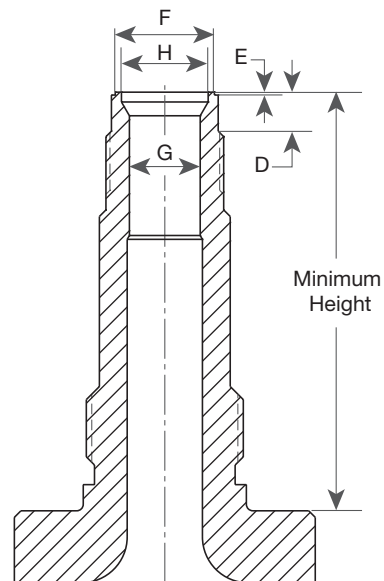

Figure 19b: Current Design
Bottom Guided Nozzle

Figure 19: Nozzle Critical Dimensions

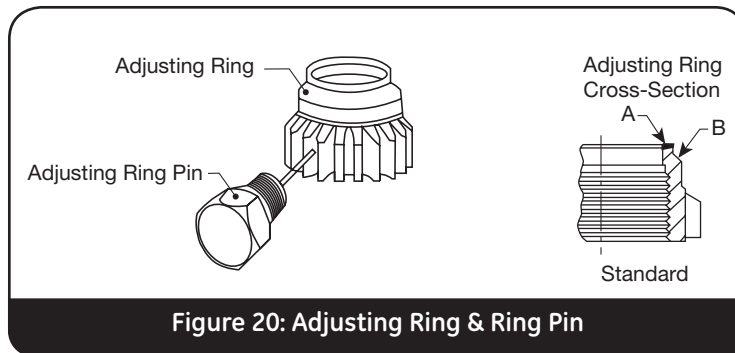

Figure 20: Adjusting Ring & Ring Pin

Table 3: Allowable Machining Dimensions for Nozzle Seat

Orifice	D min.		E $+0.005/-0.000$ " ($+0.13/-0.00$ mm)		F min.		G max.		H max.	
	in.	mm	in.	mm	in.	mm	in.	mm	in.	mm
D	.312	7.92	.025	0.64	.945	24.00	.679	17.25	.830	21.08
E	.312	7.92	.025	0.64	.945	24.00	.679	17.25	.830	21.08
F	.312	7.92	.025	0.64	.945	24.00	.679	17.25	.830	21.08
G	.312	7.92	.025	0.64	1.085	27.56	.868	22.05	.955	24.26
H	.250	6.35	.025	0.64	1.255	31.88	1.083	27.51	1.125	28.58
J	.375	9.53	.025	0.64	1.565	39.75	1.385	35.18	1.430	36.32
K	.437	11.10	.025	0.64	1.885	47.88	1.655	42.04	1.710	43.43
L	.437	11.10	.025	0.64	2.310	58.67	2.060	52.32	2.135	54.23
M	.437	11.10	.025	0.64	2.605	66.17	2.314	58.78	2.400	60.96
N	.500	12.70	.025	0.64	2.835	72.01	2.540	64.52	2.630	66.80
P	.625	15.88	.025	0.64	3.420	86.87	3.078	78.18	3.185	80.90
Q	.875	22.23	.025	0.64	4.425	112.40	4.050	102.87	4.180	106.17
R	1.000	25.40	.025	0.64	5.245	133.22	4.872	123.75	4.960	125.98
T	.750	19.05	.025	0.64	6.493	164.92	6.208	157.68	6.208	157.68

XV. Inspection and Part Replacement (Contd.)

Table 4: Nozzle Minimum Height Dimension														
Orifice	Valve Type													
	1905		1906		1910		1912		1914		1916		1918	
	in.	mm	in.	mm	in.	mm	in.	mm	in.	mm	in.	mm	in.	mm
D	3.359	85.32	3.359	85.32	3.359	85.32	3.469	88.11	3.469	88.11	3.469	88.11	4.547	115.49
E	3.359	85.32	3.359	85.32	3.359	85.32	3.469	88.11	3.469	88.11	3.469	88.11	4.547	115.49
F	3.922	99.62	3.922	99.62	3.922	99.62	3.922	99.62	3.922	99.62	3.922	99.62	4.547	115.49
G	4.109	104.37	4.109	104.37	4.109	104.37	4.109	104.37	4.109	104.37	5.359	136.12	5.359	136.12
H	3.922	99.62	3.922	99.62	3.922	99.62	4.859	123.42	4.859	123.42	4.859	123.42	-	-
J	4.422	112.32	4.422	112.32	5.922	150.42	5.922	150.42	5.922	150.42	5.922	150.42	-	-
K	4.734	120.24	4.734	120.24	4.734	120.24	5.859	148.82	6.422	163.12	6.422	163.12	-	-
L	4.984	126.59	4.984	126.59	5.922	150.42	5.922	150.42	6.609	167.87	6.609	167.87	-	-
M	5.359	136.12	5.359	136.12	5.359	136.12	5.359	136.12	6.109	155.17	-	-	-	-
N	5.984	151.99	5.984	151.99	5.984	151.99	5.984	151.99	5.984	151.99	-	-	-	-
P	5.734	145.64	5.734	145.64	7.484	190.09	7.484	190.09	7.484	190.09	-	-	-	-
Q	7.359	186.92	7.359	186.92	7.359	186.92	7.359	186.92	-	-	-	-	-	-
R	7.797	198.04	7.797	198.04	7.797	198.04	7.797	198.04	-	-	-	-	-	-
T	7.859	199.62	7.859	199.62	7.859	199.62	7.859	199.62	-	-	-	-	-	-

Table 4: Nozzle Minimum Height Dimension (Contd.)													
Orifice	Valve Type												
	1920		1922		1923		1924		1926		1928		
	in.	mm	in.	mm	in.	mm	in.	mm	in.	mm	in.	mm	
D	3.359	85.32	3.359	85.32	-	-	3.469	88.11	3.469	88.11	4.547	115.49	
E	3.359	85.32	3.359	85.32	-	-	3.469	88.11	3.469	88.11	4.547	115.49	
F	3.922	99.62	3.922	99.62	-	-	3.922	99.62	3.922	99.62	4.547	115.49	
G	4.109	104.37	4.109	104.37	-	-	4.109	104.37	5.359	136.12	5.359	136.12	
H	3.922	99.62	3.922	99.62	-	-	4.859	123.42	4.859	123.42	-	-	
J	5.922	150.42	5.922	150.42	-	-	4.797	121.84	5.922	150.42	-	-	
K	4.734	120.24	4.734	120.24	-	-	5.859	148.82	6.422	163.12	-	-	
L	5.922	150.42	5.922	150.42	-	-	6.609	167.87	6.609	167.87	-	-	
M	5.359	136.12	5.359	136.12	-	-	5.359	136.12	6.109	155.17	-	-	
N	5.984	151.99	5.984	151.99	-	-	5.984	151.99	-	-	-	-	
P	7.484	190.09	-	-	7.484	190.09	7.484	190.09	-	-	-	-	
Q	7.359	186.92	7.359	186.92	-	-	7.359	186.92	-	-	-	-	
R	7.797	198.04	7.797	198.04	-	-	-	-	-	-	-	-	
T	7.859	199.62	7.859	199.62	-	-	-	-	-	-	-	-	

XVI. Reassembly of 1900/P Series Safety Relief Valves

Notes:

- A. Check all gaskets used during reassembly. Undamaged solid metal gaskets (not pitted or creased) can be reused. All soft gaskets must be replaced. Before placing the (flat) gaskets, apply a light uniform coating of lubricant to the surface to be gasketed; then coat the top of the gasket with lubricant.
- B. Before reassembling the valve, all parts should be cleaned. Special attention should be given to guiding surfaces, bearing surfaces, flange faces, retainer recesses and grooves.
- C. If grinding in of bearing parts is required, use Clover® Grade 3A (see Section XV, "Inspection"), and be sure to remove all grinding compounds and thoroughly clean both surfaces and rinse with alcohol or other suitable cleaner.
- D. On D and E valves, be sure to measure the required lift before final assembly. See Section XVII for instructions.
- E. The final step before final assembly is lubrication. Apply lubricants sparingly, but be sure that each bearing surface is lightly by uniformly covered. For lubricant see "Maintenance Tools and Supplies" on Section XX.

A. Reassembly of the valve

1. If the nozzle was removed, apply lubricant to the nozzle threads before reinstalling the nozzle into the base, then tighten.
2. Reinstall the adjusting ring to the nozzle. Make sure the ring is low enough on the nozzle to allow sufficient clearance between the disc holder and the adjusting ring so that the disc will seat on the nozzle and not on the ring (see Figure 21 & Table 5).
3. a) On D and E valves, if the nozzle does not require any machining, the same limit washer (tagged during disassembly) may be used again. However, lift should

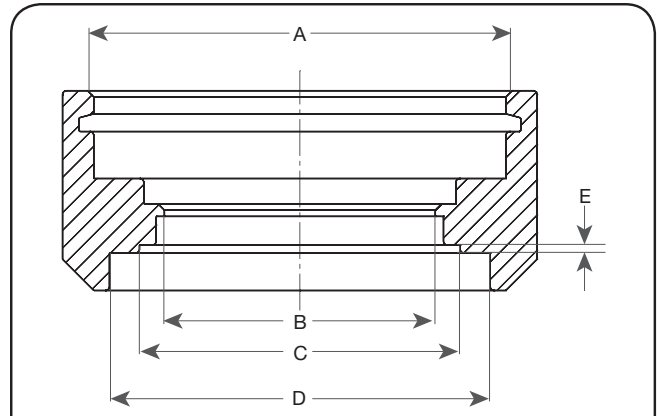

Figure 21: Ring Holder Critical Dimensions

be checked and verified correct as described on Section XVI.B.

- b) If D or E valve nozzle was remachined, measure the required lift before final assembly.(Section XVI.B.)
4. Assemble disc, holder ring and disc holder. Use care to avoid seat damage during assembly. Insert retainer ring bevelled side upwards in groove using proper inside snap ring pliers (Figure 29).
5. On bellows valves (see Figure 11), place a new bellows gasket on the disc holder. Thread the bellows down to the gasket finger tight on the disc holder. Using a pin spanner wrench or special cable type wrench, turn the bellows ring down until a pressure tight seal is obtained.
6. On D and E restricted lift valves, install the limit washer.
7. Place the guide over the disc holder. DO NOT DROP. If bellows is present, the weight of the guide will slightly compress the bellows.
8. Apply lubricant sparingly to the inside conical end of the spindle.

Table 5: Ring Holder Critical Dimensions

Orifice	A max.		B max.		C max.		D max.		E max.	
	in.	mm	in.	mm	in.	mm	in.	mm	in.	mm
D, E, F	1.814	46.08	1.057	26.85	1.225	31.12	1.484	37.69	.065	1.65
G	1.814	46.08	1.188	30.18	1.327	33.71	1.703	43.26	.070	1.78
H	2.064	52.43	1.358	34.49	1.610	40.89	1.922	48.82	.075	1.91
J	2.502	63.55	1.675	42.55	2.055	52.20	2.516	63.91	.095	2.41
K	2.872	72.95	2.010	51.05	2.455	62.36	3.016	76.61	.095	2.41
L	3.253	82.63	2.435	61.85	3.055	77.60	3.734	94.84	.095	2.41
M	3.753	95.33	2.725	69.22	3.438	87.33	4.266	108.36	.105	2.67
N	3.753	95.33	2.961	75.21	3.760	95.50	4.641	117.88	.105	2.67
P	4.628	117.55	3.552	90.22	4.560	115.82	5.641	143.28	.105	2.67
Q	5.753	146.13	4.562	115.87	5.995	152.27	7.391	187.73	.105	2.67
R	6.628	168.35	5.382	136.70	7.115	180.72	8.766	222.66	.105	2.67
T	8.003	203.28	6.566	166.78	9.220	234.19	10.766	273.46	.105	2.67

XVI. Reassembly (Contd.)

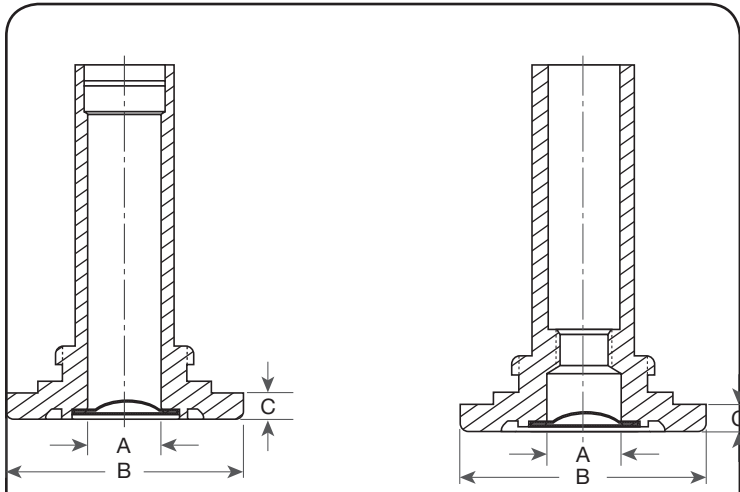

Figure 22a:
D-G Orifice

Figure 22b:
H-T Orifice

Figure 22: Disc Holder

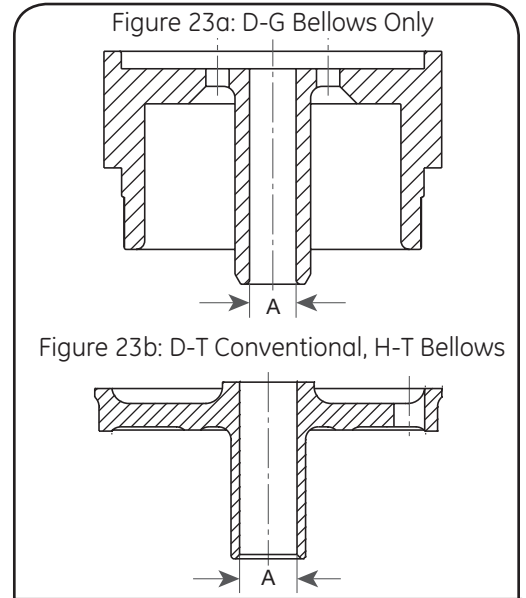

Figure 23b: D-T Conventional, H-T Bellows

Figure 23: Guide

Table 6: Disc Holder Critical Dimensions

Orifice	A min.				B min.		C min.	
	Conventional		Bellows		in.	mm	in.	mm
	in.	mm	in.	mm				
D, E, F	.994	25.25	.548	13.92	1.808	45.92	.215	5.46
G	.993	25.22	.548	13.92	1.808	45.92	.215	5.46
H	.679	17.25	.679	17.25	2.058	52.27	.247	6.27
J	.992	25.20	.992	25.20	2.496	63.40	.279	7.09
K	1.241	31.52	1.241	31.52	2.869	72.87	.309	7.85
L	1.366	34.70	1.366	34.70	3.244	82.40	.340	8.64
M	1.742	44.25	1.742	44.25	3.744	95.10	.403	10.24
N	1.869	47.47	1.869	47.47	3.743	95.07	.403	10.24
P	2.303	58.50	2.303	58.50	4.618	117.30	.465	11.81
Q	3.485	88.52	3.485	88.52	5.742	145.85	.340	8.64
R	3.985	101.22	3.985	101.22	6.620	168.15	.372	9.45
T	5.187	131.75	5.187	131.75	7.992	203.00	.434	11.02

Table 7: Maximum Guide Inside Diameter

Orifice	Conventional		Bellows	
	in.	mm	in.	mm
D, E, F	1.000	25.40	.556	14.12
G	1.000	25.40	.556	14.12
H	.688	17.48	.688	17.48
J	1.001	25.43	1.001	25.43
K	1.251	31.78	1.251	31.78
L	1.376	34.95	1.376	34.95
M	1.751	44.48	1.751	44.48
N	1.876	47.65	1.876	47.65
P	2.314	58.78	2.314	58.78
Q	3.501	88.93	3.501	88.93
R	4.001	101.63	4.001	101.63
T	5.205	132.21	5.205	132.21

Table 8: Maximum Clearance Guide & Disc Holder

Orifice	Conventional		Bellows	
	in.	mm	in.	mm
D, E, F	.006	0.15	.008	0.20
G	.007	0.18	.008	0.20
H	.009	0.23	.009	0.23
J	.009	0.23	.009	0.23
K	.010	0.25	.010	0.25
L	.010	0.25	.010	0.25
M	.009	0.23	.009	0.23
N	.007	0.18	.007	0.18
P	.011	0.28	.011	0.28
Q	.016	0.41	.016	0.41
R	.016	0.41	.016	0.41
T	.018	0.46	.018	0.46

XVI. Reassembly (Contd.)

9. a) For all conventional and H thru T bellows valves, place spindle in disc holder assembly, thread in all the way, and be sure spindle feels "free".
 - b) For bellows D through G valves, a ring type retainer is used. Place the spindle retainer ring on the spindle below the enlargement prior to installing the spindle into the disc holder assembly, and snap the ring into the internal groove at the top of the disc holder (Figure 1) using an awl.
10. Place proper guide gasket in the base. If conventional valve, use metal gasket and if bellows valve, use soft (non-asbestos) gasket.
11. Install the spindle/disc holder assembly and guide by gently lowering into the valve base. Take care to align the hole(s) in the guide over the extended end of the eductor tube(s), refer Figure 24.

Note: Bellows valves do not have an eductor tube.

12. Apply a small quantity of lubricant to the spring washer bearing surface of the spindle. Place the spring assembly on the spindle.
13. Place bonnet gasket in the base prior to installing the bonnet. Uniformly tighten the bonnet stud nuts using the pattern shown in Figure 25.
14. With the adjusting screw lock nut assembled near the top of the adjusting screw, apply a small quantity of lubricant to the spherical end of the adjusting screw and also lubricate the

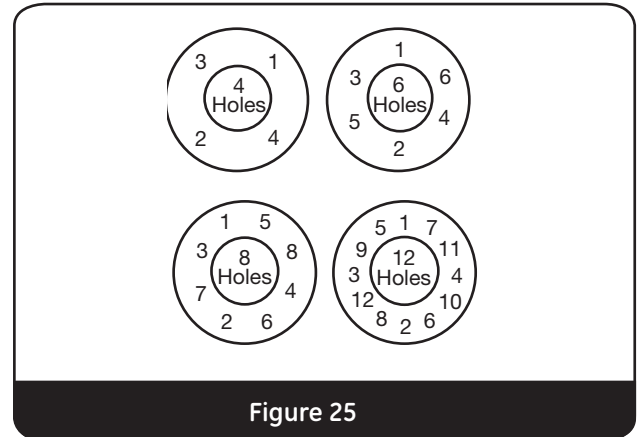
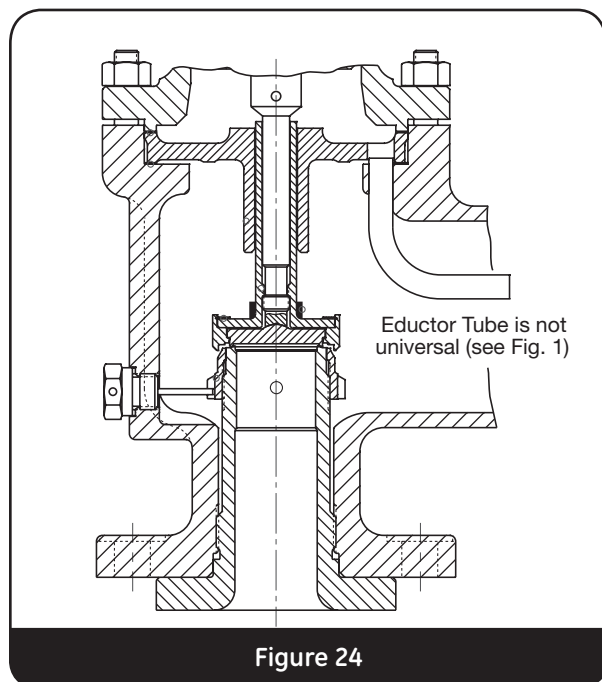

threads. Thread the adjusting screw into the bonnet until it contacts the spring washer.

15. When compressing the spring, hold the spindle with Vise-Grip® pliers to prevent the spindle from turning in the disc holder. Turn the adjusting screw clockwise until the original distance between the end of the spindle and the top the adjusting screw is obtained. This method of compressing the spring will approximately re-establish the original set pressure. This is approximate - the valve must be reset for the required pressure.
16. Restore the adjusting ring to its original position with reference to the disc holder as recorded, and replace the adjusting ring pin using a new gasket. If the original position of the ring is not known, position the ring in accordance with Table 11.

Be sure the ring pin enters the notch in the ring but does not bind the ring. The ring should feel free after the pin has been installed. If necessary, cut the pin to the needed length or replace the pin (see Figure 20).
17. The valve is now ready for setting and testing.

B. Checking Lift on D and E Valves

It is important to check the length of the lift restricting washer on all D and E "restricted lift" valves after servicing or replacement of parts. This is necessary to ensure the reliability of the nameplate capacity.

Notes:

- A. The limit washer must be chamfered to clear disc holder fillet radius.
- B. For bellows valves, the limit washer must also be chamfered on the lower O.D. as shown in Figure 26.
- C. Do not interchange internal parts or use a different base after parts have been custom fitted.

XVI. Reassembly (Contd.)

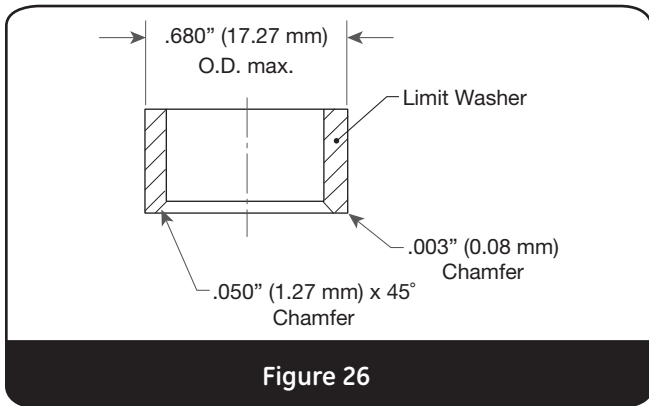

Figure 26

C. Limit Washer Length

Use the following procedure and Figure 27 to determine the correct limit washer length:

1. Use care to avoid seat damage. Assemble disc holder ring and disc holder by inserting the holder retainer ring, beveled side upward, in the groove using the proper inside snap ring pliers (see Figure 29). Screw the bellows, if present, onto the disc holder using a new gasket.
2. Tilt the above assembly and slide the limit washer along the disc holder until it rests on the shoulder of the disc holder. Be sure the chamfered edge of the limit washer is down against the shoulder.
3. Install the guide before placing the spindle assembly into the disc holder assembly.
4. Install the guide gasket. Insert the assembly from Step 3 into the base.
5. Install bonnet gasket and bonnet, leaving out the spring assembly at this time.

6. Tighten nuts to compress gasket. Do not use impact wrench on bellows valves.
7. Place dial lift indicator on bonnet and over spindle, then zero indicator.
8. By inserting a wood dowel through the nozzle, push the disc up as far as it will go and measure the lift. Do not lift the spindle as this will result in a false reading.
9. Subtract the required lift of the valve from the measured lift to find the required limit washer length.

Note: The required lift is

$$\begin{aligned}
 &\text{- for a D orifice } .086" (2.18 \text{ mm}) \begin{matrix} +.005" (0.13 \text{ mm}) \\ -.000" (0.00 \text{ mm}) \end{matrix} \\
 &\text{- for an E orifice } .139" (3.53 \text{ mm}) \begin{matrix} +.005" (0.13 \text{ mm}) \\ -.000" (0.00 \text{ mm}) \end{matrix}
 \end{aligned}$$

10. Machine the limit washer to the required length. Chamfer the inside lower edge, deburr and polish as required.
11. Disassemble the valve, install the limit washer (with chamfer down), and reassemble valve as before. Measure the actual lift of the valve and compare it with the required lift of the valve as noted in Step 9.
12.
 - a) If the actual lift is less than required, machine the limit washer the additional amount to obtain the required lift. (Machine chamfer and deburr before installation into valve.)
 - b) If the actual lift is greater than the required amount, obtain new limit washer and begin again with Step 9. (Machine chamfer and deburr before installation into valve.)
13. Disassemble valve and continue with next step of Reassembly on Section XIV.A.

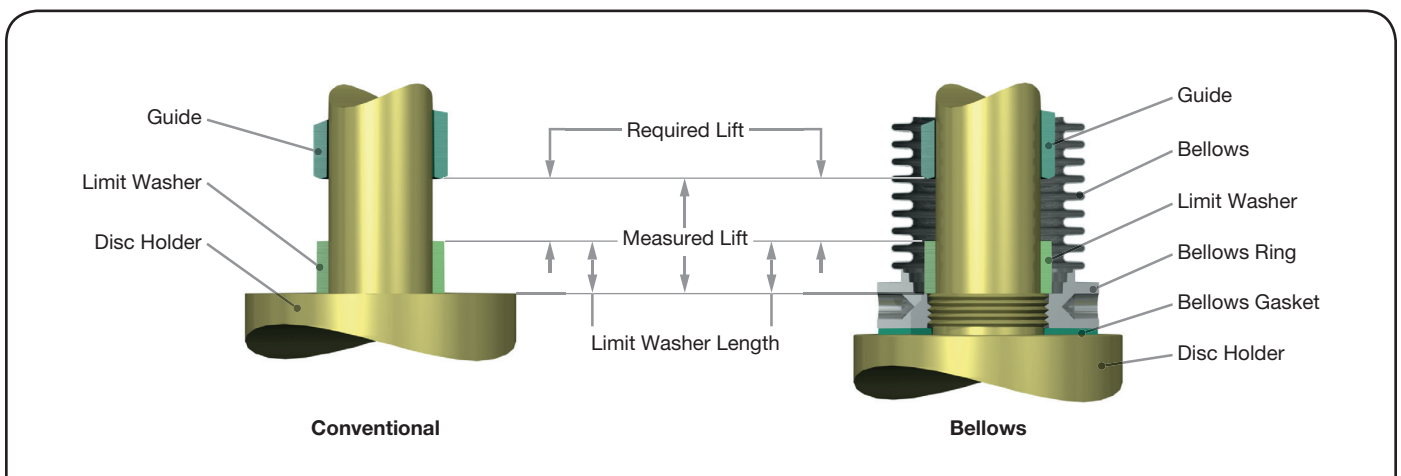

Figure 27: Determining Lift and Limit Washer Length

XVII. Setting and Testing

Read and follow Safety Alerts on Section II. For Valve Terminology see Section V.

Gauges used in valve setting must be kept calibrated in accordance with applicable codes and standards.

Test Medium

Steam Internals valves shall be tested on saturated steam as required by the ASME Code. The test medium must be clean. Before mounting the valve on the test stand, remove all dirt, etc. from the test receiver nozzle (valve inlet piping).

Set Pressure (Opening Pressure)

Set Pressure is dependent on spring tension which is controlled by an adjusting screw located on top of the valve. For accurate valve setting, pressure increases must be a slow but uniform rate, but rapid enough to cause the valve to open.

Table 9: ASME Code Section I		
Set Pressure Range		Tolerance
psig	barg	
15 to 70	1.03 to 4.83	± 2 psig (± 0.14 barg)
71 to 300	4.89 to 20.68	±3 percent of set
301 to 1000	20.75 to 68.95	± 10 psig (0.69 barg)
1000 & Greater	68.95 & Greater	± 1 percent of set

Table 10: ASME Code Section VIII		
Set Pressure		Tolerance
psig	barg	
0 to 70	0 to 4.83	± 2 psig (± 0.14 barg)
Over 70	Over 4.83	± 3 percent

A. Setting the Valve

Hold the spindle with Vise-Grip® pliers and set the valve to the required set pressure by turning the adjusting screw clockwise to increase the set pressure - counter-clockwise to decrease the set pressure - then lock the adjusting screw lock nut using two wrenches. Use one wrench to hold the adjusting screw from moving while using the other wrench to tighten the lock nut.

Open the valve only sufficient number of times to ensure that the valve opens three times in succession at the desired set pressure.

Simmer - If simmer causes erratic valve opening, refer to Table 12, "Troubleshooting Guide".

B. Back Pressure Compensation

When testing with steam, no temperature compensation is required.

Conventional Valves: required to open against constant back pressure. The back pressure must be subtracted from the required set pressure to determine the test stand set pressure.

Bellows Valve: all Steam Internals bellows are balanced by design; therefore, they require no back pressure correction.

C. Blowdown (Reclosing Pressure)

The Steam Internals pressure relief valves are blowdown adjustable by design, but do not attempt to adjust blowdown on the stand because the test stand capacity may not be large enough to permit doing so.

Be sure to lower the working pressure before making any ring adjustment. This allows the spring force to keep the valve closed otherwise the valve may pop during adjustment. If the cap has a sealing plug, then use the gag supplied finger-tight to prevent "popping" during ring adjustment.

The adjusting ring may be moved to improve action during testing as the valve must operate smoothly without hang-up, and it must reclose. In general, raising the ring increases blowdown, and lowering the ring reduces blowdown.

To adjust blowdown:

1. Remove ring pin and gasket
2. Insert a small shank screwdriver through the ring pin hole and engage a slot in the ring (see Figure 20).
3. To increase blowdown (lower reseating pressure), the adjusting ring must be raised by moving the notches counter-clockwise.
4. To decrease blowdown (raise reseating pressure), the adjusting ring must be lowered by moving the notches clockwise.

After testing, place the ring in its original position or if unknown, use Table 11 to relocate it. Be sure to remove the gag (if used) and replace the sealing plug and gasket after ring adjustment.

Section I valves, if possible, should have their blowdown adjusted on the installation. If the original setting is unknown, then use Table 11 as a guide. Further adjustment may be necessary.

XVII. Setting and Testing (Contd.)

For Section VIII valves, set the ring in the original position or if unknown, use Table 11.

D. Seat Leakage

Seat Leakage is the escape of fluid with no valve lift.

Steam

Follow Safety Alerts on Section II.

Test seat leakage at 90 percent of the set pressure or 5 psig (0.34 barg), whichever is greater. The ASME Codes require that valves must be tight at operating pressures. After the valve has been set at the required pressure and has reseated, yet before it reaches operating pressure, seat should be tested for leakage after the valve interior has dried. If there is no visual or audible leakage, then pass a polished metal rod (temp. of rod not to exceed 100°F or 38°C) slowly around the valve outlet and observe if moisture forms on the rod. If the rod remains dry, the valve is acceptable. If leakage is observed, the valve must be reworked.

E. Recommended Back Pressure Testing for Joint Leakage

After the valve has been set for the correct opening pressure, valves with closed bonnets and caps are recommended to be back pressure tested. Testing can be conducted by installing cap with gasket and applying air or nitrogen to the base drain connection or to the valve outlet. All other openings must be sealed.

Test pressure should be at least 10 percent of the valve set pressure or 30 psi (2.07 barg), whichever is greater. Air nitrogen pressure would be held for 3 minutes before applying leak detector solution to all connections (joints).

On bellows valves, also install a clean pipe plug in the bonnet vent connection until it's just short of finger tight. The purpose is to obtain the smallest possible leak.

Examine the following for leakage during back pressure testing:

1. Nozzle/base joint
2. Adjusting ring pin seal
3. Base/bonnet joint
4. Bonnet/cap joint
5. If conventional valve, examine the "tight" bonnet vent plug.
6. If bellows valve, examine the "loose" bonnet vent plug.

Leakage is best detected by application of a commercial liquid leak detector, i.e. Snoop®. Use of soap or household detergent as a leak detector is not recommended as it may bridge small leaks.

Repair of leaking valve joints may be attempted by tightening the leaking joint while the valve is still on the stand. If this does

not stop the leak, tear down and inspect the leaking joint(s), both metal surface and gasket.

If the valve internals have been disturbed, it is necessary to retest to this manual, otherwise repeat the back pressure tests as outlined above.

F. System Hydrostatic Testing

If the hydro pressure approaches set pressure, a test gag must be used to keep the valve closed. Apply gag hand-tight. DO NOT WRENCH TIGHTEN. Over gagging may bend the spindle and damage the disc thermo lip. After hydrostatic testing the gag must be removed and replaced by the sealing plug (gag replacement plug) furnished for this purpose. Test gags and sealing plugs are available from GE.

For hydro pressure exceeding 1.5 times the set pressure stamped on the name plate, GE recommends that the valve be removed and a blind flange be installed to avoid internal damage to the valve.

When a P3 series valve, supplied with an open bonnet, is used for outdoor service, GE recommends that a Weather Shield be used to protect against ice build-up and to help stabilize the spring temperature.

XVII. Setting and Testing (Contd.)

G. Adjusting Ring Settings

**Table 11: Adjusting Ring Settings for Steam Service¹
Metal-to-Metal Seats for Steam Internals**

Orifice	No. of Notches	Set ≤ 100 psig (6.89 barg) ¹	Set > 100 psig (6.89 barg) ¹
D	24	2 Notches	6 Notches
E	24	2 Notches	6 Notches
F	24	2 Notches	6 Notches
G	30	2 Notches	6 Notches
H	30	2 Notches	6 Notches
J	30	2 Notches	8 Notches
K	32	8 Notches	19 Notches
L	40	10 Notches	31 Notches
M	40	10 Notches	30 Notches
N	40	10 Notches	30 Notches
P	40	14 Notches	42 Notches
Q	48	17 Notches	47 Notches
R	48	42 Notches	64 Notches
T	24	30 Notches	38 Notches

Note 1: Position Below Disc Holder

XVIII. Troubleshooting Guide for Safety Relief Valves

Table 12: Troubleshooting Guide

Problem	Specific	Probable Cause	Corrective Action
Opening	Simmer	<ul style="list-style-type: none"> Operating pressure too close to set pressure Adjusting ring too low 	<ul style="list-style-type: none"> Increase differential Raise ring
	Chatter	<ul style="list-style-type: none"> Flow starved inlet pressure drop too large built up back pressure valve too large 	<ul style="list-style-type: none"> See Figure 9 Check discharge piping Check piping system
	Erratic Set	<ul style="list-style-type: none"> Mechanical bind Temperatures differential Fatigued spring 	<ul style="list-style-type: none"> Check valve piping Stabilize valve temperature Replace Spring
Closing	Long Blowdown	<ul style="list-style-type: none"> Adjusting ring too high Hang-up 	<ul style="list-style-type: none"> Lower ring See "Closing/Hang-up"
	Hang-up (does not fully close)	<ul style="list-style-type: none"> Adjusting Ring too high Pipe Loads Misalignment of Parts Mechanical binding Corrosion 	<ul style="list-style-type: none"> Lower ring See Figure 9 See Figure 9, be sure valve is vertical and properly reassembled Improper valve assembly Improper material selection
Seat Leakage	Simmer	<ul style="list-style-type: none"> See "Opening" 	<ul style="list-style-type: none"> See "Opening"
	Leakage	<ul style="list-style-type: none"> Vibration Piping loads Operating pressure too close to set pressure Solids trapped on seat Mechanical binding Improper assembly Valve oversized 	<ul style="list-style-type: none"> Check piping system See Figure 9 Increase differential Lift lifting lever if equipped or inspect for seat damage See "Closing/Hang-up" Remove valve and inspect parts Recheck piping system

Note: For Valve Terminology see Section V.

XIX. 1900/P Series PRV Options

A. Cap and Weather Shield Options

Steam Internals caps are supplied in accordance with customer order and/or the ASME Code. All caps for the same size valve are interchangeable and are available with or without gag.

Manual Popping: on steam application after the valve has been in use, it may be necessary when permitted:

- to lift the disc from the valve seat periodically during operations to ensure that the disc is not frozen, etc. as a result of corrosion/boiler water deposits. Operating pressure under the disc should be approximately 75 percent of the set pressure when lifting in accordance with the ASME Code;

otherwise, the lever assembly including spindle may be damaged.

- to dislodge foreign particles that sometimes become trapped on the seating surface as the valve recloses. Prompt lifting of the lever, using system fluid pressure to clean the seat, should correct an otherwise leaking valve and save maintenance costs at a later date.

Refer to Figure 28 for more information.

XIX. 1900/P Series PRV Options (Contd.)

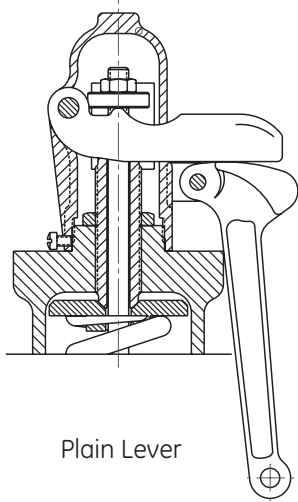

Plain Lever

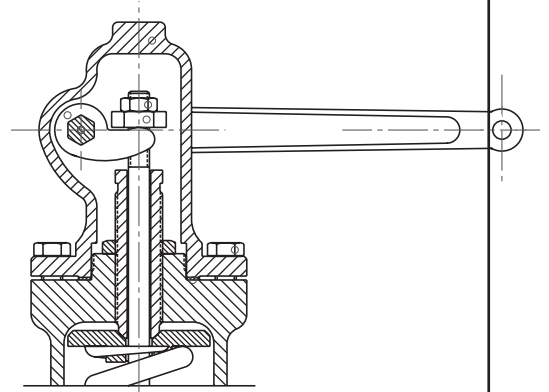

Packed Lever

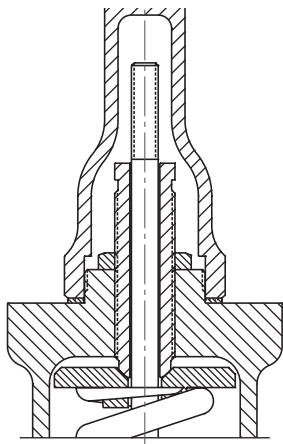

Screwed Cap

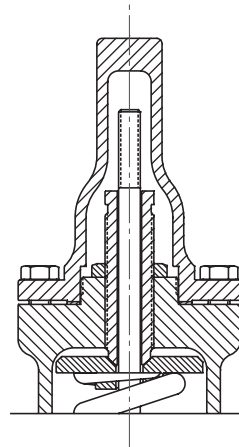

Bolted Cap

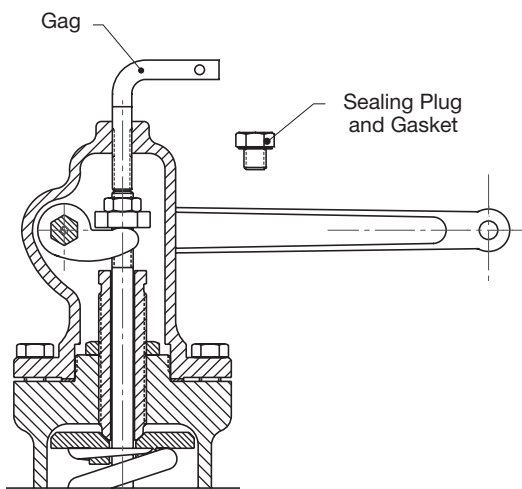

Packed Lever with Gag

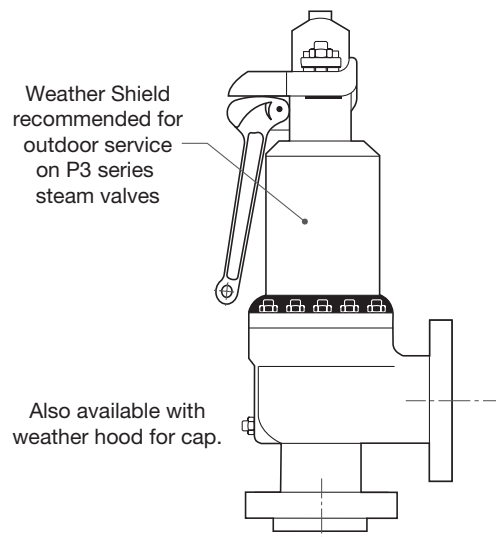

Weather Shield recommended for outdoor service on P3 series steam valves

Also available with weather hood for cap.

Figure 28: Cap and Weather Shield Options

XX. Maintenance Tools and Supplies

Lubricants: use on all metal-to-metal bearing surfaces, gasket surfaces, and all threaded parts for ease of maintenance. Nickel-Ease, a speciality lubricant, is available from Fel-Pro, Inc., Box C1103, Skokie, Illinois 60076.

Surface Finish Comparator: a pen type surface finish comparator is available from Miniature Precision Components, Inc., 100 Wisconsin St., Walworth, Wisconsin 53184.

The following special tools are required:

- A. Pin Spanner Wrench
- B. Inside Snap Ring Pliers
- C. Lap Rings
- D. Lap Plate
- E. Lapping Compounds

A. Pin Spanner Wrenches

For removal of Bellows from Disc Holder

Table 13: Pin Spanner Wrench Dimensions					
Valve Orifice	Pin Spanner Wrench				Part No.
	Radius		Pin		
	in.	mm	in.	mm	
D thru G	.750	19.05	.219	5.56	4451801
H	.875	22.23	.234	5.94	4451802
J	1.125	28.58	.266	6.76	4451803
K	1.250	31.75	.281	7.14	4451804
L	1.375	34.93	.297	7.54	4451805
M	1.625	41.28	.328	8.33	4451806
N and P	1.875	47.63	.359	9.12	4451807
Q	1.500	38.10	.438	11.13	4451808
R	3.000	76.20	.500	12.70	4451809
T	3.750	95.25	.500	12.70	4451810

B. Inside Snap Ring Pliers

For removal of Holder Ring Retainer

Table 14: Ring Plier Details (Truarc® Pliers)		
Orifice	Model No.	Tip No.
D thru H	0700	0700-09
J and K	0700	0704-10
L and N	0700	0704-12
P and Q	0900	0900-12
R and T	1100	1100-15c

Note: Available from Waldes Kohinoor, Inc. Long Island City, New York 11101

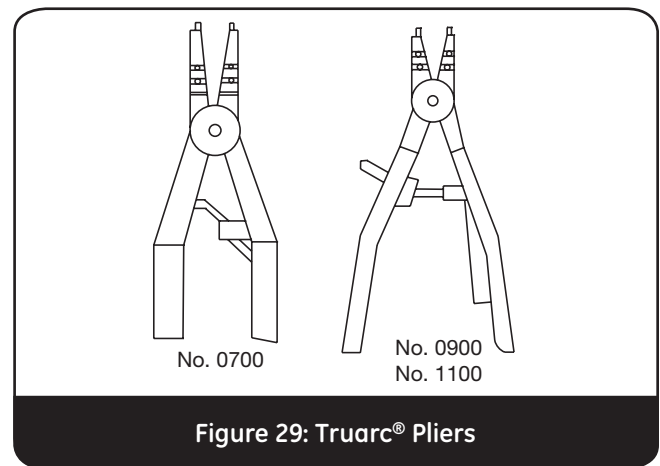

Figure 29: Truarc® Pliers

XX. Maintenance Tools and Supplies (Contd.)

C. Lap Rings

For reconditioning nozzles and Thermodisc discs (Table 15)

Table 15: Lap Ring Dimensions			
Orifice	in.	mm	Part No.
D thru J	1.750	44.45	1672805
K & L	2.625	66.68	1672807
M & N	3.813	96.85	1672808
P	4.188	106.38	167210
Q & R	5.500	139.70	167212
T	7.000	177.80	167213

D. Lap Plate

Part No. 0439002, for reconditioning all Lap Rings used for these valves .

E. Lapping Compounds

Table 16: Lapping Compounds					
Brand	Grade	Grit	Lapping Function	Size Container	Part No
Clover	1A	320	General	4 oz.	199-3
Clover	3A	500	Finishing	4 oz.	199-4
Kwik-Ak-Shun	-	1000	Polishing	1lb	199-11
				2 oz.	199-12

XXI. Replacement Parts Planning

A. Service Parts Inventory Planning

The basic objectives in formulating a service parts inventory philosophy is to provide prompt valve service capability, thus preventing maintenance outage time extensions. To accomplish this, it is necessary to have immediate availability of the proper inventory of service parts for optimum valve quantities. This can be achieved at a minimum of cost by defining the inventory on a frequency of need basis.

To assist towards this objective, GE recommends that the following guidelines be utilized to establish meaningful inventory levels.

1. Identify the total number of valves in service by size, type number, temperature class, and serial number.
2. Identify the frequency of replacement tendency of specific parts.

Class I - parts most frequently replaced

Class II - parts less frequently replaced, but critical in the event of an emergency requirement.

Class III - parts seldom replaced

Class IV - hardware (e.g. nuts, bolts, pins, cap components, etc.)

Class V - parts practically never requiring replacement
3. "Need probability coverage" is defined as the probable percent of total, uninterrupted operational time which can be expected by stocking predetermined valve component classifications. Determine "need probability coverage" which is compatible with a specific company's operational objectives and service parts inventory investment philosophy. Then relate "need probability coverage" to parts classifications which will satisfy that need. Guidelines are as listed in Table 17.

Parts Classification	Need Probability Coverage
Class I	70 percent
Class II	85 percent
Class III	95 percent
Class IV	99 percent

4. Consult recommended spare parts list by valve type to determine quantity of parts for valves to be covered by the inventory plan.
5. Select parts and specify quantities.

B. Ordering Essentials

When ordering replacement parts, the order should state:

1. Part name
2. Part number (if known)
3. Quantity
4. Valve size
5. Valve type number
6. Valve serial number
7. When ordering spring assemblies, also state valve set pressure and temperature.

Example of valve identification:

Type number: 3" (76.20 mm) 1910-30K/P1

Serial number: TD 07961

The correct part names can be obtained from Figure 1 thru 8. Other information may be obtained from the name plate (see Figure 30 31 and 32). If the nameplate has been lost or defaced, the serial number and valve type number can be found stamped into the edge of the outlet flange.

XXI. Replacement Parts (Contd.)

CERTIFIED BY			
DRESSER Consolidated			
TYPE			
SIZE	SERIAL NO.		
SET PRESS.	PSI	LIFT	IN
CAP.	LBS / HR AT		°F
B/M	DATE		

Figure 30:
ASME Code Section I Nameplate

CERTIFIED BY			
DRESSER Consolidated			
TYPE			
SIZE	SERIAL NO.		
SET PRESS.	PSI	CDTP	PSI
TOTAL BACK PRESSURE	PSI	TEMP.	°F
CAP.	LBS/HR SAT. STEAM	STD. CU. FT./ MIN. AIR	
CAP.	GPM WATER	STD. CU. FT./ MIN. N. G	
B/M	DATE		

Figure 31:
ASME Code Section VIII Nameplate

RESTRICTED LIFT VALVE	
RESTRICTED BY	
[REDACTED]	
RESTRICTED CAPACITY	[REDACTED]
RESTRICTED CAPACITY LIFT	[REDACTED] IN
<p>THE ACTUAL DISCHARGE CAPACITY MAY EXCEED THAT STAMPED ON THE VALVE. THIS SHOULD BE CONSIDERED AND THE MANUFACTURER CONSULTED WHEN SIZING THE DISCHARGE SYSTEM.</p>	
CODE CASE	[REDACTED]

Figure 32

Your safety is our business!

GE has authorized no company nor individual to manufacture replacement parts for our valve products.

When ordering replacement parts, please specify in your purchase order: "All parts must be documented as new and sourced from GE".

Be sure! Be sure!

XXII. Genuine Consolidated Parts

Each time replacement parts are needed, keep these points in mind:

- GE designed the parts.
- GE guarantees the parts.
- Consolidated valve products have been in service since 1879.
- GE has worldwide service.
- GE has fast response availability for parts.

XXIII. Recommended Spare Parts

**Table 18: Steam Internal Design - Safety Relief Valves
1900 Conventional / P1 & P3 and 1900-30 Bellows / P1**

Class	Part Name	Interchangeability P1, P3	C - Conventional B - Bellows	Qty. Parts/Same Valves in Service	Need Probability Coverage
Class I	Thermodisc	P1, P3	C & B	1/3	70 percent
	Nozzle	P1, P3	C & B	1/10	
	Bellows	P1	B	1/3	
	Adjusting Ring Pin	P1, P3	C & B	1/3	
	Disc Holder Ring	P1, P3	C & B	1/1	
	Disc Holder Retainer Ring	P1,P3	C & B	1/5	
	Spindle Retainer	P1	B	1/1	
	Gasket (Set)	-	-	-	
	(1) Cap Gasket	P1	C & B	1/1	
	(1) Bonnet Gasket	P1	C & B	1/1	
	(1) Guide Gasket	P1,P3	C & B	1/1	
	(1) Adj. Ring Pin Gasket	P1, P3	C & B	1/1	
(1) Bellows Gasket	P1	B	1/1		
Class II	Disc Holder	P1, P3	C & B	1/6	85 percent
	Spindle	P1, P3	C & B	1/6	
	Guide	P1, P3	C & B	1/6	
	Studs, Base	P1, P3	C & B	1 set/6	
	Nuts, Base Stud	P1, P3	C & B	1 set/6	
Class III	Adjusting Ring	P1, P3	C & B	1/10	95 percent
	Spring Assembly	-	-	-	
	(1) Spring ¹	P1, P3	C & B	1/10	
	(1) Spring Washer (U)	P1, P3	C & B	1/10	
	(1) Spring Washer (L)	P1, P3	C & B	1/10	
	Adjusting Screw	P1, P3	C & B	1/10	
Class IV	Adjusting Screw Lock Nut	P1, P3	C & B	1/10	99 percent
	Cap (Select One):	-	-	-	
	Packet Lever Assembly	P1	C & B	1/10	
	(1) Cap Assembly				
	(1) Release Nut				
	(1) Release Lock Nut				
	Plain Lever Assembly	P1, P3	C & B	1/10	
	(1) Cap Assembly				
	(1) Release Nut				
	(1) Release Lock Nut				
Limit Washer ²	P1, P3	C & B	1/10		

Note 1: If set pressure change is required, consult GE for the spring number.

Note 2: Used only in the D & E orifices, machine per instructions on Section XIV.A.

XIX. Manufacturer's Field Service & Repair Program

A. Field Service

Utilities and Process Industries expect and demand service at a moment's notice. GE's Field Service can be depended upon for prompt response, even in extreme off-hour emergency situations.

GE maintains the largest and most competent field service staff in the industry. Service Engineers are located at strategic points throughout the United States to respond to customer's requirements for service. Each Service Engineer is factory trained and long experienced in servicing safety valves. GE's Service Engineers restore disc and seat bushing critical dimensions which affect valve performance, and are capable of modernizing valves in the field.

It is highly recommended that the professional talents of a GE Field Service Engineer be employed to make final field adjustments during the initial setting of all Consolidated Safety Valves.

B. Factory Repair Facilities

GE's Consolidated factory maintains a Repair Center. The repair department, in conjunction with the manufacturing facilities, is equipped to perform specialized repairs and product modifications, e.g., bushing replacements, hydroset calibrations, electromatic relief valve repairs, etc.

C. Safety Valve Maintenance Training

Rising costs of maintenance and repair in the Utility and Process Industries indicate the need for trained maintenance personnel. GE conducts service seminars that can help your maintenance and engineering personnel to reduce these costs.

Seminars, conducted either at your site, or at our manufacturing plant, provide participants with an introduction to the basics of preventative maintenance. These seminars help to minimize downtime, reduce unplanned repairs and increase valve safety. While they do not make "instant" experts, they do provide the participants with "Hands On" experience with Consolidated valves. The seminar also includes valve terminology and nomenclature, component inspection, trouble shooting, setting and testing, with emphasis on the ASME Boiler and Pressure Vessel Code.

For further information, please contact your local Green Tag Center or GE's Consolidated Training Manager at +1 (281) 542-3646.

Notes:

Notes:

DIRECT SALES OFFICE LOCATIONS

AUSTRALIA

Brisbane
Phone: +61-7-3001-4319
Fax: +61-7-3001-4399

Perth
Phone: +61-8-6595-7018
Fax: +61-8-6595-7299

Melbourne
Phone: +61-3-8807-6002
Fax: +61-3-8807-6577

BELGIUM
Phone: +32-2-344-0970
Fax: +32-2-344-1123

BRAZIL
Phone: +55-19-2104-6900

CHINA
Phone: +86-10-5689-3600
Fax: +86-10-5689-3800

FRANCE
Courbevoie
Phone: +33-1-4904-9000
Fax: +33-1-4904-9010

GERMANY
Ratingen
Phone: +49-2102-108-0
Fax: +49-2102-108-111

INDIA
Mumbai
Phone: +91-22-8354790
Fax: +91-22-8354791

New Delhi
Phone: +91-11-2-6164175
Fax: +91-11-5-1659635

ITALY

Phone: +39-081-7892-111
Fax: +39-081-7892-208

JAPAN
Tokyo
Phone: +81-03-6871-9008
Fax: +81-03-6890-4620

KOREA
Phone: +82-2-2274-0748
Fax: +82-2-2274-0794

MALAYSIA
Phone: +60-3-2161-0322
Fax: +60-3-2163-6312

MEXICO
Phone: +52-55-3640-5060

THE NETHERLANDS
Phone: +31-15-3808666
Fax: +31-18-1641438

RUSSIA
Veliky Novgorod
Phone: +7-8162-55-7898
Fax: +7-8162-55-7921

Moscow
Phone: +7 495-585-1276
Fax: +7 495-585-1279

SAUDI ARABIA
Phone: +966-3-341-0278
Fax: +966-3-341-7624

SINGAPORE
Phone: +65-6861-6100
Fax: +65-6861-7172

SOUTH AFRICA

Phone: +27-11-452-1550
Fax: +27-11-452-6542

SOUTH & CENTRAL
AMERICA AND THE CARIBBEAN
Phone: +55-12-2134-1201
Fax: +55-12-2134-1238

SPAIN
Phone: +34-93-652-6430
Fax: +34-93-652-6444

UNITED ARAB EMIRATES
Phone: +971-4-8991-777
Fax: +971-4-8991-778

UNITED KINGDOM
Bracknell
Phone: +44-1344-460-500
Fax: +44-1344-460-537

Skelmersdale
Phone: +44-1695-526-00
Fax: +44-1695-526-01

UNITED STATES
Massachusetts
Phone: +1-508-586-4600
Fax: +1-508-427-8971

Corpus Christi, Texas
Phone: +1-361-881-8182
Fax: +1-361-881-8246

Deer Park, Texas
Phone: +1-281-884-1000
Fax: +1-281-884-1010

Houston, Texas
Phone: +1-281-671-1640
Fax: +1-281-671-1735

www.geoilandgas.com/valves

*Denotes a trademark of the General Electric Company.

© 2016 General Electric Company. All rights reserved.

Other company names and product names used in this document are the registered trademarks or trademarks of their respective owners.

