

Consolidated* **1511** Series Safety Valve

Maintenance Manual (Rev.C)



**BAKER
HUGHES**
a GE company



THESE INSTRUCTIONS PROVIDE THE CUSTOMER/OPERATOR WITH IMPORTANT PROJECT-SPECIFIC REFERENCE INFORMATION IN ADDITION TO THE CUSTOMER/OPERATOR'S NORMAL OPERATION AND MAINTENANCE PROCEDURES. SINCE OPERATION AND MAINTENANCE PHILOSOPHIES VARY, BHGE (BAKER HUGHES, A GE COMPANY AND ITS SUBSIDIARIES AND AFFILIATES) DOES NOT ATTEMPT TO DICTATE SPECIFIC PROCEDURES, BUT TO PROVIDE BASIC LIMITATIONS AND REQUIREMENTS CREATED BY THE TYPE OF EQUIPMENT PROVIDED.

THESE INSTRUCTIONS ASSUME THAT OPERATORS ALREADY HAVE A GENERAL UNDERSTANDING OF THE REQUIREMENTS FOR SAFE OPERATION OF MECHANICAL AND ELECTRICAL EQUIPMENT IN POTENTIALLY HAZARDOUS ENVIRONMENTS. THEREFORE, THESE INSTRUCTIONS SHOULD BE INTERPRETED AND APPLIED IN CONJUNCTION WITH THE SAFETY RULES AND REGULATIONS APPLICABLE AT THE SITE AND THE PARTICULAR REQUIREMENTS FOR OPERATION OF OTHER EQUIPMENT AT THE SITE.

THESE INSTRUCTIONS DO NOT PURPORT TO COVER ALL DETAILS OR VARIATIONS IN EQUIPMENT NOR TO PROVIDE FOR EVERY POSSIBLE CONTINGENCY TO BE MET IN CONNECTION WITH INSTALLATION, OPERATION OR MAINTENANCE. SHOULD FURTHER INFORMATION BE DESIRED OR SHOULD PARTICULAR PROBLEMS ARISE WHICH ARE NOT COVERED SUFFICIENTLY FOR THE CUSTOMER/OPERATOR'S PURPOSES THE MATTER SHOULD BE REFERRED TO BHGE.

THE RIGHTS, OBLIGATIONS AND LIABILITIES OF BHGE AND THE CUSTOMER/OPERATOR ARE STRICTLY LIMITED TO THOSE EXPRESSLY PROVIDED IN THE CONTRACT RELATING TO THE SUPPLY OF THE EQUIPMENT. NO ADDITIONAL REPRESENTATIONS OR WARRANTIES BY BHGE REGARDING THE EQUIPMENT OR ITS USE ARE GIVEN OR IMPLIED BY THE ISSUE OF THESE INSTRUCTIONS.

THESE INSTRUCTIONS ARE FURNISHED TO THE CUSTOMER/OPERATOR SOLELY TO ASSIST IN THE INSTALLATION, TESTING, OPERATION, AND/OR MAINTENANCE OF THE EQUIPMENT DESCRIBED. THIS DOCUMENT SHALL NOT BE REPRODUCED IN WHOLE OR IN PART WITHOUT THE WRITTEN APPROVAL OF BHGE.

Conversion Table

All the United States Customary System (USCS) values are converted to metric values using the following conversion factors:

USCS Unit	Conversion Factor	Metric Unit
in.	25.4	mm
lb.	0.4535924	kg
in ²	6.4516	cm ²
ft ³ /min	0.02831685	m ³ /min
gal/min	3.785412	L/min
lb/hr	0.4535924	kg/hr
psig	0.06894757	barg
ft lb	1.3558181	Nm
°F	5/9 (°F-32)	°C

Note: Multiply USCS value with conversion factor to get metric value.

NOTICE

For valve configurations not listed in this manual, please contact your local Green Tag* Center for assistance.

Table of Contents

I.	Product Safety Sign and Label System	5
II.	Safety Alerts	6
III.	Safety Notice	7
IV.	Warranty Information	8
V.	Valve Terminology	8
VI.	Storage and Handling Prior to Installation	10
VII.	Introduction	10
VIII.	Consolidated Safety Valve Type 1511	11
IX.	Recommended Installation Practices	
	A. General Requirements	12
	B. Outdoor Safety Valve Installation	13
X.	Disassembly of 1511 Series Safety Valve	14
XI.	Maintenance Instructions	
	A. General Information	14
	B. Machining	15
	C. Lapping Procedures	15
	D. Reconditioning a Ring Lap	16
	E. Spindle Runout	16
	F. Spring and Spring Washers	17
	G. Lift Restrictor	17
XII.	Inspection and Part Replacement	
	A. General Information	17
	B. Specific Steps	17
XIII.	Reassembly	20
XIV.	Setting and Testing	
	A. Steam Testing Procedures	21
	B. Hydrostatic Testing & Gagging	23
	B.1 General Information	23
	B.2 Application of Test Gags (All Pressures)	24
	C. Presetting the Adjusting Rings	24
	D. Electronic Valve Testing (EVT)	25
XV.	Trouble Shooting the 1511 Series Safety Valve	26
XVI.	Maintenance Tools and Supplies	27
XVII.	Replacement Parts Planning	
	A. Basic Guidelines	28
	B. Identification and Ordering Essentials	28
XVIII.	Consolidated Genuine Parts	29
XIX.	Recommended Spare Parts	30
XX.	Manufacturer's Field Service, Repair and Training Program	
	A. Field Service	31
	B. Repair Facilities	31
	C. Maintenance Training	31

I. Product Safety Sign and Label System

If and when required, appropriate safety labels have been included in the rectangular margin blocks throughout this manual. Safety labels are vertically oriented rectangles as shown in the *representative examples* (below), consisting of three panels encircled by a narrow border. The panels can contain four messages that communicate:

- The level of hazard seriousness
- The nature of the hazard
- The consequence of human, or product, interaction with the hazard.
- The instructions, if necessary, on how to avoid the hazard.

The top panel of the format contains a signal word (DANGER, WARNING, CAUTION or ATTENTION) which communicates the level of hazard seriousness.

The center panel contains a pictorial which communicates the nature of the hazard, and the possible consequence of human or product interaction with the hazard. In some instances of human hazards the pictorial may depict what preventive measures to take, such as wearing protective equipment.

The bottom panel may contain an instruction message on how to avoid the hazard. In the case of human hazard, this message may also contain a more precise definition of the hazard, and the consequences of human interaction with the hazard, than can be communicated solely by the pictorial.

①

DANGER – Immediate hazards which **WILL** result in severe personal injury or death.

②

WARNING – Hazards or unsafe practices which **COULD** result in severe personal injury or death.

③

CAUTION – Hazards or unsafe practices which **COULD** result in minor personal injury.

④

ATTENTION – Hazards or unsafe practices which **COULD** result in product or property damage.



II. Safety Alerts



Follow all plant safety regulations, but be sure to observe the following:

- Always lower the working pressure before making any valve adjustment. When making ring adjustments, always gag the valve before making the adjustment. This will avoid possible personal injury.
- Do not stand in front of the discharge side of a safety valve when testing or operating.
- Hearing and eye protection should be used when testing or operating a valve.
- Wear protective clothing. Hot water can burn and superheated steam is not visible.
- When removing the safety valve during disassembly, stand clear and/or wear protective clothing to prevent exposure to splatter or any corrosive process medium, which may have been trapped inside the valve. Ensure the valve is isolated from system pressure before the valve is removed.
- Exercise care when examining a safety valve for leakage.
- Prior to each actuation, assure that no personnel are near the valve. Steam escaping from the valve during actuation can possibly cause personal injury.
- When popping a safety valve for the first time or after refurbishment, always be prepared to actuate the valve with the lever while standing in a safe place away from the valve. This may be done by fixing a rope to the lever for actuating the valve from a distance.
- Striking a valve which is under pressure can cause premature actuation. Never tamper with the valve when system pressure is near the valve set pressure.
- Before performing any machining on valve parts, consult BHGE or its authorized representative. Deviation from critical dimensions can adversely affect valve performance.

III. Safety Notice

Proper installation and startup is essential to the safe and reliable operation of all valve products. The relevant procedures recommended by BHGE and described in these instructions are effective methods of performing the required tasks.

It is important to note that these instructions contain various “safety messages” which should be carefully read in order to minimize the risk of personal injury or the possibility that improper procedures will be followed which may damage the involved product or render it unsafe. It is also important to understand that these “safety messages” are not exhaustive. BHGE cannot possibly know, evaluate, and advise any customer of all of the conceivable ways in which tasks might be performed, or of all possible hazardous consequences. Consequently, BHGE has not undertaken any such broad evaluation and, thus, anyone who uses a procedure and/or tool that is not recommended by BHGE, or deviates from BHGE recommendations must be thoroughly satisfied that neither personal safety, nor valve safety, will be jeopardized by the method and/or tools selected. If not so satisfied, contact BHGE if there are any questions relative to tools/methods.

The installation and start-up of valves and/or valve products may involve proximity to fluids at extremely high pressure and/or temperature. Consequently, every precaution should be taken to prevent injury to personnel during the performance of any procedure. These precautions should consist of, but are not limited to, ear drum protection, eye protection, and the use of protective clothing, (i.e., gloves, etc.) when personnel are in, or around, a valve work area. Due to the various circumstances and conditions in which these operations may be performed on Consolidated products, and the possible hazardous consequences of each way, BHGE cannot possibly evaluate all conditions that might injure personnel or equipment. Nevertheless, BHGE does offer certain Safety Precautions, listed in Section II, for customer information only.

It is the responsibility of the purchaser or user of BHGE valves/equipment to adequately train all personnel who will be working with the involved valves/equipment. For more information on training schedules, call (281) 542-3646. Further, prior to working with the involved valves/equipment, personnel who are to perform such work should become thoroughly familiar with the contents of these instructions.



IV. Warranty Information

Warranty Statement - BHGE warrants that its products and work will meet all applicable specifications and other specific product and work requirements and will be free from defects in material and workmanship. Refer to BHGE's Standard Terms of Sale, or specific contract for complete details on warranty and limitation of remedy and liability.

Defective and nonconforming items must be held for BHGE's inspection and returned to the original F.O.B. point upon request.

Incorrect Selection or Misapplication of Products

- BHGE cannot be responsible for customer's incorrect selection or misapplication of our products.

Unauthorized Repair Work - BHGE has not authorized any non-BHGE affiliated repair companies, contractors or individuals to perform modifications or services on new products or field repaired products of its manufacture. Therefore, customers contracting for such services or performing such services on their own do so at their own risk.

Unauthorized Removal of Seals - All new valves and valves repaired in the field by BHGE's affiliated repair companies are sealed to assure the customer of our guarantee against defective workmanship. Unauthorized removal and/or breakage of this seal will negate our warranty.

V. Valve Terminology

(Paraphrased from ASME's PTC 25)

- **Back Pressure**
Back pressure is the static pressure existing at the outlet of a safety valve device due to pressure in the discharge system.
- **Blowdown**
Blowdown is the difference between actual popping pressure of a safety valve and actual reseating pressure expressed as a percentage of set pressure, or in pressure units.
- **Bore Area**
Bore area is the minimum cross-sectional area of the seat bushing.
- **Bore Diameter**
Bore diameter is the minimum diameter of the seat bushing.
- **Built-Up Back Pressure**
Pressure existing at the outlet of a safety valve while it is open and flowing through a discharge system.
- **Chatter**
Chatter is abnormal, rapid reciprocating motion of the moveable parts of a safety valve, in which the disc contacts the seat.
- **Closing Pressure**
Closing pressure is the value of decreasing inlet static pressure at which the valve disc re-establishes contact with the seat, or at which lift becomes zero.
- **Disc**
A disc is the pressure containing moveable member of a safety valve which effects closure.
- **Inlet Size**
Inlet size is the nominal pipe size of the inlet of a safety valve, unless otherwise designated.
- **Leak Test Pressure**
Leak test pressure is the specified inlet static pressure at which a quantitative seat leakage test is performed in accordance with a standard procedure.
- **Lift**
Lift is the actual travel of the disc away from closed position when a valve is relieving.
- **Lifting Device**
A lifting device is a device for manually opening a safety valve, by the application of external force to lessen the spring loading which holds the valve closed.

V. Valve Terminology

- **Seat Bushing**

A seat bushing is the pressure containing element which constitutes the inlet flow passage and includes the fixed portion of the seat closure.
- **Outlet Size**

Outlet size is the nominal pipe size of the outlet passage of a safety valve, unless otherwise designated.
- **Overpressure**

Overpressure is a pressure increase over the set pressure of a safety valve, usually expressed as a percentage of set pressure.
- **Popping Pressure**

Popping pressure is the value of increasing inlet static pressure at which the disc moves in the opening direction at a faster rate as compared with corresponding movement at higher or lower pressures. It applies only to safety or safety relief valves on compressible fluid service.
- **Pressure Containing Member**

A pressure containing member of a safety valve is a part which is in actual contact with the pressure media in the protected vessel.
- **Pressure Retaining Member**

A pressure retaining member of a safety valve is a part which is stressed due to its function in holding one or more pressure containing members in position.
- **Rated Lift**

Rated lift is the design lift at which a valve attains its rated relieving capacity.
- **Safety Valve**

A safety valve is a pressure relief valve actuated by inlet static pressure and characterized by rapid opening or pop action.
- **Set Pressure**

Set pressure is the value of increasing inlet static pressure at which a safety valve displays the operational characteristics as defined under "Popping Pressure." It is one value of pressure stamped on the safety valve.
- **Seat**

A seat is the pressure containing contact between the fixed and moving portions of the pressure containing elements of a valve.
- **Seat Diameter**

Seat diameter is the smallest diameter of contact between the fixed and moving members of the pressure containing elements of a valve.
- **Seat Tightness Pressure**

Seat tightness pressure is the specific inlet static pressure at which a quantitative seat leakage test is performed in accordance with a standard procedure.
- **Simmer**

Simmer is the audible or visible escape of fluid between the seat and disc at an inlet static pressure below the popping pressure and at no measurable capacity. It applies to safety valves on compressible fluid service.
- **Warn**

See "Simmer" (definition above).

VI. Storage and Handling Prior to Installation

Safety valves should be stored in a dry environment to protect them from the weather. They should not be removed from the skids or crates until immediately prior to installation. Flange protectors and sealing plugs should remain installed until just prior to installation.

Safety valves, either crated or uncrated, should never be subjected to sharp impact. This would be most likely to occur by bumping or dropping during loading or unloading from a truck or while moving with a power conveyor, such as a fork lift truck. The valve, either crated or uncrated, should always be kept with the inlet down (i.e., never laid on its side), to prevent misalignment and damage to internals. Even crated valves should always be lifted with the inlet down.

Uncrated valves should be moved or hoisted by wrapping a chain or sling, around the discharge neck, then around the upper yoke structure, in such manner as will ensure that the valve is in vertical position during lift, (i.e., not lifted in horizontal position). Never lift the full weight of the valve by the lifting lever. Never hook to the spring to lift. When safety valves are uncrated and the flange protectors removed, immediately prior to installation, meticulous care should be exercised to prevent dirt from entering the outlet port while bolting in place.

While hoisting to the installation, care should be exercised to prevent bumping the valve against steel structures and other objects.

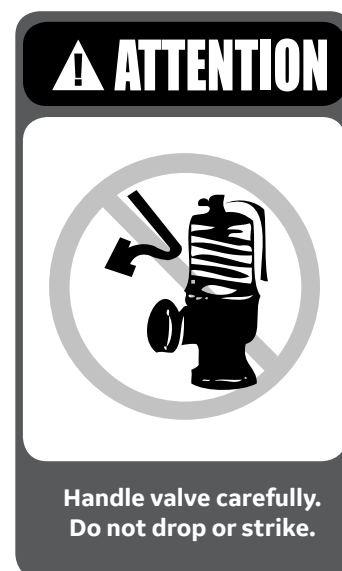

VII. Introduction

The "safety valve" is the final safeguard between a controlled boiler and a catastrophic explosion. In an over-pressure situation, the pressure in the valve inlet increases until the force on the disc exerted by the system pressure equals the force exerted by the spring. This causes the safety valve to pop, or lift, relieving the excess steam until the system pressure is reduced to the desired level.

BHGE's Consolidated safety valves have been a leader in the industry since 1879, thus offering over a century of experience in the valve industry.

BHGE's history of dependable and reliable valve service assures that today's products and designs are consistent with industry's current requirements. Rigid manufacturing standards controlled by an ASME-approved Quality Control Program ensure that each valve will be manufactured in accordance with established design criteria and tested for functional performance. This quality controlled manufacturing and test program assures that each valve manufactured will provide long and reliable service.

VIII. Consolidated 1511 Series Safety Valve

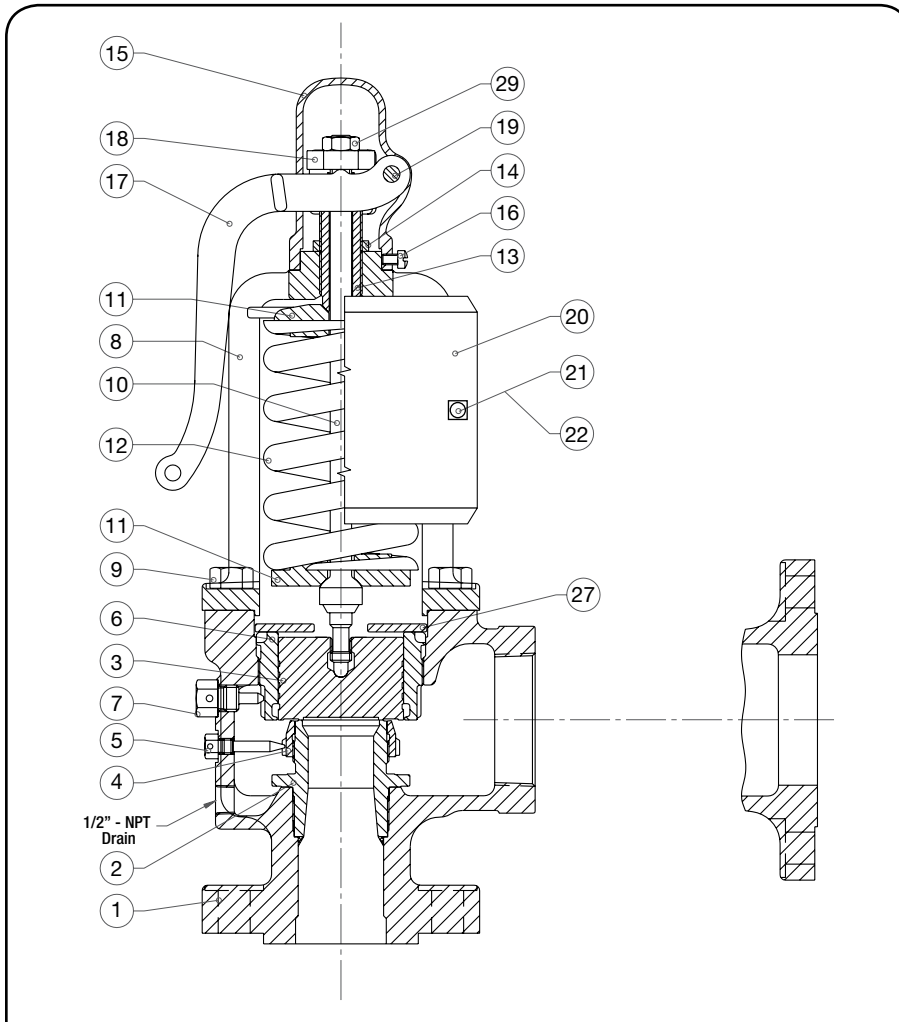
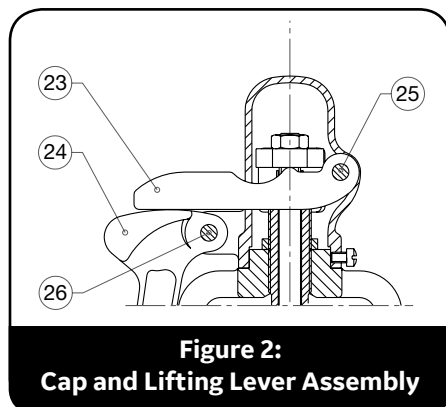

Figure 1: 1511 Series Safety Valve



**Figure 2:
Cap and Lifting Lever Assembly**

Part No.	Nomenclature
1	Base
2	Seat Bushing
3	Disc
4	Lower Adj. Ring
5	Lower Adj. Ring Pin
6	Upper Adj. Ring
7	Upper Adj. Ring Pin
8	Yoke
9	Yoke Cap Screws
10	Spindle Assembly
11	Spring Washer
12	Spring
13	Compression Screw
14	Compression Screw Nut
15	Cap
16	Cap Set Screw
17	Lever
18	Release Nut
19	Lever Pin
20	Spring Cover
21	Cover Bolt
22	Cover Nut
23	Top Lever
24	Drop Lever
25	Top Lever Pin
26	Drop Lever Pin
27	Floating Washer
28	Lift Stop ⁽¹⁾
29	Spindle Locknut

Note 1: Not Shown. Required for 5-26 psi (0.34-1.79 bar).

IX. Recommended Installation Practices



A. General Requirements

The safety valve shall be connected to the boiler in a vertical position independent of any other steam connection and attached as close as possible to the boiler. Intervening pipe or fittings shall be no longer than the face-to-face dimension of the corresponding tee fitting of the same diameter and pressure under the corresponding American Standard as set forth by the ASME.

Thoroughly clean the inlet of the valve before installation and be sure that the proper gasket is used. Tighten bolts evenly. For 1510 and 1511 Series, the flange bolting shall be ASTM A307 Grade B per ASME B16.1, and shall be torqued not to exceed the values shown in Table 1.

The safety valve shall be free from external stresses transmitted from the discharge piping. Figure 3 illustrates a recommended design allowing for ample clearance to take care of thermal expansion. The riser pipe should be large enough to accommodate the full capacity of the valve without causing steam to escape by flowing backward through the drip pan. In no case should the pipe connected to the valve be of a smaller size than the valve outlet.

Table 1: 1510 & 1511 Series Safety Valve Inlet Flange Bolting Torque

Orifice	Inlet Flange Size		Inlet Flange Bolt Size		Bolting Torque (ft-lbs)		Bolting Torque (Nm)	
	inches	mm	inches	mm	Dry	Lubricated	Dry	Lubricated
H	1 1/2	38.1	3/4	19.1	110	85	149	115
	2	50.8	5/8	15.9	60	45	81	61
	2 1/2	63.5	3/4	19.1	110	85	149	115
	3	76.2	3/4	19.1	110	85	149	115
J	1 1/2	38.1	3/4	19.1	110	85	149	115
	2	50.8	5/8	15.9	60	45	81	61
	2 1/2	63.5	3/4	19.1	110	85	149	115
	3	76.2	3/4	19.1	110	85	149	115
K	2	50.8	5/8	15.9	60	45	81	61
	2 1/2	63.5	3/4	19.1	110	85	149	115
	3	76.2	3/4	19.1	110	85	149	115
	3 1/2	88.9	3/4	19.1	110	85	149	115
	4	101.6	3/4	19.1	110	85	149	115
L	2 1/2	63.5	3/4	19.1	110	85	149	115
	3	76.2	3/4	19.1	110	85	149	115
	3 1/2	88.9	3/4	19.1	110	85	149	115
	4	101.6	3/4	19.1	110	85	149	115
M	3	76.2	3/4	19.1	110	85	149	115
	3 1/2	88.9	3/4	19.1	110	85	149	115
	4	101.6	3/4	19.1	110	85	149	115
	4 1/2	114.3	3/4	19.1	110	85	149	115
N	4	101.6	3/4	19.1	110	85	149	115
P	4	101.6	3/4	19.1	110	85	149	115
Q	6	152.4	3/4	19.1	110	85	149	115

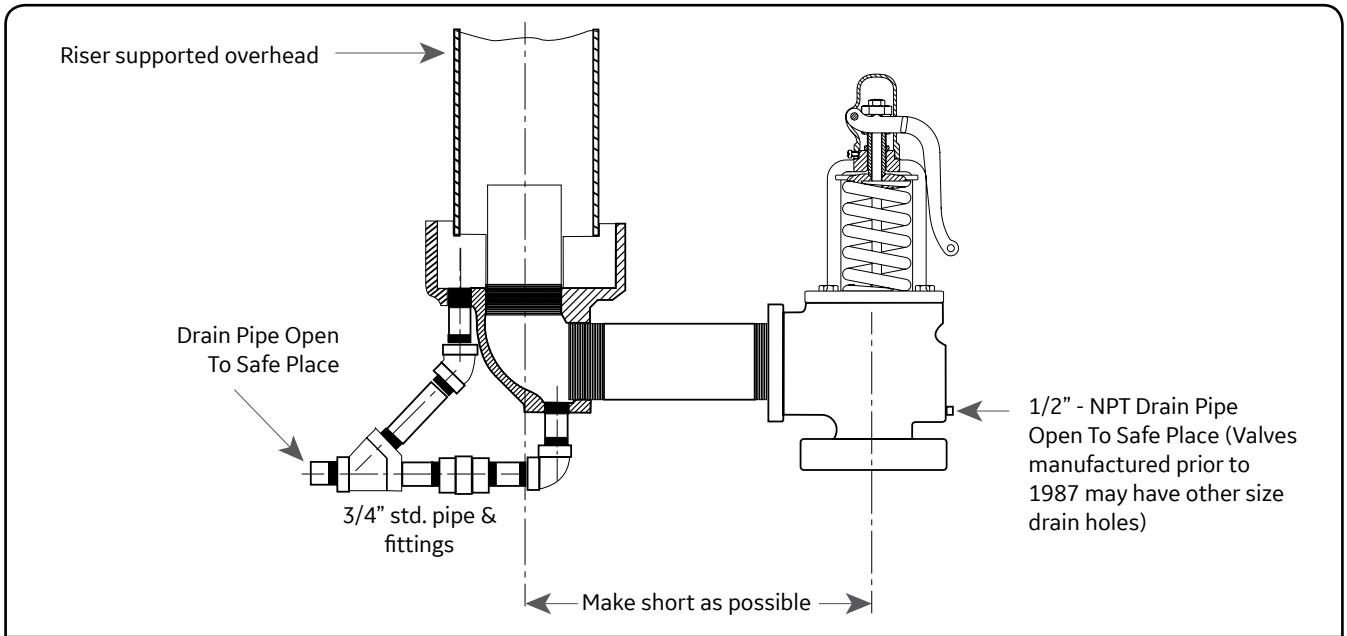

Figure 3: Recommended Installation for Discharge and Vent Piping

B. Outdoor Safety Valve Installation

When a safety valve is installed on an outdoor unit, it is advisable to insulate the valve body, including the inlet flange, up to the bottom of the yoke. The insulation will stabilize the valve body temperature preventing variation in the set pressure.

Valves must be readjusted if insulation is installed.

Weather shielding should be used to protect the spring and to minimize rain or snow from entering the valve body.

X. Disassembly of 1511 Series Safety Valve

Before removing the valve, be sure there is no steam pressure in the drum or header, then proceed as follows:

1. Remove the lower ring pin.
2. Turn the lower ring upwards counting the number of notches moved until contact is made with the disc. Record this information for use during reassembly.
3. Remove the lever pin and lever.
4. Loosen the cap screw(s) and remove the cap.
5. Remove the release nut and lock nut or cotter pin.
6. Measure the distance from the top of the spindle to the top of the compression screw. Record this for use in reassembly to restore the correct spring compression.
7. Loosen the compression screw lock nut and remove the compression screw.
8. Remove the cap screws or stud nuts holding the yoke to the base and raise the yoke over the spindle.
9. Remove the spring and spring washer assembly, record the spring number stamped in the spring. Mark the spring and washers top and bottom.
10. Lift the disc and spindle straight up to remove the disc from the valve body. Engage the drop through threads of the disc and unscrew it from the spindle.
11. Measure from the top of the combination guide and upper ring to the top of the bushing seat. Record this measurement for reassembly.
12. Remove the upper ring pin.
13. Remove the combination guide and upper ring by turning it upwards until the threads disengage.
14. Remove the lower adjusting ring. The valve is now completely disassembled.



XI. Maintenance Instructions

A. General Information

The 1511 safety valves are easily maintained. Normal maintenance usually involves:

- Disassembly
- Cleaning
- Component Inspection
- Lapping the Seats
- Reassembly
- Setting, Testing and Resealing the Valve

Occasionally, remachining the seat bushing may be

necessary to extend the service life of the valve. In any case, keep all parts for each valve together or marked to ensure that they are replaced in the same valve.

The following tools are recommended for normal maintenance and following remachining:

1. Flat lapping plate, (for resurfacing ring laps) - Part Number 0439004⁽¹⁾
2. Grinding Compounds⁽¹⁾
3. High temperature thread lubricant⁽¹⁾ - (Fel-Pro, Nickel Ease, or equivalent)
4. Two (2) ring laps per valve size and type⁽¹⁾

Note 1: See maintenance Tools and Supplies in Section XVI.

XI. Maintenance Instructions (Cont'd)

All of the above tools can be purchased from BHGE, with prices in effect at the time of delivery. It may not be necessary to use all of the ring laps at any one time, but having a sufficient supply on hand will save reconditioning time during a boiler outage. After the boiler is back in operation, the ring laps can be reconditioned on the flat lapping plate. Lapping compound, when used with ring

laps, wears off the seat surface on the disc or seat bushing, but it also wears off the flat surface of the ring lap. A lap should not be used on more than one valve without being reconditioned.

Lapping procedure for reconditioning the seating surfaces of the disc and seat bushing is outlined in Section XI.C.

B. Machining

After the parts have been determined to be reusable, proper machining technique must be employed in reestablishing disc and seat bushing dimensions.

On 1511 Series safety valves, the seat bushing should be

machined in the valve base to ensure proper parts alignment. When chucking the valve base or disc into a lathe, alignment must be within .001" (0.03 mm) total indicator runout at the points indicated in Figure 4 as "A", "B", and "C".

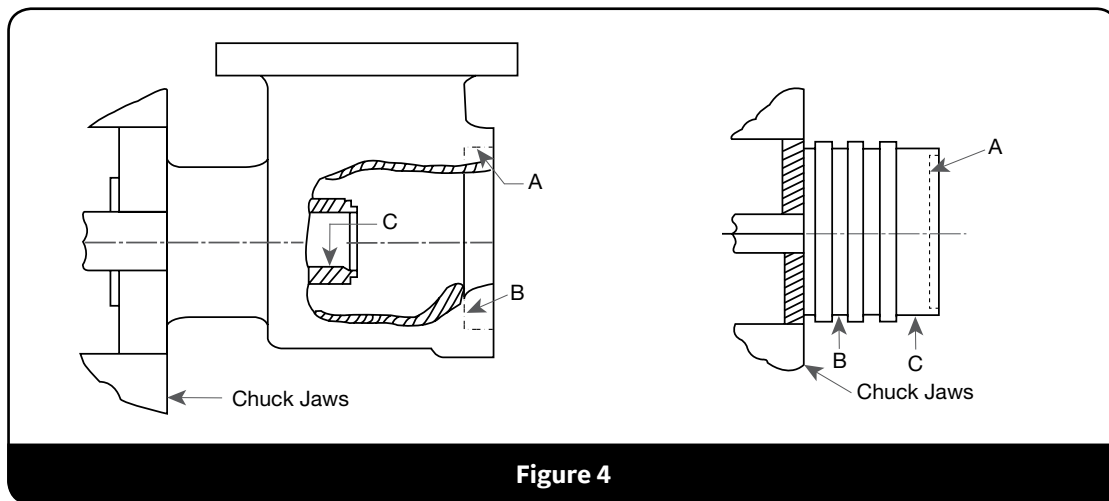

Figure 4

Note: See Section XII.B for rework dimensions for the Seat Bushing and Flat Solid Discs.

C. Lapping Procedures

1. General:

While the finer points of lapping may be considered a mechanical art, it is possible for the average mechanic to produce satisfactory results with some practice. No effort has been made in this manual to establish an exact procedure to cover each and every case because different people can achieve the same results using their own techniques.

The following materials will be of assistance when lapping bushing and/or disc seats:

- Two ring laps per valve
- 1-A Clover Grinding Compound
- 1000 grit Kwik-Ak-Shun Grinding Compound
- Lint free wipers for cleaning

2. Lapping the seat bushing or Disc Seat:

Before lapping the seat bushing and disc, use a fine grade sandpaper to lightly break the inner edge and outer edge of the bushing and disc seats. This chamfer should not exceed .002" (0.05mm). If the seating surfaces require extensive lapping or reconditioning, machining should be considered prior to lapping. See Inspection Section XII.B for criteria. Cover one flat surface of a ring lap with a thin coating of Clover 1-A Grinding Compound and gently set the lap on the seat surface. Thick coatings tend to round off edges of the seat. Lap using a slight oscillating motion in various directions. Control the motion of the lap to prevent the inside edge or outside edge of the lap from running off the seating surface, as this may cause the seat to become scratched or uneven.

XI. Maintenance Instructions (Cont'd)

3. Polishing or Finish Lapping:

Wipe off all used compound from the bushing or disc. Then use a flat, reconditioned ring lap, and light coating of Kwik-Ak-Shun™ 1000 Grit Grinding Compound to lap the seat. After lapping the seat for some time, wipe off all grinding compound from the ring lap (do not wipe off the compound on the bushing or disc seat). Using only the compound remaining on the seat, and the clean ring lap, continue to lap until it becomes difficult to move the ring lap on the seat. Again, wipe off the grinding compound from the ring lap only, and using the remaining compound on the seat continue to lap. The seating surface will become mirror like as the grinding compound is further broken down. Inspect the seat for cuts and scratches, repeat procedures as necessary to eliminate damage.

Once the seat surface is flat, clear and mirror-like, wipe all traces of grinding compound from the part and begin reconditioning the other seat. *Do not place the disc in a vice to accomplish lapping procedures, as damage can occur to disc surfaces and distortion to the seating surface.*

D. Reconditioning a Ring Lap

To recondition a ring lap, use Clover 1-A Compound on the lapping plate, and move the ring lap in a “figure 8” motion as shown in Figure 5. Continue lapping until all indications of wear (on both sides), are removed from the ring lap and a uniform grey surface is achieved. The ring lap is ready to use on the next valve. A lap that is flat within one light band is considered satisfactory for use. Information on the monochromatic light and optical flat is available upon request from the BHGE Field Service Department.

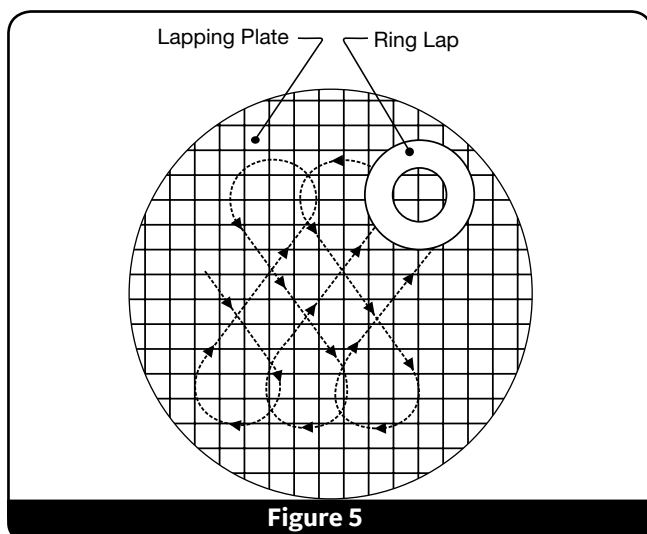

Figure 5

E. Spindle Runout

It is important that the spindle be kept very straight in order to transmit the spring force to the disc without lateral binding. Overgagging is one of the common causes of bent spindles. A method to check the essential working surfaces of the spindle is illustrated in Figure 6.

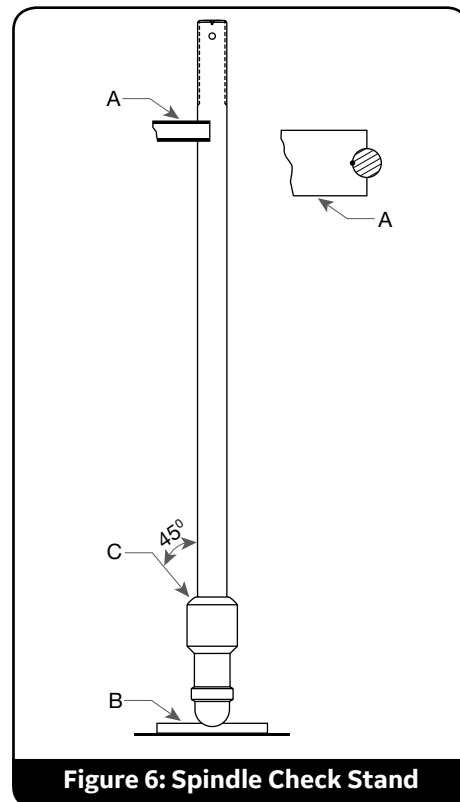

Figure 6: Spindle Check Stand

Using a spindle check stand (see Figure 6 as a reference), place the ball end of the spindle into a depression at the base “B” of the stand. Lean the upper portion of the spindle against the “V” block. It should be touching the spindle just below the threads on the upper portion of the

Table 2: Spindle Critical Dimensions

Orifice	C max.	
	in.	mm
H	.004	0.10
J	.004	0.10
K	.007	0.18
L	.007	0.18
M	.007	0.18
N	.007	0.18
P	.007	0.18
Q	.007	0.18

XI. Maintenance Instructions (Cont'd)

spindle. Using a machinists indicator on a 45° angle at spindle shoulder "C", rotate the spindle and read the Total Indicator Run out on the indicator. If the T.I.R is less than values shown in Table 2, the spindle may be returned to service. If the T.I.R is greater than these values, straighten the spindle using "V" blocks and a hydraulic press until the T.I.R is found to be acceptable.

Other parts of the spindle not used as working surfaces may run out considerably more than .007" (0.18 mm), but this should not be regarded as unacceptable. Although the upper thread end is not a working surface, excessive bending in this area could affect the accuracy of the Consolidated Hydroset device, and/or the Consolidated Electronic Valve Tester, if either of these devices is used to verify valve set pressure.

F. Spring and Spring Washers

Spring wire that is irregularly spaced, or the ends are not parallel, are sufficient causes for replacement. The spring washers are machined to fit the ends of the spring - there should be no more than a .030" (0.76 mm) clearance between the spring and the spring washer. If a spring is badly damaged by corrosion (flaking, pitting, or reduction in wire diameter), replace the spring with the proper spring. If the spring is unable to be identified contact your local Green Tag Center.

G. Lift Restrictor

On 1511 valves with set pressures of 26 psig (1.79 barg) and below will have a Lift Restrictor installed on the spindle stem, located inside the spring. Measure to verify minimum length for the appropriate orifice as per Table 3. If under the minimum length, replace the Lift Restrictor.

Orifice	L min	
	in.	mm
H	2.25	57.0
J	2.25	57.0
K	3.50	88.8
L	3.50	88.8
M	3.50	88.9
N	3.50	88.9
P	3.94	100.0
Q	5.00	127.0

XII. Inspection and Part Replacement

A. General Information

Once the valve is disassembled, the appropriate parts can be inspected for damage and their suitability for reuse.

B. Specific Steps

1. Inspect the guide inside diameter for egging, and ensure the inside surface is smooth. The threads on the outside must be in good condition to ensure the adjusting ring/guide will adjust when the valve is hot. If serious, large scale galling or ridges corresponding to the grooves in the disc are present, the part should be replaced.

2. **Disc :**

The 1511 Safety Valve is designed with a Flat Solid Disc (FSD) in either a low pressure (LP) or high pressure (HP) version (Refer to Table 4).

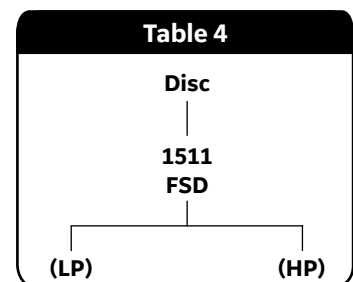

XII. Inspection and Part Replacement (Cont'd)

1511 Series Flat Solid Disc Machining Dimensions

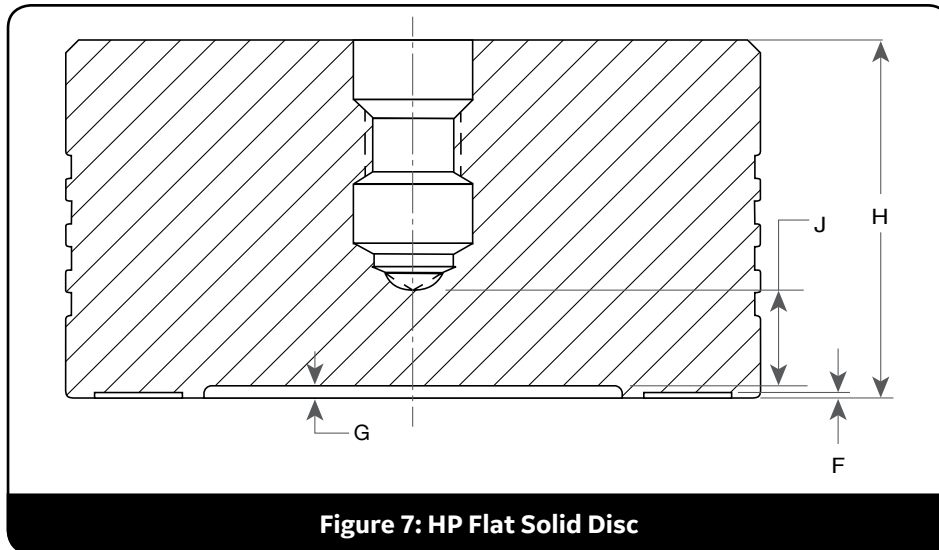

Figure 7: HP Flat Solid Disc

Table 5a: Replacement Criteria				
Orifice	H min.		J min.	
	in.	mm	in.	mm
H	1.140	28.96	.303	7.70
J	1.359	34.52	.348	8.84
K	1.453	36.91	.380	9.65
L	1.797	45.64	.412	10.46
M	1.859	47.22	.474	12.04
N	2.109	53.57	.536	13.61
P	2.739	69.57	.645	16.38
Q	3.547	90.09	.714	18.14

Note: Once a minimum dimension is met, disc is to be discarded.

Table 5b: Rework / Inspection Dimensions				
Orifice	F $+0.002/-0.003$ in. ($+0.05/-0.08$ mm) ⁽¹⁾		G	
	in.	mm	in.	mm
H	.028	0.71	.062 ± .007	1.57 ± 0.18
J	.028	0.71	.062 ± .005	1.57 ± 0.13
K	.028	0.71	.062 ± .007	1.57 ± 0.18
L	.028	0.71	.062 ± .007	1.57 ± 0.18
M	.028	0.71	.062 ± .007	1.57 ± 0.18
N	.028	0.71	.062 ± .007	1.57 ± 0.18
P	.039	0.99	.078 ± .007	1.98 ± 0.18
Q	.039	0.99	.107 $+0.003$ -0.002	2.72 $+0.08$ -0.05

Note 1: When (F) dimension is reduced to .015" (0.38 mm) for H – N orifices, or .026" (0.66 mm) for P – Q orifices, restore the dimensions indicated in Table 5b. Do not re-machine once minimum (H or J) dimensions are reached. Disc is to be discarded at this point.

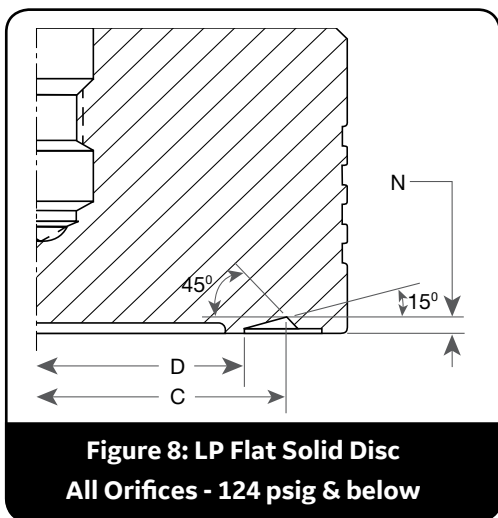

Figure 8: LP Flat Solid Disc
All Orifices - 124 psig & below

Table 6: Rework Inspection Dimensions ⁽¹⁾						
Orifice	C		D		N	
	in.	mm	in.	mm	in.	mm
H	1.552 ± .005	39.42 ± 0.13	1.349 ± .002	34.26 ± 0.05	.053 ± .002	1.35 ± 0.05
J	1.983 ± .005	50.37 ± 0.13	1.683 ± .002	42.75 ± 0.05	.056 $+0.002$ -0.003	1.42 $+0.05$ -0.08
K	2.372 ± .005	60.25 ± 0.13	1.977 ± .002	50.22 ± 0.05	.079 ± .002	2.01 ± 0.05
L	2.948 ± .005	74.88 ± 0.13	2.418 ± .002	61.42 ± 0.05	.096 ± .002	2.44 ± 0.05
M	3.307 ± .005	84.00 ± 0.13	2.722 ± .002	69.14 ± 0.05	.102 ± .002	2.59 ± 0.05
N	3.639 ± .005	92.43 ± 0.13	3.011 ± .003	76.48 ± 0.08	.111 ± .002	2.82 ± 0.05
P	4.206 ± .005	106.83 ± 0.13	3.608 ± .003	91.64 ± 0.08	.116 ± .002	2.95 ± 0.05
Q	5.795 ± .005	147.19 ± 0.13	4.682 ± .003	118.92 ± 0.08	.149 ± .002	3.78 ± 0.05

Note 1: All other dimensions identical to values found in Tables 5a & 5b

XII. Inspection and Part Replacement (Cont'd)

3. Clearance between the disc and upper ring/guide:

Measure the I.D. of the guide and the O.D. of the disc; subtract to find the cold clearance.

The maximum clearance should not be greater than the value indicated in Table 7. Greater clearances can indicate wear and can generate alignment problems and cause the valve not to reseat properly.

Table 7: Allowable Clearance Between Upper Adjusting Ring and Disc ⁽¹⁾								
Orifice	Clearance				Disc Outside Diameter		Upper Adjusting Ring (Inside Diameter)	
	min		max		in.	mm	in.	mm
	in.	mm	in.	mm				
H	.007	0.18	.014	0.36	1.905	48.39	1.919	48.74
J	.007	0.18	.014	0.36	2.445	62.10	2.459	62.46
K	.006	0.15	.013	0.33	2.930	74.42	2.939	74.65
L	.007	0.18	.014	0.36	3.638	92.41	3.652	92.76
M	.007	0.18	.014	0.36	4.079	103.61	4.093	103.96
N	.012	0.30	.019	0.48	4.483	113.87	4.502	114.35
P	.008	0.20	.017	0.43	5.448	138.38	5.465	138.81
Q	.010	0.25	.019	0.48	7.137	181.28	7.156	181.76

Note 1: Once clearance exceeds table values, further inspection is required for the disc and upper adjusting ring.

4. Adjusting rings:

If damage is present on the lower surface of the upper adjusting ring, or on the upper surfaces of the lower adjusting ring, the damaged part must be replaced. Thread damage may also be a cause for replacement, if it prevents adjustments when the valve is heated.

5. Bushing Seat:

Seat bushings are normally treated as part of the valve body and should be machined when necessary, inside the valve body. (See Seat Bushing Machining

Instructions, Section XI.B) When the "E" dimension is reduced by machining or lapping to the minimum given in Table 8b, the valve seat bushing should be remachined to the given dimension. The bushing seat can be remachined until the limiting Dimension "G" is reached as per Table 8a. See instructions concerning the "G" dimension in Table 8b.

The bushing seat must be lapped to a mirror finish to determine if they are flat and free of nicks, cuts and scratches. (See Section XI.C for Lapping Instructions.)

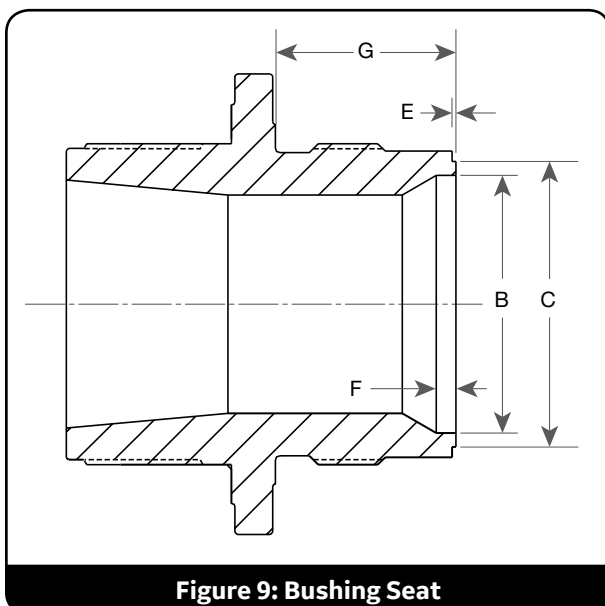

Figure 9: Bushing Seat

Table 8a: Seat Bushing Replacement Criteria		
Orifice	G min	
	in.	mm
H	.937	23.80
J	.937	23.80
K	1.187	30.15
L	1.375	34.93
M	1.375	34.93
N	1.500	38.10
P	1.750	44.45
Q	2.187	55.55

XII. Inspection and Part Replacement (Cont'd)

Table 8b: Seat Bushing Rework/Inspection Dimensions								
Orifice	B max		C		E ⁽¹⁾		F	
	in.	mm	in.	mm	in.	mm	in.	mm
H	1.182	30.02	1.304 ^{+0.000} - .003	33.12 ^{+0.00} - 0.08	.028 ^{+0.002} - .003	0.71 ^{+0.05} - 0.08	.079 ^{+0.002} - .003	2.01 ^{+0.05} - 0.08
J	1.513	38.43	1.635 ^{+0.000} - .003	41.53 ^{+0.00} - 0.08	.025 ^{+0.005} - .000	0.64 ^{+0.13} - 0.00	.098 ^{+0.005} - .000	2.49 ^{+0.13} - 0.00
K	1.809	45.95	1.931 ^{+0.000} - .003	49.05 ^{+0.00} - 0.08	.025 ^{+0.005} - .000	0.64 ^{+0.13} - 0.00	.117 ^{+0.005} - .000	2.97 ^{+0.13} - 0.00
L	2.248	57.10	2.400 ^{+0.000} - .003	60.96 ^{+0.00} - 0.08	.028 ^{+0.002} - .003	0.71 ^{+0.05} - 0.08	.149 ^{+0.002} - .003	3.78 ^{+0.05} - 0.08
M	2.523	64.08	2.676 ^{+0.000} - .003	67.97 ^{+0.00} - 0.08	.028 ^{+0.002} - .003	0.71 ^{+0.05} - 0.08	.167 ^{+0.002} - .003	4.24 ^{+0.05} - 0.08
N	2.773	70.43	2.950 ^{+0.006} - .000	74.93 ^{+0.15} - 0.00	.025 ^{+0.005} - .000	0.64 ^{+0.13} - 0.00	.179 ^{+0.005} - .000	4.55 ^{+0.13} - 0.00
P	3.364	85.45	3.547 ^{+0.000} - .004	90.09 ^{+0.00} - 0.10	.036 ^{+0.005} - .000	0.91 ^{+0.13} - 0.00	.217 ^{+0.005} - .000	5.51 ^{+0.13} - 0.00
Q	4.424	112.37	4.615 ^{+0.000} - .003	117.22 ^{+0.00} - 0.08	.036 ^{+0.005} - .000	0.91 ^{+0.13} - 0.00	.285 ^{+0.005} - .000	7.24 ^{+0.13} - 0.00

Note 1: When (E) dimension is reduced to .020" (0.51 mm) for H – N orifices, or .025" (0.64mm) for P – Q orifices, restore the dimensions to those indicated in Table 8b. Seat Bushing is re-machinable until minimum (G) dimension is reached, then must be discard.

XIII. Reassembly

During reassembly, three items are of extreme importance. They are:

- 1) Alignment
- 2) Cleanliness
- 3) Lubrication

To achieve the correct alignment, the bearing surfaces of the compression screw/upper spring washer, spindle/lower spring washer and spindle to disc pocket should each be ground together to attain a perfect match. This is done by applying a lapping and grinding compound of about 500 grit on one of the surfaces and rubbing the surfaces together until a smooth unbroken contact point is established on both surfaces.

All bearing surfaces and threaded areas must be lubricated using a high quality high temperature lubricant. At the factory, Nickel-Ease[®] is used and is recommended. For environments where corrosion is a problem, contact the factory field service department for suggestions on special coating or plating procedures which will protect the parts.

1. Thread the lower ring onto the seat bushing and turn it down until it is below the seating surface. (This allows the disc to rest on the bushing without interference from the ring).
2. Thread the upper ring/guide into the valve body reestablishing its original relationship to the bushing, as measured in Section X, Disassembly of 1511 Series Safety Valve, step 2. Insert the upper adjusting ring pin into the valve and tighten. The ring should now be able to rock back and forth but not turn. If position is not known, refer to Section XIV.C.
3. After inspecting both the disc and bushing seat for cleanliness, thread the spindle into the disc and insert the disc gently into the valve until it rests on the bushing.
4. Place the spring and spring washers onto the spindle.
5. Place the yoke over the spindle and replace the cap screws or nuts. Care must be taken to tighten the yoke down evenly to prevent distortion and misalignment.

XIII. Reassembly (Cont'd)

6. Thread the compression screw into the yoke, reestablish the original relationship between compression screw and spindle, as measured in Section X, Disassembly of 1511 Series Safety Valve, Step 6. Then tighten the compression screw lock nut.
7. Raise the lower ring until it contacts the disc then lower it the number of notches needed to reestablish its original relationship to the disc, as measured in Section X, Disassembly of 1511 Series Safety Valve, step 2. Thread the lower adjusting ring pin into the body and tighten. The ring should be free to rock back and forth but not turn. If position is not known, refer to Section XIV.C.
8. Thread the release nut onto the spindle and replace the cap, lever and lever pin. Adjust the release nut so there is from .125" (3.18 mm) to .063" (1.59 mm) clearance between the release nut and lever. Remove the lever pin, lever and cap, replace the lock nut or cotter pin, and tighten it against the release nut. Replace the cap, lever, lever pin and cotter pin and tighten the set screw. The valve is now ready for setting and testing.

XIV. Setting and Testing

A. Steam Testing Procedures

1. Remove the caps on all valves to be set on the steam drum and main steam line, or other pressure vessel.
2. Install a "verified calibrated" pressure gauge on the drum near the valves being set. When the main steam line valves are to be set, install the calibrated gauge to read line pressure upstream of the valves to be tested.
3. After the pressure in the boiler has increased to 80 percent of the operating pressure, install gags on all valves except the high set valve. Gags should be installed hand tight (no wrenches or mechanical force).
4. Examine the nameplate on the high set valve. The symbol that is present on the nameplate will indicate the proper standard of operation, as described in Table 9.

During reassembly, the adjusting rings and compression screw should be reset as they were prior to disassembly. (If the correct adjusting rings positions are not known, the adjusting rings should be preset according to instructions in Section XIV.C) Before attempting to make ring adjustments on a valve under pressure, gag the valve.
5. When presetting is complete, remove the gag and replace the cap and lifting lever assembly. Attach a rope to the lever and stand by to hold the valve open if necessary. Now the valve is ready to test.
6. Increase the boiler pressure at a rate not to exceed 2 psig (0.14 barg) per second. Note and record the pressure indicated on the pressure gauge when the valve pops open. After the valve pops open, reduce the fire in the boiler and lower the pressure until the valve closes. Note and record the pressure when the valve closes.
7. Determine if the valve popping point and reseating point comply with the ASME requirements.
 - a. If the valve operation meets the appropriate standard, raise the pressure in the boiler and conduct two more verification tests.
 - b. If in raising the boiler pressure, the valve does not pop open within 3 percent overpressure (for ASME Section I valves), or 10 percent overpressure (for ASME Section VIII valves), reduce the fire in the boiler and pull the rope to open the valve. Release the rope and allow the valve to close when the boiler pressure returns to operating level. Allow the boiler to reduce to approximately 85 percent of the set pressure. Remove the cap and lifting lever assembly from the valve, and turn the compression screw lock nut counter-clockwise (as viewed from the top of the valve) until it moves freely. Reduce the compression in the spring by turning the adjusting screw counter clockwise one turn (as viewed from the top of the valve). Replace the cap and lifting lever and retest the valve. Continue repeating this procedure until the valve opens at, or below, the set pressure recorded on the nameplate.
 - c. If the valve opens at a pressure below the recorded set pressure, allow the valve to close and the boiler

XIV. Setting and Testing (Cont'd)

pressure to reduce to 85 percent of set pressure. Increase the compression on the spring by turning the compression screw clockwise 1/6th of a turn. Tighten the adjusting screw lock nut and replace the cap and lifting lever assembly. Retest the valve as described in Step 6. If the valve continues to open below the required set pressure, calculate how many turns to move the adjusting screw to cause the valve to open at the correct set pressure. Adjust as necessary.

- d. If the valve opens and closes rapidly, (called “chattering”) hold the valve open to prevent damage to the valve. Reduce the fire in the boiler and allow the boiler pressure to reduce to approximately 85 percent of the set pressure. Gag the valve, and reset the adjusting rings according to presetting instructions, (see Section XIV.C).
- e. If the valve indicates simmer at a pressure greater than 1 percent of the set pressure of the valve, allow the valve to reseal and the boiler pressure to reduce to 85 percent of set pressure. Gag the valve to

prevent accidental lifting while making adjustments. Remove the lower adjusting ring pin and raise the lower adjusting ring. As viewed through the ring pin hole, move the adjusting ring from left to right one or two notches. Remove the gag, retest and note when simmer occurs and repeat as necessary.

Note: The lower adjusting ring should be adjusted to the notch that provides a minimum of simmer and does not interfere with the blowdown of the valve.

- f. If the valve “pops” open then drops out of lift, like it was going to close, but remains open at a very low lift, this is called a “hang up” and indicates that the position of the lower adjusting ring is interfering with the blowdown of the valve. To correct a hang up, gag the valve, remove the lower ring pin and lower the adjusting ring one notch (as viewed through the ring pin hole, move the adjusting ring from the right to the left to lower the adjusting ring). Remove the gag, retest and note the reseating pressure of the valve it should close sharply at a higher pressure.

Table 9

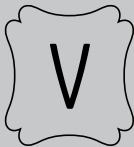
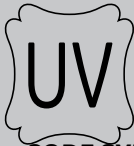
Table 9		
<p>ASME Boiler and Pressure Vessel Code Section and Symbol</p> <div style="text-align: center; margin: 20px 0;">  </div> <p>CODE SYMBOL STAMP ASME Section I</p>	<p>Set Pressure Tolerance (The valve must “POP” open within the range indicated below.)</p> <p>If valve set pressure is less than or equal to 70 psig (4.83 barg): ±2 psig (±0.14 barg)</p> <p>If valve set pressure is 71 psig (4.9 barg) up to and including 300 psig (20.68 barg): ±3 percent of set pressure</p> <p>If valve set pressure is 301 psig (20.75 barg) up to and including 1000 psig (68.95 barg): ±10 psig (±0.69 barg)</p> <p>If valve set pressure is 1001 psig (69.02 barg) or greater ±1 percent of set pressure</p>	<p>Blowdown Requirements</p> <p>After opening, the valve must reclose within a range of 98 percent to 96 percent, however, if the valve set pressure is 100 psig (6.9 barg) or less the valve must reclose within a range of 2 to 4 psig (0.14 to 0.28 barg) below set pressure.</p>
<div style="text-align: center; margin: 20px 0;">  </div> <p>CODE SYMBOL STAMP ASME Section VIII</p>	<p>If valve set pressure is less than or equal to 70 psig (4.83 barg): ±2 psig (±0.14 barg)</p> <p>If valve set pressure is 71 psig (4.9 barg) or greater ±3 percent of set pressure</p>	<p>After opening the valve must reclose before the system pressure returns to normal operating pressure.</p>

BHGE RECOMMENDS THAT THE MAXIMUM OPERATING PRESSURE NEVER EXCEEDS 94 PERCENT OF THE SET PRESSURE OF 1511 SERIES SAFETY VALVE.

XIV. Setting and Testing (Cont'd)

- g. If the valve closes sharply but the reseating pressure is too low in comparison to the standard in Table 10, blowdown is excessive. Gag the valve, remove the upper ring pin, raise the upper adjusting ring 10 notches, replace the ring pin, remove the gag and retest the valve. If the reseating pressure has not risen enough to meet the blowdown standard, repeat the procedure until the blowdown standard is achieved.

Note: It may be possible that in raising the upper adjusting ring to reduce the blowdown, the valve may develop a hang up, correct it as described in Step f. above, and then continue if necessary to reduce the blowdown.

- h. If the blowdown is less than the standard required, the reseating pressure can be lowered by gagging

the valve, removing the upper ring pin and lowering the upper adjusting ring 10 notches (as viewed through the ring pin hole, move the adjusting ring from the right to the left.) Remove the gag, replace the adjusting ring pin and retest the valve. If the reseating pressure is not reduced enough to meet the standard, repeat this procedure until the standard is achieved. The upper adjusting ring should be positioned to provide no more blowdown than that indicated in Table 9.

8. Once the valve has tested in compliance with the appropriate standard, conduct two more verification tests. All external adjustments should be sealed after completing final setting.
9. Proceed to the next valve to be tested.

B. Hydrostatic Testing & Gagging

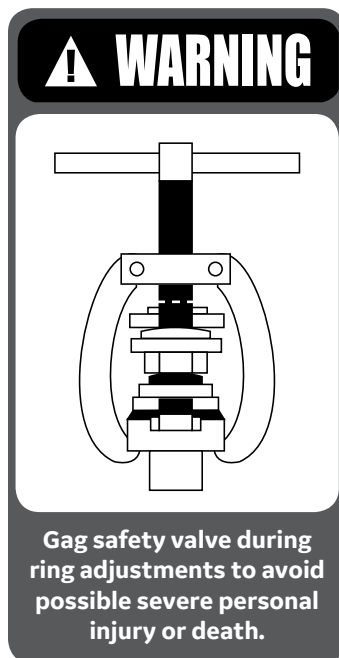

B.1 General Information

During any hydrostatic test all safety valves on the unit must be gagged. This gagging procedure prevents the possibility of damage to the safety valve internals in the event that the test pressure exceeds the safety valve set pressure.

When hydrostatic pressure will exceed the set pressure of the safety valve, it is recommended the valve be replaced with a blind flange during hydrostatic testing.

Probably the most common source of safety valve trouble is overgagging. During hydrostatic testing, and during safety valve setting, gags should be applied only hand tight. During setting, overgagging could cause damage to the seating surface and result in leakage. In applying gags, remember that the valve spring will hold the valve closed against its set pressure. The additional gag load applied should be only enough to ensure that the valves do not lift at the expected over-pressure.

Gags should never be applied when the boiler is cold. The spindle of the safety valve expands considerably with the temperature increase as pressure is raised. If it is not free to expand with this temperature change, the spindle may be damaged.

Boiler pressure should be increased to 80 percent of the pressure of the low set valve before applying the gags.

Hand tighten the gags of drum and superheater valves with only a light force.

XIV. Setting and Testing (Cont'd)

B.2 Application of Test Gags (All Pressures)

1. Refer to Figures 1 & 2 on Section VIII. Remove lever pin and lever. Then loosen cap screw and remove cap.
2. Center the test gag screw in the exposed end of the spindle and hook the legs of gag under the sides of the yoke as shown in Figure 10.

Do not apply the gag load until the boiler hydrostatic pressure is equal to 80 percent of the pressure to which the low set valve is adjusted.

3. Apply the gag load by turning the gag screw clockwise. If the gag on any valve has not been tightened sufficiently, the valve will leak.

If this occurs, the hydrostatic test pressure should be reduced until the valve becomes tight and then the gag should be tightened still further.

This procedure must be followed exactly since it is very difficult to stop the leak by additional gagging once it has started. Any attempt to pinch off the leakage through the valve without first lowering the hydrostatic pressure may result in damage to the valve seats.

4. After the hydrostatic test is completed, the gags should be removed when the hydrostatic pressure has been reduced to 85 percent to 90 percent of the low set valve.

Under no circumstances should the gags be left on valves with no hydrostatic pressure on the system.

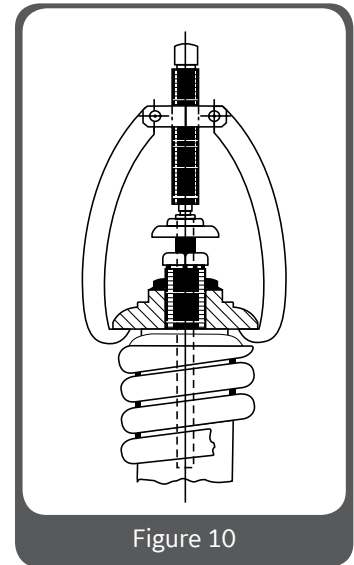

Figure 10

C. Presetting the Adjusting Rings

If the correct position of the adjusting rings (as measured in the disassembly procedure (see Section X) is not known, the valve adjusting rings may be positioned using the information in Table 10.

The lower ring may be positioned by turning the lower adjusting ring up until it contacts the disc. After choosing the appropriate orifice size, turn the adjusting ring down the corresponding number of notches listed in the "Lower Ring" column. Then, replace the adjusting ring pin. The adjusting ring must be free to move both directions, but not rotate.

The upper ring may be positioned by turning the upper adjusting ring down towards the nozzle bushing, until it becomes level with the bottom of disk. Then after choosing the appropriate orifice size, turn the adjusting ring down the

corresponding number of turns (360°), listed in the "Upper Ring" column. Then replace the adjusting ring pin. The adjusting ring must be free to move both directions, but not rotate.

The adjusting rings are now in a starting position for full lift steam testing. These adjusting ring settings will generally provide a blowdown greater than required by Section I of the ASME Code, and should be adjusted for the particular application.

XIV. Setting and Testing (Cont'd)

Adjusting Ring Settings

Note: It is important to note that all adjustments of adjusting rings are BHGE initial adjustments only, and are not intended to be final adjustments. This final adjustment must be made on the operating system with conditions approximating those that will be realized under actual operating conditions.

Orifice	Upper Ring No. of Notches	Lower Ring No. of Notches	Upper Ring Position From Being Level with Bottom of the Disc	Lower Ring Position From Seat Level
H	30	24	Down Two Turns	Down 2 to 6 Notches
J	36	30	Down Two Turns	Down 2 to 7 Notches
K	45	32	Down Two Turns	Down 2 to 5 Notches
L	54	40	Down Two Turns	Down 3 to 13 Notches
M	45	36	Down Two Turns	Down 4 to 8 Notches
N	50	40	Down Two Turns	Down 5 to 12 Notches
P	50	42	Down Two Turns	Down 9 to 13 Notches
Q	60	48	Down Two Turns	Down 9 to 15 Notches

D. Electronic Valve Testing (EVT*)

Periodic tests may be required for verification of valve set pressure. The Consolidated EVT provides for this capability. However, set pressure is the only factor which can be verified. Valves should be initially set using full system pressure (as outlined in Section XIV.A). The EVT may be used for subsequent checks of set pressure.

Accuracy of results obtained by the use of this device depends on several factors. First, friction must be reduced as a source of error so that, for a given pressure, the EVT repeatedly produces exactly the same lifting force. Second,

gauge calibration and vibration, and the effective seating area between valves of the same size and type, will also affect accuracy. With well calibrated gauges and valve seats in good condition, accuracy on the order of 1 percent of set pressure may be expected. Upon request, BHGE will provide pertinent written material concerning the EVT. This material specifies all required information necessary to ensure proper usage of this device.

XV. Trouble Shooting the 1511 Series Safety Valve

Problem	Possible Cause	Corrective Action
Valve does not go into full lift	<ul style="list-style-type: none"> A. Upper ring positioned too high B. Foreign material trapped between disc holder & guide 	<ul style="list-style-type: none"> A. Lower upper adjusting ring B. Disassemble valve and correct any abnormality. Inspect system for cleanliness.
Failure to open at set pressure Simmer	<ul style="list-style-type: none"> A. Improper compression screw adjustment B. Lower ring positioned too low. C. Steam line vibrations 	<ul style="list-style-type: none"> A. Adjust set pressure B. Raise lower adjusting ring C. Investigate and correct cause
Valve Leaking and/or exhibits erratic popping actions	<ul style="list-style-type: none"> A. Damaged seat B. Part misalignment C. Operating too close to set pressure D. Discharge stack binding on valve outlet 	<ul style="list-style-type: none"> A. Disassemble valve, lap seating surfaces, replace disc if required. B. Disassemble valve, inspect contact area of disc and seat bushing, lower spring washer or spindle, compression screw, spindle straightness, etc. C. Lower operating pressure. D. Correct source of binding
Hang-up, or valve does not close completely	<ul style="list-style-type: none"> A. Lower ring positioned too high B. Foreign material C. Improper disc/guide clearance 	<ul style="list-style-type: none"> A. Move lower ring to the left one notch per adjustment and test. Repeat until problem is eliminated. B. Disassemble valve and correct any abnormal condition. Inspect system for cleanliness. C. Verify proper clearance
Excessive blowdown	<ul style="list-style-type: none"> A. Upper ring positioned too low. B. Built up back pressure excessive 	<ul style="list-style-type: none"> A. Raise upper adjusting ring B. Decrease exhaust pressure by increasing discharge stack area.
Chatter or short blowdown	<ul style="list-style-type: none"> A. Upper ring positioned too high B. Excessive inlet piping pressure drop C. Valve size improper for application 	<ul style="list-style-type: none"> A. Lower upper adjusting ring B. Reduce inlet pressure drop to less than one-half of required valve blowdown by redesigning inlet piping. C. Verify valve sizing

XVI. Maintenance Tools and Supplies

Table 11: Maintenance Tools and Supplies					
Ring Laps					
Valve Orifice	Part No.	Valve Orifice	Part No.		
F	1672805	M	1672810		
G	1672805	N	1672811		
H	1672806	P	1672811		
J	1672807	Q	1672812		
K	1672808				
L	1672809				

Lapping Compounds					
Brand	Grade	Grit	Lapping Function	Size Container	Part No.
1. Clover	1A	320	General	4 oz.	1993
2. Clover	3A	500	Finishing	4 oz.	1994
3. Kwik-AK	--	1000	Polishing	1 lb.	19911
- Shun				2 oz.	19912

Lubricants			
Brand	Application Points	Size Container	Part No.
Nickel Ease	All threaded connections Spindle Tip-Ball End Spindle-Washer Bearing Radius Compression Screw-Bearing End	2 oz.	VA437

XVII. Replacement Parts Planning

A. Basic Guidelines

The basic objectives in formulating a replacement parts plan are:

- PROMPT AVAILABILITY
- MINIMUM DOWNTIME
- SENSIBLE COST
- SOURCE CONTROL

Guidelines for establishing meaningful inventory levels:

Parts Classification		
PART CLASSIFICATION	REPLACEMENT FREQUENCY	PREDICTED AVAILABILITY
CLASS I	MOST FREQUENT	70 percent
CLASS II	LESS FREQUENT BUT CRITICAL	85 percent
CLASS III	SELDOM REPLACED	95 percent
CLASS IV	HARDWARE	99 percent
CLASS V	PRACTICALLY NEVER REPLACED	100 percent

Consult the Recommended Spare Parts list (see Section XIX) to define the parts to be included in the inventory plan.

Select parts and specify quantities.

XVII. Replacement Parts Planning (Cont'd)

B. Identification and Ordering Essentials

Identification and Ordering Essentials

When ordering service parts, please furnish the following information to ensure receiving the correct replacement parts:

Identify valve by the following nameplate data:

1. Size
2. Type
3. Temperature Class
4. Serial Number

Example: 1 1/2" 1511H-0-2-20

BY-23098

Specify parts required by:

1. Part Name (See illustration at front of manual).
2. Part Number (if known)
3. Quantity

Contact your local Green Tag Center.

In addition, the serial number is stamped on the top edge of the outlet flange. Be sure to include the one or two letters preceding the figures in the serial number. A typical valve nameplate is shown in Figure 11.

		CONSOLIDATED				NB
		CERTIFIED BY		<small>ALEXANDRIA, LOUISIANA U.S.A.</small>		
TYPE		1511H-0-2-20				
	SIZE	1 1/2	SERIAL NO.	BY-23098		
	SET PRESS.	600	PSI	LIFT	.320	IN.
CAP.		36763	LBS/HR. AT		SAT.	•F
B/M		9403401		DATE		7-10

Figure 11: Valve Nameplate

XVIII. Consolidated Genuine Parts

The next time replacement parts are needed, keep these points in mind:

- BHGE designed the parts
- BHGE guarantees the parts
- The Consolidated valve products have been in use since 1879
- BHGE offers worldwide service
- BHGE has fast response availability for parts

XIX. Recommended Spare Parts

Table 12: Recommended Spare Parts

Class	Part No. <small>(1)</small>	Part Name	Ratio Parts/ Valves (Minimum)	Ratio Parts/ Valves (Maximum)	Predicted Availability
I	3	Disc	1/3	1/1	70 percent
	5	Adj. Ring Pin (Lower)	1/3	1/1	
	7	Adj. Ring Pin (Upper)	1/3	1/1	
II	4	Adj. Ring (Lower)	1/5	1/3	85 percent
	6	Adj. Ring (Upper)	1/5	1/3	
	10	Spindle	1/5	1/3	
III	2	Seat Bushing	1/5	1/3	95 percent
	11	Spring Washers (2)	1 Set/5	1 Set/3	
	12	Spring	1/5	1/3	
	13	Compression Screw	1/5	1/3	
IV	9	Yoke Cap Screws	1/5	1/3	99 percent
	14	Compression Screw Nut	1/5	1/3	
	15	Cap	1/5	1/3	
	16	Cap Set Screw	1/5	1/3	
	17	Lever	1/5	1/3	
	18	Release Nut	1/5	1/3	
	19	Lever Pin	1/5	1/3	
	20	Spring Cover	1/5	1/3	
	21	Cover Bolt	1/5	1/3	
	22	Cover Nut	1/5	1/3	
	23-26	Cap & Lifting Lever Assembly	1/5	1/3	
	27	Floating Washer	1/5	1/3	
	28	Lift Stop	1/5	1/3	
29	Spindle Locknut	1/5	1/3		

Note 1: Refer to Figure 1 for the part numbers and their corresponding parts.

DESIGN CODE KEY:

FSD - Flat Solid Design is designated by a "-20" in the valve code on the nameplate (example: 1 1/2" 1511H-0-2-20).

XX. Manufacturer's Field Service & Repair Program

A. Field Service

BHGE maintains one of the largest and most competent network of field service technicians in the industry. Service technicians are located at strategic points throughout the United States to respond to customer's requirements for service, even in the event of extreme off-hour emergency situations. Each service technician is trained and experienced in servicing Consolidated products.

It is highly recommended that the professional expertise of a field service technician be employed to make final field adjustments during the initial setting of all Consolidated valves.

For further information, please contact your local Green Tag Center.

B. Repair Facilities

BHGE's Consolidated repair department, in conjunction with the manufacturing facilities, are equipped to perform specialized repairs and product modifications, e.g. bushing replacements, hydroset calibrations, electromatic relief valve repairs, code welding, pilot replacement, etc.

For further information, please contact your local Green Tag Center.

C. Maintenance Training

Rising costs of maintenance and repair in the utility and process industries indicate the need for trained maintenance personnel. BHGE conducts service seminars that can help your maintenance and engineering personnel to reduce these costs.

Seminars, conducted either at your site, or at BHGE's Consolidated training facility, provide participants with an introduction to the basics of preventative maintenance. These seminars help to reduce downtime, reduce unplanned repairs, and increase valve safety. While they do not make "instant" experts, they do provide the participants with "Hands On" experience with Consolidated valves. The seminar also includes valve terminology and nomenclature, component inspection, troubleshooting, setting and testing, with emphasis on the ASME Boiler and Pressure Vessel Code.

For further information, please contact your local Green Tag Center.

DIRECT SALES OFFICE LOCATIONS

AUSTRALIA

Brisbane:
Phone: +61-7-3001-4319
Fax: +61-7-3001-4399

Perth:
Phone: +61-8-6595-7018
Fax: +61-8-6595-7299

Melbourne:
Phone: +61-3-8807-6002
Fax: +61-3-8807-6577

BELGIUM

Phone: +32-2-344-0970
Fax: +32-2-344-1123

BRAZIL

Phone: +55-19-2104-6900

CHINA

Phone: +86-10-5738-8888
Fax: +86-10-5918-9707

FRANCE

Courbevoie
Phone: +33-1-4904-9000
Fax: +33-1-4904-9010

GERMANY

Ratingen
Phone: +49-2102-108-0
Fax: +49-2102-108-111

INDIA

Mumbai
Phone: +91-22-8354790
Fax: +91-22-8354791

New Delhi

Phone: +91-11-2-6164175
Fax: +91-11-5-1659635

ITALY

Phone: +39-081-7892-111
Fax: +39-081-7892-208

JAPAN

Tokyo
Phone: +81-03-6871-9008
Fax: +81-03-6890-4620

KOREA

Phone: +82-2-2274-0748
Fax: +82-2-2274-0794

MALAYSIA

Phone: +60-3-2161-0322
Fax: +60-3-2163-6312

MEXICO

Phone: +52-55-3640-5060

THE NETHERLANDS

Phone: +31-15-3808666

RUSSIA

Veliky Novgorod
Phone: +7-8162-55-7898
Fax: +7-8162-55-7921

Moscow

Phone: +7 495-585-1276
Fax: +7 495-585-1279

SAUDI ARABIA

Phone: +966-3-341-0278
Fax: +966-3-341-7624

SINGAPORE

Phone: +65-6861-6100
Fax: +65-6861-7172

SOUTH AFRICA

Phone: +27-11-452-1550
Fax: +27-11-452-6542

SOUTH & CENTRAL

AMERICA AND THE CARIBBEAN

Phone: +55-12-2134-1201
Fax: +55-12-2134-1238

SPAIN

Phone: +34-93-652-6430
Fax: +34-93-652-6444

UNITED ARAB EMIRATES

Phone: +971-4-8991-777
Fax: +971-4-8991-778

UNITED KINGDOM

Bracknell
Phone: +44-1344-460-500
Fax: +44-1344-460-537

Skelmersdale

Phone: +44-1695-526-00
Fax: +44-1695-526-01

UNITED STATES

Jacksonville, Florida
Phone: +1-904-570-3409

Deer Park, Texas

Phone: +1-281-884-1000
Fax: +1-281-884-1010

Houston, Texas

Phone: +1-281-671-1640
Fax: +1-281-671-1735

bhge.com

*Denotes a trademark of Baker Hughes, a GE company, LLC.

Other company names and product names used in this document are the registered trademarks or trademarks of their respective owners.

© 2018 Baker Hughes, a GE company LLC - All rights reserved.

Baker Hughes, a GE company, LLC and its affiliates ("BHGE") provides this information on an "as is" basis for general information purposes and believes it to be accurate as of the date of publication. BHGE does not make any representation as to the accuracy or completeness of the information and makes no warranties of any kind, specific, implied or oral, to the fullest extent permissible by law, including those of merchantability and fitness for a particular purpose or use. BHGE hereby disclaims any and all liability for any direct, indirect, consequential or special damages, claims for lost profits, or third party claims arising from the use of the information, whether a claim is asserted in contract, tort, or otherwise. The BHGE logo is a trademark of Baker Hughes, a GE company LLC. GE and the GE monogram are trademarks of the General Electric Company used under trademark license.

GEA19558C 09/2018

**BAKER
HUGHES**
a GE company

